

YAMAHA

GENERAL
MIDI
INSTRUMENT

TONE GENERATOR

TG100

GETTING STARTED MANUAL

1 Safety, Warnings & Notes

Please read the following information before operating your TG100.

Safety information

- **Make sure** the TG100 power supply adaptor's power cord is not located in a position where it is likely to be walked on and/or pinched by other equipment placed near to it.
- **Do not** expose the TG100 to extremes of humidity.
- **Do not** place the TG100 near water.
- **Do not** place the TG100 in areas subject to extremely low temperatures.
- **Do not** place the TG100 in locations subject to excessive dust.
- **Do not** place the TG100 in an area subject to vibration.
- **Do not** expose the TG100 to severe shocks.
- **Do not** place the TG100 in direct sunlight, close to heating units or in areas subject to high temperatures.
- The ambient temperature where the TG100 is located should be between 10°-35°C.

Warnings

- Use **only** the power supply adaptor supplied with the TG100.
- The TG100 power supply adaptor **should only** be connected to a power supply of the type described in this *Operating Manual* or as marked on the adaptor.
- Before connecting the adaptor to the TG100, **make sure** it is disconnected from the wall-power (mains) outlet. Always connect the adaptor to the TG100 and then plug the adaptor into the wall-power (mains) outlet.
- To reduce the risk of electric shock, **do not** remove the cover of the TG100.
- To reduce the risk of fire or electric shock, **do not** expose the TG100 to rain or moisture.
- The TG100 contains no user serviceable parts. **Refer all** servicing to qualified personnel.
- The TG100 uses digital circuits, which operate at high frequencies. When used close to TV and Radio equipment, reception may be affected. If this is the case, simply move the TG100 to a different location.
- If any of the following should occur, the TG100 should be serviced by qualified personnel:
 - The TG100 power supply adaptor's cord or plug becomes damaged in any way.
 - Metal objects or liquids get inside the TG100.
 - The TG100 is exposed to rain.
 - The TG100 is dropped and/or the enclosure is damaged.
 - The TG100 does not operate normally, or a marked change in performance is noticed.

2 Introduction

Welcome to the TG100

Thank you for purchasing the TG100. The TG100 is a 28-note polyphonic AWM (Advanced Wave Memory) tone generator. It contains 192 instrument voices and 8 drum kits. Up to 16 voices can be produced simultaneously. For details about all the TG100's features, see "TG100 features" on page 2 of the *Reference Manual*.

TG100 manuals

The TG100 has two operating manuals: This *Getting Started Manual* and a *Reference Manual*. This *Getting Started Manual* will tell you all the things you need to know to be able to use the TG100 right away. It contains four tutorial setups:

- 1) Using the TG100 with a MIDI keyboard on page 4.
- 2) Using the TG100 with a computer that has a MIDI interface on page 7.
- 3) "Using the TG100 with a computer that does not have a MIDI interface (TO HOST)" on page 9.
- 4) Editing & Saving Voices on page 11.

The *Reference Manual* contains full details about all the TG100's functions.

We recommend that you begin with this *Getting Started Manual*. This will allow you to setup your TG100, start playing the voices and familiarize yourself with some of its functions.

As you read through this manual, keep the *Reference Manual* close by, so that if you want to know more about a certain function you can refer to it. The *Reference Manual* contains an index, which will allow you to locate information quickly, and also a glossary of TG100 terminology.

Unpacking

The TG100 packaging should contain the following items:

1	TG100 TONE GENERATOR	Serial No:
1	Power Supply Adaptor (PA-1505)	
1	Getting Started Manual	
1	Reference Manual	

Store the packaging materials for future use.

Installation

The TG100 is a "half-rack-size" unit. This is one of the standard sizes for audio equipment, and means that your TG100 can easily be installed with your other audio equipment. The TG100 should be placed on a flat, stable surface, somewhere that complies with the "Safety information" on page 1.

The TG100 can be mounted into a 19" rack (flightcase size) using one of the "half-rack-size" adaptors that are available. See "Rack mounting" on page 66 of the *Reference Manual*.

3 Controls & Connections

Front panel

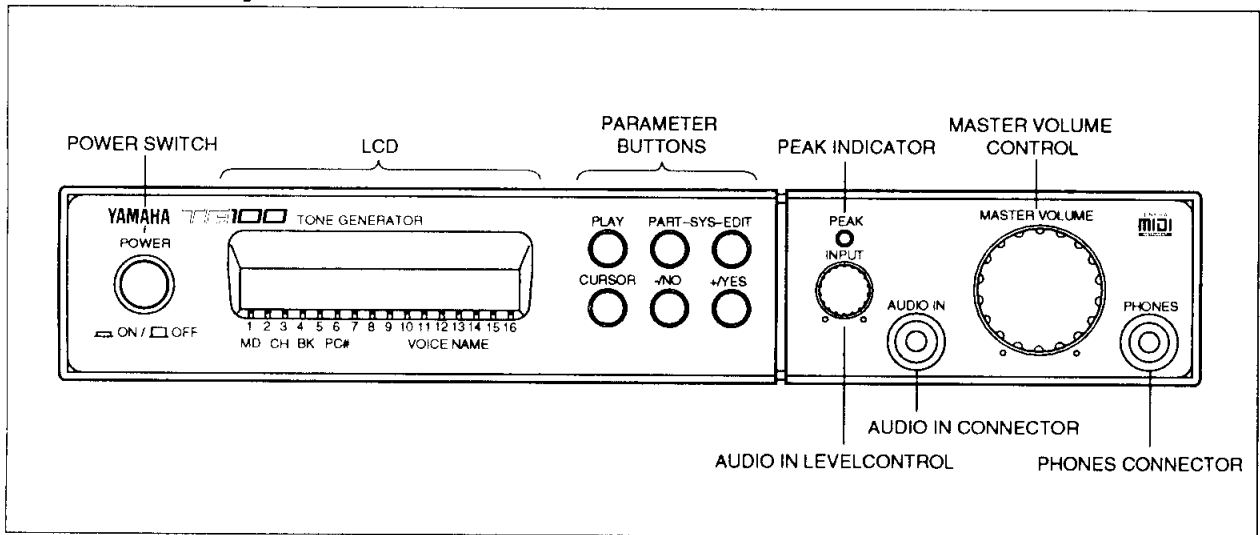

Rear panel

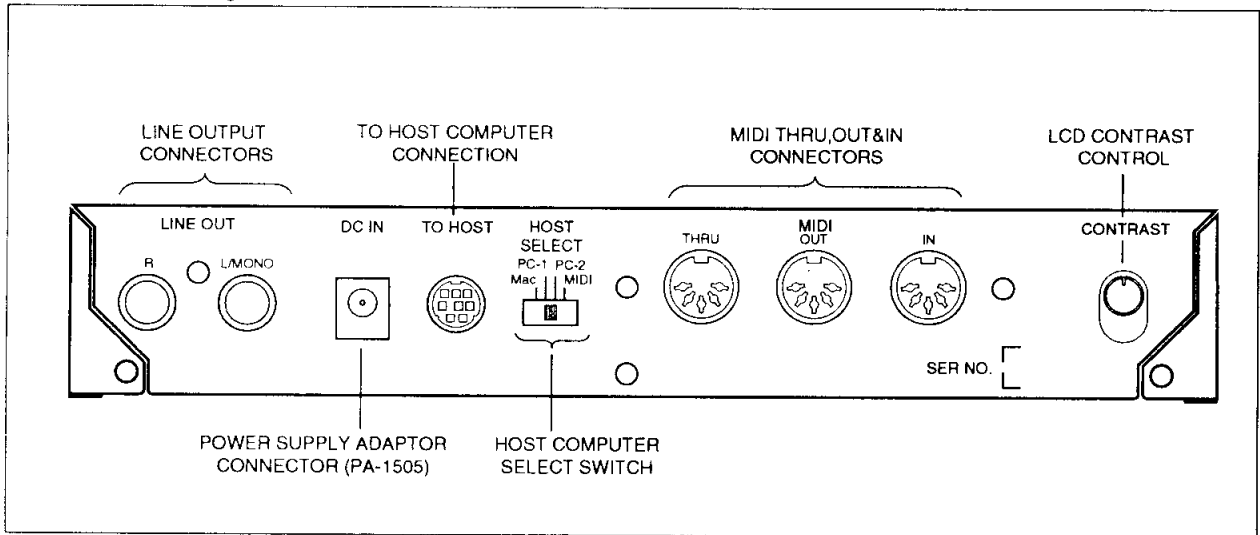

4 Using the TG100 with a MIDI keyboard

In this tutorial the TG100 is used with a MIDI keyboard. This could be a MIDI master keyboard, or a synthesizer with MIDI facilities.

What you will need

- 1) The TG100 and its power supply adaptor (PA-1505).
- 2) A MIDI master keyboard or synthesizer.
- 3) A stereo amplifier and connecting cable, or stereo headphones. If your headphones are fitted with a 1/4" (6.35mm) jack connector, you will need a stereo 3.5mm to 1/4" jack adaptor.
- 4) A MIDI connecting cable (available from your Yamaha dealer).

Making the connections

Before making any connections, make sure that all your equipment is switched off and the TG100's power supply adaptor is not plugged into the wall power outlet.

- 1) Connect the MIDI cable from your MIDI keyboard's "MIDI OUT" connector to the TG100's "MIDI IN" connector.
- 2) Connect the TG100's "LINE OUT", "R" and "L/MONO" connectors to the inputs of your amplifier (if your amplifier has only one input, connect only the TG100's "L/MONO" connector). Or, if you are using stereo headphones, connect them to the TG100's "PHONES" connector.
- 3) Connect the power supply adaptor to the TG100's "DC IN" connector.
- 4) Plug the power supply adaptor into a wall-power (mains) outlet.

Figure 1. Connecting the TG100 to a MIDI keyboard.

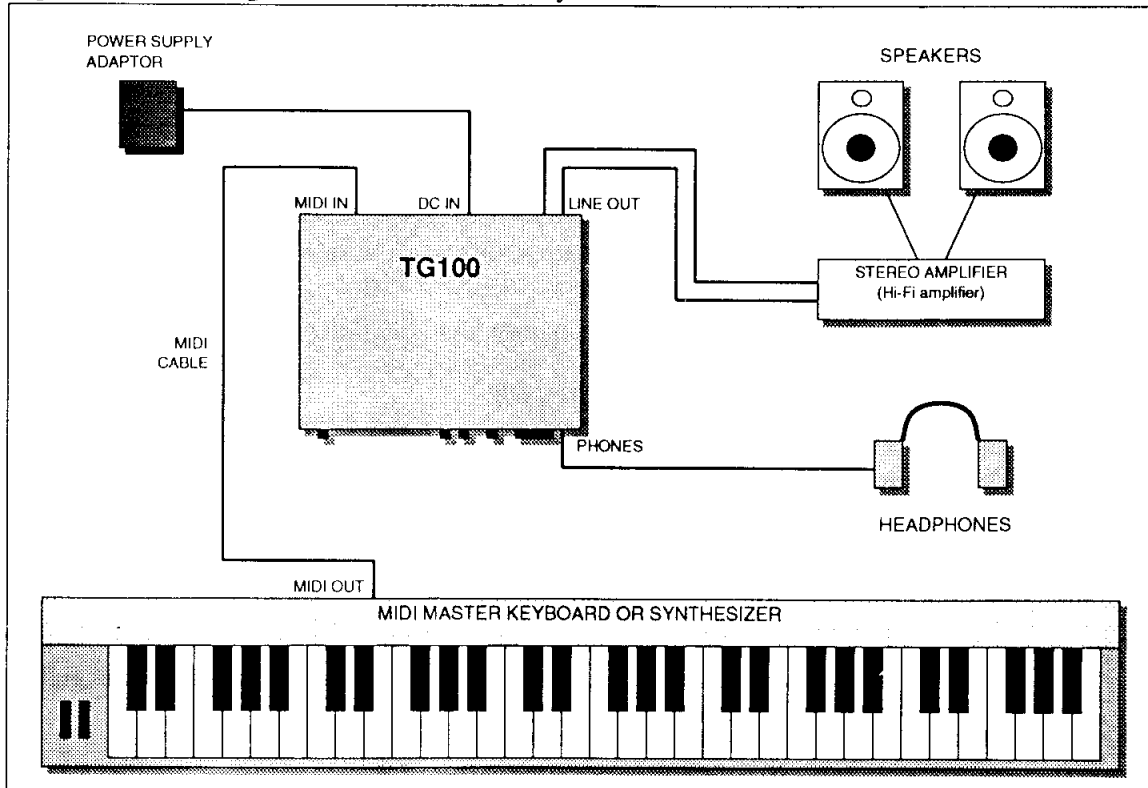

Switching on the power

- 1) Before switching on the power, set the “HOST SELECT” switch to “MIDI”.
- 2) Turn down the TG100's “MASTER VOLUME” control, then press the TG100's “POWER” switch. On the TG100's LCD, the message “YAMAHA TG100” will be shown for a few seconds, then the LCD shown below will appear.



- 3) Switch on your MIDI keyboard.
- 4) Turn down your amplifier's volume control, then switch on your amplifier.

Settings

- 1) For this tutorial, the TG100's Sound module mode must be General MIDI. If the first letter of the above LCD is not “G”, the Sound module mode must be set. See “Selecting the sound module mode” on page 16 of the *Reference Manual*.
- 2) Set the input selector on your amplifier to the input that the TG100 is connected to.
- 3) Set your MIDI keyboard so that its MIDI transmit channel is “1”.
- 4) Set your amplifier's volume control to the position used for normal listening.
- 5) Turn up the TG100's “MASTER VOLUME” control while playing your MIDI keyboard.

If everything is OK, you will be playing, and hearing voice no. 1, Acoustic Grand piano.

If you don't hear anything, check the following.

- Is all your equipment switched on.
- Is your MIDI keyboard set to the correct MIDI channel.
- Check the audio, and MIDI connections.
- Is the TG100's “HOST SELECT” switch set to MIDI.
- Make sure the TG100's MASTER VOLUME control is turned up.
- Check the settings on your amplifier: input selector, volume, speakers, headphones, etc.
- See “Troubleshooting” on page 63 of the *Reference Manual*.

Selecting instrument voices

The TG100 has 192 preset instrument voices arranged into three voice banks.

- G** - General MIDI
- D** - DISK ORCHESTRA
- C** - C/M

There is also an Internal voice bank, which contains the 64 voices that can be edited.

See “Voice bank table” on page 19 of the *Reference Manual*, or the “pullout” voice table card for a listing of all the TG100's voices.

Selecting a voice bank

- 1) Repeatedly press the [CURSOR] button until the LCD cursor is positioned as shown below.

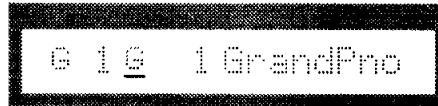

- 2) Use the [+1/YES] and [-1/NO] buttons to select a voice bank.

Selecting an instrument voice

- 1) Repeatedly press the [CURSOR] button until the LCD cursor is positioned under the "1", as shown below.

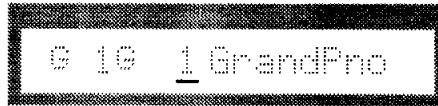

- 2) Use the [+1/YES] and [-1/NO] buttons to select an instrument voice.

Playing the drum kits

- 1) To play the TG100's drums kits you must change your MIDI keyboard's MIDI transmit channel to "10".

Each drum sound is assigned to a note on your MIDI keyboard. Drum sounds are arranged into 8 drum kits:

PC# No.	KIT NAME
1	Standard
9	Room
17	Power
25	Electronic
26	Analog
33	Jazz (same as the Standard kit)
41	Brush
49	Orchestra
126	Clavinov (Clavinova)
127	RX
128	C/M

See the drum kit layouts on page 25 to page 28 of the *Reference Manual*, or the "pullout" voice table card for a listing of all the TG100's drums sounds.

Selecting drum kits

- 1) Repeatedly press the [CURSOR] button until the LCD cursor is at the CH position.
- 2) Repeatedly press the [+1/YES] button until the following display is shown.

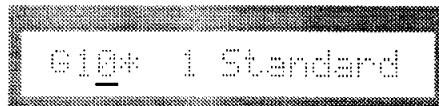

- 3) Press the [CURSOR] button once to position the LCD cursor at the PC# position.
- 4) Use the [+1/YES] and [-1/NO] buttons to select a drum kit.

5 Using the TG100 with a computer that has a MIDI interface

In this tutorial the TG100 is used with a computer that has a MIDI interface.

If you are not sure how to connect your computer, please consult your Yamaha dealer.

What you will need

- 1) The TG100 and its power supply adaptor (PA-1505).
- 2) A MIDI master keyboard or synthesizer.
- 3) A computer with a MIDI interface.
- 4) MIDI sequencing software.
- 5) A stereo amplifier and connecting cable, or stereo headphones. If your headphones are fitted with a 1/4" (6.35mm) jack connector, you will need a stereo 3.5mm to 1/4" jack adaptor.
- 6) Two MIDI connecting cables.

Making the connections

Before making any connections, make sure that all your equipment is switched off and the TG100's power supply adaptor is not plugged into the wall-power (mains) outlet.

- 1) Connect a MIDI cable from your MIDI keyboard's "MIDI OUT" connector to your computer's "MIDI IN" connector.
- 2) Connect a MIDI cable from your MIDI computer's "MIDI OUT" connector to the TG100's "MIDI IN" connector.
- 3) Connect the TG100's "LINE OUT", "R" and "L/MONO" connectors to the inputs of your amplifier (if your amplifier has only one input, connect only the TG100's "L/MONO" connector). Or, if you are using stereo headphones, connect them to the TG100's "PHONES" connector.
- 4) Connect the power supply adaptor to the TG100's "DC IN" connector.
- 5) Plug the power supply adaptor into a wall-power (mains) outlet.

Switching on the power

- 1) Before switching on the power, set the "HOST SELECT" switch to "MIDI".
- 2) Turn down the TG100's "MASTER VOLUME" control, then press the TG100's "POWER" switch. On the TG100's LCD, the message "YAMAHA TG100" will be shown for a few seconds, then the LCD shown below will appear.

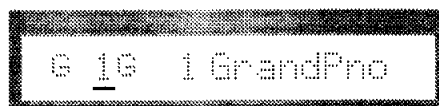

- 3) Switch on your MIDI keyboard.
- 4) Switch on your computer and load your MIDI sequencing software.
- 5) Turn down your amplifiers volume control, then switch on your amplifier.

Figure 2. Connecting to a computer that has a MIDI interface.

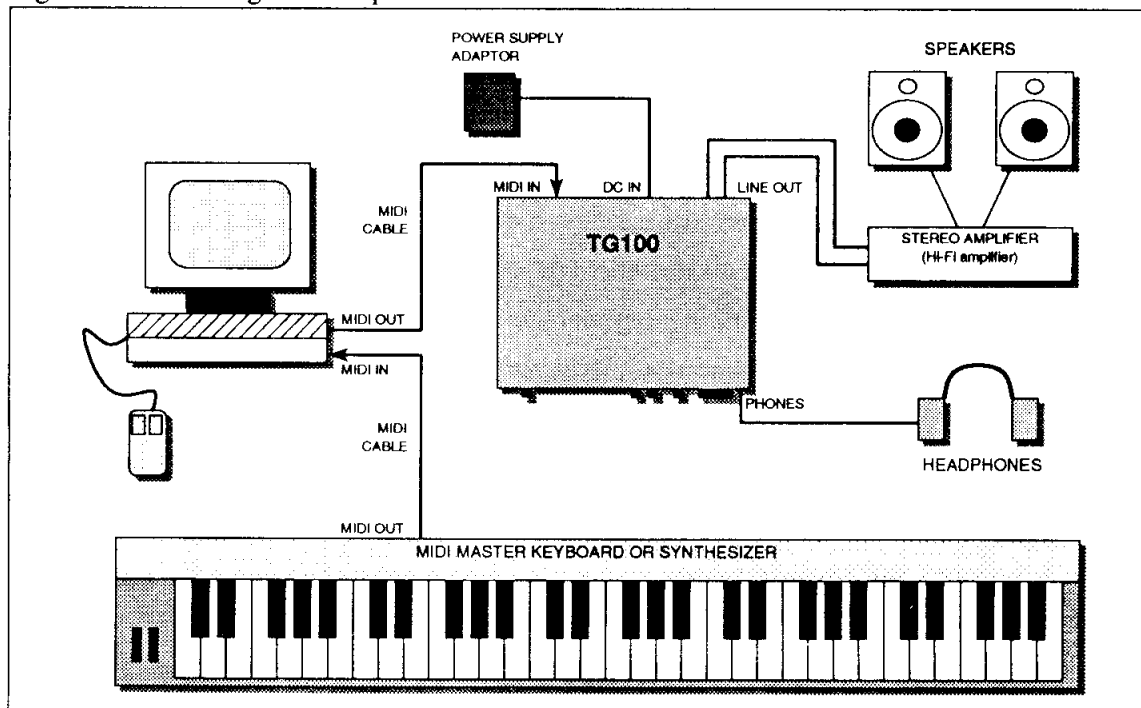

Settings

- 1) For this tutorial, the TG100's Sound module mode must be General MIDI. If the first letter of the above LCD is not "G", the Sound module mode must be set. See "Selecting the sound module mode" on page 16 of the *Reference Manual*.
- 2) Set the input selector on your amplifier to the input that the TG100 is connected to.
- 3) Set your MIDI keyboard so that its MIDI transmit channel is "1".
- 4) To simplify operation, set sequencer tracks 1 to 16 to MIDI channels 1 to 16. Now, track "1" corresponds to TG100 Part "1", track "2" to TG100 Part "2", etc.
- 5) Select sequencer track "1".
- 6) Set your amplifier's volume control to the position used for normal listening.
- 7) Turn up the TG100's "MASTER VOLUME" control while playing your MIDI keyboard.

If everything is OK, you will be playing, and hearing voice no. 1, Acoustic Grand piano.

If you don't hear anything, check the following.

- Is all your equipment switched on.
- Is your MIDI keyboard and sequencer set to the correct MIDI channel.
- Is the MIDI sequencer's "MIDI THRU" option turned on.
- Check the audio, and MIDI connections.
- Is the TG100's "HOST SELECT" switch set to MIDI.
- Make sure the TG100's MASTER VOLUME control is turned up.
- Check the settings on your amplifier: input selector, volume, speakers, headphones, etc.
- See "Troubleshooting" on page 63 of the *Reference Manual*.

Tracks can now be recorded and MIDI Program Change messages can be sent to the TG100 to select different voices for each of the TG100's Parts.

6 Using the TG100 with a computer that does not have a MIDI interface (TO HOST)

In this tutorial the TG100 is used with a computer that does not have a MIDI interface. If you are not sure how to connect your computer, please consult your Yamaha dealer.

What you will need

- 1) The TG100 and its power supply adaptor (PA-1505).
- 2) A MIDI master keyboard or synthesizer.
- 3) A computer with a serial port (RS-232C, or RS-422).
- 4) MIDI sequencing software that supports the TG100's TO HOST connection.
- 5) A stereo amplifier and connecting cable, or stereo headphones. If your headphones are fitted with a 1/4" (6.35mm) jack connector, you will need a stereo 3.5mm to 1/4" jack adaptor.
- 6) One MIDI connecting cable and a special "HOST" cable. See "Host computer connecting cables" on page 67 of the *Reference Manual*.

Making the connections

Before making any connections, make sure that all your equipment is switched off and the TG100's power supply adaptor is not plugged into the wall-power (mains) outlet.

- 1) Connect the MIDI cable from your MIDI keyboard's "MIDI OUT" connector to the TG100's "MIDI IN" connector.
- 2) Connect the "HOST" cable from the TG100's "TO HOST" connection to your computer's serial port.
- 3) Connect the TG100's "LINE OUT", "R" and "L/MONO" connectors to the inputs of your amplifier (if your amplifier has only one input, connect only the TG100's "L/MONO" connector). Or, if you are using stereo headphones, connect them to the TG100's "PHONES" connector.
- 4) Connect the power supply adaptor to the TG100's "DC IN" connector.
- 5) Plug the power supply adaptor into a wall-power (mains) outlet.

Switching on the power

- 1) Before switching on the power, set the "HOST SELECT" switch to the type of computer being used, either "Mac", "PC-1", or "PC-2". See "Connecting to a computer" on page 53 of the *Reference Manual* for full details.
- 2) Turn down the TG100's "MASTER VOLUME" control, then press the TG100's "POWER" switch. On the TG100's LCD, the message "YAMAHA TG100" will be shown for a few seconds, then the LCD shown below will appear.

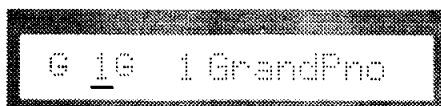

- 3) Switch on your MIDI keyboard.
- 4) Switch on your computer and load your MIDI sequencing software.
- 5) Turn down your amplifiers volume control, then switch on your amplifier.

Figure 3. Connecting to a computer that does not have a MIDI interface.

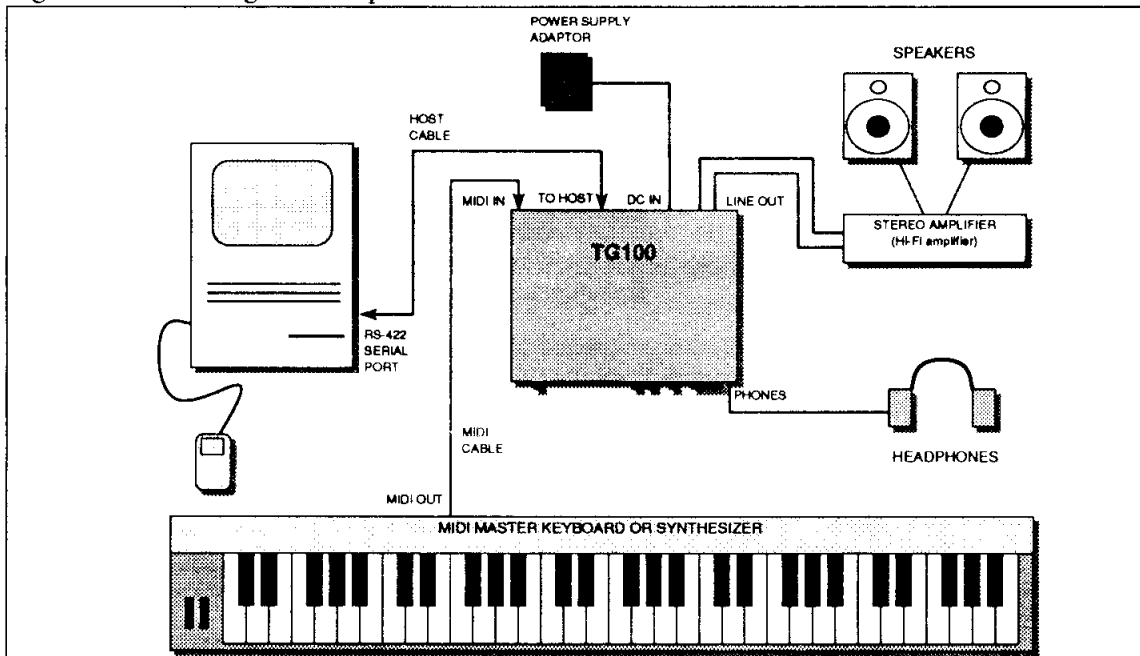

Settings

- 1) For this tutorial, the TG100's Sound module mode must be General MIDI. If the first letter of the above LCD is not "G", the Sound module mode must be set. See "Selecting the sound module mode" on page 16 of the *Reference Manual*.
- 2) Set the input selector on your amplifier to the input that the TG100 is connected to.
- 3) Set your MIDI keyboard so that its MIDI transmit channel is "1".
- 4) Your MIDI sequencer should be set to "Standard MIDI interface".
- 5) To simplify operation, set sequencer tracks 1 to 16 to MIDI channels 1 to 16. Now, track "1" corresponds to TG100 Part "1", track "2" to TG100 Part "2", etc.
- 6) Select sequencer track "1".
- 7) Set your amplifier's volume control to the position used for normal listening.
- 8) Turn up the TG100's "MASTER VOLUME" control while playing your MIDI keyboard.

If everything is OK, you will be playing, and hearing voice no. 1, Acoustic Grand piano.

If you don't hear anything, check the following.

- Is all your equipment switched on.
- Is your MIDI keyboard and sequencer set to the correct MIDI channel.
- Is the MIDI sequencer's "MIDI THRU" option turned on.
- Check the audio, and MIDI connections.
- Is the TG100's "HOST SELECT" switch set correctly.
- Make sure the TG100's MASTER VOLUME control is turned up.
- Check the settings on your amplifier: input selector, volume, speakers, headphones, etc.
- See "Troubleshooting" on page 63 of the *Reference Manual*.

Tracks can now be recorded and MIDI Program Change messages can be sent to the TG100 to select different voices for each of the TG100's Parts.

7 Editing & Saving Voices

In this tutorial we will edit a voice, give it a new name and then save it to a MIDI data recorder.

Important note about editing voices

Only voices in the Internal voice bank can be edited. When the TG100 is switched on, voices 1...64 from the General MIDI voice bank are copied into the Internal voice bank. To edit one of the other voices it must first be copied into the Internal voice bank.

When the TG100 is switched off, edited voices in the Internal Voice Bank will be lost. If you want to keep the voices that you have edited, they must be saved to a MIDI data recorder using the TG100's Dump All function.

Editing the voice

In this tutorial we will change the volume of an element used by voice No. 64, "Synthbrass 2".

- 1) Switch on the TG100 and your other equipment.
- 2) In play mode, move the cursor, using the [CURSOR] button, to the BK position.



G 1 @ 1 GrandPno

- 3) Use the [-1/NO] and [+1/YES] buttons to select the Internal Voice Bank "I".

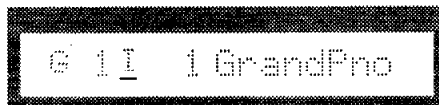

G 1 I 1 GrandPno

- 4) Move the cursor to the PC# position, then using the [+1/YES] button, select voice No. "64 Synbras2".



G 1 I 64 SynBras2

- 5) Repeatedly press the [EDIT] button until the following LCD display is shown.

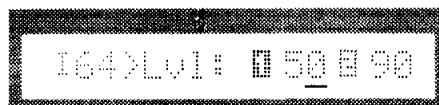

164>Lvl: [] 50 [] 90

- 6) Press the [-1/YES] button to change the value from 50 to 95. You have now created a new voice, based on the "64 Synbras2" voice.

Giving the edited voice a new name

Now that we have edited the "64 Synbras2" voice, we will give it a new name.

- 1) Repeatedly press the [EDIT] button until the following LCD display is shown.

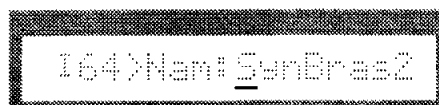

164>Nam: SynBras2

- 2) Use the [CURSOR] button to position the cursor under the character that you want to change, and the [-1/NO] and [+1/YES] buttons to change the character. Characters that can be used for voice names are shown on page 44, "Naming voices", in the *Reference Manual*.
- 3) We've changed the voice name to "SynBras3", as shown below.



- 4) Press the [PLAY] button to return to play mode.

Saving the edited voice

We've edited the voice and given it a new name. If we want to keep it we must save it to an MDR (MIDI data recorder) using the TG100's Dump All function.

The MIDI data recorder (MDR), could be any one of the following:

- 1) A MIDI sequencer program that can save and load MIDI Bulk Dump data, running on a computer.
- 2) A MIDI librarian program, running on a computer.
- 3) A dedicated MIDI sequencer (Hardware sequencer) that can save and load MIDI Bulk Dump data, such as Yamaha's QX3.
- 4) A dedicated MIDI data recorder, such as Yamaha's MDF2.
- 5) A music synthesizer with an MDR (MIDI Data Recorder) function, such as Yamaha's SY99 music synthesizer.

When the TG100's bulk dump function is used, all 64 voices in the Internal Voice Bank are transmitted to the awaiting MIDI data recorder.

With the "HOST SELECT" switch set to "MIDI", Internal Voice Bank data is transmitted via the "MIDI OUT" connection. With the switch set to "Mac", "PC-1", or "PC-2", the data is transmitted via the "TO HOST" connection.

Figure 4. MIDI data recorder connection

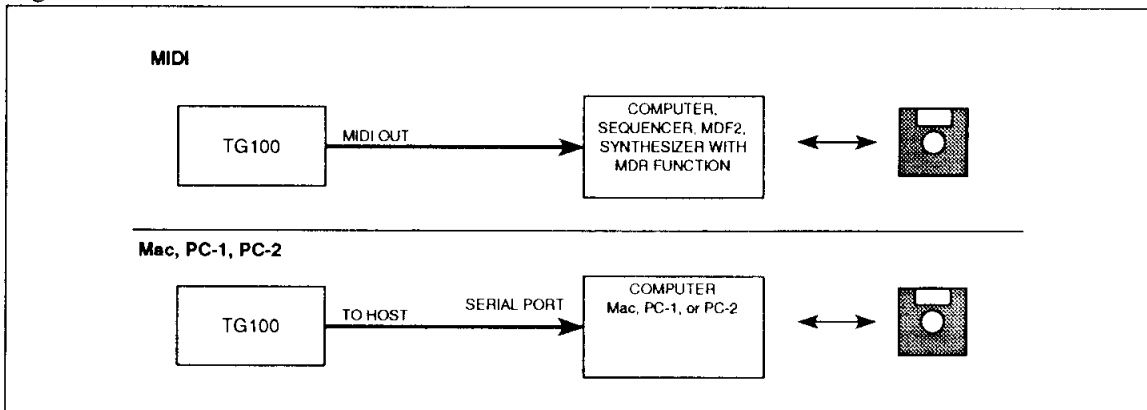

Before the Internal Voice Bank data can be transmitted, the TG100's "MIDI Exclusive on/off parameter must be set to "ON". With some MIDI data recorders, you may have to set the TG100 and the MIDI data recorder to the same MIDI device number. Check your MIDI data recorder's *Operating Manual*.

- 1) With the cursor at the leftward position, as below, simultaneously press the [PART] and [EDIT] buttons.



E 11 645Br3

- 2) Repeatedly press the [EDIT] button until the following LCD display appears.

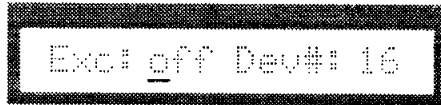

Exc: off Dev#: 16

- 3) Press the [+1/YES] button to switch “Exc: on”. Then, press the [CURSOR] button and use the [-1/NO] and [+1/YES] buttons to set the “Dev#:” number to “1” (the Dev number is the MIDI channel number).

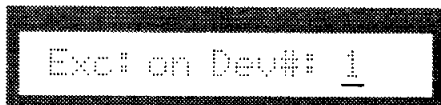

Exc: on Dev#: 1

- 4) Press the [EDIT] button once. The following LCD display will appear.

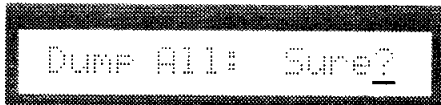

Dump All: Sure?

- 5) Press the [+1/YES] button to transmit the Internal Voice Bank data. The following LCD message will be shown during the transmission.

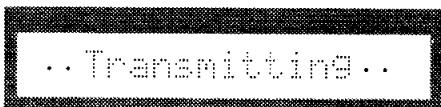

.. Transmitting..

When the transmission is complete, and the MDR (MIDI data recorder) has received all the data, the MDR will allow you to save the data for future use.

The Internal Voice bank data can be transmitted back to the TG100 from the MIDI data recorder. See your MDR's *Operating Manual* for details.

You might use a different Internal Voice bank for all your compositions. Each TG100 setup could be saved with the same name as the composition. Then, when you want to do some more work on a composition, just reload the data that corresponds to that composition into the TG100, and you're ready to go.

NOTE: Although you can save the System Mode settings, Multi Common Edit settings, Sound Module mode setting and Part to Voice assignments as MIDI Bulk Dump data, they are actually stored by the TG100 when the power is turned off. For Multi Part Edit, only the selected voice bank, voice and MONO/POLY mode settings are stored when the power is turned off.

YAMAHA