

16-573-101
JULY 1989

Williams 
ELECTRONICS GAMES, INC.



OPERATIONS MANUAL

including
Essential Information concerning
Game Operation & Adjustments,
Game Testing & Problem Diagnosis,
Parts Information, &
Reference Diagrams

POLICE FORCE ROM and Jumper Table

Game	System 11B CPU Rev.	P/N - U15 Game µP	P/N - U27 G. ROM 1	P/N - U26 G. ROM 2	P/N - U21 S. ROM 1	P/N - U22 S. ROM 2	P/N - U24 Sound µP	Jumpers
BIG GUNS	-	5400-09150-00	A-5343-557-2	A-5343-557-1	A-5343-557-4	A-5343-557-3	5400-09150-00	W1, 2, 4, 5, 7, 8, 11, 14, 16, 17, and 19
SPACE STATION	-		A-5343-552-2	A-5343-552-1	A-5343-552-4	A-5343-552-3		W1, 2, 4, 5, 7, 8, 11, 14, 16, 17, and 19
CYCLONE	-		A-5343-564-2	A-5343-564-1	A-5343-564-4	A-5343-564-3		W1, 2, 4, 5, 7, 8, 11, 14, 16, 17, and 19
BANZAI RUN	-		A-5343-566-2	A-5343-566-1	A-5343-566-4	A-5343-566-3		W1, 2, 4, 5, 7, 8, 11, 14, 16, 17, and 19
SWORDS OF FURY	-		A-5343-559-2	A-5343-559-1	A-5343-559-4	A-5343-559-3		W1, 2, 4, 5, 7, 8, 11, 14, 16, 17, and 19
TAXI	-		A-5343-553-2	A-5343-553-1	A-5343-553-4	A-5343-553-3		W1, 2, 4, 5, 7, 8, 11, 14, 16, 17, and 19
JOKERZ	-		A-5343-567-2	A-5343-567-1	A-5343-567-4	A-5343-567-3		W1, 2, 4, 5, 7, 8, 11, 14, 16, 17, and 19
EARTH-SHAKER	-		A-5343-568-2	A-5343-568-1	A-5343-568-4	A-5343-568-3		W1, 2, 4, 5, 7, 8, 11, 14, 16, 17, and 19
Black Knight 2000	-		A-5343-563-2	A-5343-563-1	A-5343-563-4	A-5343-563-3		W1, 2, 4, 5, 7, 8, 11, 14, 16, 17, and 19
POLICE FORCE	-		A-5343-573-2	A-5343-573-1	A-5343-573-4	A-5343-573-3		W1, 2, 4, 5, 7, 8, 11, 14, 16, 17, and 19

POLICE FORCE Solenoid Table

Sol. No.	Function	Solenoid Type	Wire Color	Connections		Driver Trmstr	Solenoid Part Number Flashlamp Type <small>i = Insert Bd; p=Playfield; d= Dome</small>
				CPU Bd	Playfield/Cabinet		
01A ³	Outhole Kicker	Switched	Vio-Brn	1P11-1	5J1-9: 5J4-9 (A)	Q33	AE-23-800
01C ³	Shark Flashers	Switched	Blk-Brn	(Gry-Brn)	5J5-9 (C)	Q33	#906/#89 flashlamps 1p,1i
02A ³	Top Left Eject	Switched	Vio-Red	1P11-3	5J1-7: 5J4-8 (A)	Q25	AE-23-800
02C ³	Croc Flashers	Switched	Blk-Red	(Gry-Red)	5J5-8 (C)	Q25	#906/#89 flashlamps 1p,1i
03A ³	Ball Diverter	Switched	Vio-Orn	1P11-4	5J1-6: 5J4-7 (A)	Q32	AE-26-1200
03C ³	Ret Flashers	Switched	Blk-Orn	(Gry-Orn)	5J5-7(C)	Q32	#906/#89 flashlamps 1p,1i
04A ³	Right 3-Bank Drop Tgt Reset	Switched	Vio-Yel	1P11-5	5J1-5: 5J4-6 (A)	Q24	AE-26-1200
04C ³	Weasel Flashers	Switched	Blk-Yel	(Gry-Yel)	5J5-5 (C)	Q24	#906/#89 flashlamps 1p,1i
05A ³	Lwr Right Eject	Switched	Vio-Grn	1P11-6	5J1-4: 5J4-5 (A)	Q31	AE-23-800
05C ³	Jackpot/Scoop Flashers	Switched	Blk-Grn	(Gry-Grn)	5J5-4 (C)	Q31	#906/#89 flashlamps 1p,2
06A ³	Mdl 3-Bank Drop Tgt Reset	Switched	Vio-Blu	1P11-7	5J1-3: 5J4-4 (A)	Q23	AE-26-1200
06C ³	Million Flasher	Switched	Blk-Blu	(Gry-Blu)	5J5-3 (C)	Q23	#906 flashlamp 1p
07A ³	Knocker	Switched	Vio-Blk	1P11-8	5J1-2: 5J4-2 (A)	Q30	AE-23-800
07C ³	L Dome Flashers	Switched	Blk-Vio	(Gry-Vio)	5J5-2 (C)	Q30	#906 flashlamps 2d
08A ³	Top Right Eject	Switched	Vio-Gry	1P11-9	5J1-1: 5J4-1 (A)	Q22	AE-23-800
08C ³	R Dome Flashers	Switched	Blk-Gry	(Gry-Blk)	5J5-1 (C)	Q22	#906 flashlamps 2d
09	Take Highest Flashers	Controlled	Brn-Blk	1P12-1	5J2-9: 5J6-9: 2J4-3	Q17	#89 flashlamps 4a 1p,1i
10	Playfield Grn Illum Relay	Controlled	Brn-Red	1P12-2	5J2-8: 5J6-8: 2J4-5	Q9	5580-09555-01 4a
11	Backbox Grn Illum Relay	Controlled	Brn-Orn	1P12-4	5J2-6: 5J6-7: 2J4-6	Q16	5580-09555-01 4a
12	A/C Select Relay	Controlled	Brn-Yel	1P12-5	5J2-5	Q8	5580-09555-01 5
13	Skill Flasher	Controlled	Brn-Grn	1P12-6	5J2-4: 5J6-5	Q15	#906 flashlamp 1p
14	Top Cop Flashers	Controlled	Brn-Blu	1P12-7	5J2-4: 5J6-3	Q7	#906 flashlamps 2p
15	Car On/Off Motor	Controlled	Brn-Vio	1P12-8	5J2-2: 5J6-2	Q14	14-7953
16	Car Up/Down Relay	Controlled	Brn-Gry	1P12-9	5J2-1: 5J6-1	Q6	5580-09555-01 4a
17	Left Jet Bumper	Special #1	Blu-Brn	1P19-7	5J3-7: 5J7-7	Q75	AE-23-800
18	Left Kicker ("sling")	Special #2	Blu-Red	1P19-4	5J3-6: 5J7-6	Q71	AE-26-1500
19	Right Jet Bumper	Special #3	Blu-Orn	1P19-3	5J3-3: 5J7-3	Q73	AE-23-800
20	Right Kicker ("sling")	Special #4	Blu-Yel	1P19-6	5J3-4: 5J7-5	Q69	AE-26-1500
21	Lower Jet Bumper	Special #5	Blu-Grn	1P19-8	5J3-2: 5J7-2	Q77	AE-23-800
22	Ball Release (Shtr Lane Feeder)	Special #6	Blu-Blk	1P19-9	5J3-1: 5J7-1	Q79	AE-23-800
-	<u>Right Flipper</u> Lower Right Flipper	-	Orn-Vio [Blu-Vio] ²	1P19-1	2J6-5: 2J10-7 (2J10-1: 2J6-15)	-	FL11630/50VDC
-	<u>Left Flipper</u> Lower Left Flipper	-	Orn-Gry [Blu-Gry] ²	1P19-2	2J5-4: 2J10-8 (2J10-2: 2J6-4)	-	FL11630/50VDC

Notes 1. Wire colors, except flipper Orn-Vio and Orn-Gry, are ground connections (to coil terminal with unbanded end of diode). Flipper Orn-Vio and Orn-Gry wires connect from CPU Board to flipper switch. 2. Flipper connections shown in braces are from flipper switch to flipper coil. 3. "A" circuits are pulsed, when Sol. 12 is de-energized; "C" circuits are pulsed, with Sol. 12 energized. Wire colors in brackets are those from respective A and C terminals corresponding to the J1-terminal connection listed for the Aux Power Driver Bd, which controls the device pulsing by Sol. 12. 4. Relay is mounted on Relay Bd, (4a) p/n C-11998-1; (4b) C-11902-1. 5. Relay is mounted on Aux Power Driver Bd, D-12247 in the backbox.

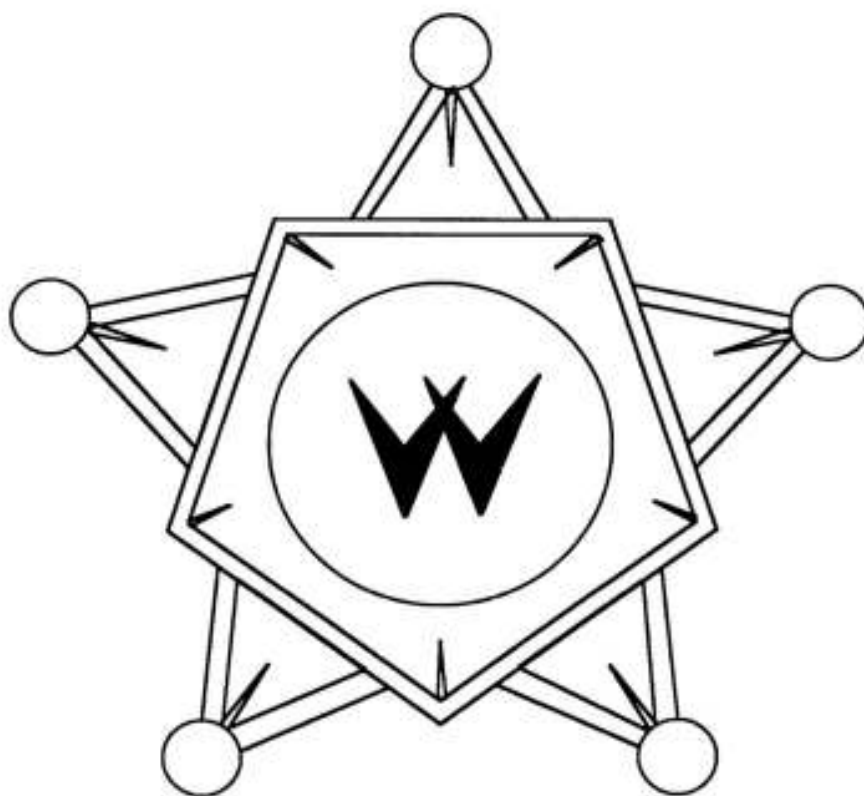

POLICE FORCE

OPERATIONS MANUAL

PREPARING YOUR GAME FOR A NEW LOCATION (The *Easy* Way)

To get a fresh start in its new location, the operator must make sure that a game is "zeroed". After completing the physical installation, the operator must test the game to ensure that it is operating properly.

Following successful testing, the operator should enter the Game Adjustments, proceed to Ad 70 (Install Factory), and press the Credit button to cause the 'Yes' message to appear. Next, press the ADVANCE switch and observe that the 'Factory Setting' message appears, with accompanying sounds. This adjustment change makes the game "forget" all the data it had stored in memory from its last location, and allows it to start 'from scratch'. The game now has all the settings provided at the factory, including specifically, 3 balls per game and 25¢ per game.

To accommodate locations that desire a choice of 3-ball or 5-ball play with their option of prices (25¢ or 50¢ per game), Williams' POLICE FORCE provides an easy method (described below) to change from one setting to another.

PROCEDURE

To select a choice other than the factory setting for game pricing (3-ball game for 25¢), proceed to the 'Game Adjustments', and select your choice from the following list, then press the Game Start button until the word "YES" appears, and then press the ADVANCE button.

<u>Desired Price and Game</u>	<u>Game Adjust</u>
50¢, 5-ball game	Ad 58
25¢, 3-ball game	Ad 57
50¢, 3-ball game	Ad 56

Contents

Section 1 - Game Operation & Test Information

POLICE FORCE (System 11B) ROM Summary	1
Connector & Component Identification	2
POLICE FORCE Circuit Boards.	2
Figure 1. Locations Diagram - Game Circuit Boards and Major Mechanisms	3
POLICE FORCE Game Control Locations.	4
Figure 2. Pinball Game Controls Locations	4
Pinball Game Assembly Instructions	5
Figure 3. Pinball Assembly, Playfield Pitch Angle, and Leg Leveler Details	5
Game Operation	6
POLICE FORCE Game Status Displays	7
POLICE FORCE Audit Table	9
POLICE FORCE Game-specific Adjustments Table.	10
POLICE FORCE Game Adjustment Table	11
POLICE FORCE Game Difficulty Setting Table for US / Canadian / French Games	12
POLICE FORCE Game Difficulty Setting Table for German / European Games	12
Game Adjustment Procedure.	13
Items 01 - 05	14
06 - 12	15
13 - 23	16
24 - 30	17
31 - 36	18
37 - 43	19
44 - 49	20
50 - 52	21
53 - 58	22
POLICE FORCE Preset Game Adjustments Table for German/European Games	22
POLICE FORCE Preset Game Adjustments Table for French Games.	22
POLICE FORCE Preset Game Adjustments Table for US / Canadian Games.	23
59 - 63	23
64 - 70	24
Resetting the High Scores	25
Game Pricing & POLICE FORCE Pricing Table	26 - 27
Test/Diagnostic Procedures.	28
Music Test.	28
Display Test.	28
Sound Test	28
Lamp Tests & POLICE FORCE Lamp-Matrix Table.	29
Solenoid Test & POLICE FORCE Solenoid Table.	30
Special and Controlled Solenoids - Diagrams and Details	31
Figure 4. Typical Solenoid A/C Select Relay Circuit.	31
Switch Tests & POLICE FORCE Switch-Matrix Table.	32
C-side Test	33
Car Test	33
Ending the Diagnostic Tests	34
Auto Burn-in Mode	34
System-11B Memory Chip Test & CPU LED Indicator Codes Table	34 - 35
System-11B Sound Circuitry Tests	35
Problem Analysis Messages	36
Maintenance Information	37
Figure 5. Adjustments and Lubrication Points, Shooter Lane Feeder	37
Fuse Locations Diagram & Listing	38

Contents

Section 2 - Game Parts Information

Locations Diagram - Game Circuit Boards and Major Mechanisms (with Parts Listed)	40
Power Supply Board (D-12246) Parts Layout and Parts Listing	41
Aux Power Driver Board (D-12247-566) Parts Layout and Parts Listing	42
Audio Board Assembly (D-12338-573)	43
System 11B CPU Board Parts Layout and Parts Listing	44 - 45
Master Display Board (D-12232-2) Layout and Parts List	46
16-Character Display Glass (used on Master Display Board).	47
Backbox Interconnect Board (D-12313-573) Parts Layout and Parts Listing	47
Lamp Board ("3-L", C-12709; 3-R", C-12710; "1", B-12224) Assemblies Parts Lists.	48
Lamp Board ("6-L", C-12711; "6-C1", C-12712; "6-C2", C-12713) Assemblies Parts Lists.	48
Relay Board (Sol. 10 & 11 Gen. Illum) (C-11998-1) Diagram and Parts Listing.	48
Lamp Board ("3-C", C-12000; Top Light, C-12717; City Jail, C-12716) Assemblies Parts Lists	49
Lamp Board (Firing Range, C-12698) & Slave Display Assembly (C-8364-1) Parts Lists.	49
Lower Right Flipper (C-11626-R-3) Parts Layout, List & Notes.	50
Lower Left Flipper (C-11626-L-3) & Flipper Link (A-10656) Assemblies Parts Layouts & Lists.	51
Kicker Arm (Slingshot) Assembly (B-12665) and Associated Parts	52
Ball Trough Switches & Knocker Assembly (B-10686-1) Parts Layouts and Lists	53
Shooter Lane Feeder (C-9638-3) & Outhole Kicker (B-8039-2) Parts Layouts and Lists	54
BR, TL and TR Eject Hole Arm Assemblies (B-9361-R-8, -6, & -1) Parts Layout and Lists	55
Jet Bumper (B-9414-1) & Jet Bumper Coil Assembly (B-9415-1) Parts Layout and Lists	56
Right Ramp Diverter Assembly (C-12808) Parts Layout and List	57
Idler Pulley (B-12803), Traverse Bracket (B-12800), & Spinning Target (B-12875) Parts Lists.	58
Police Car (B-12805), Car LED Assy (C-12678) & Car Motor Bracket (B-12806) Parts Lists	59
Back Panel Assembly (Jail House, Lamps, and Diverter) (D-12822) Parts Layout and List	60
Inner Ramp (D-12786) & Outer Ramp (R-12787) Parts Listing	61
3-Bank Drop Target (C-11223-1) Parts Layout Diagram and Parts Listing.	62
3-Bank Opto Board (C-12559) & Standup Target Assemblies Parts Layout and Parts Listing	63
Coin Door Assembly (09-17002-x & 09-17003-x) Parts Listing and Parts Diagram.	64 - 65
Playfield Posts Diagrams and Listing; Rubber Parts Listing	66 - 67
Backbox Parts Diagram and Listing & Miscellaneous POLICE FORCE Parts.	68
Solenoids/Flashers	69
Switches: Listing, Matrix Diagram, and Typical Switch Circuit.	70 - 71
Lamps: Listing, Matrix Diagram, and Typical Lamp Circuit.	72 - 73
Playfield Parts.	74
Unique POLICE FORCE Parts List.	75

Section 3 - Reference Diagrams & Schematics

Cabinet Wiring Diagram.	78
3-Bank Opto Board (C-12559) Layout and Schematic	79
Power Supply Board (D-12246) Layout and Schematic.	80 - 81
System 11B CPU Board (D-11883-573) Layout	82
Schematic, System 11B CPU (16-9019, Sheet 1, 2, 3, 4 of 4).	83 - 86
Master Display Board and Audio Board Layouts.	87
Master Display Board (D-12232-2) Schematic	88
Audio Board (D-11581-573) Schematic.	89
Aux Power Driver Board (D-12247-566) Schematic	90
Aux Power Driver Board and Backbox Interconnect Board Layouts.	91
Backbox Interconnect Board (D-12313) Schematic	92
Controlled, Special, and Switched Solenoids	93
Power Wiring Diagram.	94
Game Circuit Boards Interboards Signals	95 - 96
Diagnostic Test Flowchart.	97 - 98

CONNECTOR & COMPONENT IDENTIFICATION

WILLIAMS ELECTRONICS GAMES uses a special technique to identify connectors and other game components. Each plug or jack receives a prefix number (which identifies the circuit board), a letter, and a number. J-designations refer to the male part of a connector. P-designations refer to the female part of a connector. For example, 1J1 designates jack 1 of board 1 (a CPU Board jack); 3P6 designates plug 6 of board 3 (a Power Supply Board plug). Identifying the specific pin number of a connector involves a hyphen, which separates the pin number from the plug or jack designation. For example, 1J1-3 refers to pin 3 of jack 1 on board 1.

Other game components may also have similar prefixes preceding their designator to clarify their locations or related circuit.

Prefix numbers for the System 11B circuit boards and other major assemblies are listed below. A prefix number may precede a component designator to identify its associated unit (e.g., Backbox fuse 6F1).

1 - CPU	5 - Aux Power Driver	9 - Insert Board
2 - Master Interconnect	6 - Backbox	10 - Audio
3 - Backbox Power Supply	7 - Cabinet	
4 - Alphanumeric Display	8 - Playfield	

POLICE FORCE CIRCUIT BOARDS

System 11B Circuit Boards for **POLICE FORCE** are in the backbox. They are accessible by unlocking the Backbox lock, removing the Backbox glass, unlatching the Insert Board, and swinging it open.

The Master Display Board is mounted on the front of the Insert Board, along with the 7-Segment Display Board. To access the Master Display Board, unlock the Backbox and remove the Backbox glass.

Lamp circuit boards are mounted on the Playfield and on top of the Backbox under the **POLICE FORCE** Dome.

CPU BOARD. The System 11B CPU Board (p/n D-11883-573) must be equipped with the ROMs specified in the **POLICE FORCE** (System 11B) ROM Summary. CPU Board jumpers W1, W2, W4, W5, W7, W8, W11, W14, W16, W17, and W19 must be connected.

AUDIO BOARD. The Audio Board is p/n D-11581-573, including ROMs and microprocessor.

DISPLAY BOARD. The Alphanumeric Display Unit Board is p/n D-12232-2.

POWER SUPPLY BOARD. The Power Supply Board is p/n D-12246.

AUX POWER DRIVER BOARD. The Aux Power Driver Board is D-12247-566.

MASTER INTERCONNECT BOARD. The Master Interconnect Board is D-12313-573.

Figure 1 shows the locations of these circuit boards, as well as other devices especially located to make **POLICE FORCE** a great game.

Section 1

Game Operation & Test Information

- **POLICE FORCE (System 11B) ROM Summary**
- **Pinball Game Assembly Instructions**
- **Game Play**
- **Game Status Displays**
- **Game Adjustment Procedure**
- **Game Pricing**
- **Test/Diagnostic Procedures**

POLICE FORCE (System 11B) ROM Summary

IC	DESCRIPTION	TYPE	IDENTIFIER	BOARD	PART NUMBER
Game ROM 1	32K x 8 ROM	27256	U27	CPU	A-5343-573-2
Game ROM 2	32K x 8 ROM	27256	U26	CPU	A-5343-573-1
Sound ROM 1	32K x 8 ROM	27256	U21	CPU	A-5343-573-4
Sound ROM 2	32K x 8 ROM	27256	U22	CPU	A-5343-573-3
Music/Speech ROM1	32K x 8 ROM	27256	U4	Audio	A-5343-573-5
Music/Speech ROM1	32K x 8 ROM	27256	U19	Audio	A-5343-573-6

NOTICE

To order a replacement ROM from your authorized WILLIAMS ELECTRONICS GAMES distributor, specify: (1) part number (if available); (2) ROM label color; (3) ROM level (number) on the label; (4) which game the ROM is used in.

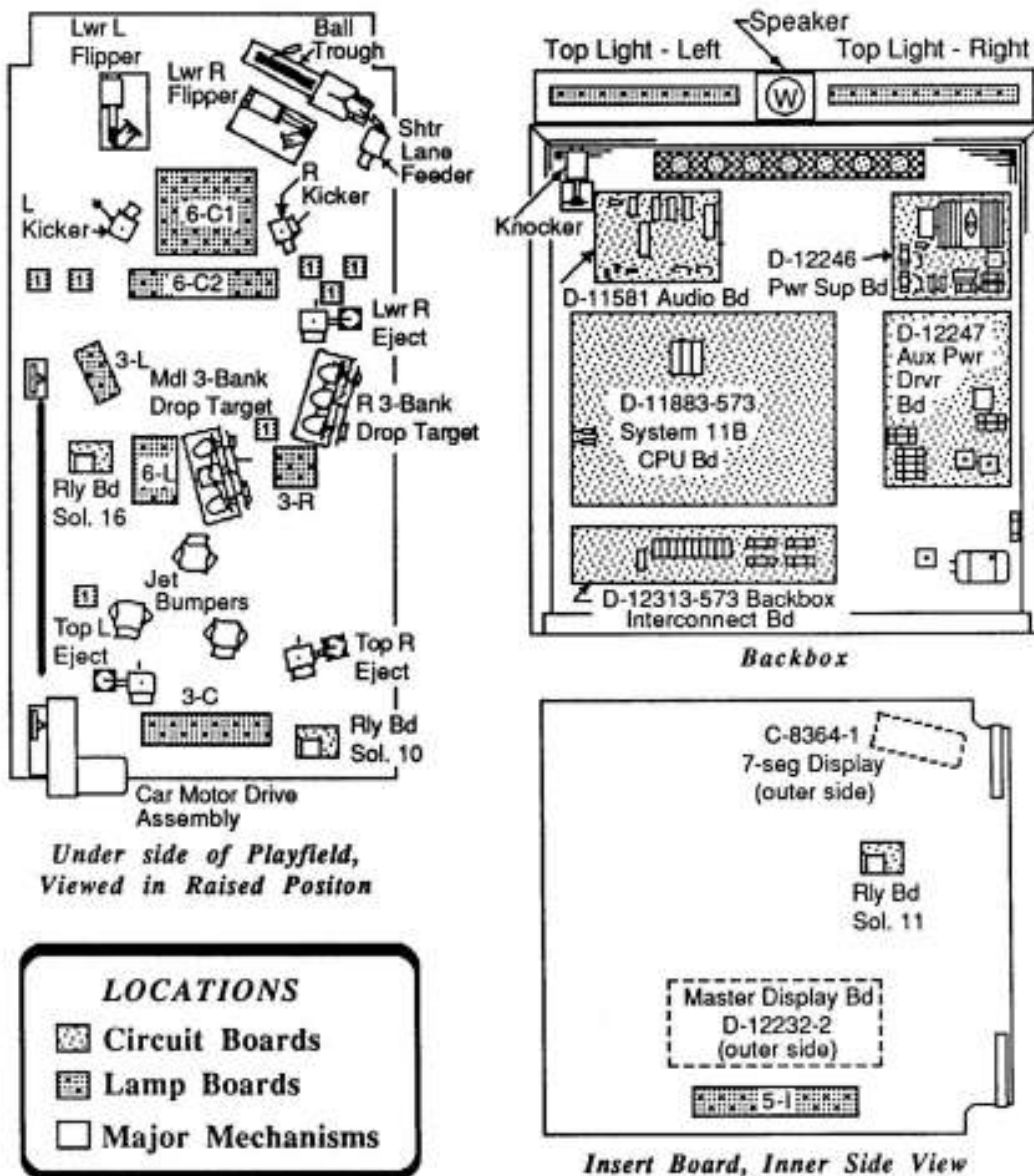

Figure 1. Locations Diagram - Game Circuit Boards and Major Mechanisms

POLICE FORCE GAME CONTROL LOCATIONS

Figure 2 shows the locations of the following switches, except for the last two (CPU and Sound Diagnostic switches, which are shown in the Backbox portion of Figure 1, along the left edge of the CPU Board).

The On-Off switch is on the bottom of the cabinet near the right front leg.

The Volume Control is on the left inner wall of the cabinet on the tilt mechanisms board. It is accessible by opening the coin box door.

The Credit switch is a pushbutton to the left of the coin door on the cabinet exterior.

GAME ADJUSTMENT/DIAGNOSTIC SWITCHES. **POLICE FORCE** allows the operator to control all game adjustments, obtain bookkeeping information, and diagnose problems, using only three switches mounted on the inside of the coin door, along with the Credit button beside the coin door.

ADVANCE, AUTO-UP/MANUAL-DOWN, and HIGH-SCORE RESET are the switches located on the inside of the coin door. Refer to the text discussing Game Status Displays and the Test/Diagnostic Procedures for details concerning button operation.

The Memory Protect switch is on the inside frame of the coin door. This interlock switch must be open to clear bookkeeping totals and to make game adjustments. It automatically opens, when the coin door opens.

Figure 1 shows the locations of the two CPU Board switches (left edge of CPU Board, Backbox View).

The CPU Diagnostic switch (SW 2) is the lower switch (of the two switches mounted on the left edge of the CPU Board) near a large, socketed microprocessor chip. This switch initiates the Memory Chip Test explained in the Test/Diagnostic Procedures.

The Sound Diagnostic switch (SW 1) is the upper switch of the two mounted on the left edge of the CPU Board. This switch initiates the Sound Section Test. Refer to the Test/Diagnostic Procedures.

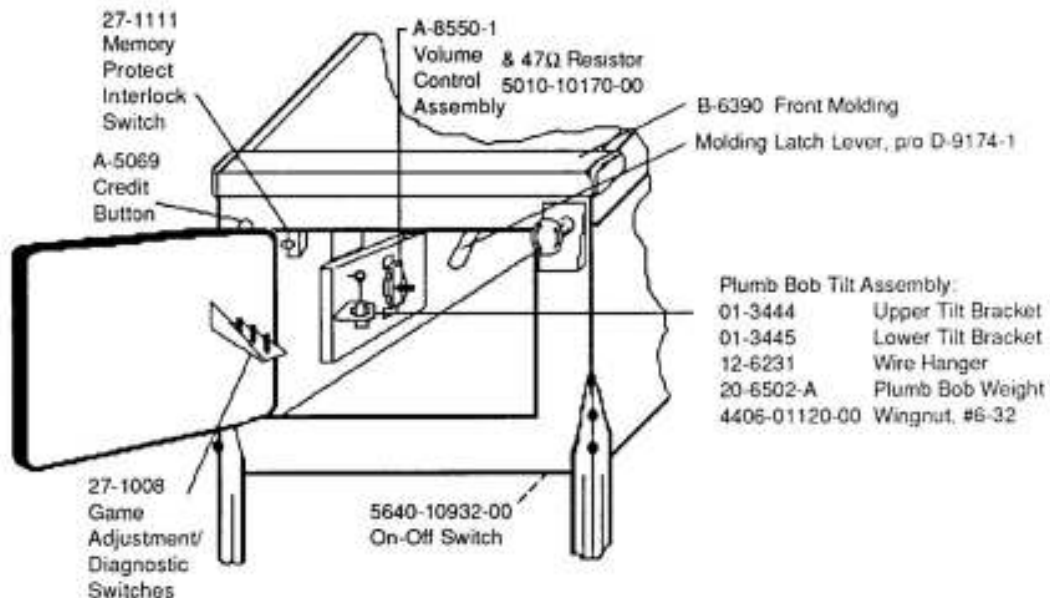

Figure 2. Pinball Game Controls Locations

PINBALL GAME ASSEMBLY INSTRUCTIONS

1. Open the shipping container; remove all cartons, parts, and other items, and set them aside.
2. Place cabinet on a support and attach rear legs (after installing leg levellers), using leg bolts. Leg levellers and leg bolts are both provided among the parts in the cash box.
3. Attach the front legs (after installing leg levellers), using leg bolts. See Figure 3 for details.

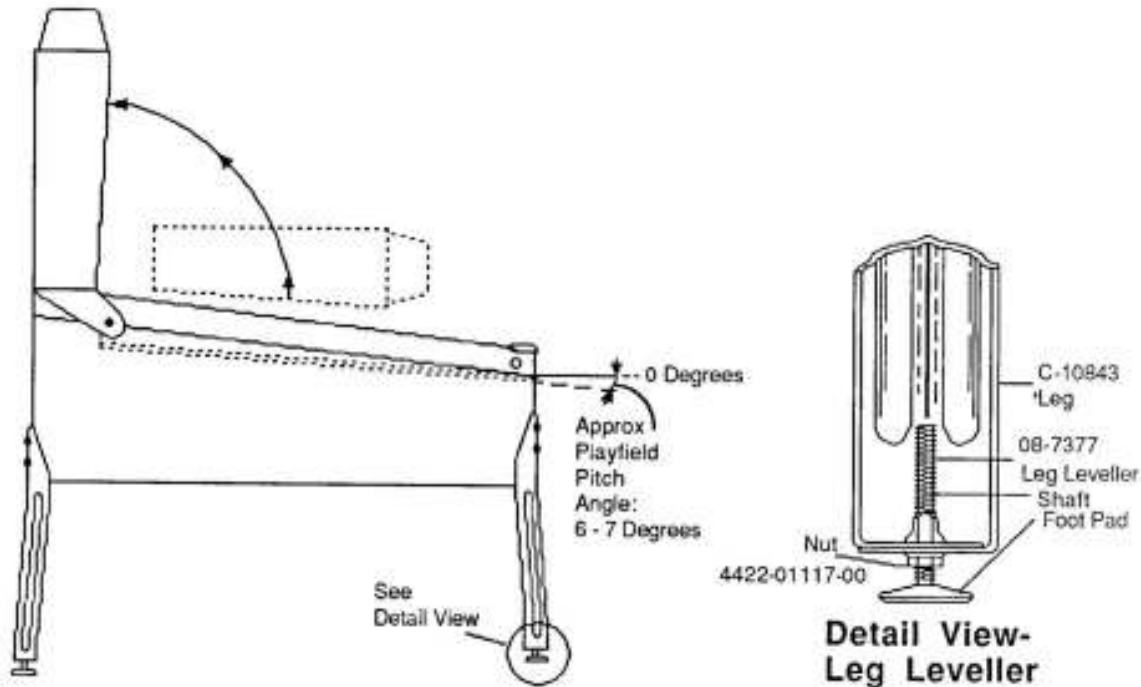

Figure 3. Pinball Assembly, Playfield Pitch Angle, and Leg Leveller Details.

4. Reach into the cabinet and backbox and ensure that the interconnecting cables are free to move (not kinked or pinched). Be careful to avoid damaging wires at any stage of the assembly process.
5. Raise the hinged backbox upright and stabilize it into position. Unlock the backbox, and remove the backbox glass, storing it carefully to avoid scratches. Remove the shipping block holding the Insert Board. Unlatch the Insert Board and open it. This allows access to the bolt holes used for securing the backbox upright. Install the mounting bolts, lockwashers, and flat washers through the bottom holes of the backbox into the threaded fasteners in the cabinet to secure the backbox. Close the Insert Board and latch it in position. Reinstall the backbox glass, and lock the backbox.

WARNING

NEVER transport a pinball game with the hinged backbox erect. Always lower the backbox forward onto the playfield cabinet on a layer of protective material to prevent marring or damage and possible personal injury.

6. Extend each leg leveler *slightly* below the leg bottom, so that all four foot pads are extended about the same distance. Remove the cabinet from its support and place it on the floor.
7. Unlock and open the coin door. Locate the Molding Latch Lever (shown in Figure 2), and move the lever toward the left side of the game, to release the Front Molding. Lift the Front Molding off the playfield cover glass; return the Latch Lever toward the right, and close the coin door. *Carefully* slide the glass downward, until it clears the grooves of the Left and Right Side Moldings. Lift the glass up and away from the game, storing it carefully to avoid breakage.

PINBALL GAME ASSEMBLY INSTRUCTIONS (Continued)

- Place a level or an inclinometer on the playfield surface. Adjust the leg levellers for proper playfield level (side-to-side) and playfield pitch angle (incline) of approximately 6-7 degrees. NOTE: It is recommended that these measurements be made ON the playfield, not the cabinet nor the playfield cover glass. Tighten the nut on each leg leveller shaft to maintain this setting, as shown in Figure 3.

CAUTION

Playfield pitch angle adjustments can affect the operation of the plumb bob tilt, inside the cabinet. The plumb bob weight is among the parts in the cash box; the operator should install the weight and adjust this tilt mechanism for proper operation, after completion of the desired playfield pitch angle setting.

- Move the game into the desired location; recheck the level and pitch angle of the playfield.
- Verify that the **required number** of balls are installed in the game. (**POLICE FORCE**: 2 balls.)
- Clean and reinstall the playfield cover glass, reversing the procedure of step 7. Prepare the game for player operation.

GAME OPERATION

WARNING

After assembly and installation at its site location, this game must be plugged into a properly grounded outlet to prevent shock hazard, and to assure proper game operation. DO NOT use a 'cheater' plug to defeat the ground pin on the line cord. DO NOT cut off the ground pin.

POWERING UP. Perform the following 'power up' routine upon completion of the assembly and installation procedure, as well as at the beginning of each period of game operation. Initially, it will confirm that the game is in proper operating condition; later, it will aid the operator via its messages.

Procedure. With the coin door closed, plug the game in, and switch it ON, using the On-Off switch. In normal operation, the player 1 score display initially shows 00. Then, the game goes into the Attract Mode (playfield and backbox lamps flashing, sounds being heard, etc., if the operator does not change the Factory Setting).

Open the coin door and press the AUTO-UP/MANUAL-DOWN switch to MANUAL-DOWN. Press the ADVANCE button to begin the game test routine. Return to AUTO-UP and perform the entire test routine to verify that the game is operating satisfactorily. Successful completion of the tests shows that the game is ready to begin earning your investment return.

After the game has been on location for a period of time, the test routine may be preceded by messages concerning game problems. The text entitled 'Problem Analysis Messages' at the end of the Text/Diagnostic Procedures contains more details concerning messages displayed at each game turn-on.

ATTRACT MODE*. Playfield and backbox lamps blink. The player score displays exhibit a series of messages informing the player concerning:

- Recent highest scores*;
- A "custom message"
("BE TOP COP ... PLAY ... POLICE FORCE"*);
- The score to achieve to obtain a Replay award*;

These (or similar) displays reappear occasionally, accompanied by sounds and music, until a player initiates game play by inserting a coin or, when credits are available, pressing the Credit button.

GAME OPERATION (Continued)

CREDIT POSTING. Insert coin(s). A sound is heard for each coin, and the player score displays show the number of credits purchased. So long as the number of maximum allowable credits* are *NOT* exceeded by coin purchase or high score, credits are posted correctly.

STARTING A GAME. Press the Credit button once. A startup sound plays, and the Credit amount shown in the player score display decreases by one. The upper Player Score Display flashes 00 (until the first playfield switch is actuated), and the lower Player Score Display shows **ball 1**, except for 4-player games where the **ball #** shows in the individual player's display. Additional players may enter the game by pressing the Credit button once for each player, before the end of play on the first ball.

TILT. Actuating the Slam Tilt switch on the coin door inside the cabinet ends the current game; **POLICE FORCE** then proceeds to the Game Over Mode. With the actuation of the playfield tilt switch, or the third closure* of the plumb bob tilt switch, the player loses the remaining play of that ball, but can complete the game.

END OF GAME. All earned scores and bonuses are awarded. If a player's final score exceeds the specified value, the player receives a designated award for achieving the current highest score. A random digit set* appears in the Match display. Credit* may be awarded, when the last two digits of any player's score display (1 through 4) match the random digits of the Match display. Match, high score, and game over sounds are made, as appropriate.

GAME OVER MODE. The GAME OVER display shows in the player score displays. Then, the high scores flash on the appropriate player score displays. The game proceeds to the Attract Mode.

* - operator-adjustable feature

POLICE FORCE GAME STATUS DISPLAYS

POLICE FORCE provides the game owner/operator with a display of information concerning the game's bookkeeping and game play feature adjustments. Basically, three classes of information now become available in this status display mode: Id (Identification); Au (Audit); Ad (Adjustment). Each of the underscored two-letter abbreviations for these classes appears in the Player Score Displays, while the system microprocessor for the **POLICE FORCE** game is displaying the items within each class.

Identification Information--Id

With the game turned on, the coin door open, and the AUTO-UP/MANUAL-DOWN switch in the AUTO-UP position, the operator can press the ADVANCE switch once, briefly. Player displays immediately change from the Attract Mode to the Game Status Display or Identification (Id) Mode. This is evident by the following display, shown in columnar form. The column headings refer to the two backbox displays.

Upper Player Score Display	Lower Player Score Display
POLICE FORCE	573 L-x* Id 00

* x - indicates ROM revision level; e.g., 1 is initial issue; 2, 3, etc. for later revisions.

The game is named in the upper Player Score display. The game's identification number, the ROM revision level, and the Id Mode stage (**Id 00**) shows in the Lower Player Score display.

Pressing ADVANCE once more causes the **Id 01** display to appear. This display describes the installed software more fully; that is, country; development stage; date of revision.

Pressing ADVANCE once more causes the **Id 02** display to appear. This display describes which of the "Install" options is currently in effect. For example, if the YES option of the INSTALL FACTORY Adjustment Item (**Ad 70**) was last selected, *FACTORY SETTING* appears on the player score displays. Changing the setting of any other game adjustment item, after selecting the YES option for **Ad 70** causes the display to change to *FACTORY ALTERED*. Similarly, if the operator selects the YES option for INSTALL HARD (**Ad 65**), the display indicates *HARD SETTING*. Changing a game adjustment item later then causes the display to show *HARD ALTERED*.

Audit Information--Au

While the AUTO-UP switch remains in the Up position, the operator can press the ADVANCE switch once, briefly, to begin the backbox displays of Audit (sometimes called "bookkeeping") Information. Fifty-three audit entries are now available. Calculation of the various factors is no longer necessary because the System 11B game program now performs all the mathematical factor computations. This information is intended to aid the owner/operator in evaluating how the game is performing in each location, by providing knowledge about which game features are receiving the most play. With this information, the owner/operator can determine whether adjusting the game features to other settings will contribute to increased game earnings.

The operator can press the ADVANCE button once to view each Audit Information display item. To proceed more rapidly through this information, the operator only has to press and hold the ADVANCE button. If a desired item is passed, the operator can use the MANUAL-DOWN switch position with the ADVANCE button to back up to the desired item.

The **POLICE FORCE Audit Table** lists the 53 Audit Items of the **POLICE FORCE** Game Status Displays. Presentation of these Audit Items again utilizes the player score displays: The Audit Item entry appears in the lower Player Score Display accompanied by the Item's data, while the upper display shows the Item description. A few example entries are shown in the table. Detection of erroneous data affecting any of the counters used in these audit items causes the message, **ERROR**, to be displayed during display of any audit item associated with that particular counter. (The program does not analyze the cause of the error; it merely alerts the operator of the error's existence by the message.)

POLICE FORCE GAME STATUS DISPLAYS (Continued)

POLICE FORCE Audit Table

Audit Item (Lower)	Descriptive Phrase (Upper Display)	Audit Item ¹ Value (Lower Display)
AU 01	LEFT COINS [chute next to coin door hinge]	432
02	CENTER COINS	0
03	RIGHT COINS	398
04	PAID CREDITS	830
05	TOTAL PLAYS	
06	TOTAL FREE (Total Free Plays)	
07	PERCENT FREE (% Free Plays)	
08	REPLAY AWARDS	
09	PERCENT REPLAY (% Replay Awards)	
10	SPECIAL AWARDS	
11	PERCENT SPECIAL (% Special Awards)	
12	MATCH AWARDS	
13	HSTD (High Score to Date) CREDITS	
14	PERCENT HSTD (% HSTD Credits)	
15	EXTRA BALLS	
16	PERCENT EX. BALL (% Extra Balls)	
17	AV. BALL TIME (Average Time in Seconds)	
18	MINUTES OF PLAY (Minutes of Play)	
19	BALLS PLAYED	
20	REPLAY1 AWARDS	
21	REPLAY2 AWARDS	
22	REPLAY3 AWARDS	
23	REPLAY4 AWARDS	
24	1 PLAYER GAMES	
25	2 PLAYER GAMES	
26	3 PLAYER GAMES	
27	4 PLAYER GAMES	
28	BURN IN CYCLES	
29	JACKPOT AWARDS (# of times 'JACKPOT' awarded)	
30	UNLIMITD MILLION (# of starts for 'Unlimited Million')	
31	MILLIONS AWARDED (# of millions awarded via 'Unl'd Million')	
32	TAKE HIGHEST (# of 'Take Highest Score' awards)	
33	MULTIBALLS (# of times for Multi-Ball™ play)	
34	ADVANCE X'S (# of times Bonus Multiplier advanced)	
35	'X' SPECIAL (# of Specials awarded via Bonus Multiplier)	
36	TOP COP AWARDED (# of 'Top Cop' awards)	
37	CONSOL. EX. BALLS (# of Consol. Ex. Balls awarded)	
38	TOP EXTRA BALLS (# of Ex. Ball awards from 'Top Target')	
39	H.S.RESET COUNTER	
40	0.0-0.4 MIL. SCORE (# of games <500K)	
41	0.5-0.9 MIL. SCORE (# of games ≥500K, <1M)	
42	1.0-1.4 MIL. SCORE (# of games ≥1M, <1.5M)	
43	1.5-1.9 MIL. SCORE (# of games ≥1.5M, <2.0M)	
44	2.0-2.9 MIL. SCORE (# of games ≥2.0M, <3.0M)	
45	3.0-3.9 MIL. SCORE (# of games ≥3.0M, <4.0M)	
46	4.0-4.9 MIL. SCORE (# of games ≥4.0M, <5.0M)	
47	5.0-5.9 MIL. SCORE (# of games ≥5.0M, <6.0M)	
48	6.0-7.9 MIL. SCORE (# of games ≥6.0M, <8.0M)	
49	8.0-9.9 MIL. SCORE (# of games ≥8.0M, <10.0M)	
50	10M - 99MIL. SCORE (# of games ≥10M, <99.9M)	
51	AV. MIN. GAME TIME (Average Game in Minutes)	
52	LEFT DRAINS (# of drains via Left Outlane)	
53	RIGHT DRAINS (# of drains via Right Outlane)	

NOTE:
 1. The numbers shown in this column for Items 1 through 4 are examples. Entries for all items depend on the amount of play; thus, they will vary from location to location.

POLICE FORCE GAME STATUS DISPLAYS (Continued)

Adjustment Information--Ad

At end of the Audit Information presentation, with the AUTO-UP switch in the Up position, the operator can press the ADVANCE button to proceed to the Adjustment Information portion of the **POLICE FORCE** Game Status Displays, as shown in the Player Score Displays. A list of the Game Adjustments appears in the **POLICE FORCE Game Adjustment Table**.

The operator can press the ADVANCE button once to view each Adjustment Information display item. To proceed more rapidly through this information, the operator only has to press and hold the ADVANCE button. If a desired item is passed, the operator can use the MANUAL-DOWN switch position with the ADVANCE button to back up to the desired item.

The **POLICE FORCE Game Adjustment Table** lists the 70 items of the Adjustment Information portion of the **POLICE FORCE** Game Status Displays. Presentation of the displays is similar to that for the Audit Information (that is, the upper display shows a descriptive phrase; the light type below the column headings names the respective backbox displays where the information appears, etc.).

The **POLICE FORCE Game-specific Adjustments Table** lists those Game-specific Adjustment items for which settings vary between the major models of pinball products.

The Game Adjustment Table, along with the Game-specific Adjustment Table, provides the Factory Settings for the three major models of pinball products (defined by its country/language designation).

POLICE FORCE Game-specific Adjustments Table

Adjustment Item (Lower)	Descriptive Phrase (Upper Display)	Factory Setting (Lower)		
		Domestic (US/Can.)	French	W Ger/ European
Ad 31	1/2 PRICE BUY IN	NO		
32	PROGRESSIVE / NORMAL / CONTEST GAME	Progress.		
33	LIBERALIZER	YES	NO	
46	EX. BALLS / GAME	33%		
47	SPECIALS / GAME	5%		
48	A. MODE SOUNDS	YES		NO
51	CONSOL. BALL TIME	45 sec	50 sec	
52	NORMAL / DIM / DIMMEST FLASHERS	NORMAL		

NOTE

In both of these tables, each Adjustment Item's Factory Setting for each of the three major models of pinball products is that shown in the 'Domestic' (US / Can.) column, unless a superseding entry appears in the French or West German columns of these tables. A superseding entry takes precedence over the 'Domestic' entry for the only the particular model indicated by its column.

POLICE FORCE GAME STATUS DISPLAYS (Continued)

POLICE FORCE Game Adjustment Table

Adjustment Item (Lower)	Descriptive Phrase (Upper Display)	Factory Setting 6 (Lower)		
		Domestic (US/Can.)	French	W Ger/ European
Ad 01	AUTO REPLAY ¹ or FIXED REPLAY ¹	10 (%)		
02	REPLAY START (or REPLAY LEVEL 1) ¹	SCORES		4,000,000
03	REPLAY LEVELS (or REPLAY LEVEL 2) ¹	5,000,000		02
04	(REPLAY LEVEL 3) ¹	01 (or OFF)		
05	(REPLAY LEVEL 4) ¹	(see text)		
06	REPLAY AWARD	Credit		
07	SPECIAL AWARD	Credit		
08	MATCH FEATURE	10 (%)	8%	
09	BALLS / GAME	03		
10	TILT WARNING	03	01	
11	MAXIMUM EX. BALL { [00 = NO Ex. Ball; 1-9 E. B. /Ball; 1-9 E. B. /B. I. P.; 1-9 E. B. /Game] }	3EB/BIP	1EB/BIP	
12	MAXIMUM CREDITS	10	20	30
13	HIGHEST SCORES	On		
14	BACKUP HI. SCR. 1	6,000,000		7,000,000
15	BACKUP HI. SCR. 2	5,500,000		6,500,000
16	BACKUP HI. SCR. 3	5,000,000		6,000,000
17	BACKUP HI. SCR. 4	4,500,000		5,500,000
18	HI. SCR. 1 CREDITS	01	03	03
19	HI. SCR. 2 CREDITS	01		00
20	HI. SCR. 3 CREDITS	01		00
21	HI. SCR. 4 CREDITS	01		00
22	H. S. RESET EVERY	3,000		1000
23	FREE PLAY	NO		
24	U.S.A. 1 COINAGE (1 COIN 1 PLAY) ^{2,3,4}	USA 1	French 1	German 2
25	LEFT UNITS	01	02	06
26	CENTER UNITS	04	10	12
27	RIGHT UNITS	01	20	30
28	UNITS/ CREDIT	01	05	05
29	UNITS/ BONUS	00	20	00
30	MINIMUM UNITS	00	00	00
31 - 58	Game-specific Play / Coinage Adjustments (detailed in text, the Game-specific Adjustments Setting Table and the Difficulty Setting Comparison Table)			
59 ⁵	INSTALL ADDABALL	NO		
60 ⁵	INSTALL 5-BALL	NO		
61 ⁵	INSTALL NOVELTY	NO		
62 ⁵	INSTALL EX. EASY	NO		
63 ⁵	INSTALL EASY	NO		
64 ⁵	INSTALL MEDIUM	NO		
65 ⁵	INSTALL HARD	NO		
66 ⁵	INSTALL EX. HARD	NO		
67	AUTO BURN-IN	NO		
68	CLEAR COINS	NO		
69	CLEAR AUDITS	NO		
70	INSTALL FACTORY	NO		

NOTES:

- Automatic Replay** percentage value range is adjustable from 5 to 25%, via the Credit Button. Item 02 permits changing the factory setting value for Replay Start Level (valid for next 50 games played). Item 03 permits setting up to four replay levels, with values as detailed in text describing Item 03. For **Fixed Replay Scores**, set Auto Replay value to 1 less than 5(%) via the Credit Button. Go to items 02, 03, 04, and 05; install their replay level scores. Turn off any replay level by setting 00 as its value.
- Phrase in parentheses is **Factory Setting**. Phrase appears in player displays. Press Credit Button to change setting of the game pricing of item 24.
- To change country OR coinage setting, press Credit button to obtain 24 Standard Settings, followed by a Custom Setting. The Custom Setting activates items 25 through 30. When a Standard Setting is used, items 25 through 30 are set automatically, and cannot be changed.
- Refer to **Pricing Table** and text describing these items.
- Special Preset Adjustment, whose effects are noted in the Game Adjustment text.
- Entries in Factory Setting columns for French and W. German games show only differences from entries in first (US / Can.) column.

POLICE FORCE GAME STATUS DISPLAYS (Continued)

One of the following **POLICE FORCE Game Difficulty Setting Tables** shows the five game 'difficulty' Adjustment Items (ranging from Ad 62 - Extra Easy through Ad 66 - Extra Hard) for the major models of pinball products (defined by country-language designations). Installing any one of these 'difficulty' Adjustments causes the values shown for each of the included game play Adjustment Items to be installed as a group, changing the level of play from one difficulty level to another. The owner/operator can use the information provided by the Audit Table items to determine whether the 'difficulty level' for this game in this location needs to change to obtain a higher level of earnings from the game or to provide a greater challenge to the location's players.

Once the 'difficulty level' is changed, a careful review of the Audit Items will reveal whether the change has achieved this higher-earnings goal. Sometimes, one (or more) of the Adjustment Items needs further change to keep the number of plays high, while still keeping the earnings level high. "Fine-tuning" of the game's Adjustment Items is a key feature of Williams Electronic Games products.

POLICE FORCE

Game Difficulty Setting Table for US / Canadian / French Games

Adj #	Adj Description	Extra Easy Ad 62	Easy Ad 63	Medium Ad (Factory) 64	Hard Ad 65	Extra Hard Ad 66
34	Jackpot Lit Timer	20 sec	18 sec	15 sec	10 sec	08 sec
35	Build Jackpot	18 sec	15 sec	10 sec	10 sec	10 sec
36	Game Over Unlock	No	No	Yes	Yes	Yes
37	Multi-Ball	Easiest	Easy	Easy	Hard	Hardest
38	Shots to Take Hi	2	2	2	2	3
39	Shots Till 1 Mill	3	5	6	7	8
40	Ex. Ball Memory	Yes	Yes	Yes	Yes	Yes
41	Police Memory	Yes	Yes	Yes	Yes	No
42	In Jail Memory	Yes	Yes	Yes	Yes	No
43	Memory Until ?X	6X	5X	4X	3X	2X
44	P-O-L-I-C-E/Ball	75%	75%	75%	50%	33%
45	Multi-Balls/Game	75%	66%	50%	33%	33%

NOTE

The 'difficulty' Factory Setting for French games is the equivalent of Ad 64 Medium, with 3 balls/game. German/European games also use the equivalent of Ad 64 Medium, with 3 balls/game.

POLICE FORCE

Game Difficulty Setting Table for German / European Games

Adj #	Adj Description	Extra Easy Ad 62	Easy Ad 63	Medium Ad (Factory) 64	Hard Ad 65	Extra Hard Ad 66
34	Jackpot Lit Timer	20 sec	18 sec	15 sec	10 sec	08 sec
35	Build Jackpot	18 sec	15 sec	10 sec	10 sec	10 sec
36	Game Over Unlock	No	No	Yes	Yes	Yes
37	Multi-Ball	Easiest	Easy	Easy	Hard	Hardest
38	Shots to Take Hi	2	2	2	2	3
39	Shots Till 1 Mill	3	5	6	7	8
40	Ex. Ball Memory	Yes	Yes	Yes	Yes	No
41	Police Memory	Yes	Yes	Yes	Yes	No
42	In Jail Memory	Yes	Yes	Yes	Yes	No
43	Memory Until ?X	6X	4X	3X	2X	2X
44	P-O-L-I-C-E/Ball	75%	75%	50%	33%	25%
45	Multi-Balls/Game	75%	50%	33%	25%	25%

GAME ADJUSTMENT PROCEDURE

Adjustment Items 01 through 70

The coin door must be open to access the Game Adjustment/Diagnostic switches. All readings and setting changes require operation of these coin door switches. Some setting changes utilize the Credit button; some also use the flipper button(s). *Additional text describing the game adjustment items follows this procedure; the value of the Factory Setting for each Game Adjustment item is in the preceding POLICE FORCE Game Adjustment Table.*

1. Use AUTO-UP and press ADVANCE. The Id 00 display initially appears. Press ADVANCE until the Player 3 display indicates **Ad 01**. If the factory setting has not changed, the upper Player Score display indicates AUTO REPLAY, and the lower display shows 10%, indicating a 10% replay percentage. (The game program adjusts itself automatically, as discussed in the following text concerning the 'details' about Adjustment Item 01.)
2. To reach a higher item number (in the lower display), use AUTO-UP and press ADVANCE. To return to a previous item number, use MANUAL-DOWN and press ADVANCE.
3. With the desired Game Adjustment Item number showing in the lower display, increase the setting value (or select another option) shown in the lower display by using AUTO-UP and pressing the Credit button. Repeat this step for each item, until all changes to the factory settings for the Game Adjustment Items have been made. The preceding Game Adjustment Table consolidates the Factory Settings into one grouping.

(The same procedure can be used for Audit Items. To zero **Au 01 - 04** (concerning the coin chutes and the total coins), the operator can proceed to item 68, Clear Coins, and press the Credit button to obtain the YES option. The operator then presses the ADVANCE button and notes the "DONE" display, which verifies that the entry values for items 01 through 04 of the Audit Items are now reset to zero.)

For example, the operator may desire to change the degree of game play difficulty from the Factory Setting (equivalent to the Install Medium [Ad 64] difficulty, along with a number of other automatically installed settings, as shown in the right column of the Game Adjustment Table) to another difficulty more suitable for the players at a particular game site. Four other 'automatic' play difficulty settings (Ad 62 - Ad 66) are available, each of which, if selected, installs all the adjustments listed for that difficulty in the Game Adjustment Setting Comparison Table, which precedes the 'details' text.

4. To proceed rapidly through the entire adjustments series, *press and hold* ADVANCE, until **Ad 70** shows in the lower display. From item 70, you can: (A) return to the Game-Over Mode; or (B) restore factory settings and zero audit (bookkeeping) totals. Perform either of the following, as desired:
 - A. To reach Game-Over Mode, use AUTO-UP and press ADVANCE once. **POLICE FORCE** now goes to the Game-Over Mode.
 - B. To restore the Factory Settings for Game Adjustment Items (as listed in the Game Adjustments Table), zero all audit (bookkeeping) totals, and return to Game-Over Mode, use AUTO-UP or MANUAL-DOWN to display Ad 70 in the lower display. Press the Credit button to display the YES option in the lower display. Using AUTO-UP, press ADVANCE once. **POLICE FORCE** now zeroes ALL Audit Item totals and changes ALL Game Adjustment Items back to those originally selected as Factory Settings. It then shows the operator a message ("FACTORY SETTING") that this has occurred. (A problem in the Memory Protection circuit or closing the coin door will cause the message "ADJUST FAILURE" to appear.) Press ADVANCE once more to return to the Game-Over Mode.

GAME ADJUSTMENT PROCEDURE (Continued)

Details of Adjustment Items 01 through 70

01 Auto Replay (or Fixed Replay)

Of the two options, AUTO REPLAY is the percentage of replays automatically awarded per game. The game program aids a pinball's initial installation by causing a comparison of the value of the Replay Level to the value of all players' scores every 50 games. At each comparison, the program increases (or decreases) the Replay Level by an amount necessary to achieve the replay percentage specified either via the factory setting or later operator selection. Use the Credit button to change the percentage within the range of 5 to 25 (%), with the value increasing using AUTO-UP (or decreasing using MANUAL-DOWN). The next Credit button change below 5%, selects the FIXED REPLAY option.

For AUTO REPLAY, Ad 02 provides the Starting Replay Level (the upper display shows REPLAY START). Ad 03 provides the number of replay levels (01, 02, 03, or 04). POLICE FORCE then proceeds to Ad 06 automatically.

For FIXED REPLAY, Ad 02 is the first replay level (REPLAY LEVEL 1). Ad 03, 04, and 05 are the other replay levels.

02 Starting Replay Level (or Replay Level 1)

For AUTO REPLAY (refer to Ad 01), the initial Factory Setting is listed in the Game Adjustment Table. The range of settings is 800,000 through 9,800,000 (by increments of 100,000 with AUTO-UP or decrements of 100,000 with MANUAL-DOWN).

For FIXED REPLAY, the operator can enter the value to be used for the first fixed replay score level via the Credit button. The range of settings is: OFF; 100,000 through 9,900,000 (by increments of 100,000 with AUTO-UP, or decrements of 100,000 with MANUAL-DOWN).

03 Replay Levels (or Replay Level 2)

For AUTO REPLAY (refer to Ad 01), this is the number of replay levels in a game. The option range is one, two, three, or four replay level(s). When the operator chooses two replay levels, POLICE FORCE automatically adjusts the second replay level to be twice the value selected for Ad 02, the starting replay level. Choosing three or four replay levels automatically adjusts their replay levels to three times or four times the Ad 02 value.

For FIXED REPLAY, the technique of value entry and the range of settings are identical to those of Ad 02.

04 (Replay Level 3)

For AUTO REPLAY, this Adjustment Item is not applicable. POLICE FORCE automatically bypasses this adjustment.

For FIXED REPLAY, the technique of value entry and the range of settings are identical to those of Ad 02.

05 (Replay Level 4)

For AUTO REPLAY, this Adjustment Item is not applicable. POLICE FORCE automatically bypasses this adjustment.

For FIXED REPLAY, the technique of value entry and the range of settings are identical to those of Ad 02.

GAME ADJUSTMENT PROCEDURE (Continued)

06 Replay Award

For either AUTO REPLAY or FIXED REPLAY (Ad 01), the operator can select the form of the award automatically provided when the player exceeds any Replay Level (Automatic or Fixed). The choices are:

- Credit* - Reaching each replay level obtains a credit (free game).
- Ball* - Reaching each replay level obtains an extra ball.
- Audit* - Reaching each replay level obtains nothing to the player; it does increase the entry value of the Audit Item(s) maintaining a tally of these awards (Au 08, and Au 20 through 23, as applicable).

07 Special Award

The operator can select the form of the award automatically provided when the player scores a Special. The choices are:

- Credit* - Scoring each Special, when lit, obtains a credit (free game).
- Ball* - Scoring each Special, when lit, obtains an extra ball.
- Score* - Scoring each Special, when lit, obtains a score advance of 100,000 points to the player.

08 Match Award

The operator can select (via the Credit button) the desired percentage for the Match action occurring at the completion of each game. The choices are:

- 1%-50%* - 1% is 'hard'; 50% is 'extremely easy'. During Match action, the game selects a random two-digit number at end of game and compares each player's score for an identical two digits in the rightmost two positions. A matching of the two digits results in the award of a credit.
- Off* - The MATCH display does not operate at completion of the game; no award is given.

09 Balls / Game

The operator can define a "game" by specifying the number of balls to be played. The range of this setting is 1 through 9.

10 Tilt Warning

The operator can specify the number of total actuations of the plumb bob mechanism that can occur before the game is "tilted". The range of this setting is 1 through 5.

11 Extra Ball/Ball In Play

The operator can choose (via the Credit button) the number of Extra Balls to be awarded to a player. The range of this setting is:

- 00* - NO extra ball play; displays a message, NO EX. BALL.
- 1-9 E. B./Ball* - 1 through 9 Extra Balls per ball (i.e., all balls including Extra Balls) are awarded.
- 1-9 E. B./B.I. P.* - 1 through 9 Extra Balls per Ball In Play (B. I. P.) (i.e., all balls NOT including Extra Balls) are awarded.
- 1-9 E. B./Game* - 1 through 9 Extra Balls per game.

12 Maximum Credits

The operator can specify the maximum number of credits the game can accumulate, either through game play awards or coin purchases. The range of settings is 5 through 10. Reaching the specified setting prevents the award of any credits.

GAME ADJUSTMENT PROCEDURE (Continued)

13 Highest Scores

The operator can specify (via the Credit button) whether the game is to maintain a record of the four highest scores achieved to date. The choices are:

Off - NO high scores are recorded.

On - The four highest scores are stored in memory for use by Game Adjustment 22.

14 Backup High Score 1

The operator can set the Backup High Score value in the upper display (for Player 1), using the Credit button. The game automatically restores this value, when the operator presses, and holds, the HIGH SCORE RESET switch, or when an automatic High Score Reset event (Ad 22) occurs.

15 Backup High Score 2

This adjustment is similar to Ad 14, except that this applies to the Player 2 Score display. The adjustment technique is identical to Ad 14. It is also restored as described for Ad 14.

16 Backup High Score 3

This adjustment is similar to Ad 14, except that this applies to the Player 3 Score display. The adjustment technique is identical to Ad 14. It is also restored as described for Ad 14.

17 Backup High Score 4

This adjustment is similar to Ad 14, except that this applies to the Player 4 Score display. The adjustment technique is identical to Ad 14. It is also restored as described for Ad 14.

18 Credits for Highest Score 1

The operator can select the number of credits to be awarded, by using the Credit button, whenever a player exceeds the previous Highest Score. The range of this setting is 00 through 10.

19 Credits for Highest Score 2

This adjustment is similar to Ad 18, except that this applies to the player's exceeding the second highest score. The Credit button adjustment technique is the same as for Ad 18. The range of this setting is 00 through 03.

20 Credits for Highest Score 3

This adjustment is similar to Ad 18, except that this applies to the player's exceeding the third highest score. The Credit button adjustment technique is the same as for Ad 18. The range of this setting is 00 through 03.

21 Credits for Highest Score 4

This adjustment is similar to Ad 18, except that this applies to the player's exceeding the fourth highest score. The Credit button adjustment technique is the same as for Ad 18. The range of this setting is 00 through 03.

22 Automatic High Score Reset

The operator can specify (via Credit button) that the game will provide an automatic reset of the displayed "Highest Scores", and the number of games to be played before the reset occurs. (Audit item 39 displays the games remaining before the reset.) The values provided upon reset are those selected by the operator in Ad 14 through 17, the Backup High Scores. The range of this setting is *Off* (to disable this adjustment), and 250 to 24,750 games (in increments of 250).

23 Free Play

The operator can select (via the Credit button) whether a player can operate the game without a coin (free play) or with a coin. The choices are:

No - A coin is necessary for game play.

Yes - Game play is free; no coin is required.

GAME ADJUSTMENT PROCEDURE (Continued)

24 Coinage Selections

The operator can specify (via the Credit button) any of the 23 Standard Settings for game pricing, each of which exhibits a message identifying the country and the number of coins required and the number of games that the coin requirement purchases. Choosing a Standard Setting permits the game to omit Items Ad 25 through 30, which are adjustments allowing for a special custom coinage setting.

Following the last Standard Setting is a Custom Coinage Setting, which allows the operator to utilize Ad 25 through 30 in establishing a special coinage setting. A message, CUSTOM COINAGE, indicates that the operator can enter the appropriate values into the Ad 25 through 30 adjustment items.

The values for Ad 25 through 30 of each Standard Setting, as well as other possible values for the Custom Coinage Setting are shown in the **Pricing Table**.

25 Left Chute Coin Units

The operator can specify (via the Credit button) the number of coin units purchased by a coin passing through the left coin chute.

26 Center Chute Coin Units

The operator can specify (via the Credit button) the number of coin units purchased by a coin passing through the center coin chute.

27 Right Chute Coin Units

The operator can specify (via the Credit button) the number of coin units purchased by a coin passing through the right coin chute.

28 Units Required for Credit

The operator can define (via the Credit button) the number of coin units required to obtain 1 Credit. A coin unit counter in the game program totals the number of coin units purchased through all coin chutes prior to each game. If the total of these coin units matches, or exceeds, the Units per Credit value by a multiple (or more, coin units) of the specified Units per Credit value, the Credits display shows the proper number of Credits. The coin unit counter retains any remaining coin units, until the start of a game; then, the coin unit counter is cleared (its contents are zeroed).

29 Units Required for Bonus

The operator can specify (via the Credit button) that 1 additional Credit is to be indicated in the Credits display, when a certain number of coin units are accumulated.

30 Minimum Units Required for any Credits Posted

The operator can specify that NO Credits are to be posted (indicated in the Credits display), until the credit units counter reaches a particular value, by setting this value to 02 (or more). A setting of 01 allows the Credits display to show fractional coin units.

The System 11B game program defines the following 28 Adjustment Items as "game-specific"; that is, they are unique for each game. The Game Designer/Engineer/Programmer team members work together to use these as controlling factors for game play. By varying the setting of these Adjustment Items, it is possible to "fine-tune" a game to suit a particular location, enabling the owner/operator to reap maximum earnings, while still providing the players with sufficient challenge to keep them playing.

GAME ADJUSTMENT PROCEDURE (Continued)

31 1/2 PRICE BUY IN

The operator can choose (via the Credit button) whether the player is allowed to 'buy-in' subsequent games at 1/2 price. The number of games offered at 1/2 price is determined by the number of players in the previous game; that is, if the previous game had 3 players, 3 credits can be purchased for 1/2 price. Note: This requires that the left coin slot is always the smallest denomination of coin. When these conditions exist, the choices for Ad 31 are:

Yes - The player has 10 seconds to 'buy in' the next game(s) at 1/2 the original cost.

No - The 'buy in' is NOT available.

32 PROGRESSIVE / NORMAL / CONTEST GAME

The operator can specify (via the Credit button) whether the progressive features of **POLICE FORCE** are allowed to carry over to the next game. When the game is set for 'contest' (tournament) play, single-player games are identical from game to game (no features carry over). This disables all automatic percentaging and fixes the JACKPOT value at its maximum. The choices are:

Contest Game - The game is set for use in a contest or tournament.

Progressive Game - Progressive ("build-up") features of the game carry over to the next FREE game only, and the JACKPOT increases normally.

Normal Game - No features carry over to the next game, and the JACKPOT increases normally.

33 LIBERALIZER

The operator can choose (via the Credit button) whether the Hotsheet feature of the game becomes more liberal after 8,000 games. The choices are:

Yes - (Liberal) The Liberalizer feature becomes effective after 8,000 games.

No - (Conservative) The Liberalizer feature is NOT available.

34 JACKPOT LIT TIMER

The operator can choose (via the Credit button) the Time Limit for lighting the JACKPOT feature lamp. The JACKPOT lamp is lighted (feature enabled) by jailing all four criminals; to collect the JACKPOT requires a shot up the Right Ramp before the time limit elapses. The range of this setting is 4 *seconds* (Conservative) through 99 *seconds* (Liberal).

35 BUILD JACKPOT

The operator can specify (via the Credit button) the Time Limit for increasing the JACKPOT value. After the player spells G-U-N, the Jackpot value increases with each target hit during the specified time limit. The range of this setting is 4 *seconds* (Conservative) through 99 *seconds* (Liberal).

36 GAME OVER UNLOCK

The operator can choose (via the Credit button) whether the game saves any 'locked' balls at game end (to make Multi-Ball™ play easier during the next game). The choices are:

Yes - (Conservative) Do NOT save any locked balls at game end.

No - (Liberal) Save all locked balls at game end for 'next-game' play.

GAME ADJUSTMENT PROCEDURE (Continued)

37 MULTI-BALL™

The operator can choose (via the Credit button) the difficulty for obtaining Multi-Ball™ play. The choices are:

Easiest - (Liberal) All locks are free.

Easy - Before Multi-Ball, all locks are free. After first Multi-Ball play, one criminal must be jailed to allow ball lock to start.

Hard - Before Multi-Ball, all locks are free. After first Multi-Ball play, one criminal must be jailed to allow each ball to be locked.

Hardest - (Conservative) Before locking any ball, one criminal must be jailed.

38 SHOTS TO TAKE HI

The operator can choose (via the Credit button) how many consecutive Right Ramp shots are required to obtain the "Take Highest Score" feature. This feature is made available on each player's last ball. The range of settings are 2 (Liberal) through 8 (Conservative) shots.

39 SHOTS TILL 1 MILL

The operator can choose (via the Credit button) how many consecutive Right Ramp shots are required to start the "UNLIMITED MILLION" feature. After awarding 1 Million points, the game requires EIGHT shots to restart this feature. The range of settings are 2 (Liberal) through 8 (Conservative) shots.

40 EX. BALL MEMORY

The operator can choose (via the Credit button) whether the five Extra Ball lamps are carried over for 'next-ball' play. The choices are:

Yes - (Liberal) Lighted Extra Ball lamps are stored in memory.

No - (Conservative) Any lighted Extra Ball lamps are turned off at the end of each ball.

41 POLICE MEMORY

The operator can choose (via the Credit button) whether the lighted P-O-L-I-C-E lamps are stored in memory for recall during 'next-ball' play. The choices are:

Yes - (Liberal) Any lit P-O-L-I-C-E lamps are stored in memory for recall during the player's next ball.

No - (Conservative) Lamps are Off at the end of each ball.

42 IN JAIL MEMORY

The operator can choose (via the Credit button) whether 'jailed' (lamps lighted) criminals stay in jail (are stored in memory) for 'next ball' play. NOTE: The setting affects the award of the JACKPOT. The choices are:

Yes - (Liberal) Any lit criminal lamps are stored in memory for recall during player's next ball.

No - (Conservative) Lamps are Off at the start of each ball.

43 MEMORY UNTIL ? X

The operator can choose (via the Credit button) when the Bonus Multiplier lamps are turned off. NOTE: The setting affects the Special award. The range of this setting is 2X (Conservative) through 6X (Liberal).

GAME ADJUSTMENT PROCEDURE (Continued)

44 P-O-L-I-C-E / BALL

The operator can choose (via the Credit button) how often the Hotsheet feature will attempt to award (spot a letter) in P-O-L-I-C-E. As a percentage factor, it is the number of times a letter was lit times 100, divided by the number of balls played. NOTE: This affects the TOP COP Bonus; however, progressively fewer lamps will be lighted, based upon the number already lit. The range of this adjustment setting is *Enabled 1% (Conservative)* through *99% (Extremely Liberal)*. This adjustment can also be turned off, via a setting of *0 (Off)*.

45 MULTI-BALLS™ / GAME

The operator can choose (via the Credit button) how often the Hotsheet feature will attempt to start Multi-Ball play, with the requirement that 1 ball is already locked. As a percentage factor, it is the number of times a letter was lit times 100, divided by the number of games played. NOTE: This affects the TOP COP Bonus because, during Multi-Ball, it is easier to light the letters of P-O-L-I-C-E. The range of this adjustment setting is *Enabled 1% (Conservative)* through *99% (Extremely Liberal)*. This adjustment can also be turned off, via a setting of *0 (Off)*.

46 EX. BALLS / GAME

The operator can choose (via the Credit button) the MINIMUM value of ALL Extra Balls awarded per game. This adjustment controls how many Extra Balls are awarded by the Hotsheet feature. The range of this adjustment setting is *Enabled 1% (Conservative)* through *99% (Extremely Liberal)*. This adjustment can also be turned off, via a setting of *0 (Off)*.

47 SPECIALS / GAME

The operator can choose (via the Credit button) the MINIMUM AMOUNT OF ALL Specials awarded during a single game. This adjustment controls how many Specials are awarded by the Hotsheet feature. The range of this adjustment setting is *Enabled 1% (Conservative)* through *99% (Extremely Liberal)*. This adjustment can also be turned off, via a setting of *0 (Off)*.

48 ATTRACT MODE SOUNDS

The operator can choose (via the Credit button) the amount of sounds to be heard during the Attract Mode. The choices are:

ALOT - Sounds are heard continuously during Attract Mode.

LESS - Sounds are heard for 15 minutes after the end of a game, during Attract Mode.

NONE - No sounds are heard during Attract Mode.

49 Custom Message

The operator can choose (via the Credit button) whether to display a message during the Attract Mode. (When display of a message is selected, the operator can either utilize the message provided or change the message.) Three choices are available:

- 1 - Display a message during the Attract Mode. The lower display shows this choice as ON. The 3-line message provided is:

BE TOP COP ... PLAY ... POLICE FORCE.

- 2 - Do NOT display a message during the Attract Mode. (Lower display shows OFF.)

- 3 - The lower display shows this choice as CHANGE. The operator can enter a special ("custom") message, as follows:

- A. Press ADVANCE once. The operator can now enter as many as three 14-character lines for display during the Attract Mode.

- B. Use the flipper button(s) to select each message character (alphabet, numbers, and special symbols are available). In case of error, enter a "back arrow" (just before "space") to correct, followed by correct character. For a period after any letter, use letters with periods (following the special symbols). The entire character set is the following:

A B C D E F G H I J K L M N O P Q R S T U V W X Y Z 0 1 2 3 4 5 6 7 8 9 < > ? - / * ' .

A . B . C . D . E . F . G . H . I . J . K . L . M . N . O . P . Q . R . S . T . U . V . W . X . Y . Z . _

- C. Move to the next character via the Credit button. The game program does not allow entirely blank lines to be displayed.

GAME ADJUSTMENT PROCEDURE (Continued)

50 DISPLAY AU 01 - 04

The operator can choose (via the Credit button) how to display the coinage audit information, Au 01 - 04. No information is lost; it remains stored in the CPU memory. The information is now available for readout via the player score displays. Three choices are available:

- Yes - Both the audit text (slot identification) and the value is displayed.
- Nbr - Only the numerical value is displayed.
- No - NO display occurs.

51 CONSOL. BALL TIME

The operator can choose (via the Credit button) the desired ball time for a game. On the last ball, if a player has not reached this 'game time' period, a form of consolation play becomes effective to encourage players to continue playing. For **POLICE FORCE**, the calculation involves determining at ball start for the last ball whether at least 2/3 of the 'desired game time' has elapsed. If not, the Extra Ball lamp of the left Drain Lane will turn on to allow the player a chance to obtain an Extra Ball. The range of this setting is *Off* (Extra Ball lamp is not lit, because there is no minimum game time limit); *1 second* (Conservative) through *99 seconds* (Liberal). NOTE: Consolation Extra Balls are NOT audited as Extra Balls.

52 NORMAL / DIM / DIMMEST FLASHERS

The operator can choose (via the Credit button) the brightness of the game's flashlamps. A suggestion is to use either DIM or DIMMEST when the power supplied to the game is in the 'High Power' (over 120V ac for domestic game and over 230V ac for foreign games). The range of this setting is *Normal*, *Dim*, *Dimmest*.

53 - 58 Special Preset Adjustment Settings

SPECIAL PRESET ADJUSTMENTS CAUTION

Adjustments 53 through 66 are Special Preset Adjustments to enable the operator to perform the setting of multiple adjustments at once. They permit the operator to: (1) modify the game for a specific area (for example, coinage settings for a country); (2) change a group of adjustments to conform with laws of certain localities; and (3) change the degree of difficulty of game play (Ad 62 through 66). Whenever the operator chooses to use any Special Preset Adjustment, the operator can later access any or all of the individual Adjustments affected by that Special Adjustment for subsequent changes.

A similar technique is recommended in the event of error or uncertainty concerning any Special Preset Adjustment, after the operator selects it: The operator can restore the factory setting of each individual Adjustment, then select the desired Special Preset Adjustment, and then return to any of the preceding individual adjustments to determine whether use of the Special Adjustment has had the desired effect.

The Backbox displays for each Special Preset Adjustment indicate whether the operator has selected it, by identifying the Adjustment in the upper displays by name and the selection choice of NO, meaning Not Selected (this is the Factory Setting), or YES, meaning Selected, in the lower display. Operator installation of the 'selected' Preset Adjustment occurs by using the Credit button to choose YES and then pressing the ADVANCE switch. The displays then show the name of the Adjustment again, with DONE to show that the installation is now in effect.

Note that, when an operator installs any of the Special Preset Adjustments, Adjustment Items using the automatic adjust feature of the game program reset to the INITIAL auto adjust value listed for that Adjustment Item.

NOTE

A game in which the CPU has ROMs installed for German (Deutsch) or French (Francais) language and play adjustments automatically has certain Adjustment Items preset. The following tables show these Preset Adjustment Items for each of the special language games.

GAME ADJUSTMENT PROCEDURE (Continued)

- 53 through 58 For German/European Games Only:** Install German 1, 2, 3, 4, 5 or 6
The operator can use these Adjustment Items to modify the game pricing selection of Standard Setting named "German 2 or German 1" in the **Pricing Table** to permit the style of play for the particular price shown in the **POLICE FORCE Preset Game Adjustments Table for German/European Games**.

POLICE FORCE
Preset Game Adjustments Table for German/European Games

Adj #	Adj Description	German Ad 1 53	German Ad 2 54	German Ad 3 55	German Ad 4 56	German Ad 5 57	German Ad 6 58
06	Replay Award	Credit	Coil	Audit	Credit	Coil	Audit
07	Special Award	Credit	Ball	Score	Credit	Ball	Score
08	Match Feature	10 %	10 %	Off	10 %	10 %	Off
09	Match Feature	10 %	10 %	Off	10 %	10 %	Off
14	Backup High Score 1	7,000,000	7,000,000	00	7,000,000	7,000,000	00
15	Backup High Score 2	6,500,000	6,500,000	00	6,500,000	6,500,000	00
16	Backup High Score 3	6,000,000	6,000,000	00	6,000,000	6,000,000	00
17	Backup High Score 4	5,500,000	5,500,000	00	5,500,000	5,500,000	00
18	High Score 1 Credits	03	03	00	03	03	00
19	High Score 2 Credits	00	00	00	00	00	00
20	High Score 3 Credits	00	00	00	00	00	00
21	High Score 4 Credits	00	00	00	00	00	00
24	Coinage Setting	6 spiele/5 DM	6 spiele/5 DM	6 spiele/5 DM	7 spiele/5 DM	7 spiele/5 DM	7 spiele/5 DM

- 53 through 57 For French Games Only:** Install French 1, 2, 3, 4, or 5
The operator can use these Adjustment Items to modify the style of play for the particular setting shown in the **POLICE FORCE Preset Game Adjustments Table for French Games**. NOTE: No preset Game Adjustment is applicable for Ad 58.

POLICE FORCE
Preset Game Adjustments Table for French Games

Adj #	Adj Description	French Ad 1 53	French Ad 2 54	French Ad 3 55	French Ad 4 56	French Ad 5 57
46	Extra Ball / Game	25%	20%	33%	25%	25%
51	Consol. Ball Time	50 sec	40 sec	70 sec	50 sec	50 sec

- 53 ADVERTISEMENT? (For USA / Canadian Games only)**
The operator can choose (via the Credit button) whether to display an advertisement provided by the manufacturer. The choices are:

- Yes - Display the advertisement message.
- No - Do NOT display the message.

- 54 through 58 (For USA / Canadian Games only)**
The operator can use these Adjustment Items to modify the game pricing selection and select either the 3-ball or 5-ball style of play.

GAME ADJUSTMENT PROCEDURE (Continued)

POLICE FORCE

Preset Game Adjustments Table for US / Canadian Games

Adj #	Adj Description	1 Coin Buy-in	Ad 54	Install 3 Ball	Ad 55	3 Balls/ 2 Coins	Ad 56	3 Balls/ 1 Coin	Ad 57	5 Balls/ 2 Coins	Ad 58
02	Replay Start	-		3,500,000		3,500,000		3,500,000		5,000,000	
09	Balls / Game	-		3		3		3		5	
14	Backup High Score 1	-		5,000,000		5,000,000		5,000,000		6,000,000	
15	Backup High Score 2	-		4,500,000		4,500,000		4,500,000		5,500,000	
16	Backup High Score 3	-		4,000,000		4,000,000		4,000,000		4,000,000	
17	Backup High Score 4	-		3,500,000		3,500,000		3,500,000		3,500,000	
24	Coinage Setting	USA 3		-		USA 2		USA 1		USA 2	
31	Half Price Buyin	Yes		No		No		No		No	
64	Install Medium	No		Yes		Yes		Yes		No	
65	Install Hard	No		No		No		No		Yes	

- 59 Install Add-A-Ball** The operator can utilize this option to delete all Free Play awards and replace them with Extra Ball awards. Individual Adjustments are affected, as follows:

Ad Name	New Setting	Ad Name	New Setting
06 Replay Award	Ball	18 Hi Scr 1 Credits	00
07 Special Award	Ball	19 Hi Scr 2 Credits	00
08 Match Feature	Off	20 Hi Scr 3 Credits	00
11 Ex. Ball	4/BIP	21 Hi Scr 4 Credits	00

60 Install 5 Ball

The operator can change the game to 5-ball play, including the changing of certain features to the recommended 5-ball difficulty level. NOTE: Ad 65 (Install HARD) settings are also set when the game is changed to '5-ball Play'. Other Adjustments are affected, as follows:

Ad Name	New Setting	Ad Name	New Setting
02 Replay Start	5,000,000	09 Balls / Game	05

61 Install Novelty

The operator can remove all Free Play and Extra Ball awards. Individual Adjustments are affected, as follows:

Ad Name	New Setting	Ad Name	New Setting
01 Fixed Replay	SCORES	07 Special Award	Score
02 Replay Level 1	Off	08 Match Feature	Off
03 Replay Level 2	Off	11 No Extra Ball	00
04 Replay Level 3	Off	18 Hi Scr 1 Credits	00
05 Replay Level 4	Off	19 Hi Scr 2 Credits	00
06 Replay Award	Audit	20 Hi Scr 3 Credits	00
		21 Hi Scr 4 Credits	00

62 Install Extra Easy

The operator can change the game play difficulty adjustments to a combination that is extremely easy (sometimes called "liberal"). The Game Difficulty Setting Table, which precedes these 70 individual Adjustments descriptions, lists the Adjustments and the settings that comprise the 'Extra Easy' group.

63 Install Easy

The operator can change the game play difficulty adjustments to a combination that is slightly easier than the Factory Settings. The Game Difficulty Setting Table, which precedes these 70 individual Adjustments descriptions, lists the Adjustments and the settings that comprise the 'Easy' group.

GAME ADJUSTMENT PROCEDURE (Continued)

64 Install Medium

The operator can change the game play difficulty adjustments to a combination that matches the Factory Settings. The Game Difficulty Setting Table, which precedes these 70 individual Adjustments descriptions, lists the Adjustments and the settings that comprise the 'Medium' group.

65 Install Hard

The operator can change the game play difficulty adjustments to a combination that is more difficult than the Factory Settings. The Game Difficulty Setting Table, which precedes these 70 individual Adjustments descriptions, lists the Adjustments and the settings that comprise the 'Hard' group.

66 Install Extra Hard

The operator can change the game play difficulty adjustments to a combination that is much more difficult than the Factory Settings. The Game Difficulty Setting Table, which precedes these 70 individual Adjustments descriptions, lists the Adjustments and the settings that comprise the 'Extra Hard' group.

67 Auto Burn-In

The operator can choose the YES option for this Special Preset Adjustment to perform certain automatic testing of the game, as used in the factory. It does not affect the game operation, but merely provides for a cyclic testing of most of the game's mechanisms.

68 Clear Coins

The operator can request the clearing of the coinage audits (Au 01 through 04) by selecting (via the Credit button) the YES option, as shown in the lower display. This adjustment zeroes the counters tallying the number of coins through each slot, the Paid Credits counter, and the Credits display. After the YES option is displayed, the operator must press the ADVANCE button. The game then displays DONE to show that the coinage audits were reset to zero.

69 Clear Audits

The operator can request the clearing of the non-coinage audits (Au 05 through 55) by selecting (via the Credit button) the YES option, as shown in the lower display. This Adjustment zeroes the counters tallying the remaining Audit factors. Please note that this does NOT affect the Automatic Replay Percentaging data nor the automatic High Score Reset counter. After the YES option is displayed, the operator must press the ADVANCE button. The game then displays DONE to show that the non-coinage audits were reset to zero.

70 Install Factory

The operator can request the game (via the Credit button) to provide the normal Factory Settings, essentially restoring the game to its 'factory condition'. The operator must select the 'YES' option for this adjustment. This Adjustment clears all Audits, resets all Game Adjustments to the respective Factory Settings, and provides a restart of the Auto Replay (Ad 01). After selecting the YES option, the operator must press the ADVANCE button. The game then displays FACTORY SETTING.

Closing of the coin door before appearance of the FACTORY SETTING message or a problem in the Memory Protect circuit will cause the game to display ADJUST FAILURE. A loss of battery power or improper treatment of the Game Adjustments will cause the game to attempt to restore Factory Settings. The game announces the results of this reset process with the appropriate message, FACTORY SETTING or ADJUST FAILURE.

GAME ADJUSTMENT PROCEDURE (Continued)

RESETTING THE HIGH SCORES

The challenge of exceeding the High Score (either the factory setting or a higher score by another player) is the goal of many pinball game players. To keep a pinball game challenging requires a method of resetting the High Score value for those occasions when a skilled player registers a truly excellent score. Other players note this score and may decide not to play simply because their skill is not adequate to exceed an extremely high score.

For **POLICE FORCE**, in fact, three methods of resetting the High Score values are available. The simplest method involves allowing Game Adjustment Item Ad 22 to reset the High Score values automatically after the specified number of plays designated by the operator. The second method requires pressing the High Score Reset switch on the inside of the coin door in the Attract Mode. This action simply erases the previous high score values and replaces them with the Backup High Score values. The third method establishes new values replacing the factory setting values or previous operator setting values; it requires performing the following steps:

1. Using AUTO-UP or MANUAL-DOWN, reach item Ad 14 (and items Ad 15, 16, and 17, if desired). The High Score value of the factory setting (or previous operator-adjusted setting) appears in the upper display. If this value is satisfactory, go to step 4 below.
2. If you wish to increase the High Score value from that displayed in the upper display, use AUTO-UP, and press the Credit button, until the desired value shows in the upper display.
3. If you wish to decrease the High Score value, use MANUAL-DOWN, and press the Credit button, until the desired value shows in the upper display.
4. Using AUTO-UP, press and hold down ADVANCE, until the lower display shows Ad 70. Press ADVANCE once, to return to Game-Over Mode.
5. Press the High Score Reset switch (on coin door), and listen for the sound signifying that the score reset action is complete. Observe player score displays to verify that the new High Score values are displayed.

GAME PRICING

PRICING MADE EASY. Game Adjustment Item Ad 24 allows the operator an easy method of setting the pricing functions. Pressing the Credit button allows the operator a choice of one of the 16 "Standard" Settings, with associated automatic pricing (the upper display shows the Country identifier, with a number for a country having more than one "Standard" Setting; the lower displays show the games per coin(s) information). In the *Pricing Table*, each "Standard" Setting is denoted by a Country Identifier. Automatic Pricing causes each of the other pricing items (columns 25 through 30) to change to the value shown in the table for that selected "Standard" Setting. In the table where the word "CUSTOM" appears, the owner/operator must enter the values shown (columns 25 through 30) to obtain the games per coin factor shown in the Games/Coin column of the table. To make these setting adjustments, the owner/operator must press the Credit button until the words "CUSTOM COINAGE" appear in the player score displays.

CUSTOM PRICING. Adjustment Item 24 must be set to the Custom Coinage Setting (upper display showing CUSTOM COINAGE) to enable the operator to enter desired custom pricing selections for Items 25 through 30, based on the *Pricing Table*. Item 25 is the left coin chute multiplier. Item 26 is the center coin chute multiplier. Item 27 is the right coin chute multiplier. Item 28 is the number of coin units equal to one Credit. (A Credit is usually equal to one game.)

The calculation of the ratio of Games : Price uses the ratio equation of $X : VC$, where:

X = Coin Chute Multiplier (Item 25, 26, or 27 in *Pricing Table*);

V = Value of coin;

C = Coin units equivalent to one Credit (Item 28).

For example, for 25¢ chutes at the factory setting, substituting values in the Games : Price ratio calculation gives $1 : 25 \times 1$, or one game for 25¢.

UNITS REQUIRED FOR BONUS CREDIT. Item 29 is the number of coin units that must pass through the coin chute(s) before an additional Credit (game) is posted (displayed). At the factory setting, the number in this item is 00. (This 00 means that NO bonus credit (free game) is awarded, although purchase of more than one game at a time occurs.)

MINIMUM COIN UNITS. Item 30 determines the number of coin units that must pass through the coin chute(s) before play may begin. The Factory Setting for this item is 00. (This 00 means that the Minimum Coin Units feature (Item 30) is disabled; a 01 setting also means that this feature is still disabled, yet the Credits message display should display fractional coin units.)

POLICE FORCE Pricing Table

Country	Coin Chute			Games/Coin	Ad 24 Display	Pricing Functions					
	Left	Center	Right			25	26	27	28	29	30
USA and Canada	25¢	-	25¢	1/25¢, 4/\$1 ^{1, 2}	U.S.A. 1	01	04	01	01	00	00
				1/50¢, 2/75¢, 3/\$1 ²	U.S.A. 2	03	12	03	04	00	00
				1/50¢, 2/\$1 ²	U.S.A. 3	01	04	01	02	00	01
				1/25¢, 3/\$1 ²	U.S.A. 4	01	00	01	02	04	01
				1/25¢, 3/50¢, 6/\$1	CUSTOM	01	04	01	01	02	00
				1/25¢, 5/\$1	CUSTOM	01	00	01	01	04	00
				1/50¢ ; Add'l game: 25¢	CUSTOM	98	00	98	99	00	00
Austria	5 Sch	10 Sch	10 Sch	1/2x5 Sch, 3/2x10 Sch ²	AUSTRIA	01	02	02	02	04	01
				2/5 Sch, 5/10 Schilling	CUSTOM	02	00	05	01	00	00
				2/5x1 Sch, 2/5 Sch, 5/10 Sch	CUSTOM	02	10	25	05	00	00
Australia	20¢	-	\$1	1/3x20¢, 2/\$1 ²	AUSTRAL	02	00	10	05	00	00
United Kingdom	10 P	50 P	1£	1/2x10 P, 3/50 P, 7/1£ ²	U.K.	03	15	30	05	30	00
				1/10 P, 5/50 P, 2/20 Pence	CUSTOM	03	15	30	05	30	00
Switzerland	1 F	2 F	5 F	1/1 F, 3/2 F, 7/5 Franc ²	SWISS	01	03	07	01	00	00
				1/1 F, 3/2 F	CUSTOM	03	00	06	02	00	00

GAME PRICING (Continued)

POLICE FORCE Pricing Table (Continued)

Country	Coin Chute			Games/Coin	Ad 24 Display	Pricing Functions					
	Left	Center	Right			25	26	27	28	29	30
Belgium	20 F	20 F	20 F	3/20 Franc ²	BELGIUM	03	03	03	01	00	00
	5 F	-	20 F	1/2x5 F, 2/20 Franc	CUSTOM	01	00	04	02	00	01
	5 F	20 F	20 F	1/2x5 F, 2/20 F, 2/20 F	CUSTOM	01	04	04	02	00	01
	5 F	5 F	20 F	1/2X5 F, 1/2X5 F, 2/20 F	CUSTOM	01	01	04	02	00	01
West Germany	1 DM	2 DM	5 DM	1/1 DM, 2/2 DM, 7/5 DMark ^{2,3}	GERMAN1	06	12	30	05	30	00
				1/1 DM, 2/2 DM, 6/5 DM ^{1,2}	GERMAN2	06	12	30	05	00	00
				1/1 DM, 3/2 DM, 9/5 DM	CUSTOM	09	18	45	05	00	00
				1/2x1 DM, 1/2 DM, 3/5 DM	CUSTOM	03	06	15	05	00	00
				2/1 DM, 5/2 DM, 14/5 DM	CUSTOM	13	26	65	05	65	00
Netherlands	1 Hfl	2.5 Hfl	2.5 Hfl	1/1 Hfl, 3/2.5 Holland Florin ²	NETHERL	06	15	15	05	00	00
	25c	-	1 G	1/25c, 5/1 Guilder	CUSTOM	01	00	05	01	00	00
	1 G	-	1 G	1/1 Guilder ²	HOLLAND	01	00	01	01	00	00
Sweden	5 Kr	5 Kr	5 Kr	1/5 Krona ²	SWEDEN	01	01	01	01	00	00
	1 Kr	-	1 Kr	1/2x1 Krona	CUSTOM	01	04	01	02	00	01
France	1 F	5 F	10 F	1/3x1 F, 2/5 F, 5/10 Franc ^{1,2}	FRANCE	02	10	20	05	20	00
	1 F	5 F	10 F	1/2x1 F, 3/5 F, 7/10 Franc	CUSTOM	03	15	30	05	30	00
	5 F	10 F	10 F	1/5 F, 3/10 F, 7/2x10 Franc	CUSTOM	03	15	30	10	60	15
	5 F	10 F	10 F	2/5 F, 4/10 F, 9/2x10 Franc	CUSTOM	02	10	20	05	40	10
	5 F	10 F	10 F	2/5 F, 5/10 F, 11/2x10 Franc	CUSTOM	01	05	10	02	20	05
Italy	500 L	500L	500 L	1/500 Lire ²	ITALY	01	01	01	01	00	00
Spain	25 P	-	100P	1/25 P, 5/100 Peseta ²	SPAIN	05	00	20	04	00	00
	25 P	-	100P	1/25 P, 4/100 Peseta	CUSTOM	01	00	04	01	00	00
	25 P	-	100P	1/2x25 P, 2/100 Peseta	CUSTOM	01	00	04	02	00	00
	25 P	-	100P	1/2x25 P, 3/100 Peseta	CUSTOM	03	00	12	04	00	06
Japan	-	100 ¥	-	1/100 Yen ²	JAPAN	01	00	01	01	00	00
	100 ¥	-	100 ¥	2/100 ¥	CUSTOM	01	04	01	02	00	01
Antilles, Netherl.	25c	-	1 G	1/25c, 4/1 Guilder ²	ANTILLES	01	01	04	01	00	00
Chile	Token	-	Token	1/1 Token ²	CHILE	01	04	01	01	00	00
Denmark	1 Kr	5 Kr	10 Kr	1/2x1 Kr, 3/5 Kr, 7/10 Krone ²	DENMARK	03	15	30	05	30	00
Finland	1 Mka	-	5 Mka	1/2x1 Mka, 3/5 Markka ²	FINLAND	03	00	15	05	00	00
New Zealand	20c	-	20c	1/3x20c ²	N. Z.	01	00	01	03	00	01
Norway	1 Kr	-	1 Kr	1/2x1 Kr, 3/5x1 Krone ²	NORWAY	01	00	01	02	05	00
Argentina	10c	10c	10c	1/1 Token ²	ARG.	01	01	01	01	00	00
Greece	10D	20D	50D	1/2x10D, 1/20D, 3/50 Drachma ²	GREECE	03	06	15	05	00	00

Notes:

1. Factory Default. 2. Standard Setting - Change by pressing Credit button. 3. Other functions are also affected, see the explanations for Adjustment Items 53 through 58.

TEST/DIAGNOSTIC PROCEDURES

WILLIAMS ELECTRONICS GAMES also provides a series of diagnostic tests to aid the operator in determining game condition (that is, whether the game's features and highlights are operating satisfactorily). These tests activate virtually all the electronic and electromechanical devices comprising the game, so that the operator can readily locate a malfunctioning device or simply verify that all devices are working properly. In order, these tests deal with the music, the displays, the game sounds, the lamps, the solenoids, and the switches.

In addition to the diagnostic testing, a feature called the Auto Burn-in Mode is available. Activating this mode enables the operator to observe the game while all of the diagnostic tests, *except the switch tests*, occur. This can be very helpful in locating 'intermittent' problems.

Activating either the entire test series or one of the individual tests requires use of the Game Adjustment/ Diagnostic switches. Open the coin door for access to these switches. To proceed to the Diagnostic Tests, the operator must simply switch the game On, set the AUTO-UP/MANUAL-DOWN switch to MANUAL-DOWN, and press the ADVANCE button.

CAUTION

The System-11B game program greatly aids the operator and service personnel: At the beginning of the Test/Diagnostic Procedures (and also at game Turn-On), the player score displays now signal, with a message ("Press ADVANCE for Report") that the game program has detected a problem that affects game play. Messages for POLICE FORCE include "Adjust Switch ##", "Pinball Missing", "Car Up Error", "Car Down Error", "Diverter In Error", "Diverter Out Error", and Music Failure". Refer to the text on Problem Analysis Messages at the end of the Test/Diagnostic Procedures for more details concerning the messages' meaning. To proceed with the Test/Diagnostic Procedures, use AUTO-UP, and press ADVANCE.

MUSIC TEST.

1. In the Music Test, observe that the upper displays show the message, MUSIC TEST. Switching to AUTO-UP, observe that the message now reads MUSIC OFF, and that the lower display shows 00 00. Press the Credit button to select the desired music selection: 01 - 'Main Theme' through 05 - 'Hi. Score Theme' (the selections repeat). Adjust the volume control for proper sound level for the game location.
2. Use the AUTO-UP position.

DISPLAY TEST.

1. To initiate the Display Test, press ADVANCE. Observe that upper display briefly shows the message, DISPLAY TEST, and that the lower display shows 01 (the Display Test identifier).
2. Use AUTO-UP. Observe that all displays begin a display cycle of all 0s through all 9s, one digit at a time. Verify that the proper comma segments light during display of the odd-numbered digits. Next, a special "all segments" character 'walks' from left to right across each player score display.
3. To halt the display cycle, use MANUAL-DOWN. Then, press ADVANCE to step through the sequential digit display, digit by digit, and the subsequent "all segments" characters display test. Use AUTO-UP to resume cycling, and to proceed to the next test.

SOUND TEST.

1. (From Display Test) To initiate the Sound Test, press ADVANCE. Observe that the upper displays show the message, SOUND TEST, and that the lower display shows 02 (the Sound Test identifier). The lower display shows a series of test steps from 00 through 07. Verify that a different sound is heard each time the number in the display changes.
2. To repeatedly pulse a single sound, use MANUAL-DOWN. Verify that one particular sound repeats. Press ADVANCE to step to the next sound, which repeats until ADVANCE is pressed again. Use AUTO-UP to resume cycling the sounds, and to proceed to the next test.

TEST/DIAGNOSTIC PROCEDURES (Continued)

LAMP TESTS.

1. All Lamps.

(From Sound Test) To initiate the first Lamps Test, press ADVANCE. Observe that the upper displays show the message, ALL LAMPS, and that the lower display shows 03 (All Lamps Test identifier) and that all feature lamps (playfield and backbox) blink on and off. (Note, however, that the General Illumination lamps remain lighted steadily.) To locate the wiring associated with a particular feature lamp, refer to the **Lamp-Matrix Table**. CPU Board connections at jacks 1J6 (columns) and 1J7 (rows) are also listed in the table.

2. Single Lamps.

From the All Lamps test, using AUTO-UP, press ADVANCE to initiate the Single Lamps Test. The upper displays initially show the message, SINGLE LAMPS, and the lower display shows 04. Then, the lower display shows 04 01, and the upper displays change to show "HOT SCORE", the name of the lamp currently blinking. Press the Credit button to proceed through an ascending series of designator numbers (01 through 64), with the upper displays showing the individual lamp's name. (To proceed through a descending series of lamp identifiers, use MANUAL-DOWN.) Press and hold the Credit button to proceed rapidly to the desired lamp.

POLICE FORCE Lamp-Matrix Table

COLUMN ROW	1 Q65 YEL-BRN 1J7-1	2 Q64 YEL-RED 1J7-2	3 Q62 YEL-ORN 1J7-3	4 Q60 YEL-BLK 1J7-4	5 Q58 YEL-GRN 1J7-5	6 Q56 YEL-BLU 1J7-7	7 Q54 YEL-VIO 1J7-8	8 Q52 YEL-GRY 1J7-9
Q60 RED- BRN 1J6-1	Hot Sheet Hot Score 1	2X 9	P 17	10k (Mdl Ramp) 25	Shark 33	Jackpot W/L 41	Right Outlane 49	L 3-Bank Stndup Tgt (upr) 57
Q61 RED- BLK 1J6-2	Hot Sheet Extra Ball 2	3X 10	O 18	20k (Mdl Ramp) 26	Croc 34	Skill 10K (Fring Range) 42	Left Outlane 50	L 3-Bank Stndup Tgt (mdl) 58
Q62 RED- ORN 1J6-3	Hot Sheet 5 Free Games 3	4X 11	L 19	50k (Mdl Ramp) 27	Drug Rat 35	Skill 25K (Fring Range) 43	Left Return 51	L 3-Bank Stndup Tgt (lwr) 59
Q63 RED- YE 1J6-5	Hot Sheet Multi-Ball 4	5X 12	I 20	75k (Mdl Ramp) 28	Weasel 36	Skill 50K (Fring Range) 44	Right Return 52	Scope (Backglass) 60
Q64 RED- GRN 1J6-6	Hot Sheet Spot P-O-L-I-C-E 5	6X 13	C 21	100k (Mdl Ramp) 29	Shark In Jail 37	Skill 75K (Fring Range) 45	Take Highest 53	L Jackpot (Backglass) 61
Q65 RED- BLU 1J6-7	Spot Police 6	Special W/L 14	E 22	150k (Mdl Ramp) 30	Croc In Jail 38	Skill 100K (Fring Range) 46	G 54	R Jackpot (Backglass) 62
Q66 RED- VIO 1J6-8	Lock 1 7	Hot Sheet Bonus W/L 15	Top Extra Ball 23	Unlimited Million W/L 31	Drug Rat In Jail 39	Car Headlight 47	U 55	L Dome (Backglass) 63
Q67 RED- GRY 1J6-9	Lock 2 8	Adv. Handoff Bonus 16	Shoot Again 24	Top Cop Bonus 32	Weasel In Jail 40	Car Headlight 48	N 56	R Dome (Backglass) 64

TEST/DIAGNOSTIC PROCEDURES (Continued)

SOLENOID TEST.

- (From Lamp Test) Using AUTO-UP, press ADVANCE. Observe that the upper display shows the message, COIL TEST, the lower display shows 05 (Solenoid Test identifier). Next, the lower display shows a series of test steps from 01 through 22, while the upper display shows the solenoid/circuit name. During each of these steps, pulsing of the respective solenoid/circuit occurs. The test cycles repeatedly, unless halted via the MANUAL-DOWN switch. Refer to the **Solenoid Table** for solenoid numbers and wiring information. CPU Board connections at 1P11, 1P12, and 1P19 are also listed in the table.

To continuously pulse a single solenoid/circuit, use MANUAL-DOWN. Press ADVANCE to sequence through the switched, controlled, and special solenoids. Use AUTO-UP to resume test cycling, and to proceed to the next test.

POLICE FORCE Solenoid Table

Sol. No.	Function	Solenoid Type	Wire Color	Connections		Driver Trmtr	Solenoid Part Number Flashlamp Type
				CPU Bd	Playfield/ Cabinet		
01A ³	Outhole Kicker	Switched	Vio-Brn	1P11-1	5J1-9; 5J4-9 (A)	Q33	AE-23-800
01C ³	Shark Flashers	Switched	Blk-Brn	(Gry-Brn)	5J5-9 (C)	Q33	#906/#89 flashlamps 1p, 1i
02A ³	Top Left Eject	Switched	Vio-Red	1P11-3	5J1-7; 5J4-8 (A)	Q25	AE-23-800
02C ³	Croc Flashers	Switched	Blk-Red	(Gry-Red)	5J5-8 (C)	Q25	#906/#89 flashlamps 1p, 1i
03A ³	Ball Diverter	Switched	Vio-Orn	1P11-4	5J1-6; 5J4-7 (A)	Q32	AE-26-1200
03C ³	Rat Flashers	Switched	Blk-Orn	(Gry-Orn)	5J5-7 (C)	Q32	#906/#89 flashlamps 1p, 1i
04A ³	Right 3-Bank Drop Tgt Reset	Switched	Vio-Yel	1P11-5	5J1-5; 5J4-6 (A)	Q24	AE-26-1200
04C ³	Weasel Flashers	Switched	Blk-Yel	(Gry-Yel)	5J5-5 (C)	Q24	#906/#89 flashlamps 1p, 1i
05A ³	Lwr Right Eject	Switched	Vio-Grn	1P11-6	5J1-4; 5J4-5 (A)	Q31	AE-23-800
05C ³	Jackpot/Scope Flashers	Switched	Blk-Grn	(Gry-Grn)	5J5-4 (C)	Q31	#906/#89 flashlamps 1p, 2i
06A ³	Mdl 3-Bank Drop Tgt Reset	Switched	Vio-Blu	1P11-7	5J1-3; 5J4-4 (A)	Q23	AE-26-1200
06C ³	Million Flasher	Switched	Blk-Blu	(Gry-Blu)	5J5-3 (C)	Q23	#906 flashlamp 1p
07A ³	Knocker	Switched	Vio-Blk	1P11-8	5J1-2; 5J4-2 (A)	Q30	AE-23-800
07C ³	L Dome Flashers	Switched	Blk-Vio	(Gry-Vio)	5J5-2 (C)	Q30	#906 flashlamps 2d
08A ³	Top Right Eject	Switched	Vio-Gry	1P11-9	5J1-1; 5J4-1 (A)	Q22	AE-23-800
08C ³	R Dome Flashers	Switched	Blk-Gry	(Gry-Blk)	5J5-1 (C)	Q22	#906 flashlamps 2d
09	Take Highest Flashers	Controlled	Brn-Blk	1P12-1	5J2-9; 5J6-9; 2J4-3	Q17	#89 flashlamps 1p, 1i
10	Playfield Grn Illum Relay	Controlled	Brn-Red	1P12-2	5J2-8; 5J6-8; 2J4-5	Q9	5580-09555-01 4a
11	Backbox Grn Illum Relay	Controlled	Brn-Orn	1P12-4	5J2-6; 5J6-7; 2J4-6	Q16	5580-09555-01 4a
12	A/C Select Relay	Controlled	Brn-Yel	1P12-5	5J2-5	Q8	5580-09555-01 5
13	Skill Flasher	Controlled	Brn-Grn	1P12-6	5J2-4; 5J6-5	Q15	#906 flashlamp 1p
14	Top Cop Flashers	Controlled	Brn-Blu	1P12-7	5J2-4; 5J6-3	Q7	#906 flashlamps 2p
15	Car On/Off Motor	Controlled	Brn-Vio	1P12-8	5J2-2; 5J6-2	Q14	14-7953
16	Car Up/Down Relay	Controlled	Brn-Gry	1P12-9	5J2-1; 5J6-1	Q6	5580-09555-01 4a
17	Left Jet Bumper	Special #1	Blu-Brn	1P19-7	5J3-7; 5J7-7	Q75	AE-23-800
18	Left Kicker ("sling")	Special #2	Blu-Red	1P19-4	5J3-6; 5J7-6	Q71	AE-26-1500
19	Right Jet Bumper	Special #3	Blu-Orn	1P19-3	5J3-3; 5J7-3	Q73	AE-23-800
20	Right Kicker ("sling")	Special #4	Blu-Yel	1P19-6	5J3-4; 5J7-5	Q69	AE-26-1500
21	Lower Jet Bumper	Special #5	Blu-Grn	1P19-8	5J3-2; 5J7-2	Q77	AE-23-800
22	Ball Release (Shtr Lane Feeder)	Special #6	Blu-Blk	1P19-9	5J3-1; 5J7-1	Q79	AE-23-800
-	<u>Right Flipper</u>	-	Orn-Vio	1P19-1	2J5-5; 2J10-7	-	FL11630/50VDC
-	Lower Right Flipper	-	[Blu-Vio] ²		[2J10-1; 2J8-15]		
-	<u>Left Flipper</u>	-	Orn-Gry	1P19-2	2J5-4; 2J10-8	-	FL11630/50VDC
-	Lower Left Flipper	-	[Blu-Gry] ²		[2J10-2; 2J8-4]		

Notes 1. Wire colors, except flipper Orn-Vio and Orn-Gry, are ground connections (to coil terminal with unbanded end of diode). Flipper Orn-Vio and Orn-Gry wires connect from CPU Board to flipper switch. 2. Flipper connections shown in braces are from flipper switch to flipper coil. 3. "A" circuits are pulsed, when Sol. 12 is de-energized; "C" circuits are pulsed, with Sol. 12 energized. Wire colors in brackets are those from respective A and C terminals corresponding to the J1-terminal connection listed for the Aux Power Driver Bd, which controls the device pulsing by Sol. 12. 4. Relay is mounted on Relay Bd, (4a) p/n C-11998-1; (4b) C-11902-1. 5. Relay is mounted on Aux Power Driver Bd, D-12247 in the backbox.

TEST/DIAGNOSTIC PROCEDURES (Continued)

"On" State Logic - Special Solenoid

"On" State Logic - Controlled Solenoid

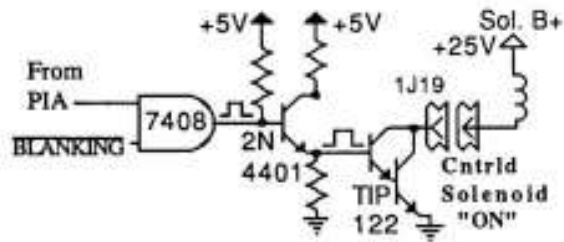
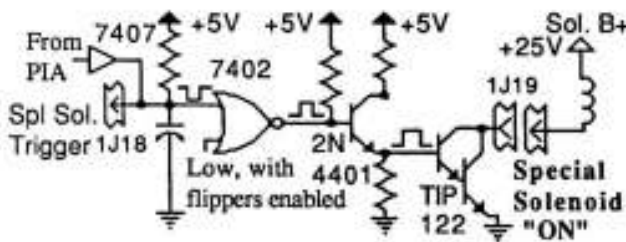

"Off" State - Special Solenoid:

The Special Switch Trigger Input goes low. Meanwhile, the PIA line remains high. The remaining signals reverse their states.

"Off" State - Controlled Solenoid:

The Enable Input (from the PIA) goes low. Meanwhile, the BLANKING signal remains high. The rest of the signals reverse their states.

NOTE

As directed by the game program, the Solenoid A/C Select Relay (solenoid 12) switches the solenoid B+ power between two power busses to permit actuating two groups of solenoids at the proper times. In its de-energized state, the Relay connects the 'circuit A power' to 16 "controlled" and "switched" solenoids (identified in the table with no suffix letter or the letter A, after the solenoid number). Individual solenoid operation then depends on the game program enabling the ground path for solenoid actuation via the driver transistor associated with each solenoid circuit. For example, the game program can actuate the Outhole Kicker solenoid (sol. 01A), via the driver transistor Q33.

When the game program determines that the Solenoid A/C Select Relay (sol. 12) must be energized, the relay connects 'circuit C power' to eight group C solenoids (01C through 08C). Now, driver transistor Q33 can actuate the Shark Flashers circuit (sol. 01C), which has two lamp circuits; one to the Insert Board and one to the playfield. Using this "multiplexing" technique, the same driver transistor can control actuation of two separate (A side and C side) solenoid circuits.

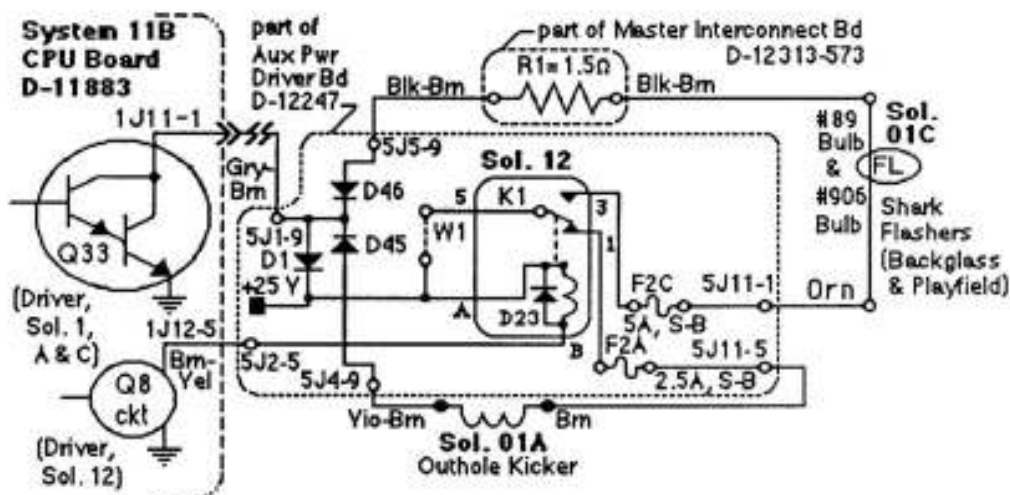

Figure 4. Typical Solenoid A/C Select Relay Circuit, showing the function of Solenoid 12, the Solenoid A/C Select Relay.

TEST/DIAGNOSTIC PROCEDURES (Continued)

SWITCH TESTS.

1. Switch Levels.

(From Solenoid Test) To initiate the Switch Levels Test, press ADVANCE. Observe that the upper display shows the message, SWITCH LEVELS, and the lower display shows 06 (Switch Levels Test identifier). Normally, the right portion of the lower display remains blank, indicating that no switch is actuated.

If, however, a switch *is* actuated (possibly stuck closed), the lower display shows that switch's number, while the upper displays indicate the switch's name. A sound also accompanies the displays. (This is another facet of the POLICE FORCE System-11B's switch testing capability.) If more than one switch is closed, a series of displays show each actuated switch's name and number.

(In addition, either of these problems could result in the reporting of a switch problem (or problems) at game Turn-On or at the beginning of Diagnostic Tests.)

As soon as the operator opens a closed switch, its name and number are eliminated from the Switch Levels display series. For POLICE FORCE, switch numbers can range from 01 through 64. Refer to the **Switch-Matrix Table** for switch numbers and wiring information. CPU Board connections at jacks 1J8 (columns) and 1J10 (rows) are also listed in the table.

POLICE FORCE Switch-Matrix Table

COLUMN \ ROW	1 Q45 GRN-BRN 1J8-1	2 Q49 GRN-RED 1J8-2	3 Q44 GRN-ORN 1J8-3	4 Q48 GRN-YEL 1J8-4	5 Q43 GRN-BLK 1J8-5	6 Q47 GRN-BLU 1J8-7	7 Q42 GRN-VIO 1J8-8	8 Q46 GRN-GRY 1J8-9
1	WHT-BRN 1J10-9 Plumb Bob Tilt 1	Playfield Tilt 9	L 3-Bank Stndup Tgt (upr) 17	Mid 3-Bank Dr Target (upr) 25	33	SkillSwitch (Spinner) 41	Right Outlane 49	Flipper Right 57
2	WHT-RED 1J10-8 C Side Power A/C Relay 2	Outhole 10	L 3-Bank Stndup Tgt (mid) 18	Mid 3-Bank Dr Target (mid) 26	Enter Right Ramp 34	42	Left Outlane 50	Flipper Left 58
3	WHT-ORN 1J10-7 Credit Button 3	Ball Trough #1 (R) 11	L 3-Bank Stndup Tgt (lwr) 19	Mid 3-Bank Dr Target (lwr) 27	Top Left Tgt (Top Cop) 35	43	Left Return Lane 51	59
4	WHT-YEL 1J10-6 Right Coin Chute 4	Ball Trough #2 (L) 12	R 3-Bank Dr Target (upr) 20	28	Diverter In 36	44	Right Return Lane 52	Left Jet Bumper 60
5	WHT-GRN 1J10-5 Center Coin Chute 5	13	R 3-Bank Dr Target (mid) 21	29	R Ramp to Car 37	Enter Mdl Ramp 45	53	Right Jet Bumper 61
6	WHT-BLU 1J10-3 Left Coin Chute 6	Ball Shooter 14	R 3-Bank Dr Target (lwr) 22	30	R Ramp to Wire 38	Mdl Ramp Score 46	G 54	Lwr Jet Bumper 62
7	WHT-VIO 1J10-2 Slam Tilt 7	Top Right Eject 15	BR Eject 23	Car Up 31	39	47	U 55	BL Kicker ("sling") 63
8	WHT-GRY 1J10-1 High Score Reset 8	16	Top Left Eject 24	Car Down 32	40	48	N 56	BR Kicker ("sling") 64

BL - Bottom Left BR - Bottom Right

Row Problems. If a display of two (or more) switch numbers of a row occurs, although only one switch is closed, check for a short circuit between the column wires.

Multiple Switch Number Indications. Check the associated column wire for a short circuit to ground.

Column Problems. If display of two (or more) switch numbers in a column occurs (while only one switch is actuated), check for a short circuit between the row wires.

Use AUTO-UP to proceed to the next test.

TEST/DIAGNOSTIC PROCEDURES (Continued)

SWITCH TESTS (Continued).

2. Switch Edges.

From the Switch Levels Test, press ADVANCE. Observe that the upper display shows the message, SWITCH EDGES; the lower display shows 07 (Switch Edges Test identifier). The right portion of the lower display is blank, indicating that no switch is actuated.

This test permits the operator to test whether actuating a switch provides the proper signal to the System-11B switch testing program. When actuating a switch, the operator should see the switch's name and number in the displays. If no indication appears at the time the switch is actuated, the operator then knows that there is a malfunction associated with that switch.

Using this technique, the operator can test each switch appearing in the **POLICE FORCE** switch problem reporting displays (either at game Turn-On or at the beginning of the Diagnostic Tests) to determine whether the switch can be actuated. If the switch's name and number are displayed while the operator checks its operation, the operator then knows that the reported problem with that switch is **NOT** currently caused by a switch malfunction. The operator can then seek other causes for the reported problem, being almost certain now that the switch did not fail. *This test is also useful when the operator is adjusting the sensitivity of a particular switch's actuation mechanism.*

Among the possibilities is the fact that the players have not actuated that switch because of some other problem; the operator should try to analyze what could cause the switch to be missed during game play, and remedy that problem cause. With these new tests, switch problems are, therefore, more easily isolated.

3. *Playfield or CPU Board?* To determine whether a switch problem is in the playfield or the CPU Board, remove connectors 1P8 and 1P10 from the CPU Board. Begin the Switch Test. Use a jumper wire to simulate switch actuation. For example, placing a jumper between 1J10-9 and 1J8-2 should (based on the **Switch-Matrix Table**) should produce an indication of switch 09 being actuated.

C-SIDE TEST

From the Switch Test, press ADVANCE. Observe that the upper display shows a message, C-SIDE TEST, and that the lower display shows 08 (C-Side Test identifier). This test confirms that Solenoid A/C Select Relay (Sol. 12) does alternate between the "A" and "C" sides of the circuitry.

The upper display then changes to show the 'side' of the circuit being tested, alternating the relay between "SELECTED A-SIDE" and "SELECTED C-SIDE", while the lower display shows the state of the C-Side Switch. While the "SELECTED C-SIDE" test is occurring, when the C-Side Switch closes, the lower display shows "C-SIDE". When the "SELECTED A-SIDE" message appears, the word "Err" appears in the lower display to indicate that there is no electrical connection from the C-side to the A-side. The message "Err" also appears whenever the C-Side Switch is not operating properly. Causes of improper operation can be blown fuses (F8 or F2C) or a faulty relay on the Aux Power Driver Board; failure of the 12 or 24 volt power circuits; a switch matrix failure; or faulty connections between the circuit boards in the game's backbox (CPU Board, Aux Power Driver Board, Backbox Interconnect Board). To halt the A/C Relay's operation, press MANUAL-DOWN and press ADVANCE to activate the A/C Relay manually.

CAR TEST

From the Switch Test, in AUTO-UP, press ADVANCE. Observe that the upper display shows the message, CAR TEST, and that the lower display shows 09 (Car Test identifier). This test confirms that the Police Car's lamps operate and that the program has proper control of the car's operation.

TEST/DIAGNOSTIC PROCEDURES (Continued)

CAR TEST (Continued)

Initially, the car lamps light to indicate that the Car Test is operating. If a lamp problem is evident (lamp(s) off, or any blinking during operation of the test), examine the lamp cable for problems (faulty lamps, broken wires, etc.), and repair.

In AUTO-UP, the entire Car Up-Down Test automatically repeats. In MANUAL-DOWN, press ADVANCE to operate the car. A lower display showing "U" indicates that the 'Car Up' switch (#31) is actuated; a "D" display appears, upon actuation of the 'Car Down' switch (#32). A lower display of "Err" occurs when the car does NOT reach its destination on its *FIRST* try. When the car NEVER reaches its destination, the message "CAR ? PRESS START" appears to notify the operator that the Game Start button must be pressed to continue the Car Test.

ENDING THE DIAGNOSTIC TESTS.

To end the Diagnostic Tests, reach the Car Test (09 in the Player 3 display), use AUTO-UP and press ADVANCE. The backbox displays should show the **POLICE FORCE** game's Identification Information (the Id 00 screen). Use MANUAL-DOWN, and press ADVANCE to reach Adjustment Item 70 (INSTALL FACTORY). Use AUTO-UP, and press ADVANCE to go to the Attract Mode.

AUTO BURN-IN MODE.

The Auto Burn-in Mode permits the operator to check intermittent (or nonrecurring) problems associated with most portions of the game's circuitry. Repeatedly cycling through a group of tests can sometimes bring a problem, which occurs only randomly or occasionally, to exhibit itself more frequently, thereby aiding in the isolation of the problem. To activate the Auto Burn-in Mode:

1. While in the Game Adjustments, reach Ad 67 and change the Factory Setting of NO to YES, via the Credit button. Set the AUTO-UP/MANUAL-DOWN switch to AUTO-UP.
2. Press ADVANCE to start the Auto Burn-in Mode. This mode repeatedly sequences through the Music Test, the Display Test, the Sound Test, the All Lamps portion of the Lamp Test, and the Solenoid Test.
3. To halt the Auto Burn-in Mode, switch the game Off and then On. **POLICE FORCE** now starts in the Attract Mode. (If a switch problem is now reported by the displays, perform the Switch Tests again to determine the nature of the problem; then, perform necessary repairs.)

SYSTEM-11B MEMORY CHIP TEST.

A new feature is now included in the Memory Chip Test for System 11B. During power-up, the CPU performs a self-testing routine. When all tests are satisfactory, the game proceeds to the Attract Mode, allowing players to use the game. Whenever a portion of the testing does not produce satisfactory results, the game displays a message, before proceeding to the next portion of the testing. ONLY after all tests are satisfactory does the game allow play to begin.

In addition to the displayed message, when any part of the self-test routine fails, LED2 ('DIAGNOSTIC'), mounted on the CPU Board, can be observed to determine the probable cause of the problem. This LED blinks, or flashes, a certain number of times to identify the probable cause, as described in the **CPU LED Indicator Codes Table**. The operator can also start the self-test routine by pressing the CPU Diagnostic Switch (SW 2) on the edge of the CPU Board.

CPU LED Indicator Codes Table

Diagnostic LED		
Blinks/ Flashes	Display Message	Explanation
1	U25 RAM FAILURE	U25 RAM could not be used properly (NO other tests are performed; the game is locked here, until the game is turned off).
2	MEM. PROT. FAILURE	This message means that (A) the Coin Door may be shut; (B) the Memory Protect Switch may be stuck in the ON position; (C) the memory protect logic is protecting the memory; or (D) a U25 RAM failure is occurring. (See Note 1)
3	U51 PIA FAILURE	U51 has a malfunction. (See Note 2)
4	U38 PIA FAILURE	U38 has a malfunction. (See Note 2)
5	U41 PIA FAILURE	U41 has a malfunction. (See Note 2)
6	U42 PIA FAILURE	U42 has a malfunction. (See Note 2)
7	U54 PIA FAILURE	U54 has a malfunction. (See Note 2)
8	U10 PIA FAILURE	U10 has a malfunction. (See Note 2)
9	IRQ FAILURE	IRQ has a malfunction. It may be missing or too fast or too slow.
10	U27 ROM FAILURE	U27's internal checksums do not match. It may be a ROM failure, or its associated connections and connecting devices are causing it to appear to have a problem. (The following U26 test is skipped.)
11	U26 ROM FAILURE	U26's internal checksums do not match.
<p>Notes: 1. This test assumes that the Coin Door is OPEN; it is initiated ONLY by pressing the CPU Diagnostic Switch (SW2).</p> <p>2. Alternatively, its associated connections or connecting devices are causing the IC to appear to have problems.</p>		

SYSTEM-11B SOUND CIRCUITRY TESTS.

Tests of the System-11B Sound circuitry, including the Audio Board, are possible only after successful completion of the System-11B Memory Chip Test.

- 1. Audio Board Test.** A brief check of the Audio Board (D-11581) circuitry occurs at game Turn-on; the game reports the test results by brief sounds, as follows: No sound = Audio Board is not operating, or a failure is affecting the sound circuitry (broken cable; dead amplifier; etc.); 1 sound = system OK; 2 sounds = RAM problem; 3 sounds = U4 problem; 4 sounds = U19 problem.
- 2. General System-11B Sound Test.** Press the Sound Diagnostic Switch (SW 1) on left edge of the CPU Board. Listen for the two test sounds, showing that both the CVSD (Continuously Variable Slope Delta) Modulator, which provides the voices for **POLICE FORCE**, and the DAC (Digital-to-Analog Converter) sound circuits are functioning properly.

If no sound is heard, refer to the text entitled "**NO SOUND ...**". If one "ring" is heard, this indicates a malfunction of the U23 RAM Chip. If either two or four "rings" is heard, this indicates a problem associated with the U21 ROM Chip. If either three or five "rings" is heard, this indicates a problem with the U22 ROM Chip.

NO SOUND DURING THIS TEST (but sound can be heard during the Diagnostic Tests).

Check the sound-select inputs (pins 2 through 9 of U9) to see if they pulse during Sound Test 01. Also, check the -12 V supply voltage on the CPU Board. If this voltage is low (or AC ripple seems too high), perform the following checks:

1. The gray and gray-green transformer secondary wires for 19.4 VAC.
2. The CPU Board filter capacitor C26 for -12 VDC.
3. The filter capacitor C26 for excessive AC ripple (over 0.75VAC).

TEST/DIAGNOSTIC PROCEDURES (Continued)

SYSTEM-11B SOUND CIRCUITRY TESTS (Continued)

If the previous checks did not isolate the problem, turn the Volume Control for maximum output. Momentarily touch a powered-up AC soldering pencil on the center tap of the Volume Control.

CAUTION

DO NOT use a soldering iron over 40 watts. Note also that cordless soldering irons will NOT work for this test.

Hearing a low hum or a 'click' indicates that the power amplifier (U1, TDA2002), the Volume Control, and the speaker are operating satisfactorily, as is the sound circuit cabling. Not hearing a sound requires repeating the test with the Volume Control turned part way down, to determine whether the Volume Control is faulty. Also, check the cable connectors for proper mating, and that no broken wires affect this circuit.

PROBLEM ANALYSIS MESSAGES.

The SYSTEM 11B game program has a great capability to aid the operator and service personnel: At Game Turn-on (and also at the beginning of the ITest/Diagnostic Procedures) after the game has been operating for an extended period, the player score displays now *may* signal with a message. "Press ADVANCE for Report", that the game program has detected a possible problem with the game.

To obtain details of the problem, open the coin door and press the AUTO-UP/MANUAL-DOWN switch to MANUAL-DOWN. Press the ADVANCE button to begin displaying the message(s). The following messages apply to your **POLICE FORCE** game.

Adjust Switch ##. This message indicates that at least one switch was stuck 'On' at game turn-on or has NOT been actuated during ball play (for 90 balls or ~30 games) by displaying the message "Adjust Switch ##", listing each problem switch by number. (The game program compensates the game play requirements affected by each disabled switch to allow 'nearly normal' play. This helps keep **POLICE FORCE** earning good profits!)

To verify the problem, refer to the Test/ Diagnostic Procedures text describing Switch Testing, and check each reported switch using applicable Switch Levels and Switch Edges tests. Always check switch operation using a ball to simulate game conditions. (Switch problems may often be resolved by adjusting the wire switch actuators, fixing electric switch problems, securing loose connectors, etc. Mechanisms using 'opto switches' (drop targets, etc.) need to be checked for proper power connections (12V dc and ground).

Pinball Missing. **POLICE FORCE** normally uses two balls; however, it will operate with only one ball. This message announces that one is missing or stuck somewhere. When the ball is located, return it to the game via the Outhole. Other possibilities for this problem could be malfunctions of the Ball Trough switches (#11 and 12), the Ball Shooter switch (#14), or the 'Ramp to Wire' lock switch (#38).

Car Up Error / Car Down Error. This message indicates that the car position is improper. Perform the Car Test portion of the Test/Diagnostic Procedures to check several cycles of operation, which should be error-free. Problem causes can include switch operation ("Car Up", #31; or "Car Down", #32); slipping car belt, which requires cleaning or adjustment; intermittent or inconsistent "Car Up/Down" relay (Solenoid 16), etc.

Diverter In Err. / Diverter Out Err. This message means that the diverter is not positioning itself properly. Perform the Coil Test to verify that the diverter is functional; repair, if necessary. If the diverter is functional, go to the Switch Edges Test to check the 'Diverter In' switch (#36). An improperly attached spring can also result in a diverter error message, as can

TEST/DIAGNOSTIC PROCEDURES (Continued)

PROBLEM ANALYSIS MESSAGES (Continued)

interference by wires in the mechanism. Check complete diverter operation: (1) At game turn-on, the diverter operates to the "In" position. (2) Start a game, and slowly operate the Right Ramp's 'Ramp to Car' switch (#37) twice (simulating Multi-Ball™ Start) to operate the diverter to its "Out" position.

Music Error. This message means that no signals are coming from the Audio Board. Check Audio Board for presence of **POLICE FORCE** ROMs. Also, Check that the cable connecting the Audio and CPU Boards is firmly seated. Turn game Off, then On, to be sure only 1 'Bing' sounds. More than one 'Bing' or no 'Bing' indicates an Audio Board problem. Refer to the text about the System-11B Sound Circuitry tests for more information.

MAINTENANCE INFORMATION

Figure 5 shows the two main lubrication points of the Shooter Lane Feeder. The shaded arrows show the directions in which the Shooter Lane Feeder and other parts of its related assemblies can be adjusted for proper operation. Note that the mechanisms of the Top Left, Top Right, and Bottom Right Eject Hole Arm Assemblies are quite similar to the Shooter Lane Feeder; they have the same lubrication requirements and adjustment capabilities as the Shooter Lane Feeder.

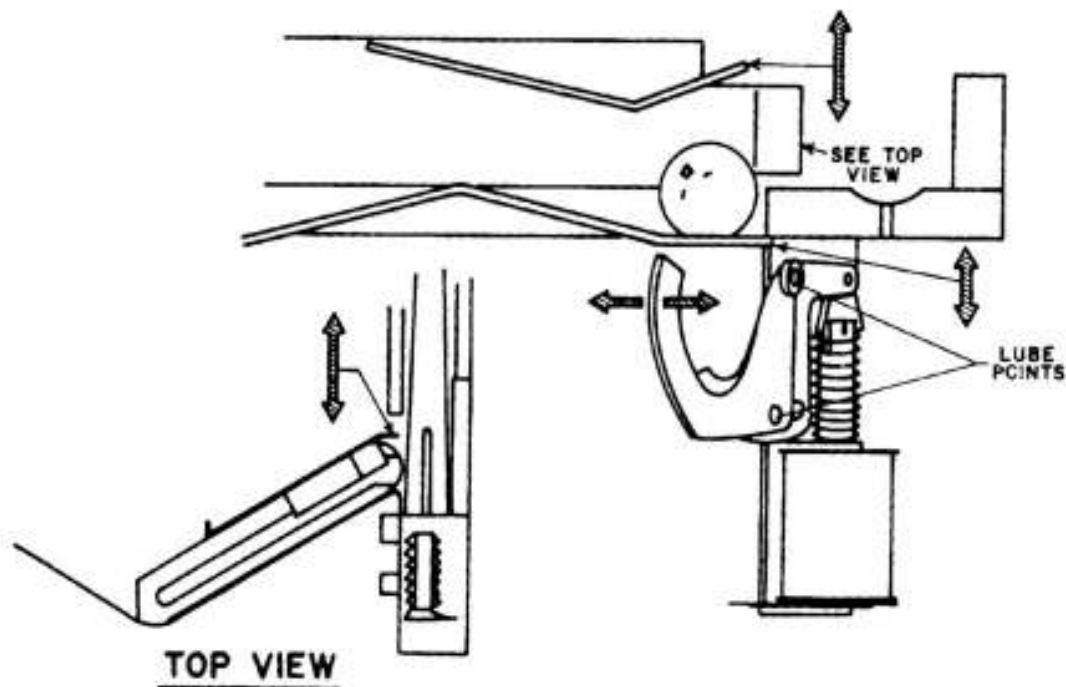
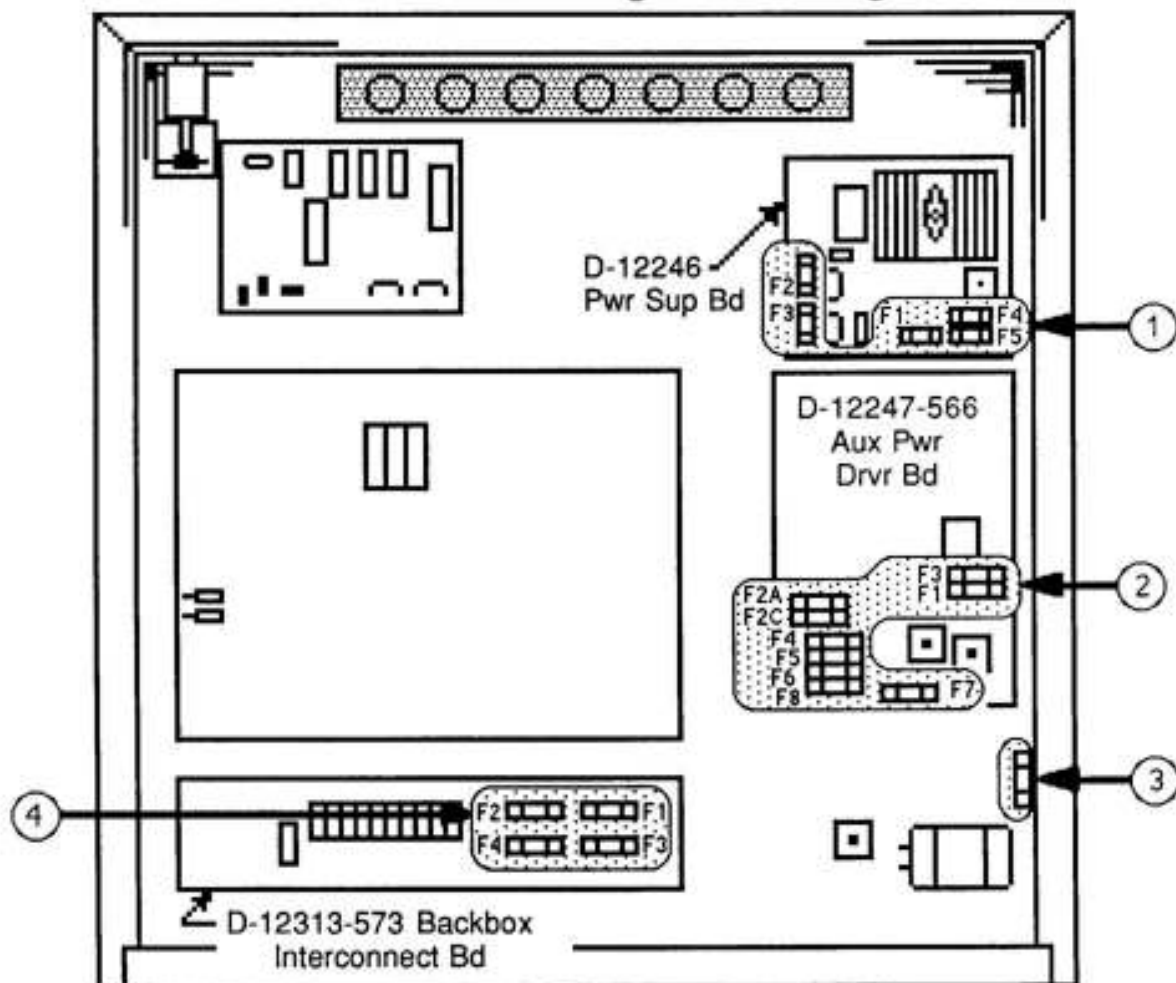

Figure 5. Adjustments and Lubrication Points, Shooter Lane Feeder.

Because of the functional design (arm-actuated via solenoid plunger operation), the pivot points of the Left and Right Kickers ("Slingshots") all require lubrication as a regular servicing procedure. Mechanical adjustments are simple and somewhat similar to the Shooter Lane Feeder. These mechanisms should also be checked for proper fit (snugly tight) where they attach to the playfield. Lubrication to ensure proper operation also applies to the target blades of the two 3-Bank Drop Targets. Regular maintenance is essential to a game's continuing contribution to the operator's earnings.

Fuse Locations Diagram & Listing



Fuse Listing

Item	Part Number	Description	Circuit/Location
1	5731-12328-00	Fuse, 3/8A., S-B, 250V	F1; D-12246 Power Supply Board
1	5731-12327-00	Fuse, 1/8A., S-B, 250V	F2, F3; D-12246 Power Supply Board
1	5731-09432-00	Fuse, 7A S-B, 250v	F4, F5; D-12246 Power Supply Board
2	5731-09128-00	Fuse, 2-1/2A., S-B, 250v	F1, F2A, F3, F4; D-12247 Aux Pwr Driver Board
2	5731-09651-00	Fuse, 5A., S-B, 250v	F2C; D-12247 Aux Pwr Driver Board
2	5731-08665-00	Fuse, 2A., S-B, 250v	F5, F6; D-12247 Aux Pwr Driver Board
2	5731-06314-00	Fuse, 4A., S-B, 250v	F7; D-12247 Aux Pwr Driver Board
2	5731-09432-00	Fuse, 7A., S-B, 250v	F8; D-12247 Aux Pwr Driver Board
3	5730-09071-00	Fuse, 8A., S-B, 32v	+18 Vdc Lamp Ckt/ Lwr Rt Backbox fuseholder (1)
4	5731-09651-00	Fuse, 5A., S-B, 250v	F1 - F4; Gen. Illumination/B'box Interconnect Board
-	5730-09252-00	Fuse, 8A., Slow-Blow (S-B), 125v	Input ("high voltage") Power Line/Cabinet Box*

* One 4A., S-B, 250v fuse (5731-06314-00) is provided for an overseas (220v) game installation.

Section 2
Game
Parts
Information

• ***Parts Lists & Diagrams***

Locations:

Game Circuit Boards and Major Mechanisms

Power Supply Board (D-12246)

Aux Power Driver Board (D-12247-566)

Backbox Interconnect Board (D-12313-573)

Audio Board (D-111581-573)

System 11-B CPU Board (D-11883-573)

Master Display Board (D-12232-2)

7-Segment Display & Lamp Boards

All Major Mechanism Assemblies of POLICE FORCE

Solenoids/Flashers & Rubber Parts

Switches

Lamps

Playfield Parts

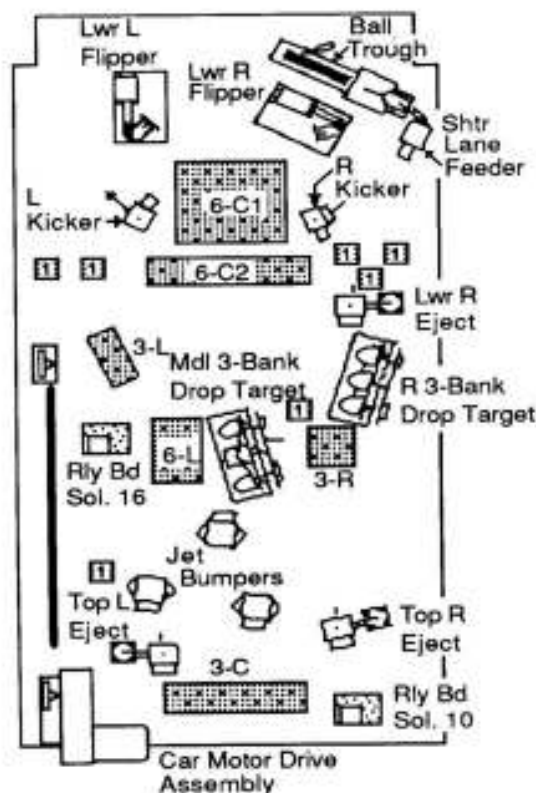

*Under side of Playfield,
Viewed in Raised Position*

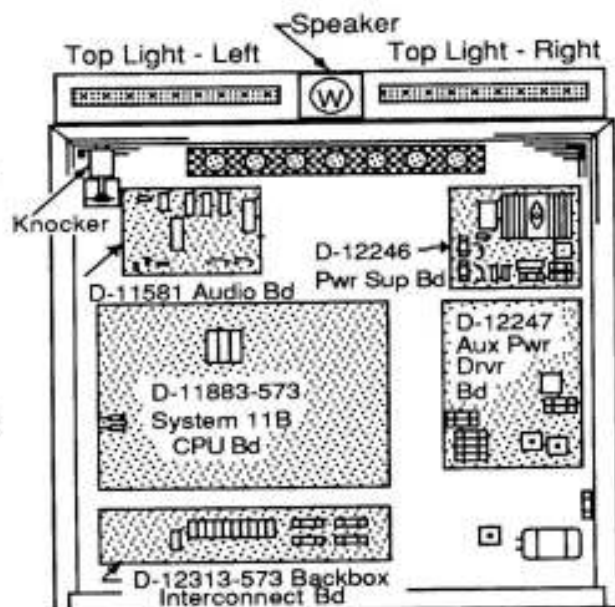
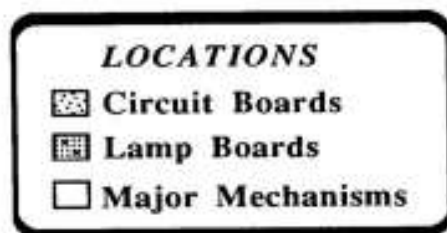

Backbox

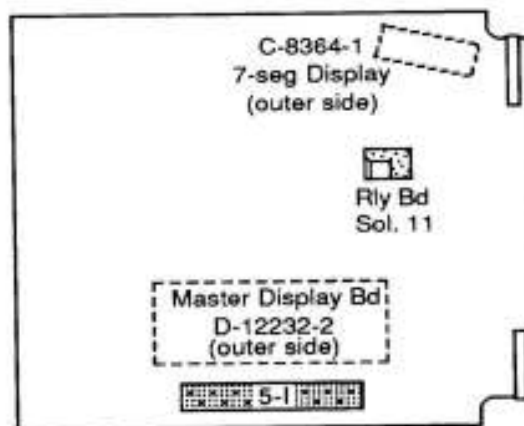

Insert Board, Inner Side View

Locations Diagram - Game Circuit Boards and Major Mechanisms

C-11626-L-1	Lower Left Flipper	B-9361-R-1	Top Right Eject Hole Arm Assy
C-11626-R-1	Lower Right Flipper	B-9362-R-1	Coil & Bracket Assembly
C-9638	Ball Shooter Lane Feeder	B-9361-R-6	TL Eject Hole Arm Assembly
B-9362-R-1	Coil & Bracket Assembly	B-9362-R-1	Coil & Bracket Assembly
C-12712	Lamp Board ("6-C1")	B-12806	Car Motor Assembly
B-12665	Left & Right Kicker Arm Assembly	C-12000	Lamp Board ("3-C")
B-11203-R-1	Coil & Bracket Assembly	C-11998-1	Relay Board (Sol. 10 Gen. Illum)
C-12713	Lamp Board ("6-C2")	C-12717	Top Light Lamp Board (Left & Right)
B-9361-R-8	Lwr Right Eject Hole Arm Assy	B-10686-1	Knocker Assembly
B-9362-R-1	Coil & Bracket Assembly	D-11581-573	Audio Board
B-12224	Lamp Board ("1")	D-12246	Power Supply Board
C-12709	Lamp Board ("3-L")	D-11883-573	System 11B CPU Board
C-11223-1	Middle & Right 3-Bank Drop Targets	D-12247-566	Aux Power Driver Board
C-12559	3-Bank Opto Board	D-12313-573	Backbox Interconnect Board
C-11998-1	Relay Board (Car Motor)	C-8364-1	7-Segment Display Board
C-12711	Lamp Board ("6-L")	C-11998-1	Relay Board (Sol. 11 Gen. Illum)
C-12710	Lamp Board ("3-R")	D-12232-2	Master Display Board
B-9414-1	Jet Bumper (Lwr, R, L)		
B-9415-1	Bumper Coil & Bracket Assy		

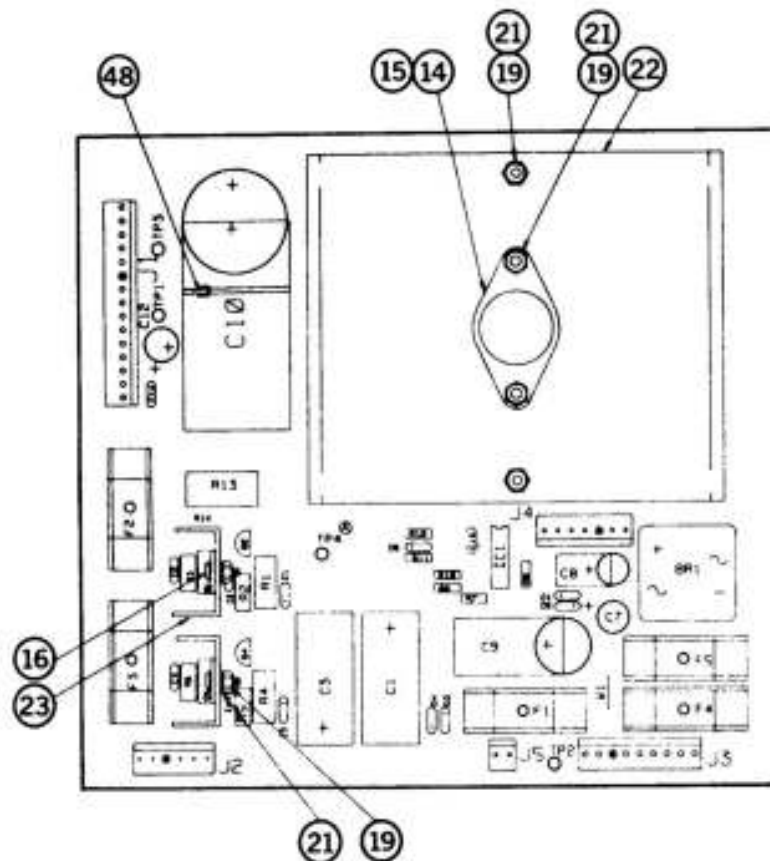

POWER SUPPLY D-12246

Item	Part Number	Ckt Designator	Description	Item	Part Number	Ckt Designator	Description
1	5765-12317-00		Power Supply PCB	27	5460-09424-00	IC1	IC, Volt. Reg., MC1723C5
2	5733-12060-01	F1-F5	Fuse Holder	28	5010-09059-00	R3, R6	Resistor, 330K, 5%, 1/2w, C.F.
3	5731-09432-00	F4, F5	Fuse, 7A., S-B, 250v	29	5010-10631-00	R2, R5	Resistor, 1.2K, 5%, 1/2w
4	5731-12328-00	F1	Fuse, 3/8A., S-B, 250v	30	5010-09536-00	R1, R4	Resistor, 39K, 5%, 1w
5	5730-12327-00	F2, F3	Fuse 1/8 A., 250v	31	5013-09426-00	R7	Resistor, 2.15K, 1%, 1/4w, C. F.
6	5791-10862-15	J1	Connector, 15-pin Hdr, Sq Pin .156	32	5013-09427-00	R8	Resistor, 4.99K, 1%, 1/4w, C. F.
7	5791-10862-06	J2	Connector, 6-pin Hdr, Sq Pin .156	33	5010-09541-00	R9	Resistor, 2.7K, 2%, 1/4w, C. F.
8	5791-10862-09	J3	Connector, 9-pin Hdr, Sq Pin .156	34	5010-09085-00	R10	Resistor, 1.5K, 5%, 1/4w, C. F.
9	5100-09690-00	BR1	Bridge Rectifier, 35A., 200V	35	5010-09428-00	R11	Resistor, 1.5K, 2%, 1/4w, C. F.
10	5164-12154-00	Q1	Transistor, MJE15030, NPN	36	5010-09508-00	R12	Resistor, 270Ω, 2%, 1/4w, C. F.
11	5194-12155-00	Q3	Transistor, MJE15031, PNP	37	5012-09429-00	R13	Resistor, 0.12Ω, 5%, 5w
12	5194-09055-00	Q2	Transistor, MPSD52, PNP	38	5040-12324-00	C1, C3	Capacitor, 150 mfd, 160v, radial
13	5164-09056-00	Q4	Transistor, MPSD02, NPN	39	5043-09072-00	C2, C4	Capacitor, 0.1 mfd, 500v, disc
14	5162-09425-00	Q5	Transistor, 2N6057, NPN	40	5040-09421-00	C7	Capacitor, 100 mfd, 25v, radial
15	5701-09652-00		Thermal Pad TD-3	41	5040-09422-00	C8	Capacitor, 47 mfd, 50v, radial
16	4006-01003-06		Mach. Screw, 6-32 x 3/8	42	5040-09420-00	C9	Capacitor, 1000 mfd, electr, 25v, axial or radial
17	4006-01003-08		Mach. Screw, 6-32 x 1/2		5040-08893-00		Capacitor, 18,000 mfd, electr, 20v, axial
18	20-9229		Thermal Compound	43	5040-09419-00	C10	Capacitor, 330 mfd, electr, 10v, radial
19	4406-01117-00		Nut, 6-32 Hex.	44	5040-09423-00	C12	Capacitor, 0.1 mfd, 50v, disc
20	5010-09534-00	W1	Resistor, 0Ω	45	5043-09446-00	C14	Capacitor, 470 pfd
21	4703-00007-00		Lockwasher, #6 Ext.	46	5043-09055-00	C15	Terminal, #1502-1 (Test Post)
22	5705-12330-00		Heatsink 4"	47	5624-09248-00	TP1-TP4	Tie Wrap, 8" Long
23	5705-09199-00		Heatsink 6030B	48	03-7947		
24	5070-09054-00	D1, D3 - D6	Diode, 1N4004				
25	5075-09059-00	ZR1, ZR3	Zener, 1N5990, 3.9v, 1/2w				
26	5075-09060-00	ZR2, ZR4	Zener, 1N4764, 100v, 1w				

NOTES:

- Heat sink compound must be applied between transistor and heat sink.
- Observe index mark on integrated circuit, polarity of capacitors and diodes, and position of transistors.
- The view of Q5 and its related heat sink and hardware is from the bottom of the heatsink, to clarify installation.

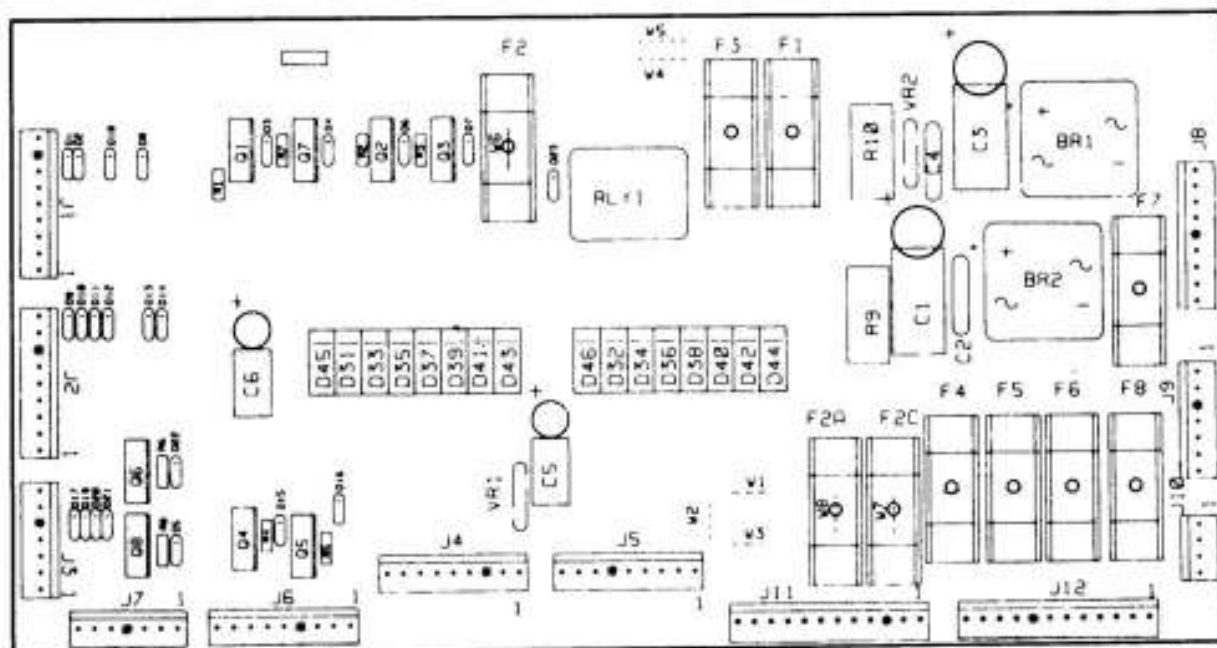

AUX POWER DRIVER UNIT BOARD D-12247-566

Part Number	Ckt Designator	Description
5763-12184-00		Bare P.C. Board
5040-09537-00	C1, C3	Capacitor, 100 μ fd., 100v, Radial
5040-12181-00	C5, C6	Capacitor, 10 μ fd., 100v, Radial
5043-09072-00	C2, C4	Capacitor, 0.1 μ fd., 500v
5010-09160-00	R1 - R8	Resistor, 220 Ω , 1/4w C.F., 5%
5012-12238-00	R9	Resistor, 3.3K Ω , 5w, 10%
5010-09534-00	W1, W3, W4, W6	Resistor, 0 Ω , 1/4w
5017-12180-00	VR1, VR2	Varistor, 100v
5100-09690-00	BR1, BR2	Bridge Rectifier, 35A, 200v
5070-08785-00	D1 - D23	Diode, 1N4003
5070-09045-00	D31 - D46	Diode, MR501
5191-12179-00	Q1 - Q8	Transistor, TIP36C
5580-09555-01	K1	Relay, DPDT, 13A
5733-12060-01		Fuse Holder
5731-08665-00	F5, F6	Fuse, 2A, S-B, 250v
5731-09128-00	F1, F2A, F3, F4	Fuse, 2-1/2A, S-B, 250v
5731-09651-00	F2C	Fuse, 5A, S-B, 250v
5731-06314-00	F7	Fuse, 4A, S-B, 250v
5731-09432-00	F8	Fuse, 7A, S-B, 250v
5791-10862-09	J1, J2, J4 - J6, J8	Connector, 9-pin Hdr, Sq Pin
5791-10862-07	J3, J7, J9	Connector, 7-pin Hdr, Sq Pin
5791-10862-12	J11, J12	Connector, 12-pin Hdr, Sq Pin
5791-10862-04	J10	Connector, 4-pin Hdr, Sq Pin
16-8850-215		PCB Label

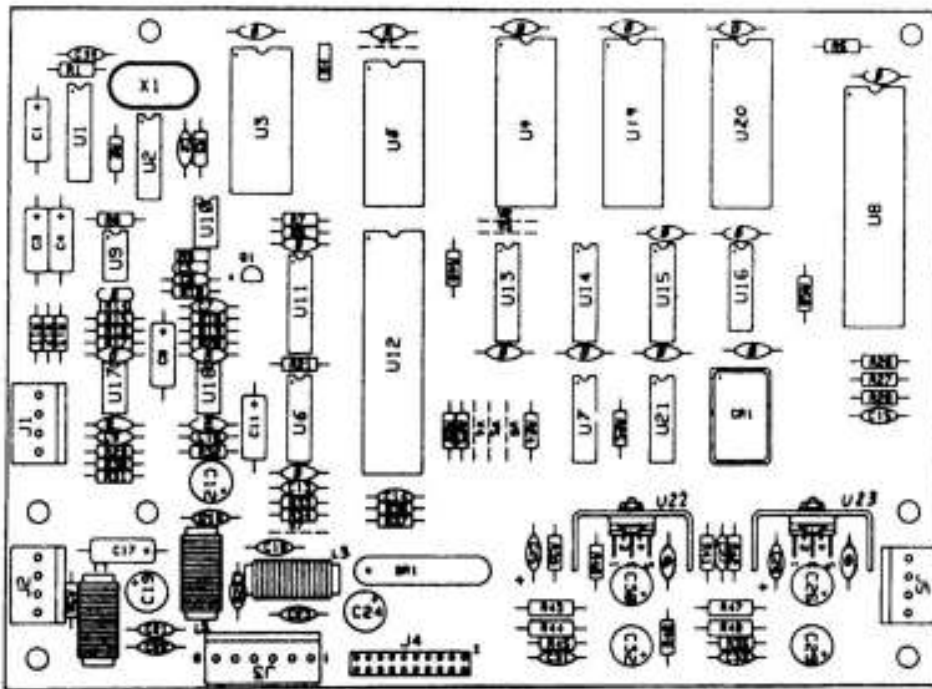

AUDIO BOARD ASSEMBLY D-11581-573

Part Number	Ckt Designator	Description	Part Number	Ckt Designator	Description
5766-12130-00		Bare P. C. Board	5010-08998-00	R2, R3, R12	Resistor, 2.2K, 1/4w, 5%
5371-11087-00	U1	IC, D/A Conv, YM3012	5010-08983-00	R7-R9	Resistor, 3.3K, 1/4w, 5%
a) 5700-09006-00		Socket, IC, 16-pin (U1)	5010-08991-00	R1, R4, R5, R11, R26 - R28, R33, R36, R37, R49, R50	Resistor, 4.7K, 1/4w, 5%
5370-11086-00	U3	IC, Sound Processor, YM2151	5010-09034-00	R14 - R17	Resistor, 10K, 1/4w, 5%
a) 5700-09004-00		Socket, IC, 24-pin (U3)	5010-09324-00	R6, R38	Resistor, 27K, 1/4w, 5%
5400-10320-00	U8	IC, μ Processor, MC6809E	5010-09162-00	R39	Resistor, 100K, 1/4w, 5%
a) 5700-08985-00		Socket, IC, 40-pin (U8)	5010-10258-00	R40	Resistor, 1M, 1/4w, 5%
A-5343-573-5	U4	IC, Audio ROM 1	5010-09179-00	R10	Resistor, 3.3M, 1/4w, 5%
A-5343-573-6	U19	IC, Audio ROM 2	5010-09534-00	W9	Resistor, 0 Ω , 1/4w, 5%
a) 5700-10176-00		Socket, IC, 28-pin (U4, U19)	5040-09343-00	C1, C3, C4, C8	Capacitor, 10 μ fd, 20v, \pm 20%
5371-09152-00	U11	IC, D/A Convtr, MC1408	5040-10974-00	C12, C19, C24	Capacitor, 100 μ fd, 35v
5430-10322-00	U12	IC, PIA, MC68B21	5040-09776-00	C26, C30	Capacitor, 470 μ fd, 16v; +50, -10%
5340-10139-00	U5	IC, RAM/S 5516-2 2Kx8	5040-12006-00	C29, C32	Capacitor, 1000 μ fd, 16v, 20%
5281-09487-00	U16	IC, Dual D Flipflop, 74LS74	5041-09243-00	C25, C28	Capacitor, 10 μ fd, 10v, \pm 10%
5281-10043-00	U13	IC, 74LS175	5043-08980-00	C5, B (17)*	Capacitor, 0.01 μ fd, 50v, +80, -20%
5281-09235-00	U21	IC, Triple NAND, 74LS10	5043-08996-00	C31, C33	Capacitor, 0.1 μ fd, 50v, \pm 20%
5370-09321-00	U9, U10, U17	IC, Op Amp, MC1458	5043-09065-00	C13 - C15	Capacitor, 470 pfd, 50v, \pm 20%
5281-09215-00	U2	IC, Hex Inv, 74LS04	5043-09492-00	C2, C34	Capacitor, 100 pfd, 50v, \pm 10%
5281-09246-00	U14	IC, 2-4 Dec, 74LS139	5043-09844-00	C6	Capacitor, 47 pfd, 50v, \pm 20%
5281-09745-00	U15	IC, Dual Mux, 74LS138	5043-09845-00	C16, C18, C20 - C23, C27	Capacitor, 1000 pfd, 50v, \pm 20%
5370-09156-00	U22, U23	IC, Audio Amp, TDA2002	5520-09020-00	X1	Crystal, 3.58 MHz
a) 5705-09199-00		Heatsink, #60308	5521-10931-00	CR1	Oscillator, 8 MHz
b) 4006-01003-06		Mach. Screw, 6-32 x 3/8	5551-09822-00	L1 - L3	Inductor, 4.7 μ H, 3A
c) 4406-01117-00		Nut, 6-32 Hex.	5791-09437-00	J4	Connector, 20 pin, (Hdr), Rib, Cbl
d) 4703-00007-00		Lockwasher, #6 Ext.	5791-10862-04	J1, J2, J5	Connector, 4 pin (Hdr)
5160-10269-00	Q1	Transistor, 2N3904, NPN	5791-10862-06	J3	Connector, 6 pin (Hdr)
5060-10396-00	SP1	SIP 4.7K & 470pfd, 8R8C	16-8850-250		P.C.B. I.D. Label
5010-09181-00	R44, R48	Resistor, 1.0 Ω , 1/2w, 5%	20-9229		Thermal Compound
5010-09161-00	R35, R45	Resistor, 2.2 Ω , 1/4w, 5%			
5010-09361-00	R43, R46, R47	Resistor, 220 Ω , 1/2w, 5%			
5010-09358-00	R41, R42	Resistor, 1K, 1/4w, 5%			

NOTES:

- 17 capacitors (shown on diagram with "B" symbol) provide +5VDC filtering for ICs.
- All capacitors are ceramic, 50v, axial, unless otherwise noted.
- All resistors are 5%, 1/4w, Carbon Film, unless otherwise noted.

SYSTEM 11B CPU BOARD D-11883-573

Item	Part Number	Ckt Designator	Description	Item	Part Number	Ckt Designator	Description
1	5764-12206-00		Bare P. C. Board	62	5010-10003-00	R62, R63	Resistor, 390Ω, 5%, 1/4w, C. F.
2	5370-08991-00	U3	IC, CVSD Mod., 55836	63	5010-10171-00	R67	Resistor, 562Ω, 5%, 1/4w, C. F.
3	5370-09021-00	U4, U5	IC, Dual Op Amp, 1458	64	5010-10170-00	R69	Resistor, 470Ω, 5%, 1/4w, C. F.
4	5281-09309-00	U16	IC, Octal Bus Xovt, 74LS245	65	5010-09160-00	R59, R61, W12, W13	Resistor, 220Ω, 5%, 1/4w, C. F.
5	5430-08972-00	U9, U10, U38, U41, U42, U51, U54	IC, PIA, MC6820/6821	66	5010-09416-00	R33, R34, R71-R78, R125-R137	Resistor, 470Ω, 5%, 1/4w, C. F.
6	5340-10139-00	U29	IC, 2K x 8 CMOS Static RAM	67	5010-09179-00	R9	Resistor, 33MΩ, 5%, 1/4w, C. F.
7	5280-09010-00	U44	IC, 4-16 Decoder, 74154	68	Not Used		
8	5281-09246-00	U7, U8, U12	IC, 2-4 Decoder, 74LS139	69	5010-10031-00	R111, R114, R117, R120, R123, R126, R129, R13	Resistor, 1.2KΩ, 5%, 1/2w, C. F.
9	5075-09406-00	ZR3 - ZR8	Diode, Zener, 6.2v, 0.5w	70	Not Used		
10	5164-10938-00	Q42 - Q49	Transistor, NPN, 2N5550, TO-92	71	Not Used		
11	5281-09487-00	U8	IC, Dual D Flip-Flop, 74LS74	72	5010-09120-00	R17	Resistor, 270KΩ, 5%, 1/4w, C. F.
12	5431-09449-00	U43	IC, Timer, MC1455	73	5010-09333-00	R15, R16, R18	Resistor, 180KΩ, 5%, 1/4w, C. F.
13	5310-09238-00	U29	IC, 14-b Counter, 40200	74	5010-09324-00	R29, R30	Resistor, 27KΩ, 5%, 1/4w, C. F.
14	5281-09743-00	U32	IC, Quad 2-Input AND, 74LS08	75	5010-09289-00	R20, R21	Resistor, 12KΩ, 5%, 1/4w, C. F.
15	5281-09247-00	U14	IC, Quad 2-Input NOR, 74LS02	76	5010-09356-00	R27, R28	Resistor, 600Ω, 5%, 1/4w, C. F.
16	5281-09235-00	U35	IC, Triple 3-Input NAND, 74LS10	77	5019-09783-00	SR18	SIP, 9R, 10-pin, 8.8KΩ, 125wR, 5%
17	5280-09013-00	U36	IC, Hex Inverter, 7404	78	5019-09362-00	SR3, SR15, SR17, SR19, SR20	SIP, 9R, 10-pin, 4.7KΩ, 125wR, 5%
18	5281-09499-00	U31, U34	IC, Quad 2-Input NAND, 74LS00	79	5019-09800-00	SR4, SR6, SR11	SIP, 9R, 10-pin, 500Ω, 125wR, 5%
19	5281-10014-00	U33	IC, Dual 4-Input NAND, 74LS20	80	5019-09785-00	SR16	SIP, 9R, 10-pin, 2.2KΩ, 125wR, 5%
20	5281-09486-00	U28	IC, Octal D Flip-Flop, 74LS374	81	5019-10472-00	SR14	SIP, 9R, 10-pin, 3.3KΩ, 125wR, 5%
21	5371-09152-00	L2	IC, D/A Converter, MC1408	82	5019-09669-00	SR8	SIP, 9R, 10-pin, 1.0KΩ, 125wR, 5%
22	5281-09745-00	U37	IC, 3-8 Decoder, 74LS138	83	5019-09780-00	SR9, SR10	SIP, 4R, 8-pin, 1KΩ, 5%
23	5340-09878-00	U25	IC, 2K x 8 Static RAM, 2016	84	5019-09788-00	SR1, SR2	SIP, 5R, 6-pin, 4.7KΩ, 125wR, 5%
24	Not Used			85	5019-09792-00	SR5, SR7	SIP, 9R, 10-pin, 2.7KΩ, 125wR, 5%
25	5281-09867-00	U11, U13, U40	IC, Octal Buffer, 74LS244	86	5020-10398-00	SRC1 - SRC5, SRC7 - SRC9	SIP, 8R, 8C, 10-pin, 4.7KΩ & 470pfd
26	5280-09773-00	U17-U20, U52, U53	IC, Quad 2-Input AND, 7408	87	5010-08774-00	R22	Resistor, 22KΩ, 5%, 1/4w, C. F.
27	5280-09774-00	U55, U56	IC, Hex Inverter, 7406	88	5043-08980-00	C14, C17-C21, C31, C32, C49-C56, C59, + 54 Bypass, marked B	Capacitor, 0.01 μfd, 50v(±20%), Axial
28	5310-09155-00	U30, U39	IC, Quad 2-Input NAND, MC14011	89	5043-09845-00	C22, C23, C25, C27, C28	Capacitor, 1K pfd, 50v(±20%), Axial
29	5280-09848-00	U45, U50	IC, Quad 2-Input NOR, 7402	90	5043-06998-00	C8, C70-75, C77, C78	Capacitor, 0.1 μfd, 50v(±20%), Axial
30	5280-09309-00	U49	IC, Hex Buffer, 7407	91	5040-09343-00	C8, C15	Capacitor, 10 μfd, Electr., 20v(±20%), Axial
31	5671-09019-00	LED1-LED3	LED, Red, Display	92	5043-09844-00	C7	Capacitor, 47 pfd, 50v(±20%), Axial
32	5621-10506-00	CR1	Oscillator, 4 Mhz	93	5040-10974-00	C24, C26, C29	Capacitor, 100 μfd, Electr., 25v(±50-10%), Axial
33	5162-08976-00	Q51, Q53, Q55, Q57, Q59, Q61, Q63, Q65, Q52, Q54, Q56, Q58, Q60, Q62, Q64, Q66	Transistor, NPN Darl, 2N6427, TO-92	94	Not Used		
34	5191-08976-00	Q68, Q69, Q14-Q17, Q22-Q26, Q30-Q33, Q69, Q71, Q73, Q75, Q77, Q79, Q80-Q87	Transistor, PNP, TIP42, TO-220	95	5045-09796-00	C60-C67	Capacitor, 0.1 μfd, Polycarbonate Rad., 100v(±10%)
35	5162-09410-00	Q2-C5, Q10-Q13, Q18-Q21, Q28-Q29, Q34-Q38, Q41, Q67, Q68, Q70, Q72, Q74, Q76, Q78	Transistor, NPN, TIP122, TO-220	96	5043-09065-00	C30-C40, C68, C69, C76, C10, C12	Capacitor, 470 pfd, 50v(±20%), Axial
36	5163-08938-00	Q1, Q40	Transistor, NPN, 2N3904, TO-92	97	5040-09545-00	C30	Capacitor, 22 μfd, Electr., 10v(±50-10%), Axial
37	5160-10269-00	Q39, Q50	Transistor, PNP, 2N4403, TO-92	98	5041-09031-00	C58	Capacitor, 1 μfd, Tert., 25v(±20%), Axial
38	5190-09016-00	S1-S8	SCR, 30v, 0.8A, 2N5060	99	5043-09030-00	C16, C57	Capacitor, 0.047 μfd, 50v(±20%), Axial
39	5130-09014-00	D3-D19	Diode, 1N4001	100	Not Used		
40	5070-06258-00	D2	Diode, 1N4148, 100mA	101	5043-09492-00	C11	Capacitor, 100 pfd, ceramic, 100v(±20%)
41	5070-09919-00	D1	Diode, 1N5817, 1.0A	102	Not Used		
42	5070-09266-00	ZR1	Diode, Zener, 1N5995A, 6.8v, 0.5w	103	5048-10992-00	C13	Capacitor, 4700 pfd, ceramic, 50v(±10%)
43	5075-09018-00	ZR2	Diode, Zener, 1N5990, 3.9v, 0.5w	104	5651-09622-00	L1-L3	Inductor, 4.7 μH, 3A
44	5075-09059-00	R94, R97, R100, R103, R106, R109	Resistor, 500Ω, 5%, 1/4w, C. F.	105	5641-09853-00	SW1, SW2	Switch, Pushbutton, DPDT, 100v, 5A
45	5010-08992-00	R56	Resistor, 10Ω, 5%, 1/4w, C. F.	106	5680-09022-00	B1-B3	Battery, Alkaline, 1.5v, AA
46	5010-09039-00	W1, W2, W4, W5, W7, W8, W11, W14, W16, W17, W19	Resistor, 0Ω, 5%, 1/4w, C. F.	107	20-9491	W19, W19	Bus Wire, Jumper
47	5010-09534-00	R31, R32, R35, R52, R56, R68, R92, R148	Resistor, 4.7KΩ, 5%, 1/4w, C. F.	108	5681-09021-00	Battery Holder, #171	Battery Holder, #171
48	5010-08991-00	R54, R57, R58, R64, R66, R138-R145	Resistor, 1.5KΩ, 5%, 1/4w, C. F.	109	5700-10179-00	a) A-5343-573-1 b) A-5343-573-2 c) A-5343-573-3 d) A-5343-573-4	IC Socket, 28 pin IC, Game ROM 2, 27128 IC, Game ROM 1, 27256 IC, Sound ROM 2, 27256 IC, Sound ROM 1, 27256 IC Socket, 40 pin
49	5010-09358-00	R79	Resistor, 33KΩ, 5%, 1/4w, C. F.	110	5700-08985-00	U15	IC, μProcessor, 6802
50	5010-09113-00	R17, R8, R10, R70, R80	Resistor, 3.3KΩ, 5%, 1/4w, C. F.	111	5400-09150-00	U24	IC, μProcessor, 6802
51	5010-08983-00	R11-R14, R25, R26, R53, R65, R85, R90	Resistor, 10KΩ, 5%, 1/4w, C. F.	112	5824-09248-00	TP1, TP2	Test Point
52	5010-09034-00	R81	Resistor, 6.8KΩ, 5%, 1/4w, C. F.	113	115	Not Used	
53	5010-09086-00	R3	Resistor, 5.8KΩ, 5%, 1/4w, C. F.	114	20-9229		Thermal Compound
54	5010-09363-00	R23, R24, R81, R93, R96, R98, R102, R105, R108, R112, R115, R118, R121, R124, R127, R130, R133	Resistor, 2.7KΩ, 5%, 1/4w, C. F.	115	5580-08994-01	K1	Relay, 4-pole, 400, 6v
55	5010-08997-00	R113, R116, R119, R122, R125, R128, R131, R134	Resistor, 0.4Ω, 5%, 3w, Wire-Wnd.	116	5791-10862-09	1J1, 1J2, 1J4-1J8, 1J10-1J12, 1J17-1J19	Connector, 9 pin (Hd)
56	5012-09037-00	R36-R51, R95, R98, R101, R104, R107, R110	Resistor, 68Ω, 5%, 1/2w, C. F.	117	5791-10862-04	1J13, 1J14, 1J16	Connector, 4 pin (Hd)
57	5010-08993-00	R82-R89	Resistor, 27Ω, 5%, 2w, C. F.	118	5791-10862-12	1J3	Connector, 12 pin (Hd)
58	5012-10860-00			119	5791-10862-04		Connector, 4 pin (Hd)
59	Not Used			120	5791-10862-12		Connector, 12 pin (Hd)
60	Not Used			121	Not Used		
61	5010-10987-00	R19	Resistor, 56KΩ, 5%, 1/4w, C. F.	122	5791-10862-00	1J22	Connector, 26 pin Ribbon (Hd)
				123	5791-09437-00	1J21	Connector, 20 pin Ribbon (Hd)

NOTES:

- For Schematic, refer to drawing #16-9019.
- Items 56 and 58 (resistors) must be mounted 1/8" above PCB surface.
- Standard Jumper: W1, W2, W4, W5, W7, W8, W11, W14, W16, W17, W19.

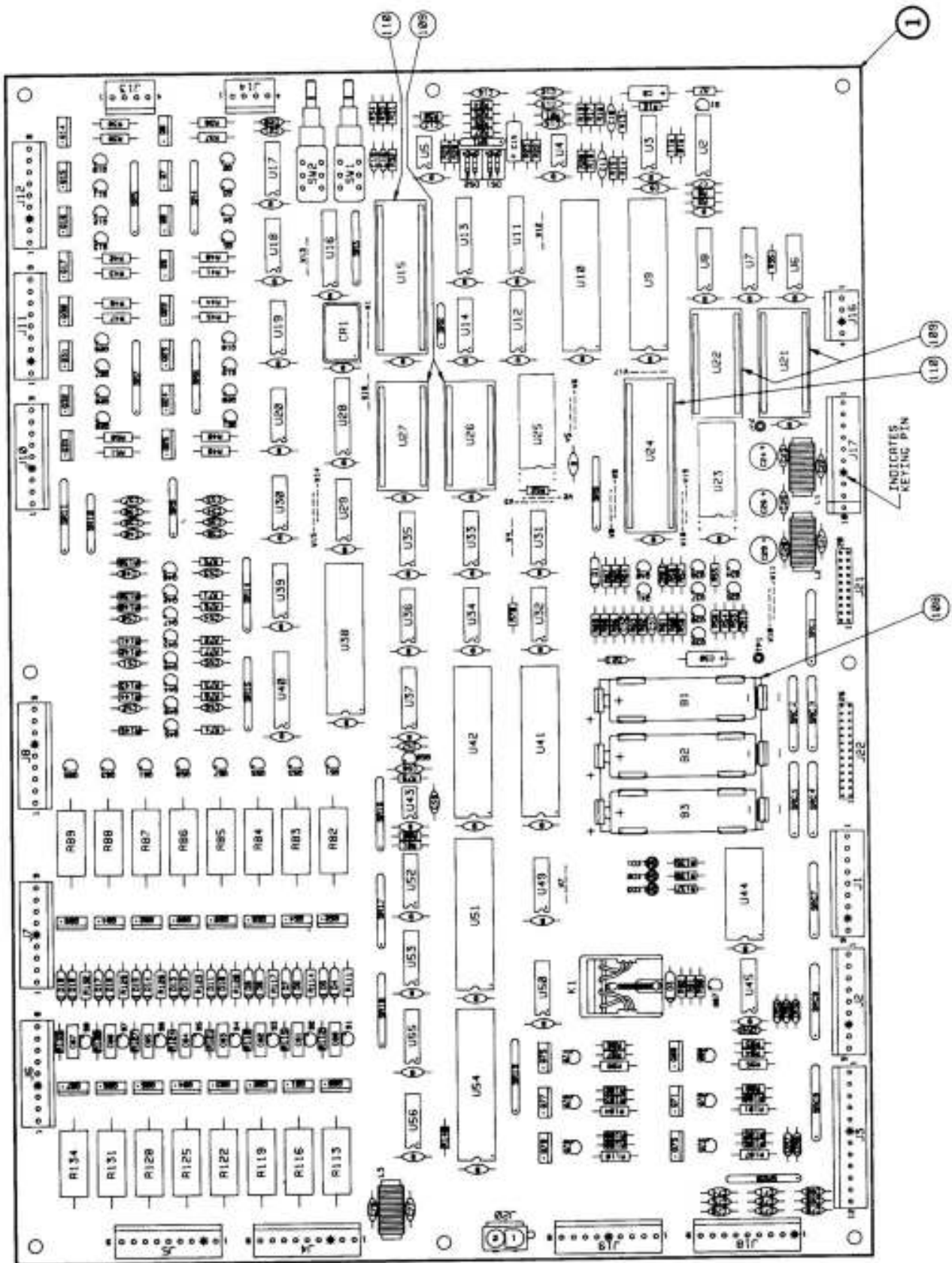

SYSTEM 11B CPU BOARD (D-11883)

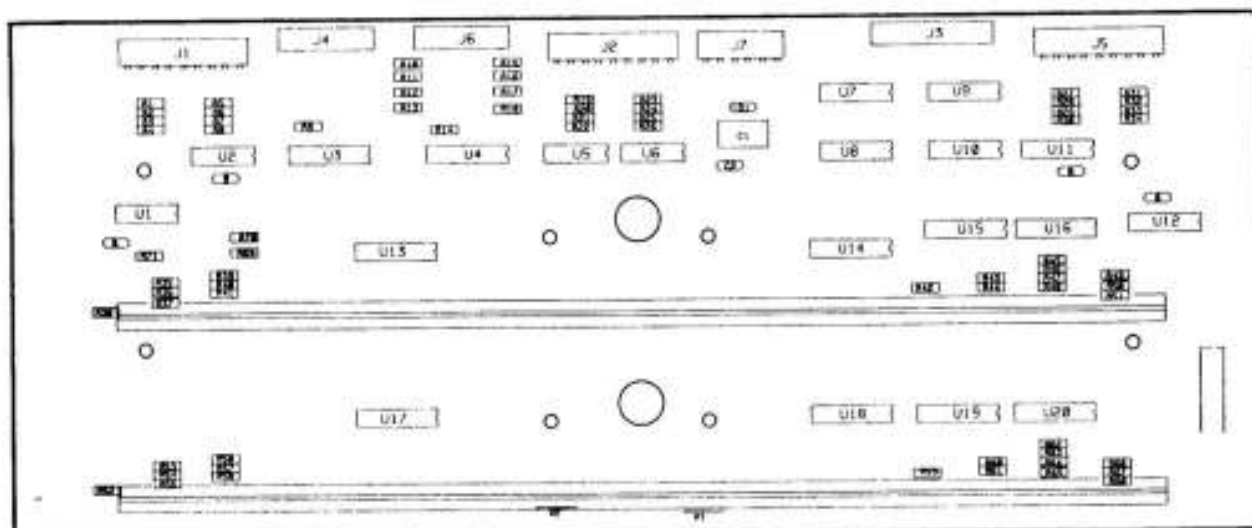

MASTER DISPLAY BOARD D-12232-2

Part Number	Ckt Designator	Description
5760-12306-00		Bare P.C. Board
5670-12308-00	DSPL1, DSPL2	Display, 16-Character, A/N
5310-09882-00	U1, U2, U5, U6	I.C. 4001
5310-08975-00	U7 - U12	I.C. 4049
5680-08968-00	U3, U13, U14, U17, U18	I.C. 6184, Anode Driver
5680-08969-00	U15, U16, U19, U20	I.C. 7180, Cathode Driver
5040-09343-00	C1	Axial Cap, 10 μ fd, 20v, \pm 20%
5043-08980-00	Bypass	Axial Cap, 0.01 μ fd, 50v, +80, -20%
5075-09135-00	D1, D2	Zener, 1N4740A, 10v, 1w
5791-10869-09	J1, J2, J5	9-pin Header, Rt. Angle
5791-10869-06	J7	6-pin Header, Rt. Angle
5791-09438-00	J4	20-pin Header, Rt. Angle
5791-10851-00	J3	26-pin Header, Rt. Angle
5010-09534-00	W1, W2	Resistor, 0 Ω
5010-08773-00	R1-R8, R19-R35, R41, R43, R45, R71	Resistor, 18K Ω , 1/4w, 5%
5010-10258-00	R9, R38, R52, R69	Resistor, 1M Ω , 1/4w, 5%
5010-10927-00	R36, R39, R40, R42, R47, R48, R50, R51, R59, R68	Resistor, 8.2K Ω , 1/2w, 5%
5010-08981-00	R10-R13, R15-R18, R37, R44, R46, R49 R53, R55, R58, R61, R63, R66	Resistor, 10K Ω , 1/2w, 5%
03-8088-1	Support	Support, Display
16-8850-232		PCB Label
23-6634		Cover, Display

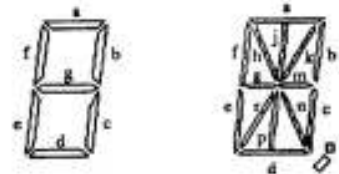
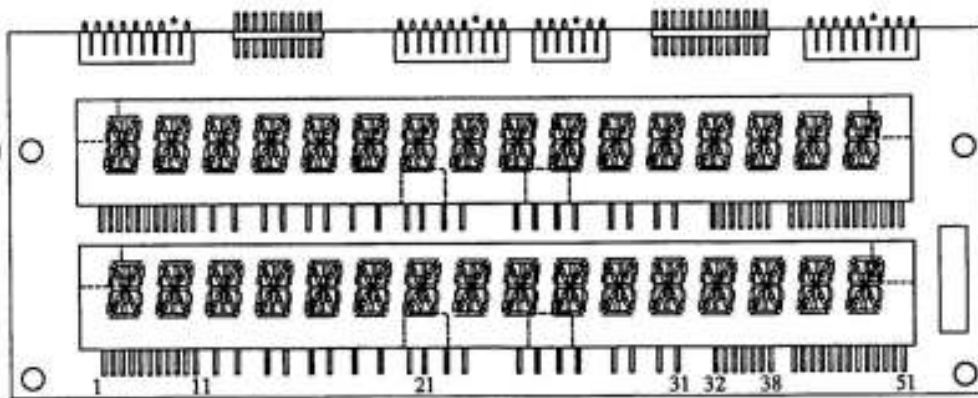

DISPLAY CHARACTERS
SEGMENT DESIGNATIONS

16-CHARACTER DISPLAY GLASS
p/n 5670-12308-00

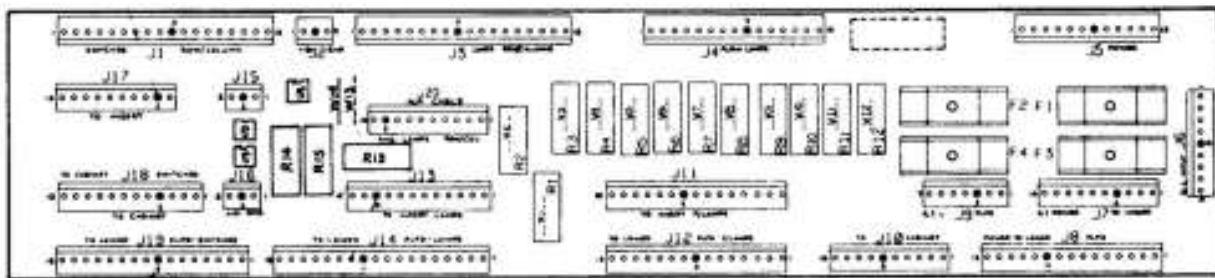

BACKBOX INTERCONNECT BOARD
D-12313-573

Part Number	Ckt Designator	Description
5768-12332-00		Master Interconnect Board
5010-09534-00	W12, W13	Resistor, 0Ω
5012-12238-00	R14, R15	Resistor, 3.3KΩ, 5w, 10%
5012-12337-00	R13	Resistor, 1.5KΩ, 5w, 10%
5012-12456-00	R1 - R11	Resistor, 1.5Ω, 5w, 10%
5490-10892-00	U1 - U3	Opto Isolator 4N25
5731-09651-00	F1-F4	Fuse, 5A.S.B., 250v
5733-12060-01		Fuse Holder, F1-F4
5791-10862-03	J2, J16	Connector, 3-pin Hdr Sq Pin .156
5791-10862-07	J9	Connector, 7-pin Hdr Sq Pin .156
5791-10862-09	J6	Connector, 9-pin Hdr Sq Pin .156
5791-10862-10	J7, J10, J20	Connector, 10-pin Hdr Sq Pin .156
5791-10862-12	J5, J13, J18	Connector, 12-pin Hdr Sq Pin .156
5791-10862-15	J8	Connector, 15-pin Hdr Sq Pin .156
5791-10862-16	J4, J11, J12, J19	Connector, 16-pin Hdr Sq Pin .156
5791-10862-18	J1, J3, J14	Connector, 18-pin Hdr Sq Pin .156
16-8850-257		PCB Label

**LAMP BOARD ("3-L")
C-12709**

Part Number	Description
5768-12409-00	PC Board
24-8767	Twist Lamp Socket
24-8768	Bulb, #555 (6.3v, .25 A.)
5070-09054-00	Diode, 1N4004, 1.0 A.
5791-10871-05	Header, 5-pin sq post

**LAMP BOARD ("3-R")
C-12710**

Part Number	Description
5768-12410-00	PC Board
24-8767	Twist Lamp Socket
24-8768	Bulb, #555 (6.3v, .25A.)
5070-09054-00	Diode, 1N4004, 1.0 A.
5791-10871-05	Header, 5-pin sq post

**LAMP BOARD ("1")
B-12224**

Part Number	Description
5768-12312-00	PC Board
24-8767	Twist Lamp Socket
24-8768	Bulb, #555 (6.3v, .25A.)
5070-09054-00	Diode, 1N4004, 1.0 A.

**LAMP BOARD ("6-L")
C-12711**

Part Number	Description
5768-12411-00	PC Board
24-8767	Twist Lamp Socket
24-8768	Bulb, #555 (6.3v, .25A.)
5070-09054-00	Diode, 1N4004, 1.0 A.
5791-10871-08	Header, 8-pin sq post

**LAMP BOARD ("6-C1")
C-12712**

Part Number	Description
5768-12412-00	PC Board
24-8767	Twist Lamp Socket
24-8768	Bulb, #555 (6.3v, .25A.)
5070-09054-00	Diode, 1N4004, 1.0 A.
5791-10871-08	Header, 8-pin sq post

**LAMP BOARD ("6-C2")
C-12713**

Part Number	Description
5768-12413-00	PC Board
24-8767	Twist Lamp Socket
24-8768	Bulb, #555 (6.3v, .25A.)
5070-09054-00	Diode, 1N4004, 1.0 A.
5791-10871-08	Header, 8-pin sq post

**RELAY BOARD
(SOL. 10 & 11 GEN. ILLUM)
C-11998-1**

Part Number	Description
5768-12243-00	PC Board
5070-09054-00	Diode, 1N4004, 1.0 A. (D1)
5580-09555-01	Relay, 24vdc, 30A (K1)
5010-09534-00	Resistor, 0Ω (W1, W2)
5791-12273-02	Header, 2-pin sq post (J1)
5791-12273-07	Header, 7-pin sq post (J2)

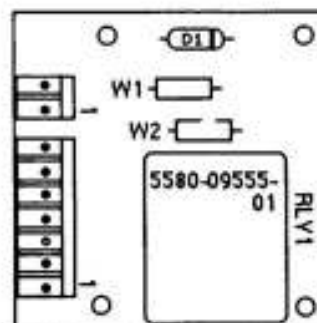

**LAMP BOARD ("3-C")
C-12000**

Part Number	Description
5768-12245-00	PC Board
24-8767	Twist Lamp Socket
24-8768	Bulb, #555 (6.3v, .25 A.)
5070-09054-00	Diode, 1N4004, 1.0 A.
5791-10871-05	Header, 5-pin sq post

**TOP LIGHT LAMP BD
C-12717
(Left & Right)**

Part Number	Description
5768-12414-00	PC Board
24-8803	Twist Lamp Socket
24-8802	Bulb, #906 (13v, .69 A.)
24-8767	Twist Lamp Socket
24-8768	Bulb, #555 (6.3v, .25 A.)
5791-10871-05	Header, 5-pin sq post

**CITY JAIL LAMP BOARD
C-12716**

Part Number	Description
5768-12415-00	PC Board
24-8767	Twist Lamp Socket
24-8768	Bulb, #555 (6.3v, .25 A.)
5070-09054-00	Diode, 1N4004, 1.0 A.
5791-10871-066	Header, 6-pin sq post

**FIRING RANGE LAMP BD
C-12698**

Part Number	Description
5768-12402-00	PC Board
24-8767	Twist Lamp Socket
24-8768	Bulb, #555 (6.3v, .25 A.)
5070-09054-00	Diode, 1N4004, 1.0 A.
5791-10871-07	Header, 7-pin sq post

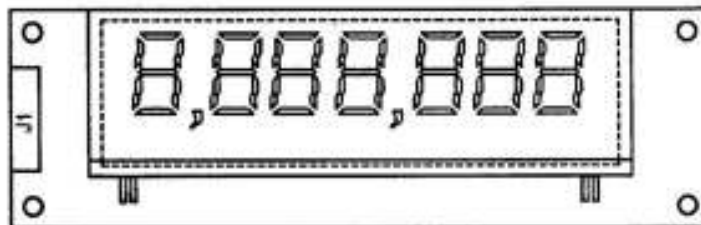

**SLAVE DISPLAY ASSEMBLY
C-8364-1**

Item	Part Number	Ckt Designator	Description
1	5762-10933-00		PCB Slave Display
2	23-6545		Foam Display - Back
3	5670-09439-00		Display 7-Digit Glass
4	5791-09438-00	J1	20 HCN 2 x 10 Rt. Angle
5	23-6546		Foam Display - Front

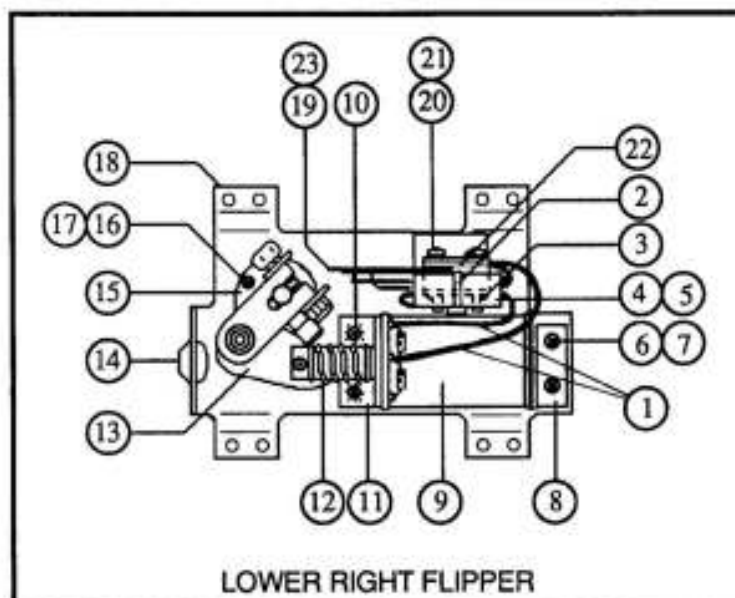

**LOWER RIGHT FLIPPER
C-11626-R-3**

Item	Part Number	Description	Item	Part Number	Description
1	HW-30018-6	Wire, 18 AWG, Blue	19	06-14G	Insulating Blade
2	03-7520-2	Ty-Wrap, Nylon	20	4105-01019-10	Sh. Metal Screw, #5 x 5/8
3	20-6516	Speednut, Tinnerman	21	4701-00002-00	Lockwasher, #6 Split
4	5045-12098-00	Capacitor, 2.2 µFd, 250V, 20%	22	23-6622	Tape, Double-sided
5	RM-21-06	Sleeve, Vinyl (Cap. leads)	23	03-7811	End of Stroke (EOS) Switch
6	4010-01066-06	Cap Screw, 10-32 x 3/8, SH	** - Also See Separate Diagram		
7	4701-00004-00	Lockwasher, #10 Split			
8	A-12111	Flipper Stop Assembly			
9	FL-11630	Flipper Coil (Red), (* - Refer to Note 3)			
10	4006-01017-04	Mach. Screw, 6-32 x 1/4, P-RH-S			
11	01-7695	Solenoid Bracket			
12	10-376	Coil Plunger Spring			
13	B-10655-R	Crank Link Assembly, Right			
a)	02-4179	Link Spacer Bushing			
b)	4010-01086-14	Cap Screw, 10-32 x 7/8, SH			
c)	4700-00023-00	Washer, 5/8 o.d.x13/64 i.d.x16ga.			
d)	4701-00004-00	Lockwasher, #10 Split			
e)	4410-01132-00	Nut, 10-32 ESNA			
f)	A-10656**	Flipper Link Assembly			
1.)	02-4219	Coil Plunger			
2.)	20-9370-1	Spring Pin, 5/32 dia. x 7/16			
3.)	03-8050-1	Flipper Link			
g)	B-10657-R	Flipper Crank Assembly, Right			
1.)	01-8073-R	Flipper Crank, Right			
2.)	17-1037	Crank Washer			
3.)	4010-01066-18	Cap Screw, 10-32 x 1-1/8, HCS			
4.)	4410-01127-00	Nut, 10-32 Hex Hd.			
5.)	4700-00107-00	Washer, 5/8 o.d.x13/64 i.d. x 12ga.			
6.)	4701-00004-00	Lockwasher, #10 Split			
7.)	RM-23-06	Tubing, H. S. 1/4 DWP			
14	23-6577	Bumper Plug			
15	03-7568	Flipper Bushing			
16	4006-01005-06	Mach. Screw, 6-32 x 3/8, P-PH			
17	4406-01117-00	Nut, 6-32 Hex.			
18	C-11627-R	Flipper Base Assembly, R.			

Flipper Assembly Notes:

1. Each Flipper Assembly on the Lower Playfield is mounted beneath the playfield, in conjunction with the plastic Flipper Paddle and Shaft (20-9250-6) and flipper Rubber (23-6519-4) on the upper side of the playfield.
2. The tip of the EOS Switch must travel 0.0150 (+ .010, - .000) inch, before the contacts fully open, with the flipper in the actuated position. The EOS Switch contacts must have a gap of 0.062 (± .015) inch. Adjustment of the EOS Switch must be made at a minimum distance of 0.25 inch from the switch body.
3. All moving elements of the assembly must operate freely, with no evidence of binding.
4. The large end of the Coil Plunger Spring (item 12) must fit within the four lugs of the Solenoid Bracket.
5. For coil replacement, remove the Solenoid Bracket (item 11) to prevent screw damage.
6. Use Loctite™ 242 when reattaching screws to the Flipper Stop Assembly, the Solenoid Bracket, and the Flipper Bushing.
7. When replacing the Bumper Plug (item 14) to restore proper flipper operation, readjust the flipper paddle and shaft position.
8. Solid color blue wire connects to the banded end of each diode, mounted on the connector end of the Flipper Coil (item 9). Trace color wire connects to the unbanded end of the diode.

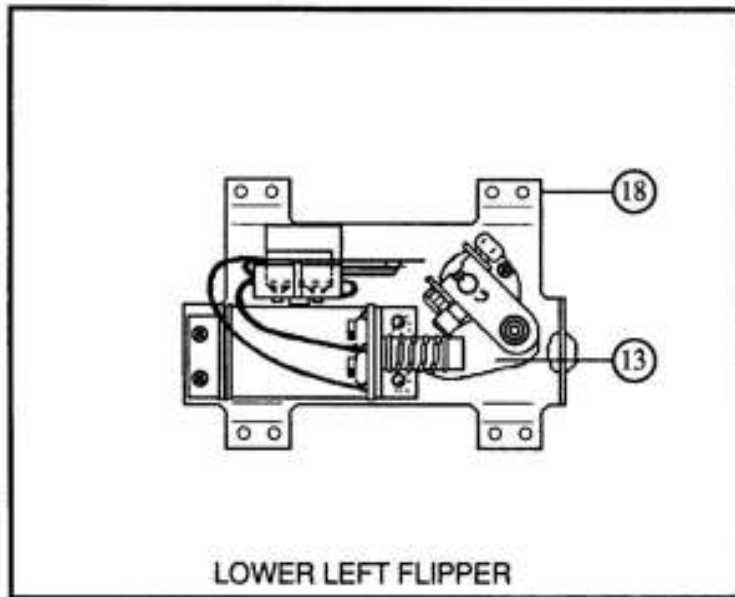

LOWER LEFT FLIPPER
p/n C-11626-L-3

(Parts listed replace same items of C-11626-R-3)

Item	Part Number	Description
13	B-10655-L	Crank Link Assembly, Left
g)	B-10657-L	Flipper Crank Assembly, Left
1.)	01-8073-L	Flipper Crank, Left
18	C-11627-L	Flipper Base Assembly, Left

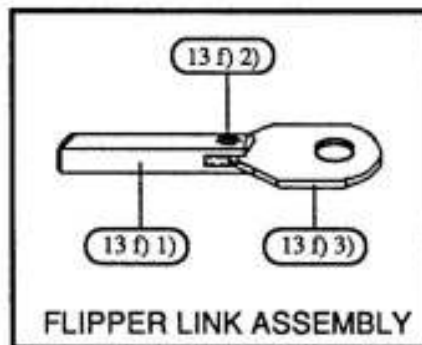

FLIPPER LINK ASSEMBLY
A-10656

Item	Part Number	Description
13 f) 1.)	02-4219	Coil Plunger
13 f) 2.)	20-9370-1	Spring Pin, 5/32 dia. x 7/16
13 f) 3.)	03-8050-1	Flipper Link

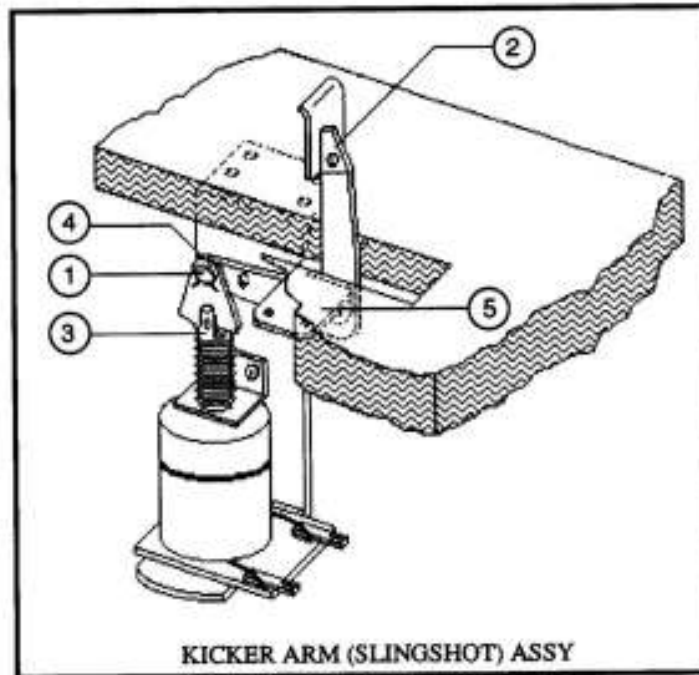

KICKER ARM (SLINGSHOT) ASSY

**KICKER ARM (SLINGSHOT) ASSEMBLY
B-12665
(Left & Right Kickers)**

Item	Part Number	Description
1	12-6227	Clip, Hairpin
2	A-12664	Kicker Crank Assembly
3	A-5103	Coil Plunger Assembly
a)	02-2364	Coil Plunger
b)	20-8716-5	Roll Pin, 1/8 x 7/16
c)	03-8085	Armature Link
4	4700-00030-00	Flatwasher, 17/64 o.d. x 1/2 i.d. x 15ga.
5	A-5653	Mounting Bracket Assy

ASSOCIATED PARTS FOR RIGHT KICKER

Part Number	Description
B-11203-L-1	Coil & Bracket Assembly
B-7572-1	Bracket & Stop Assembly
01-8-508-S	Coil Retaining Bracket
4006-01017-06	Mach. Screw, 6-32 x 3/8
4406-01119-00	Nut, 6-32 ESN
AE-26-1500	Coil Assembly
03-7066	Coil Tubing

ASSOCIATED PARTS FOR LEFT KICKER

Part Number	Description
B-11203-R-1	Coil & Bracket Assembly
B-7572-1	Bracket & Stop Assembly
01-8-508-S	Coil Retaining Bracket
4006-01017-06	Mach. Screw, 6-32 x 3/8
4406-01119-00	Nut, 6-32 ESN
AE-26-1500	Coil Assembly
03-7066	Coil Tubing

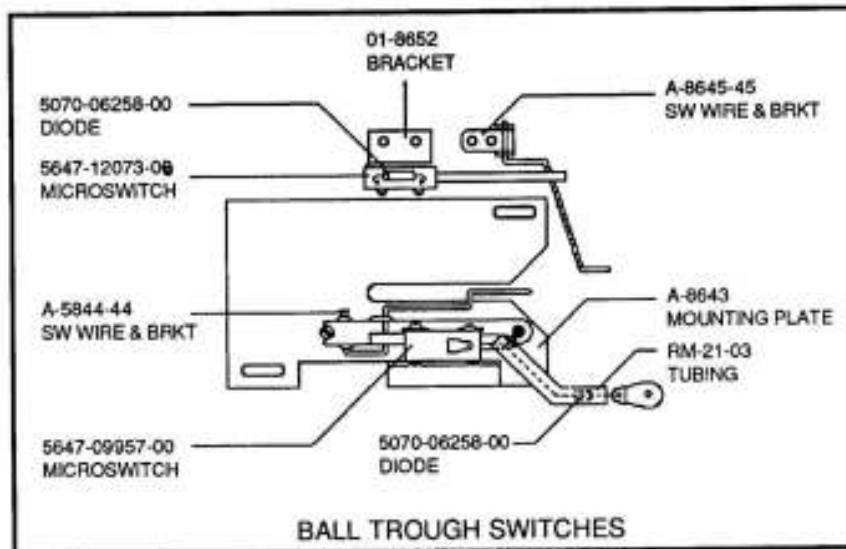

BALL TROUGH SWITCHES
(Viewed from underside of playfield to show locations)

Part Number	Description
B-8642-1	Ball Trough Switch Plate Assy
A-5844-44	Switch Wire & Bracket Assy
A-8641-1	Bracket & Mounting Plate Assy
5647-09957-00	μswitch; Cntr & L Ball Trough
4004-01060-08	Mach. Screw, 4-40 x 1/2
4005-01005-04	Mach. Screw, 5-40 x 1/4
5070-06258-00	Diode, 1N4001, 1.0A.
5825-09373-00	Solder Lug-Flat, #4
RM-21-03	Insulating Tubing, #10 x 1.75
A-11680	Ball Trough Switch, Right
5647-12073-08	Submin. Switch
5070-06258-00	Diode, 1N4001, 1.0A.
A-8645	Switch Wire & Bracket Assy

KNOCKER ASSEMBLY
B-10686-1

Item	Part Number	Description
1	A-5387	Coil Plunger Assembly
a)	02-2653	Coil Plunger
b)	03-6013	Bell Arm Ext.
2	B-7409-2	Mtg. Bracket Assembly
3	AE-23-800	Coil Sub-Assembly
4	01-8-508-T	Coil Retaining Bracket
5	23-6420	Rubber Grommet
6	4008-01017-06	Mach. Screw, 8/32 x 3/8
7	H-11835	Knocker Cable
8	03-7067-5	Coil Tubing

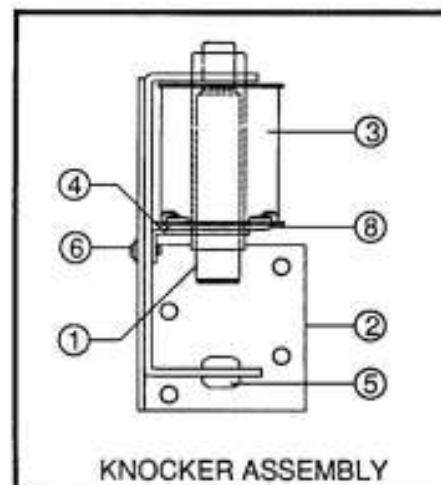

BALL SHOOTER LANE FEEDER C-9638-3

Item	Part Number	Description
1	12-6227	Clip, Hairpin
2	A-8247	Eject Cam Assy
3	10-362	Ejector Spring (Plain)
4	A-6949-L	Spring Plate Assy
5	A-8050-1	Coil Plunger Assy, 2-1/8
a)	02-3407-2	Coil Plunger, 2-1/8
b)	20-8716-5	Roll Pin, 1/8 x 7/16
c)	03-8085	Armature Link
6	4700-00030-00	Flat Washer, 17/64 x 1/2 x 15 ga
7	4700-00103-00	Flat Washer, 17/64 x 1/2 x 28 ga.
8	A-8268-2	Eject Cam Bracket Assembly

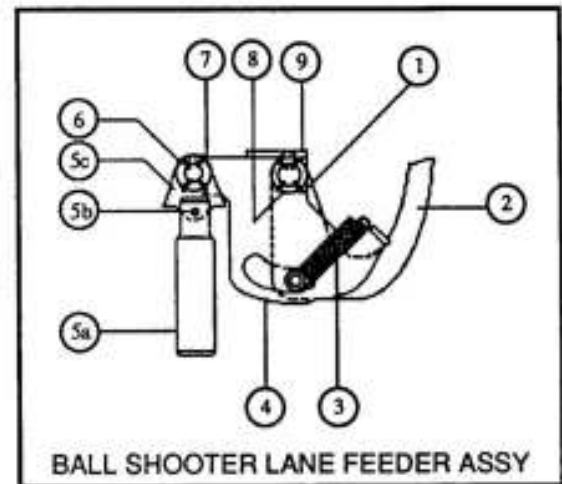

BALL SHOOTER LANE FEEDER ASSY

ASSOCIATED PARTS

B-9362-R-1	Coil & Bracket Assy
B-7572-1	Bracket & Stop Assy
01-8-508-S	Coil Retaining Bracket
4006-01017-06	Mach. Screw, 6-32 x 3/8
4406-01119-00	Nut, 6-32 ESN
AE-23-800	Coil Assembly
03-7066	Coil Tubing

OUTHOLE KICKER ASSEMBLY B-8039-2

Item	Part Number	Description
1	A-6378	Mounting Plate Assy
2	A-8335	Coil Plunger Assy
a)	02-2364	Coil Plunger
b)	20-8716-5	Roll Pin, 1/8 x 7/16
c)	01-4251	Ball Return Link
3	03-7066	Coil Tubing
4	A-6889	Kicker Lever Assy
5	A-8038	Coil Stop Assembly
6	AE-23-800	Coil Assembly
7	03-7176-1	Striker Ring
8	10-101-4	Spring-Reset
9	20-8712-25	"E" Ring, 1/4" Shaft
10	4006-01003-03	Mach. Screw, 6-32 x 3/16

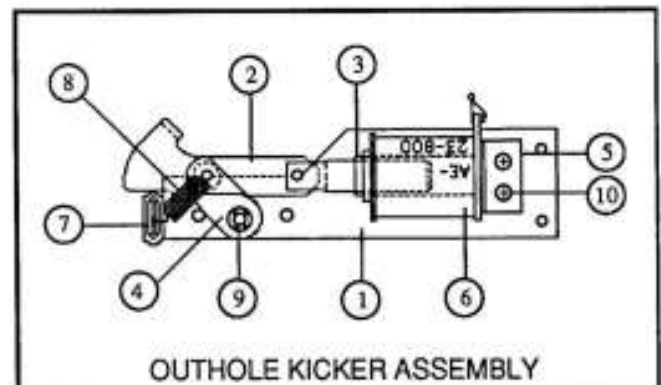

OUTHOLE KICKER ASSEMBLY

BR EJECT HOLE ARM ASSEMBLY B-9361-R-8

Item	Part Number	Description
1	A-6949-R	Spring Plate Assembly
2	A-8268	Mounting Bracket Assy
3	A-7471-R	Eject Cam Assembly
4	A-8050-1	Plunger Assembly, 2-1/8
5	10-362	Eject-Spring
6	12-6227	Hairpin Clip
7	4700-00030-00	Flatwasher, 17/64 x 1/2 x 15ga.
8	4700-00103-00	Flatwasher, 17/64 x 1/2 x 28ga.

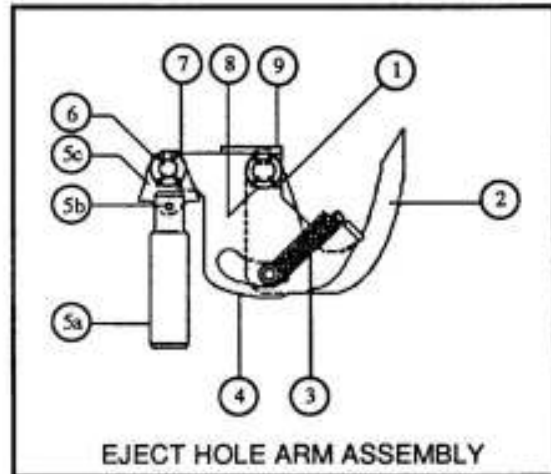

ASSOCIATED PARTS

B-9362-R-1	Coil & Bracket Assembly
B-7572-1	Bracket & Stop Assembly
01-8-508-S	Coil Retaining Bracket
4006-01017-06	Mach. Screw, 6-32 x 3/8
4406-01119-00	Nut, 6-32 ESN
AE-23-800	Coil Assembly
03-7066	Coil Tubing

TL EJECT HOLE ARM ASSY B-9361-R-6

Item	Part Number	Description
1	A-6949-R	Spring Plate Assembly
2	A-8268	Mounting Bracket Assy
3	A-7471-R	Eject Cam Assembly
4	A-8050	Plunger Assembly, 2-1/8
5	10-320	Eject-Spring (Red)
6	12-6227	Hairpin Clip
7	4700-00030-00	Flatwasher, 17/64 x 1/2 x 15ga.
8	4700-00103-00	Flatwasher, 17/64 x 1/2 x 28ga. 17/64x1/2x28ga.

ASSOCIATED PARTS

B-9362-R-1	Coil & Bracket Assembly
B-7572-1	Bracket & Stop Assembly
01-8-508-S	Coil Retaining Bracket
4006-01017-06	Mach. Screw, 6-32 x 3/8
4406-01119-00	Nut, 6-32 ESN
AE-23-800	Coil Assembly
03-7066	Coil Tubing

TR EJECT HOLE ARM ASSY B-9361-R-1

Item	Part Number	Description
1	A-6949-R	Spring Plate Assy
2	A-12960	Eject Cam Brkt. Assembly
3	A-7471-R	Eject Cam Assembly
4	A-8050-1	Plunger Assembly, 2-1/8
5	10-362	Eject-Spring
6	12-6227	Hairpin Clip
7	4700-00030-00	Flatwasher, 17/64x1/2x15ga.
8	4700-00103-00	Flatwasher,

ASSOCIATED PARTS

B-9362-L-1	Coil & Bracket Assembly
B-7572-1	Bracket & Stop Assembly
01-8-508-S	Coil Retaining Bracket
4006-01017-06	Mach. Screw, 6-32 x 3/8
4406-01119-00	Nut, 6-32 ESN
AE-23-800	Coil Assembly
03-7066	Coil Tubing

JET BUMPER ASSEMBLY B-9414-1

Item	Part Number	Description
1	A-4754	Bumper Ring Assy
2	03-6009-A5	Bumper Base-Wht
3	03-6035-1	Bumper Wafer-Blue
4	03-7443-5	Bumper Body-Wht
5	10-7	Spring-Jet Bumper
6	A-11199	Socket & Bulb Assy
a)	24-8768	Bulb #555, (6.3V, .25A.)
b)	24-8776	Wedge Base Socket
7	03-8254-6	Jet Cap - Yellow

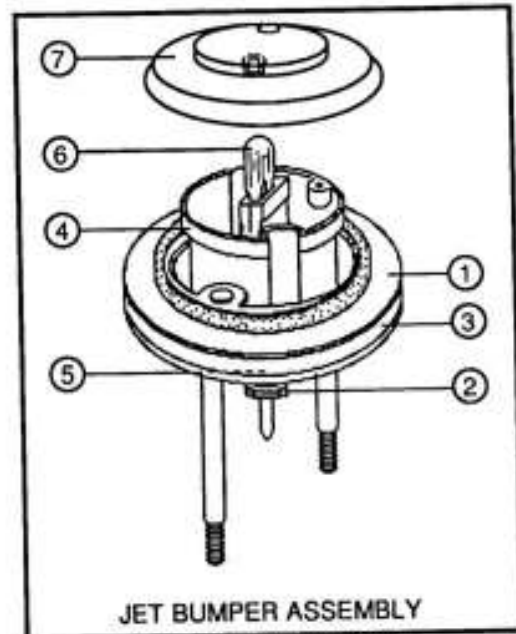

JET BUMPER COIL ASSY B-9415-1

Item	Part Number	Description
1	B-7417	Bracket & Stop Assy
2	01-1747	Coil Retaining Bracket
3	01-5492	Armature Link, Steel
4	01-5493	Armature Link, Bakelite
5	02-3406-1	Coil Plunger
6	10-326	Armature Spring
7	AE-23-800	Coil Assembly
8	4006-01017-04	Mach. Screw, 6-32 x 1/4
9	03-7066	Coil Tubing

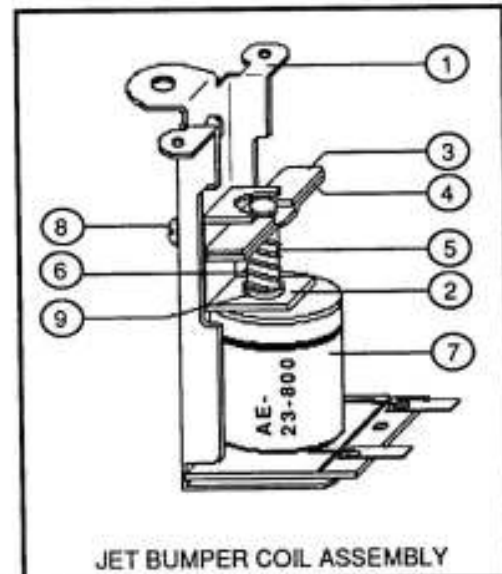

ASSOCIATED PARTS

B-12030-2	Jet Bumper Sw & Diode Assy
B-12029-2	Jet Bumper Sw & Brkt. Assy
SW-11A-37	Jet Bumper Switch Assy
01-1168	Mounting Brkt., Bumper Sw
01-3670	Switch Plate - Curved
03-7395	Switch Actuator
4005-01051-12	Mach. Screw, 5-40 x 3/4
4405-01117-00	Nut, 5-40 Hex.
5070-06258-00	Diode, 1N4001, 1.0 A.

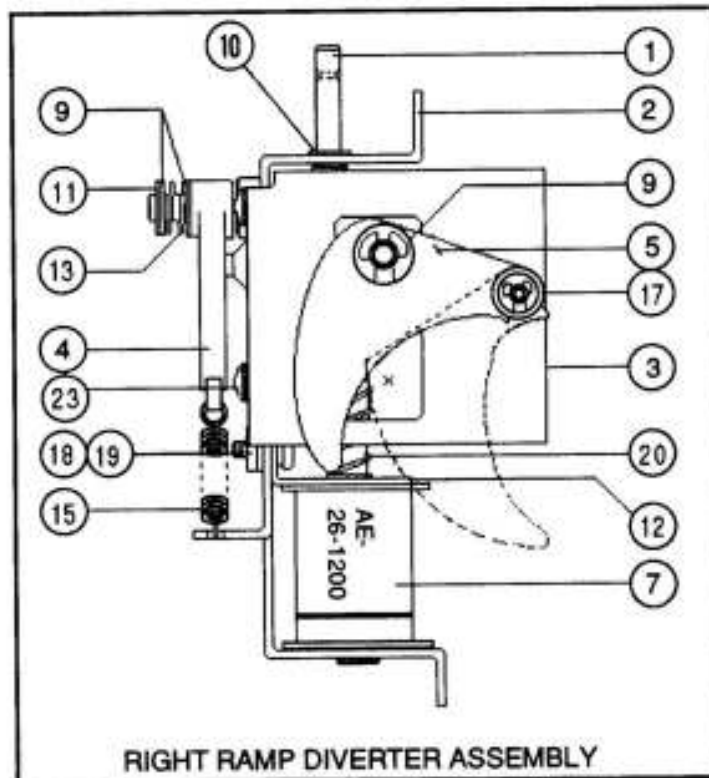

RIGHT RAMP DIVERTER ASSEMBLY C-12808

Item	Part Number	Description	Item	Part Number	Description
1	B-12901	Plunger Assembly	8	10-399	Compression Spring
a)	02-4302	Threaded Plunger	9	20-8712-25	"E" Spring, 1/4" Shaft
b)	4700-00060-00	Flatwasher, 7/32 x 1/2 x 16ga.	10	20-8790-7	Nylined Bearing
c)	4701-00004-00	Lockwasher, #10 Split	11	4700-00103-00	Flatwasher, 17/64x1/2x28ga.
d)	4410-01130-00	Nut, 10-32 Hex.	12	01-8413	Bracket Coil Mounting
e)	02-4306	2 P/Target Shaft	13	10-392	Compression Spring
f)	B-12810	Drive Arm Assembly	14	4002-01005-06	Mach. Screw, 2-56 x 3/8
1)	02-4304	Actuating Pin	15	10-401	Extension Spring
2)	01-9203	Bracket -Drive Arm	16	5070-06258-00	Diode, 1N4001, 1.0A
3)	4408-01119-00	Nut, # 8-32 ESN	17	20-8712-18	"E" Ring, 3/16" Shaft
4)	02-4369	Post - Drive	18	4701-00004-00	Lockwasher, #10 Split
2	B-12804	Lane Bracket Assembly	19	4010-01008-06	Mach. Screw, 10-32 x 3/8
3	B-12809	Pivot Post Bracket Assy	20	03-7066	Coil Tubing, 1-3/4
4	03-8090	Flat Cam - 2P Target	21	01-8600	Switch Insulator
5	03-8262	Cam - Lane Change	22	4701-00024-00	Lockwasher, #2 Split
6	5647-12073-06	Mini-Switch w/Roller	23	4008-01003-05	Mach. Screw, 8-32 x 5/16
7	AE-26-1200	Coil Assembly			

IDLER PULLEY ASSEMBLY B-12803

Item	Part Number	Description
1	B-12802	Pulley Bracket Assembly
a)	01-9200	Pulley Bracket
b)	02-4370	Post - Idler Pulley
2	03-8281	Pulley- Car
3	4700-00103-00	Flatwasher, 17/64 x 1/2 x 28ga.
4	20-8712-25	"E" Ring, 1/4" Shaft

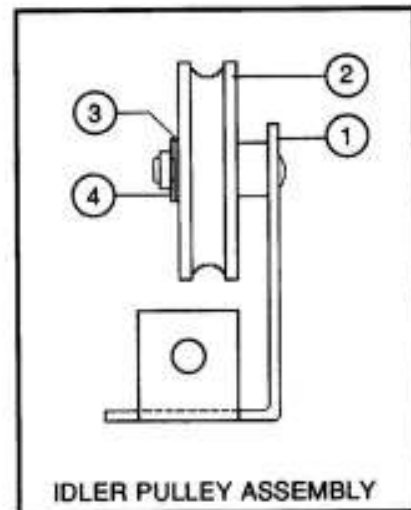

TRAVERSE BRACKET ASSEMBLY B-12800

Item	Part Number	Description
1	B-12801	Traverse Bracket / Nut Assy
a)	01-9198	Bracket - Traverse
b)	20-9497	PEM Nut, 8-32
2	01-9199	Clamp Belting
3	4008-01003-12	Mach. Screw, 8-32 x 3/4 P-PHS
4	4408-01128-00	Nut, 8-32 KEPS

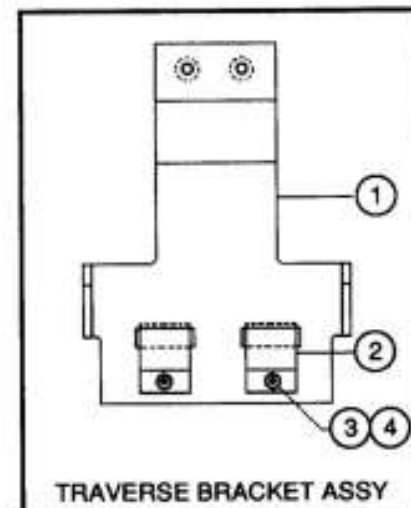

SPINNING TARGET ASSEMBLY B-12785

Item	Part Number	Description
1	B-12788	Spinning Tgt. Brkt. Flap Assy
2	B-12941	Spinning Target & Decal Assy
a)	B-12791	Shaft Target Assembly
b)	31-1510-573	Spin Target Decal
3	C-12946-1	Switch & Cable Assembly
a)	C-12946	Single Opto Sw. Assy
b)	H-12968	Opto - Switch Cable
4	01-9197	Bracket - Opto Switch Mtg.
5	03-8280	Interrupter - Opto
6	12-6866	Clip - Target Shaft
7	20-8712-12	"E" Ring, 1/8" Shaft
8	4006-01003-04	Mach. Screw, 6-32 x 1/4

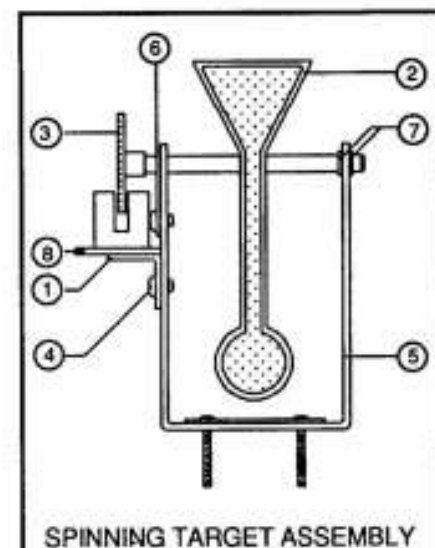

POLICE CAR ASSEMBLY B-12805

Item	Part Number	Description
1	21-6685	Car - Police
2	C-12678-1	Police Car LED- Cable Assy
a)	C-12678	Police Car LED-Cable Assy
b)	H-12971	Police Car Cable
3	20-9587	Spring Grip Retainer
4	B-12947	Car Chassis Assembly
a)	01-9190	Bracket, Car Chassis
b)	20-9496	PEM Nut, 6-32
5	4104-01012-04	Sh. Metal Screw, #4 x 1/4 P-PH
6	03-8303	Ball Stop Guide
7	4006-01003-14	Mach. Screw, #6-32 x 7/8
8	31-1498-573-H	Decal - Car
9	31-1498-573-J	Decal - Car
10	31-1498-573-K	Decal - Car
11	31-1498-573-L	Decal - Car
12	01-9298	Car Window Shield

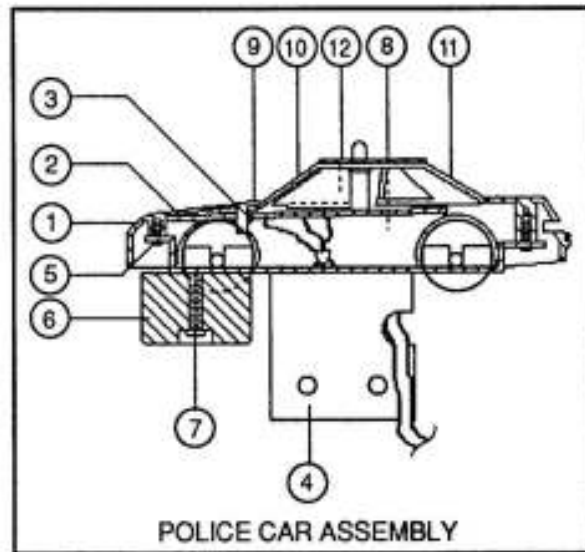

POLICE CAR LED ASSEMBLY C-12678

Item	Part Number	Ckt Designator	Description
1	5768-12400-00		Police Car Led PCB
2	5010-08930-00	R1 - R4	Resistor, 470Ω, 1/2w, 5%
3	5671-12403-00	LED 3, LED 4	LED, 1-3/4 Super Bright
4	03-8284-1		Spacer, LED (LED 3, LED 4)
5	5671-12404-00	LED 1, LED 2	LED Yellow, 1-3/4 Super Bright

CAR MOTOR BRACKET ASSEMBLY B-12806

Item	Part Number	Description
1	14-7953	Motor - Police Car
2	01-9201	Bracket - Car Motor
3	20-8716-2	Roll Pin, 3-32 x 5/8
4	20-9606-1	Spring Grip Fastener
5	03-8281	Pulley - Car
6	4008-01003-05	Mach. Screw, #8-32 x 5/16
7	C-13094	Motor EMI Filter Assy

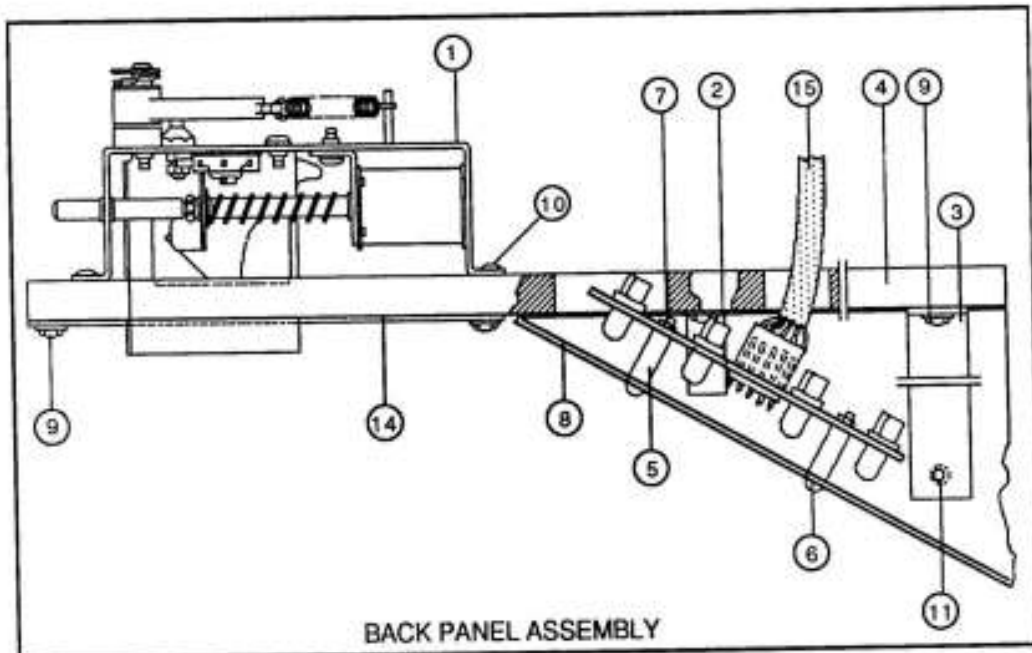

**BACK PANEL ASSEMBLY
D-12822**

Item	Part Number	Description
1	C-12808	Rt. Ramp Diverter Assy
2	01-9279	Small Bracket - Station
3	01-9280	Large Bracket - Station
4	11-831-573	Wood Back Panel
5	03-6047-10	Spacer, 3/4"
6	4006-01005-20	Mach. Screw, 6-32 x 1-1/4
7	4406-01128-00	Nut, 6-32 KEPS
8	31-1006A-573-1	Playfield Plastic
9	4106-01114-08	Sh. Metal Screw, #6 x 1/2
10	4008-01003-08	Mach. Screw, 8-32 x 1/2
11	4008-01003-05	Mach. Screw, 8-32 x 5/16
12	C-12716	4-Lamp Back Panel PCB Assy
13	A-12336-1	Socket & Bulb Assy
14	31-1006-573-11	Playfield Plastic
15	H-12970	Jail House Cable
16	03-7655-4	Harness Clip, 1/4"
17	03-7655-16	Harness Clip, 1"

INNER RAMP ASSEMBLY D-12786

Item	Part Number	Description	Item	Part Number	Description
1	A-12239	Sub-Mini Switch Assy	16	07-6688-16N	Rivet - Nickel Plate, 1/8 x 1/8
2	A-12558	Switch Gate Assembly	17	07-6688-20N	Rivet - Nickel Plate, 1/8 x 1/4
3	A-12783	Switch Gate Assy-Inner	18	31-1006-573-12	Playfield Plastic
4	A-12976	P/Plas Bracket Assy	19	31-1006-573-13	Playfield Plastic
5	B-12156	Single Flash Lamp Assy	20	31-1498-573-D	Decal - Ramp
6	H-12967	Flasher, Switch Cable	21	31-1498-573-E	Decal - Ramp
7	01-8774	Switch Bracket	22	31-1498-573-G	Decal - Ramp
8	01-8795	Ramp Flap	23	4002-01005-06	Mach. Screw, 2-56 x 3/8
9	01-9187	Bracket - Ball Deflect	24	4006-01005-08	Mach. Screw, 6-32 x 1/2
10	03-7520-2	Nylon, Ty - Wrap	25	4006-01005-28	Mach. Screw, 6-32 x 1-3/4
11	03-8022-3	Spacer, 1-11/64 Lg	26	4106-01022-12	Sh. Metal Screw, #6 x 3/4
12	03-8022-4	Spacer, 1/4 Lg	27	4106-01033-08	Sh. Metal Screw, #6 x 1/2
13	03-8022-5	Spacer, 11/32 Lg	28	4406-01128-00	Nut, 6-32 KEPS
14	03-8149-9	Mini Dome - Trans. Red	29	4700-00003-00	Flatwasher, 1/8x9/32x21ga.
15	03-8263	Ramp - Inner	30	4701-00024-00	Lockwasher, #2 Split

OUTER RAMP ASSEMBLY R-12787

Item	Part Number	Description	Item	Part Number	Description
1	A-12782	Switch Gate Assy- Outer	19	07-6688-18N	Rivet, 1/8 x 3/16
2	A-7438-1	Terminal Strip Assembly	20	07-6688-20N	Rivet Nickel Plate, 1/8 x 1/4
3	C-12689	5-Pos Lite Socket Assy	21	31-1006-573-21	Playfield Plastic
4	H-12969	Skill Shot Cable	22	31-1006A-573-2	Playfield Plastic
5	H-12972	Aux Car Cable	23	31-1497-573-A	Decal - Ramp
6	01-8641	Microswitch Mtg. Bracket	24	31-1497-573-B	Decal - Ramp
7	01-8710	Ramp Flap	25	31-1497-573-C	Decal - Ramp
8	01-8947	W/Ramp Holding Bracket	26	31-1498-573-F	Decal - Ramp
9	01-9188	Bracket - Mid Ramp	27	31-1498-573-L	Decal - Ramp
10	01-9189	Bracket - End Ramp	28	4004-01003-10	Mach. Screw, 4-40 x 5/8
11	01-9196	Light Shield Socket	29	4006-01005-08	Mach. Screw, 6-32 x 1/2
12	01-9264	Bracket Car Guide	30	4106-01022-12	Sh. Metal Screw, #6 x 3/4
13	03-7520-2	Nylon, Ty-Wrap	31	4108-01001-20	Sh. Metal Screw, #8 x 1-1/4
14	03-8022-4	Spacer, 1/4" Lg.	32	4406-01128-00	Nut, 6-32 KEPS
15	03-8069-2	Light Shield - Double	33	4700-00003-00	Flatwasher, 1/8x 9/32x21ga.
16	03-8264	Ramp - Outer	34	5070-06258-00	Diode, 1N4001, 1.0 A.
17	03-8285-1	Plastic Grommet	35	5647-12133-04	Microswitch
18	07-6688-16N	Rivet, 1/8 x 1/8			

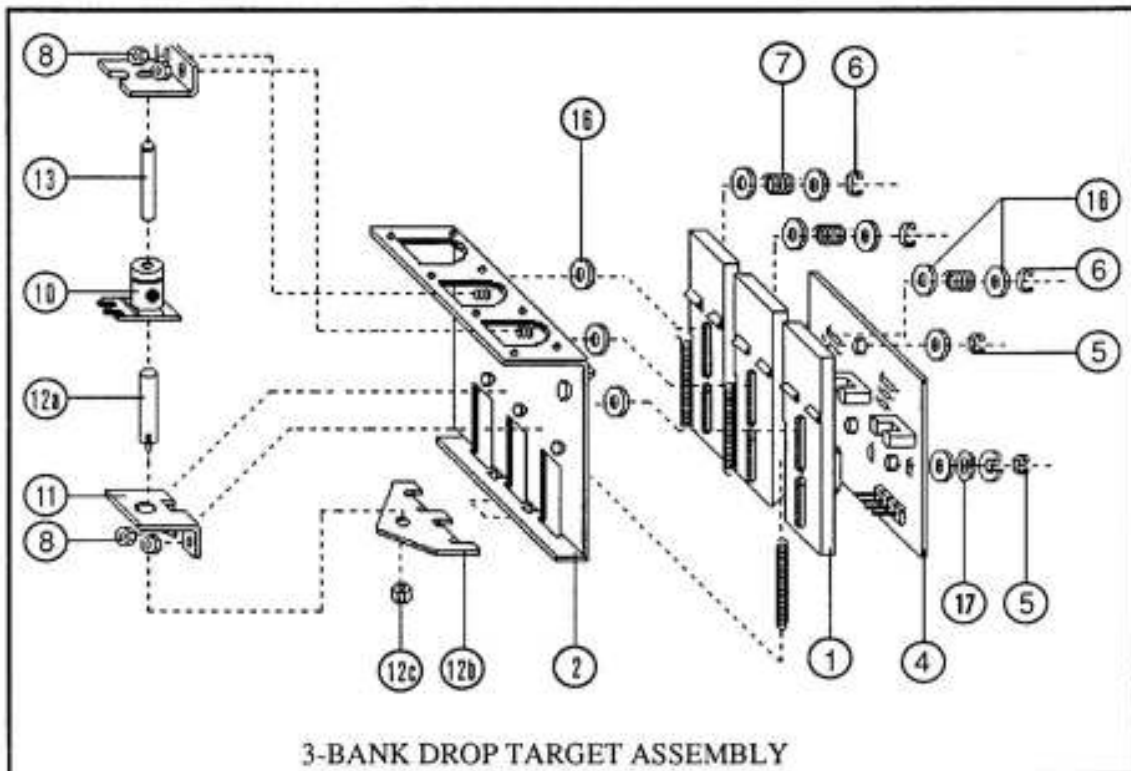

**3-BANK DROP TARGET
C-11223-1**

Item	Part Number	Description
1	03-8036	Plain Target
2	B-11224	3-Bank Tgt Sub-Assy
3	10-364	Target Retractor Spring
4	C-12559	3-Drop Tgt Opto Assembly
5	20-8712-18	"E" Ring, 3/16" Shaft
6	20-8712-25	"E" Ring, 1/4" Shaft
7	10-392	Spring - Compression
8	4408-01119-00	Nut, 8-32 ESN
9	A-11397	Stop Bracket Assembly
10	AE-26-1200	Coil Assembly
11	01-8413	Bracket Coil Mounting
12	A-11389	Plunger & Reset Plate Assy
a)	02-3972-1	Plunger
b)	01-8408	Reset Plate, 3-Bank
c)	4410-01132-00	Nut, 10-32 ESN
13	03-7066-4	Coil Tubing
14	4700-00016-00	Flatwasher, 3/16 x 7/16 x 17 ga.
15	4008-01016-10	Mach. Screw, 8-32 x 5/8 P-RH
16	4700-00072-00	Flatwasher, 17/64 x 1/2 x 21 ga.
17	23-6626	Rubber Grommet

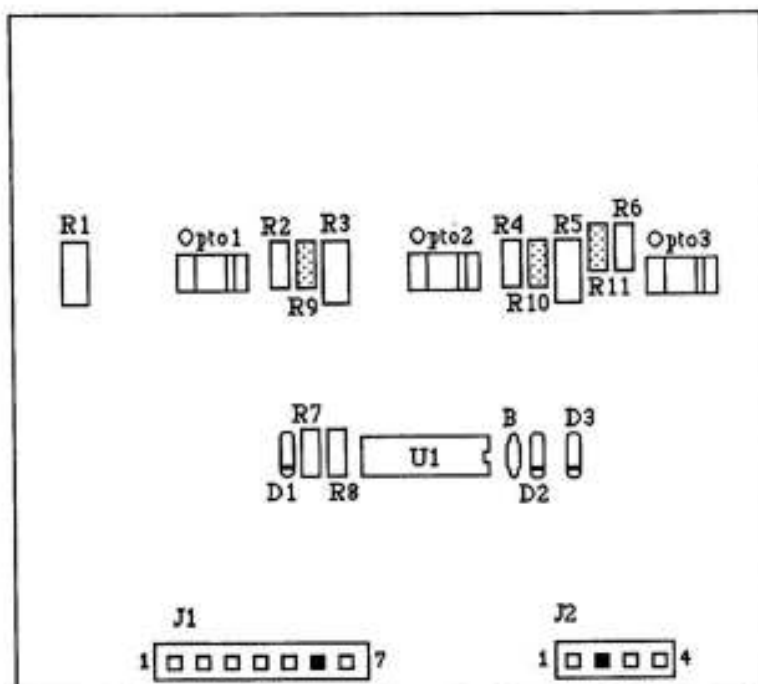

3-BANK DROP TARGET OPTO BOARD C-12559

Part Number	Ckt Designation	Description
5768-12368-00		3-Bank Opto Board
5490-10159-00	Opto 1- Opto3	Opto Interruptor, MDL, S/G
5010-08930-00	R1, R3, R5	Resistor, C.F., 470 Ω , 1/2w, 5%
5010-09162-00	R8	Resistor, C.F., 100K Ω , 1/4w, 5%
5010-09324-00	R2, R4, R6	Resistor, C.F., 27K Ω , 1/4w, 5%
5010-08774-00	R7	Resistor, C.F., 22K Ω , 1/4w, 5%
5043-08980-00	B	Capacitor, .01 μ fd., +80 -20%
5370-12272-00	U1	I.C., Quad. Comp., LM339
5791-10871-04	J2	Connector, 4-pin Hdr, Sq Pin .156
5791-10871-07	J1	Connector, 7-pin Hdr, Sq Pin .156
5070-09054-00	D1 - D3	Diode, 1N4004, 1.0A

STANDUP TARGET ASSEMBLIES (INCLUDING DIODE)

Item	Part Number	Description
1	B-11696-15	Standup Target (Orange)
1	B-11696-6	Standup Target (Yellow)

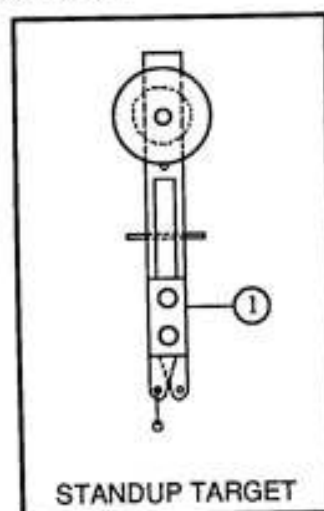





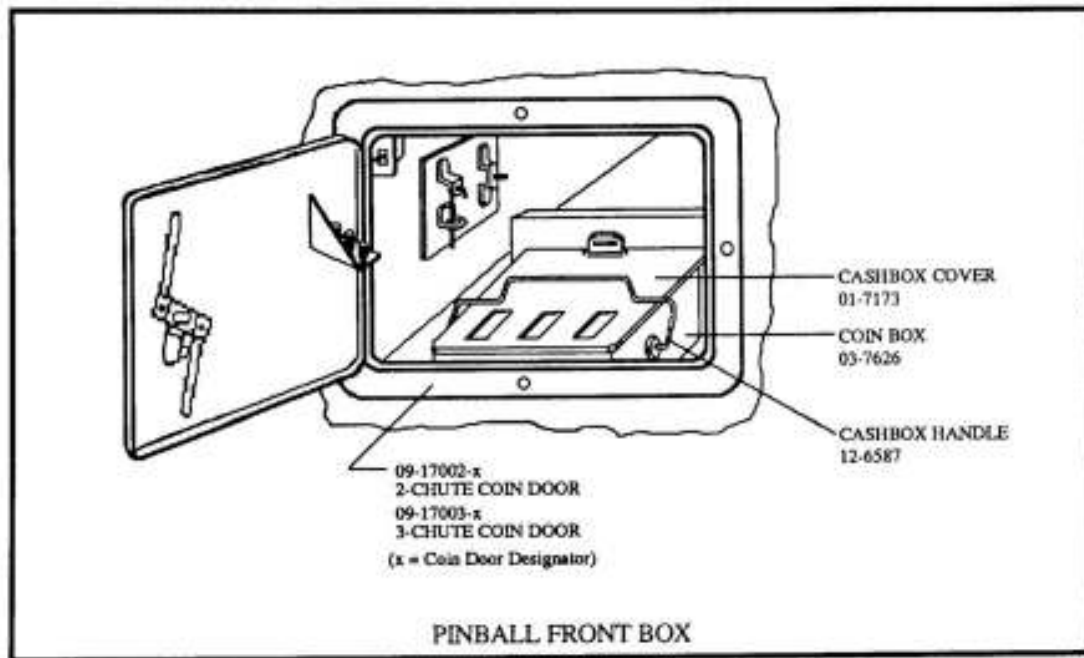
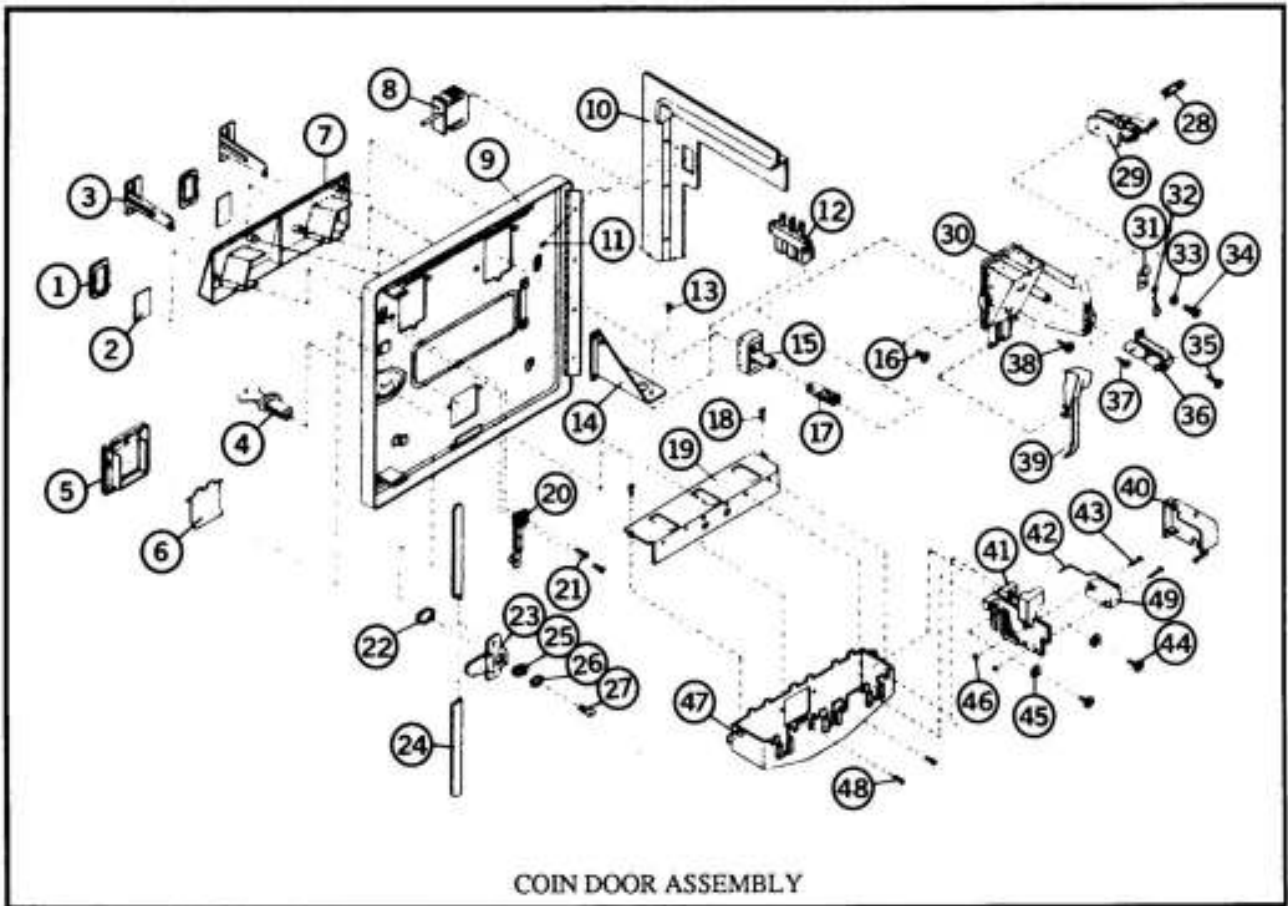

COIN DOOR ASSEMBLY

2-Chute Door - 09-17002-x
 3-Chute Door - 09-17003-x
 ("x" is the country designator)

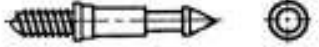
Item	Part Number	Description	Quantity
1	27-1038	Button Cover	2 or 3
2	27-1041-1→49	Price Panel	2 or 3
3	27-1026-1→15	Coin Entry Plate	2 or 3
4	27-1016	Lock Assembly	1
5	27-1061	Coin Return - Bezel	1
6	27-1062	Coin Return Flap	1
7	27-1021	Button Housing - 2-slot	1
	27-1022	Button Housing - 3-slot	1
8	27-1111	Interlock Switch	1
9	27-1006	Coin Door , 2-Slot	1
	27-1007	Coin Door , 3-Slot	1
10	27-1005	Coin Door Frame	1
11	27-1003	M/C Screw, 6-32 x 3/16	4
12	27-1008	Diagnostic Switch	1
13	27-1101	M/C Screw, 4-40 x 1/4	2
14	27-1102	Bracket, Diagnostic Switch	1
15	27-1037	Button	2 or 3
16	27-1078	M/C Screw, 6-32 x 3/8	2 or 3
17	27-1039	Conical Spring	2 or 3
18	27-1079	Self-tapping Screw, #6 x 1/4	2
19	27-1077	Coinbox Cover	1
20	27-1066	Slam Switch	1
21	27-1067	M/C Screw, 4-40 x 1/2	2
22	27-1017	Nut (key)	1
23	27-1012	Locking Cam	1
24	27-1011	Locking Arm	2
25	27-1020	Washer	1
26	27-1018	Star Washer	1
27	27-1019	M/C Screw	1
28	27-1089	R-Ring	1
29	27-1083	Retainer	1
30	27-1081	Coin Inlet Chute	2 or 3
31	27-1088	Wire Clamp	2 or 3
32	27-1025	Key Hook	2 or 3
33	27-1086	Washer, #6	2 or 3
34	27-1078	M/C Screw, 6-32 x 3/8	2 or 3
	27-1078	M/C Screw, 6-32 x 7/8	2 or 3
35	27-1079	Self-tapping Screw, #6 x 1/4	2 or 3
36	27-1084	Lamp Socket	2 or 3
	27-1085	Lamp	2 or 3
37	27-1096	Self-tapping Screw, #5 x 3/8	2 or 3
38	27-1087	M/C Screw, 6-32 x 5/8	2 or 3
39	27-1082	Lever Arm	2 or 3
40	27-1097	Switch Cover	2 or 3
41	27-1091	Coin Accept Chute	2 or 3
42	27-1075	Wire Form	2 or 3
	27-1093	Wire Form	2 or 3
43	27-1094	M/C Screw, 6-40 x 7/8	2
44	27-1087	M/C Screw, 6-32 x 5/8	2
45	27-1086	Washer, #6	2
46	27-1095	Nut, 4-40	2
47	27-1076	Coin Return Box	1
48	27-1078	M/C Screw, 6-32 x 3/8	2
49	27-1092	Microswitch	2 or 3

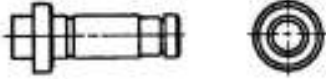
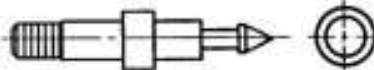
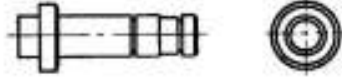
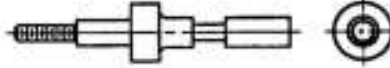
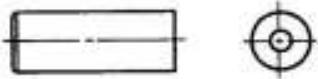
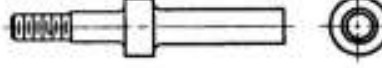

POSTS

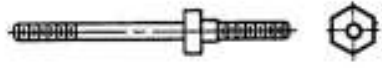
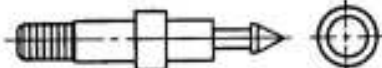
 <p>02-3905</p>	 <p>02-4271-1</p>
 <p>02-4002-1</p>	 <p>02-4271-2</p>
 <p>02-4003</p>	 <p>02-4271-3</p>
 <p>02-4008</p>	 <p>02-4014</p>
 <p>02-4036</p>	 <p>02-4020</p>
 <p>02-4056</p>	 <p>02-4269</p>
 <p>02-4254</p>	 <p>02-4002-3</p>

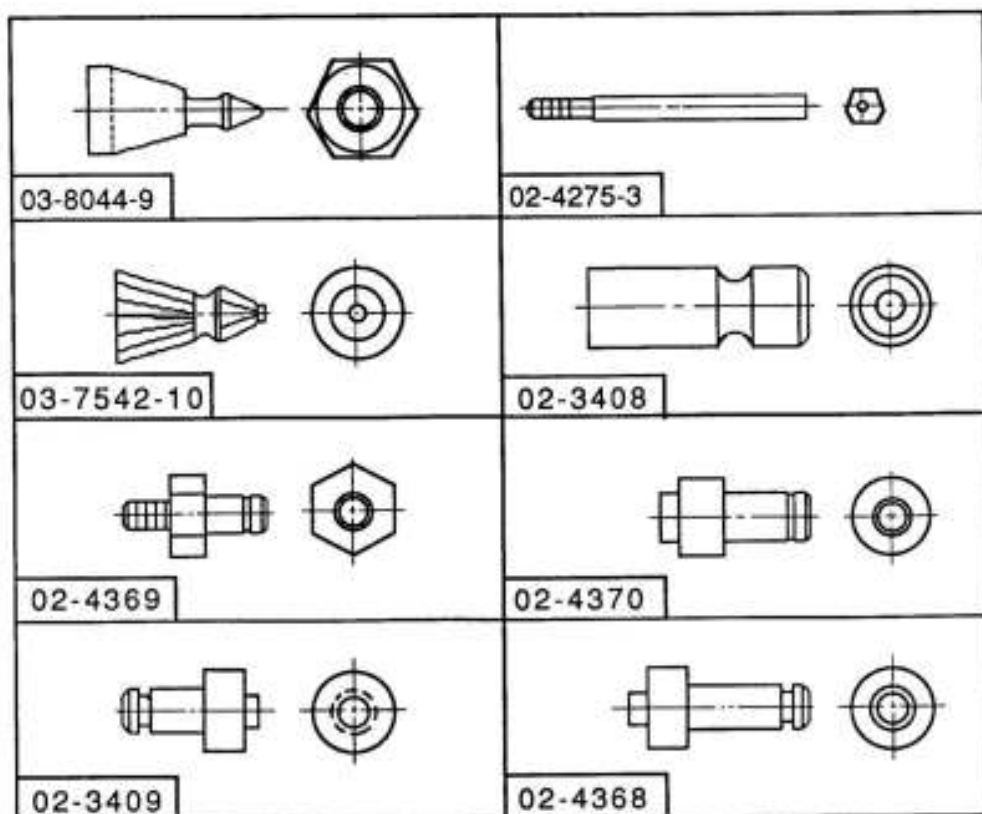

POSTS

Part No.	Description	Qty.	Part No.	Description	Qty.
02-3408	Playfield Post	1	02-4254	Support Post, 8-32	1
02-3409	Spring Post	4	02-4269	RMP Post, 3-7/16	1
02-3905	Bumper Post, #8 W.S.	7	02-4271-1	Post	4
02-4002-1	Post Fastening Screw	10	02-4271-2	Post	6
02-4002-3	Post Fastening Screw	2	02-4271-3	Post	2
02-4003	Bumper Post, 8-32 M.S.	6	02-4275-3	Mounting Post, 3-1/16	1
02-4008	Bumper Post - Rubber	9	02-4368	Post - Pivot	1
02-4014	Support Post	3	02-4369	Drive Post	1
02-4020	Support Post	4	02-4370	Post - Idler Pulley	1
02-4036	Bumper Post - Rubber	6	03-7542-10	Bumper Post - Trans. Blue	34
02-4056	Bumper Post	1	03-8044-9	Mini Post - Trans. Red	3

RUBBER PARTS

Part No.	Description	Qty.	Part No.	Description	Qty.
23-6300	Rubber Ring, 5/16"	7	23-6309	Rubber Ring, 4"	1
23-6301	Rubber Ring, 3/4"	3	23-6313-1	Rubber Grommet	1
23-6302	Rubber Ring, 1"	3	23-6327	Ball Shooter Tip	1
23-6303	Rubber Ring, 1-1/4"	4	23-6420	Rubber Grommet	1
23-6304	Rubber Ring, 1-1/2"	2	23-6519-4	Rubber Ring, Red	2
23-6305	Rubber Ring, 2"	1	23-6535	Rubber Grommet	4
23-6306	Rubber Ring, 2-1/2"	2	23-6552	Rubber Bumper Slvg - Yel	5
23-6307	Rubber Ring, 3"	1	23-6626	Rubber Grommet	6
23-6308	Rubber Ring, 3-1/2"	1			

BACKBOX PARTS LIST

Item	Part Number	Description
1	01-6645	Venting Screen
2	B-10686-1*	Knocker & Bracket Assy
3	A-12497	Upr Insert Bd Hinge Assy
4	D-12184-1	PCB Plate Assembly
5	A-12498	Lwr Insert Bd Hinge Assy
6	D-11883-573*	System 11B CPU Board
7	5100-09418-00	Bridge Rectifier, 100v, 35A.
8	5040-09051-00	Capacitor, 30,000 μ Fd, 25v
9	A-11-914	POLICE FORCE , Backbox
10	D-12247-566*	Aux. Pwr Driver Board
11	01-9047	Insert Stop Bracket
12	D-12246*	Power Supply Assembly
13	20-9549	Cam Lock, 3/4"D x 27/32"L
14	D-11581-573*	Audio Board Assembly
15	D-12313-573*	Backbox Interconnect Board
16	C-12597	Speaker Hood Assy
a)	31-1422-573	Speaker Grill (Screened)
b)	03-8261	Speaker Hood
c)	5555-12068-00	Speaker 4" Piezo, 50w
17	B-13035-L	Lite Hood Assy - Left
18	B-13035-R	Lite Hood Assy - Right
	01-9011-L**	Left Backbox Hinge
	01-9011-R**	Right Backbox Hinge

* Refer to Individual Unit's Parts List

** Not Shown

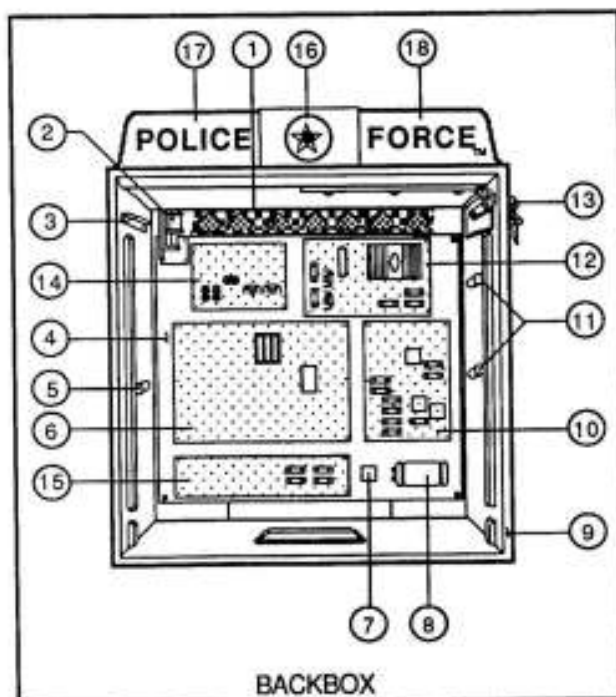

MISCELLANEOUS *POLICE FORCE* PARTS

Part Number	Description	Part Number	Description
A-8552-573	Backglass Assembly	573-IN	POLICE FORCE , Insert
31-1357-573	POLICE FORCE , Backglass	01-6571	Hinge Mtg Bracket, Insert Board
03-7960-573	Playfield Mylar	01-6655	Latch-Insert Board
08-7028-T	Glass-Playfield	01-6652	Stop Bracket
31-1006-573	Playfield Plastics	31-1510-573	Decal - Spin Target
31-1002-573	Playfield (Screened)	31-1006A-573	Playfield Plastic (Screened)
31-1463-573	Drop Target Decal Set	31-1008-573	Bottom Arch (Screened)
31-1497-573	Decal Sheet, Ramps	31-1009-573	Shooter Plate (Screened)
31-1498-573	Decal Sheet, Ramps	31-1504-573	Decal - Police Domestic
31-1422-573	Speaker Grille (Screened)	5795-10937-09	Ribbon Cable, 20-Conductor, 9"
08-7456-2	Backbox Glass, 27 x 26-1/2 x 1/8	5795-10938-27	Ribbon Cable, 26-Conductor, 27"
		5795-10703-24	Ribbon Cable, 20-Conductor, 24"

Solenoids/Flashers

Item	Part No.	Description
1A	AE-23-800	Outhole Kicker
1C	#906/89 Flashlamps	Shark Flashers
2A	AE-23-800	Top Left Eject
2C	#906/89 Flashlamps	Croc Flashers
3A	AE-26-1200	Ball Diverter
3C	#906/89 Flashlamps	Rat Flashers
4A	AE-26-1200	Rt 3-Bank Drop Target Reset
4C	#906/89 Flashlamps	Weasel Flashers
5A	AE-23-800	Lower Right Eject
5C	#906/89 Flashlamps	Jackpot/Scope Flashers
6A	AE-26-1200	Mdl 3-Bank Drop Target Reset
6C	#906 Flashlamp	Million Flasher
7A	AE-23-800	Knocker
7C	#906 Flashlamps	Left Dome Flashers
8A	AE-23-800	Top Right Eject
8C	#906 Flashlamps	Right Dome Flashers
9	#89 Flashlamps	Take Highest Flashers
10	5580-09555-01	Playfield Gen Illumin Relay *
11	5580-09555-01	Backbox Gen Illumin Relay *
12	5580-09555-01	Solenoid A/C Select Relay**
13	#906 Flashlamp	Skill (Firing Range) Flasher
14	#906 Flashlamps	Top Cop Flashers
15	14-7953	Car On - Off Motor
16	5580-09555-01	Car Up - Down Relay *
17	AE-23-800	Left Jet Bumper
18	AE-26-1500	Left Kicker ("Sling")
19	AE-23-800	Right Jet Bumper
20	AE-26-1500	Right Kicker ("Sling")
21	AE-23-800	Lower Jet Bumper
22	AE-23-800	Ball Shooter Lane Feeder
-	FL 11630/50VDC	Lower Left and Right Flipper

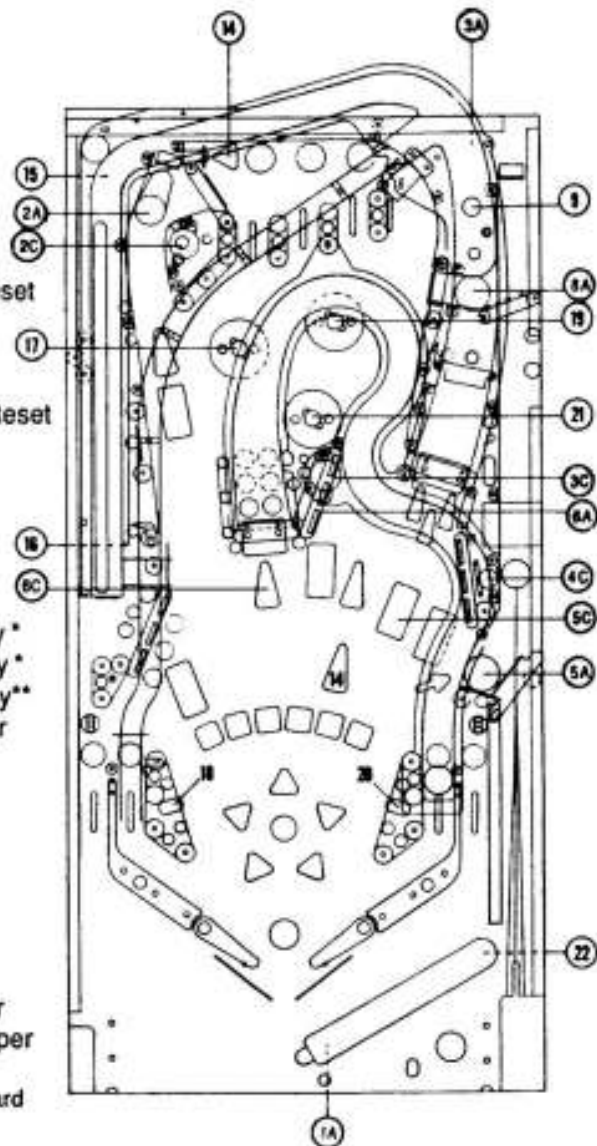

* - On Relay Board, C-11998-1, on Playfield and Insert Board

** - In backbox on Aux Power Driver Bd, D-12247

Switches

Item	Part No.	Description
1	(See Figure 2)	Plumb Bob Tilt
2	5580-09555-01	C Side Power/A-C Relay
3	SW-1A-126	Credit Button
4	27-1092	R Coin Chute (USA)
5	Not Used (USA)	Center Coin Chute
6	27-1092	L Coin Chute (USA)
7	27-1066	Slam Tilt
8	27-1008	High Score Reset*
9	B-8306-1	Playfield Tilt
10	5647-12133-12	Outhole
11	5647-12073-08	Ball Trough 1 (right)
12	5647-09957-00	Ball Trough 2 (left)
13	Not Used	
14	5647-12073-04	Ball Shooter Lane
15	5647-12133-11	Top Right Eject
16	Not Used	
17	B-11696-15	Left Standup Target (top)
18	B-11696-15	Left Standup Target (mdl)
19	B-11696-15	Left Standup Target (lwr)
20	p/o C-12559	Rt 3-Bank Dr Tgt (top)
21	p/o C-12559	Rt 3-Bank Dr Tgt (mdl)
22	p/o C-12559	Rt 3-Bank Dr Tgt (lwr)
23	5647-12133-11	Bottom Right Eject
24	5647-12133-11	Top Left Eject
25	p/o C-12559	Mdl 3-Bank Dr Tgt (top)
26	p/o C-12559	Mdl 3-Bank Dr Tgt (mdl)
27	p/o C-12559	Mdl 3-Bank Dr Tgt (lwr)
28	Not Used	
29	Not Used	
30	Not Used	
31	5647-12133-12	Car Up
32	5647-12133-12	Car Down
33	Not Used	
34	5647-12133-08	Enter Right Ramp
35	B-11696-6	Top Left Target (TOP COP)
36	5647-12073-06	Diverter In
37	5647-12133-04	Right Ramp to Car
38	5647-12073-21	Right Ramp to Wire
39	Not Used	
40	Not Used	
41	p/o C-12946	Skill Switch (spinner)
42	Not Used	
43	Not Used	
44	Not Used	
45	5647-12133-08	Enter Mdl Ramp
46	5647-12073-11	Middle Ramp Score
47	Not Used	
48	Not Used	
49	5647-12073-19	Right Outlane (drain)
50	5647-12073-19	Left Outlane (drain)
51	5647-12073-19	Left Return Lane
52	5647-12073-19	Right Return Lane
53	Not Used	

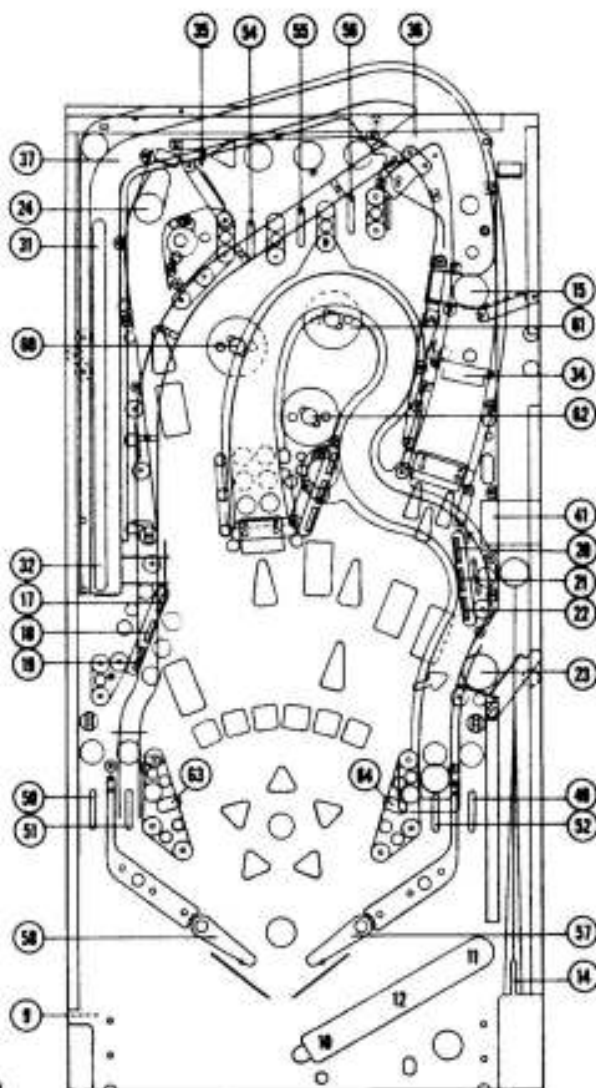

Item	Part No.	Description
54	5647-12073-19	G (in G-U-N)
55	5647-12073-19	U (in G-U-N)
56	5647-12073-19	N (in G-U-N)
57	-	R Flipper Lane Change**
58	-	L Flipper Lane Change**
59	Not Used	
60	B-12030-2	Left Jet Bumper
61	B-12030-2	Right Jet Bumper
62	B-12030-2	Lower Jet Bumper
63	-	BL Kicker***
64	-	BR Kicker***
-	SW-10A-48	Flipper Button (Cabinet sides)

Notes: * Part Number is for entire Diagnostic Switch Assembly, including H S Reset Switch;

** Optotransistor on Backbox Interconnect Bd; *** [Paired Kicker Actuating Sw: A-4834-H; B-8734-1]

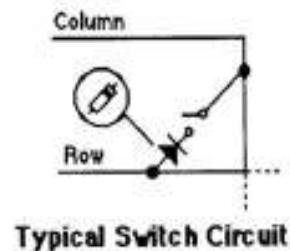
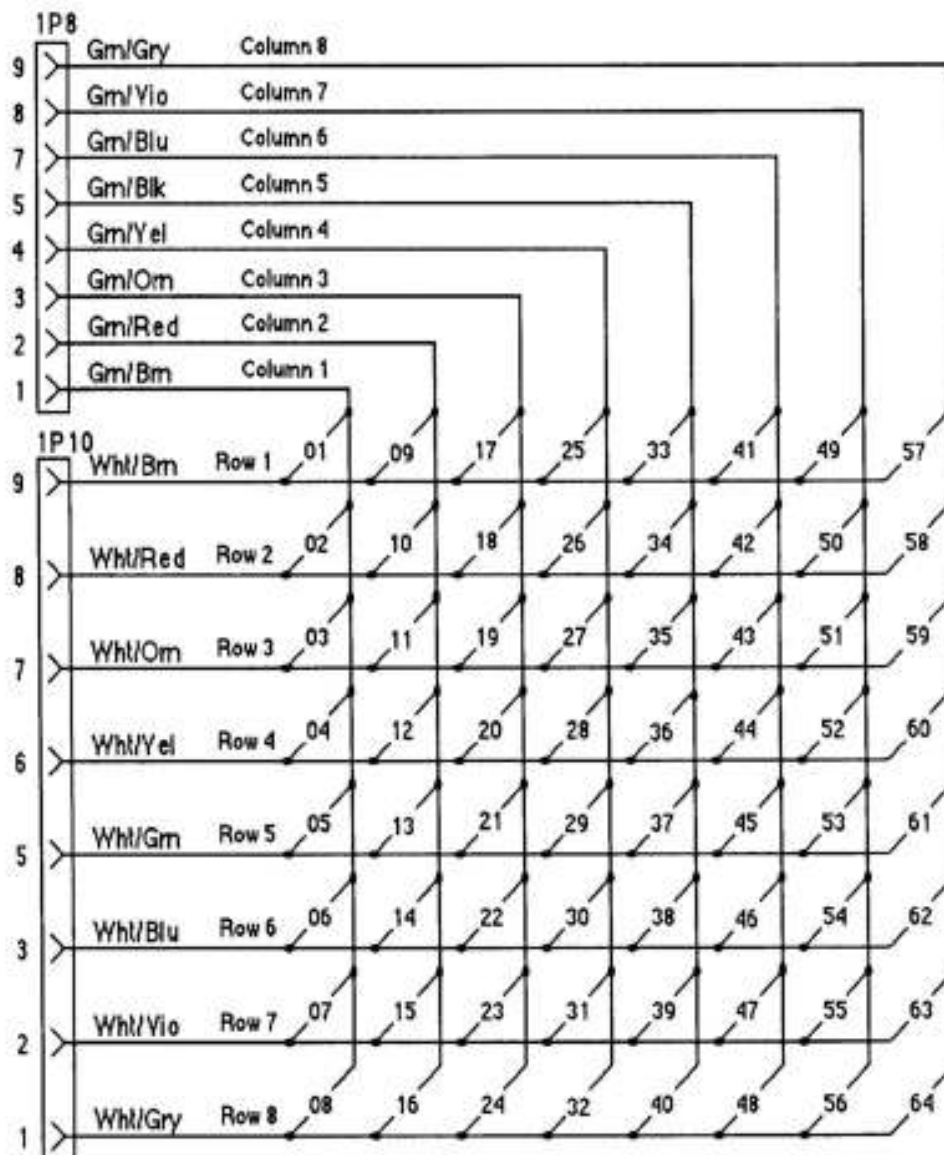

POLICE FORCE Switch-Matrix Table

COLUMN \ ROW	1 Q45 GRN-BRN 1J8-1	2 Q49 GRN-RED 1J8-2	3 Q44 GRN-ORN 1J8-3	4 Q46 GRN-YEL 1J8-4	5 Q43 GRN-BLK 1J8-5	6 Q47 GRN-BLU 1J8-7	7 Q42 GRN-VIO 1J8-8	8 Q48 GRN-GRY 1J8-9
1	WHT-BRN 1J10-9 Plumb Bob Tilt 1	Playfield Tilt 9	L 3-Bank Stndup Tgt (upr) 17	Mid 3-Bank Dr Target (upr) 25	33	SKL/Switch (Spinner) 41	Right Outlane 49	Flipper Right 57
2	WHT-RED 1J10-8 C Side Power A/C Relay 2	Outhole 10	L 3-Bank Stndup Tgt (mid) 18	Mid 3-Bank Dr Target (mid) 26	Enter Right Ramp 34	42	Left Outlane 50	Flipper Left 58
3	WHT-ORN 1J10-7 Credit Button 3	Ball Trough #1 (R) 11	L 3-Bank Stndup Tgt (lwr) 19	Mid 3-Bank Dr Target (lwr) 27	Top Left Tgt (Top Cop) 35	43	Left Return Lane 51	59
4	WHT-YEL 1J10-6 Right Coin Chute 4	Ball Trough #2 (L) 12	R 3-Bank Dr Target (upr) 20	28	Diverter In 36	44	Right Return Lane 52	Left Jet Bumper 60
5	WHT-GRN 1J10-5 Center Coin Chute 5	13	R 3-Bank Dr Target (mid) 21	29	R Ramp to Car 37	Enter Mid Ramp 45	53	Right Jet Bumper 61
6	WHT-BLU 1J10-3 Left Coin Chute 6	Ball Shooter 14	R 3-Bank Dr Target (lwr) 22	30	R Ramp to Wire 38	Mid Ramp Score 46	G 54	Lwr Jet Bumper 62
7	WHT-VIO 1J10-2 Slam Tilt 7	Top Right Eject 15	BR Eject 23	Car Up 31	39	47	U 55	BL Kicker ("sling") 63
8	WHT-GRY 1J10-1 High Score Reset 8	16	Top Left Eject 24	Car Down 32	40	48	N 56	BR Kicker ("sling") 64

BL = Bottom Left BR = Bottom Right

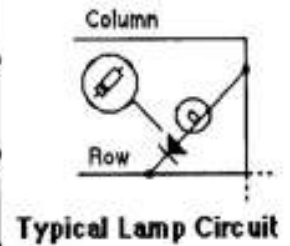
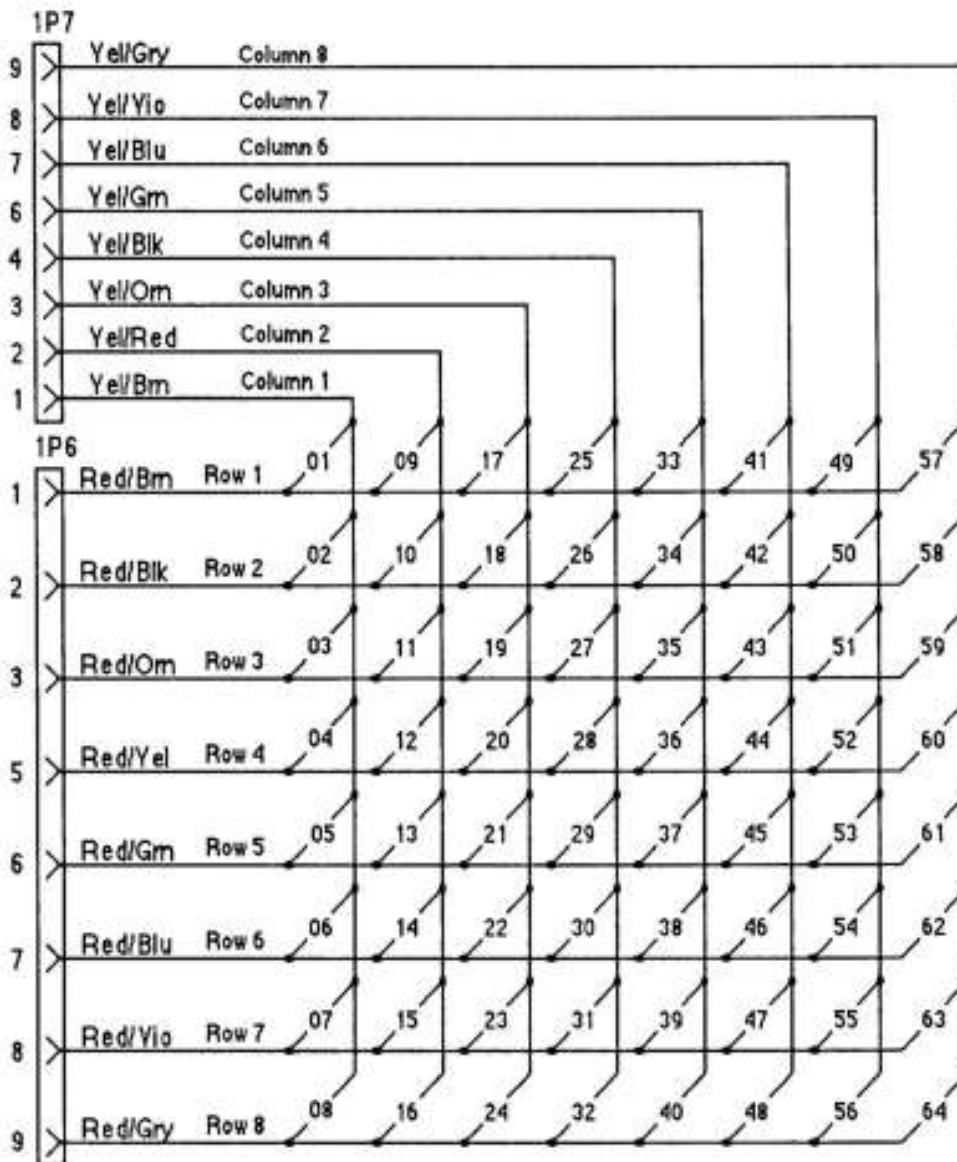

POLICE FORCE Lamp-Matrix Table

COLUMN	1 O66 YEL-BRN 1J7-1	2 O64 YEL-RED 1J7-2	3 O62 YEL-ORN 1J7-3	4 O60 YEL-BLK 1J7-4	5 O58 YEL-GRN 1J7-6	6 O56 YEL-BLU 1J7-7	7 O54 YEL-VIO 1J7-8	8 O52 YEL-GRY 1J7-9
O80 RED-BRN 1J6-1	Hot Sheet Hot Score 1	2X	P	10k (Mdl Ramp) 25	Shark	Jackpot WL 41	Right Outlane 49	L 3-Bank Stndup Tgt (upr) 57
O81 RED-BLK 1J6-2	Hot Sheet Extra Ball 2	3X	O	20k (Mdl Ramp) 28	Croc	Skill 10K (Firing Range) 42	Left Outlane 50	L 3-Bank Stndup Tgt (mdl) 58
O82 RED-ORN 1J6-3	Hot Sheet 5 Free Games 3	4X	L	50k (Mdl Ramp) 27	Drug Rat	Skill 25K (Firing Range) 43	Left Return 51	L 3-Bank Stndup Tgt (lwr) 59
O83 RED-YE 1J6-5	Hot Sheet Multi-Ball 4	5X	I	75k (Mdl Ramp) 28	Weasel	Skill 50K (Firing Range) 44	Right Return 52	Scope (Backglass) 60
O84 RED-GRN 1J6-6	Hot Sheet Spot P-O-L-I-C-E 5	6X	C	100k (Mdl Ramp) 29	Shark In Jail 37	Skill 75K (Firing Range) 45	Take Highest 53	L Jackpot (Backglass) 61
O85 RED-BLU 1J6-7	Spot Police 6	Special WL 14	E	150k (Mdl Ramp) 30	Croc In Jail 38	Skill 100K (Firing Range) 46	G	R Jackpot (Backglass) 62
O86 RED-VIO 1J6-8	Lock 1 7	Hot Sheet Bonus WL 15	Top Extra Ball 23	Unlimited Million WL 31	Drug Rat In Jail 39	Car Headlight 47	U	L Dome (Backglass) 63
O87 RED-GRY 1J6-9	Lock 2 8	Adv. Handcuff Bonus 16	Shoot Again 24	Top Cop Bonus 32	Weasel In Jail 40	Car Headlight 48	N	R Dome (Backglass) 64

Lamps

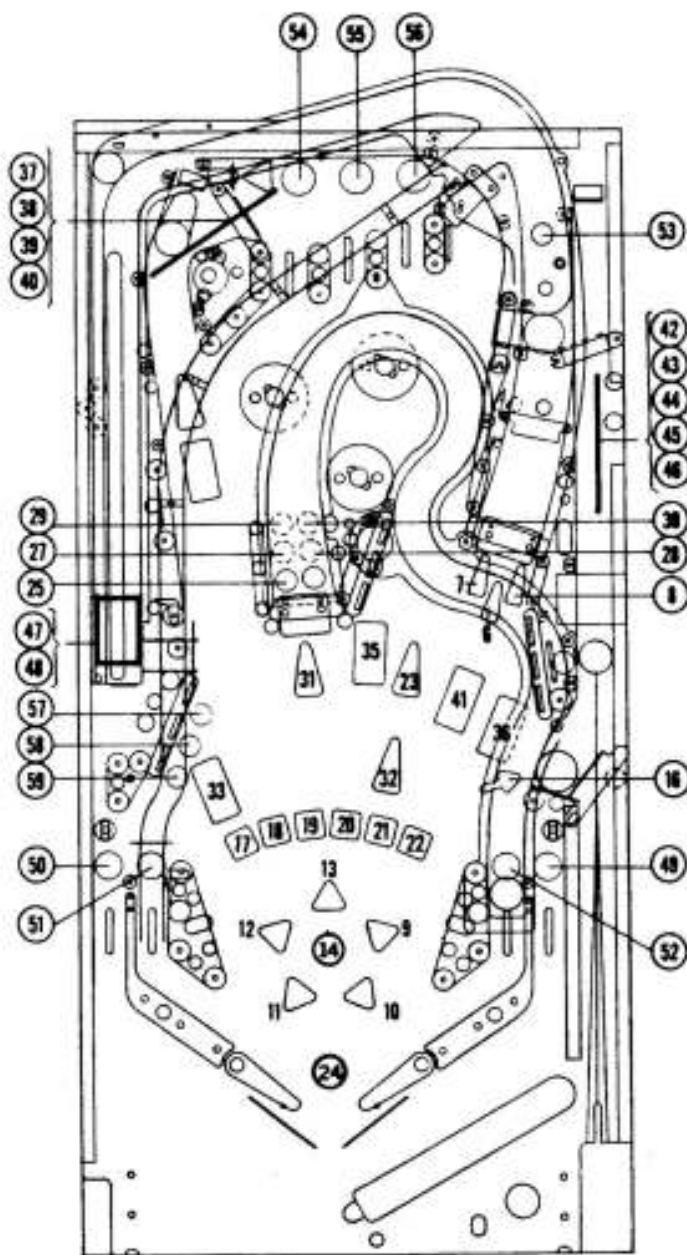

Lamp Location/Description

- 1 HOT SCORE (Hot Sheet -B'box)
- 2 EXTRA BALL (Hot Sheet -B'box)
- 3 5 Free Games (Hot Sheet -B'box)
- 4 Multi-ball (Hot Sheet -B'box)
- 5 Spot P-O-L-I-C-E (Hot Sheet -B'box)
- 6 SPOT POLICE W/L
- 7 LOCK 1
- 8 LOCK 2
- 9 2X
- 10 3X
- 11 4X
- 12 5X
- 13 6X
- 14 SPECIAL
- 15 HOT SHEET
- 16 ADV. HANDCUFF BONUS
- 17 P (in POLICE)
- 18 O (in POLICE)
- 19 L (in POLICE)
- 20 I (in POLICE)
- 21 C (in POLICE)
- 22 E (in POLICE)
- 23 Top EXTRA BALL
- 24 SHOOT AGAIN
- 25 10K (Mdl Ramp)
- 26 20K (Mdl Ramp)
- 27 50K (Mdl Ramp)
- 28 75K (Mdl Ramp)
- 29 100K (Mdl Ramp)
- 30 150K (Mdl Ramp)
- 31 UNLIMITED MILLION W/L
- 32 TOP COP
- 33 Shark
- 34 Croc
- 35 Drug Rat
- 36 Weasel
- 37 Loan Shark (in Jail)
- 38 Machine Gun Croc (in Jail)
- 39 Drug Rat (in Jail)
- 40 Diamond Weasel (in Jail)
- 41 JACKPOT
- 42 Skill 10K (Firing Range)
- 43 Skill 25K (Firing Range)
- 44 Skill 50K (Firing Range)
- 45 Skill 75K (Firing Range)
- 46 Skill 100K (Firing Range)
- 47 Car Headlight
- 48 Car Headlight
- 49 R Outlane
- 50 L Outlane
- 51 L Return Lane
- 52 R Return Lane
- 53 Take Highest
- 54 G (in GUN)

Lamp Location/Description

- 55 U (in GUN)
- 56 N (in GUN)
- 57 L 3-bank Standup Target (top)
- 58 L 3-bank Standup Target (mdl)
- 59 L 3-bank Standup Target (lwr)
- 60 Scope
- 61 Left Jackpot
- 62 Right Jackpot
- 63 Left Dome
- 64 Right Dome

Playfield Parts

Item	Part No.	Description
1	12-6842	Bottom Arch Fence
2	12-6468	Anti-rebound Wire
3	C-11626-L-3	Lwr Left Flipper Assy
a)	20-9250-6	Lg Flipper Paddle & Shaft
4	B-12363-L	Left Flipper Return Frame
5	B-12665	Kicker Arm ("Sling") Assy
a)	B-11203-R-1	Coil & Bracket Assy
6	B-12807	Wire Ramp & Switch Assy
a)	12-6837	Wire Ramp
7	B-11696-15	Orange Standup Target (3)
8	B-12805	Police Car
9	12-6466-6	Wireform, 1-1/2"
10	A-12783	Cntr Ramp Ball Gate (Entr)
a)	12-6847	Gate Wire
b)	12-6870	Switch Actuating Wire
11	B-9414-1	Jet Bumper Assy (3)
a)	B-9415-1	Brmpr Coil/Bracket Assy
12	B-12824	Ball Guide Assembly
13	B-12823	Ball Guide Assembly
14	B-9361-R-6	Top Left Eject Hole
a)	B-9362-R-1	Coil & Bracket Assembly
b)	03-7351-1-9	Tr Red Plastic Ball Seat
15	A-12121	Ball Stop Barcket Assy
16	C-12827	Ball Guide Assembly
17	B-11696-6	Yellow Standup Target
18	A-12160	Ball Gate Assembly
a)	12-6690	Gate Wire
19	R-12787	Right Ramp Assembly
20	C-12808	Divorter, Right Ramp
21	A-8244-R	1-Way Ball Gate Assembly
22	B-12826	Ball Guide Assembly
23	12-6466-5	Wireform, 1-1/4"
24	B-12267	TR Eject (Entr/Exit)Ball Gate
a)	12-6802	Gate Wire
25	B-9361-R-1	Top Right Eject Hole
a)	B-9362-L-1	Coil & Bracket Assembly
b)	03-7351-1-9	Tr Red Plastic Ball Seat
26	B-12825	Ball Guide Assembly
27	A-12782	Ball Gate Assembly
a)	12-6824	Gate Wire
b)	12-6870	Switch Actuating Wire
28	A-12558	Ball Gate Assembly
a)	12-6796	Gate Wire
29	B-12785	Spinning Target Assembly
30	C-11223-1	Mdl & Rt 3-Bank Drop Target
a)	C-12559	Opto Switch PC Board
31	A-11760	Lower Shooter Lane Ball Gate
a)	12-6750	Gate Wire
32	B-9361-R-8	Bottom Right Eject Hole
a)	B-9362-R-1	Coil & Bracket Assembly
b)	03-7351-1-9	Tr Red Plastic Ball Seat
33	12-6466-7	Wireform, 1-3/4"
34	D-12786	Center Ramp Assembly
35	B-12665	Kicker Arm ("Sling") Assy
a)	B-11203-L-1	Coil & Bracket Assy

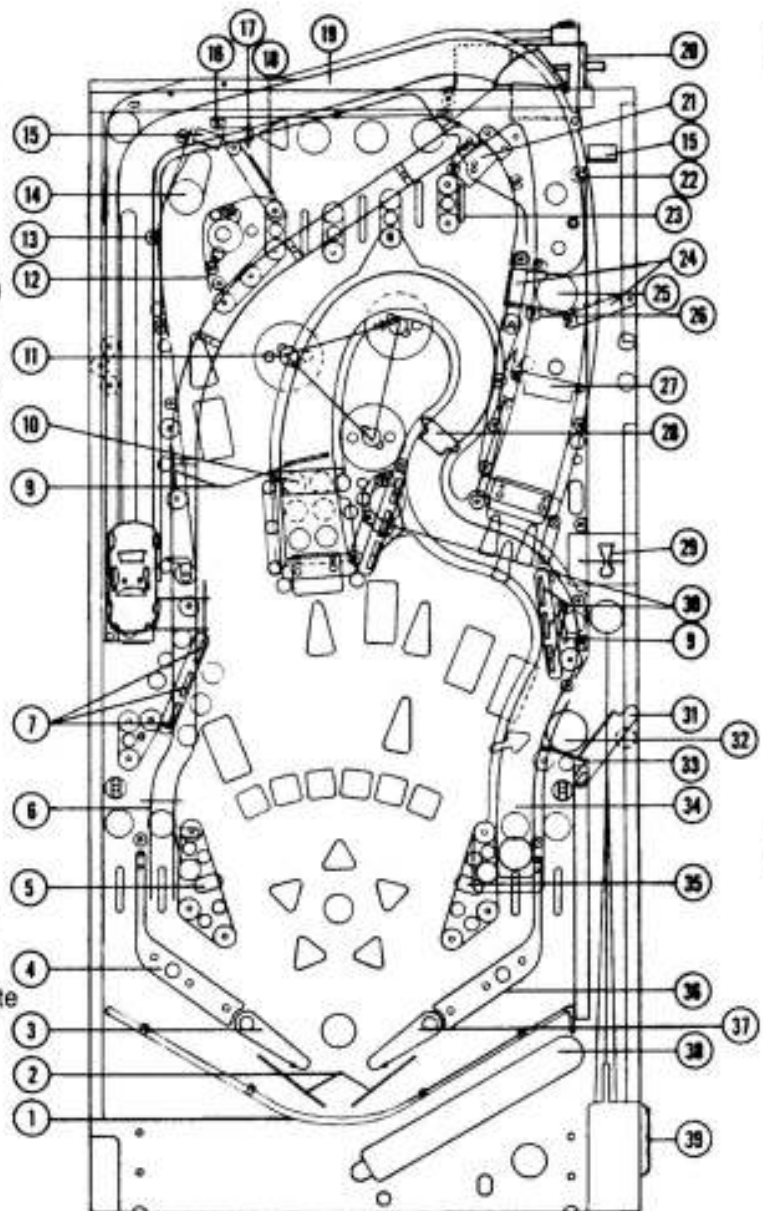

Item	Part No.	Description
36	B-12363-R	Right Flipper Return Frame
37	C-11626-R-3	Lwr Right Flipper Assy
a)	20-9250-6	Flipper Arm on Shaft
38	C-9638	Ball Shooter Lane Feeder
a)	B-9362-R-1	Coil & Bracket Assembly
39	Parts below are located beneath Bottom Arch:	
a)	B-8623	Upr Trough Baffle Assy
b)	C-8235	Lwr Trough Baffle Assy
c)	12-6542	Baffle Wire form
d)	01-3569-1	Ball Trough
e)	01-5575	Bottom Arch Mtg Bracket
f)	B-8039-2	Outhole Kicker Assy

UNIQUE POLICE FORCE PARTS LIST

For your information, the parts listed below are parts that are unique to the **POLICE FORCE** game. This data is provided as part of our ongoing program of providing as much information as we can about the products of Williams Electronics Games.

(NOTE: In some instances, the parts are not available as individual items, because they are integral parts of assemblies, or they are raw materials from which other parts are fabricated during the manufacturing process.)

Part No.	Description	Part No.	Description
A-12782	Switch Gate Assy - Outer	D-12768-573	Bottom Arch Assy
A-12783	Switch Gate Assy - Inner	D-12786	Inner Ramp Assy
A-12961-L	Micro Sw Assy - Car	D-12822	Back Panel Assy
A-12961-R	Micro Sw Assy - Car		
B-12785	Tgt Opto Switch Assy	R-12787	Outer Ramp Assy
B-12800	Traverse Bracket Assy	RM- 27-02	Cable Cover, P Car
B-12803	Idler Pulley Assy		
B-12805	Police Car Assy	01-9283	Light Mounting Bracket
B-12806	Car Motor Bracket		
B-12807	Ball C/Wire Assy	02-4252-29	F-F Spacer, 1-13/16"
B-12823	Ball Guide Assy	02-4252-30	F-F Spacer, 1-7/8"
B-12824	Ball Guide Assy		
B-12825	Ball Guide Assy	11-573-PL	Wood Playfield
B-12826	Ball Guide Assy	11-831-573	Wood Back Panel
B-12977	Playfield Plastic Assy	11-899-573	Cabinet - POLICE FORCE
B-12978	Playfield Plastic Assy	11-912-A	Wood Rail, 37-7/8
B-9361-R-8	Ball Eject Assy	11-912-B	Wood Rail, 37-7/8
		11-912-D	Wood Rail, 20-1/4
C-12827	Ball Guide Assembly	11-915	Wood Speaker Box

Notes

Section 3
*Reference
Diagrams
&
Schematics*

- **Diagrams and Schematics:**

- **Cabinet Wiring**
- **3-Bank Opto Board**
- **Power Supply Board**
- **System 11B CPU Board**
- **Master Display Board**
- **Audio Board**
- **Aux Power Driver Board**
- **Backbox Interconnect Board**
- **Controlled, Special, & Switched Solenoids**
- **Power Wiring**
- **Game Circuit Boards Interboards Signals**

- **Diagnostic Test Flowchart**

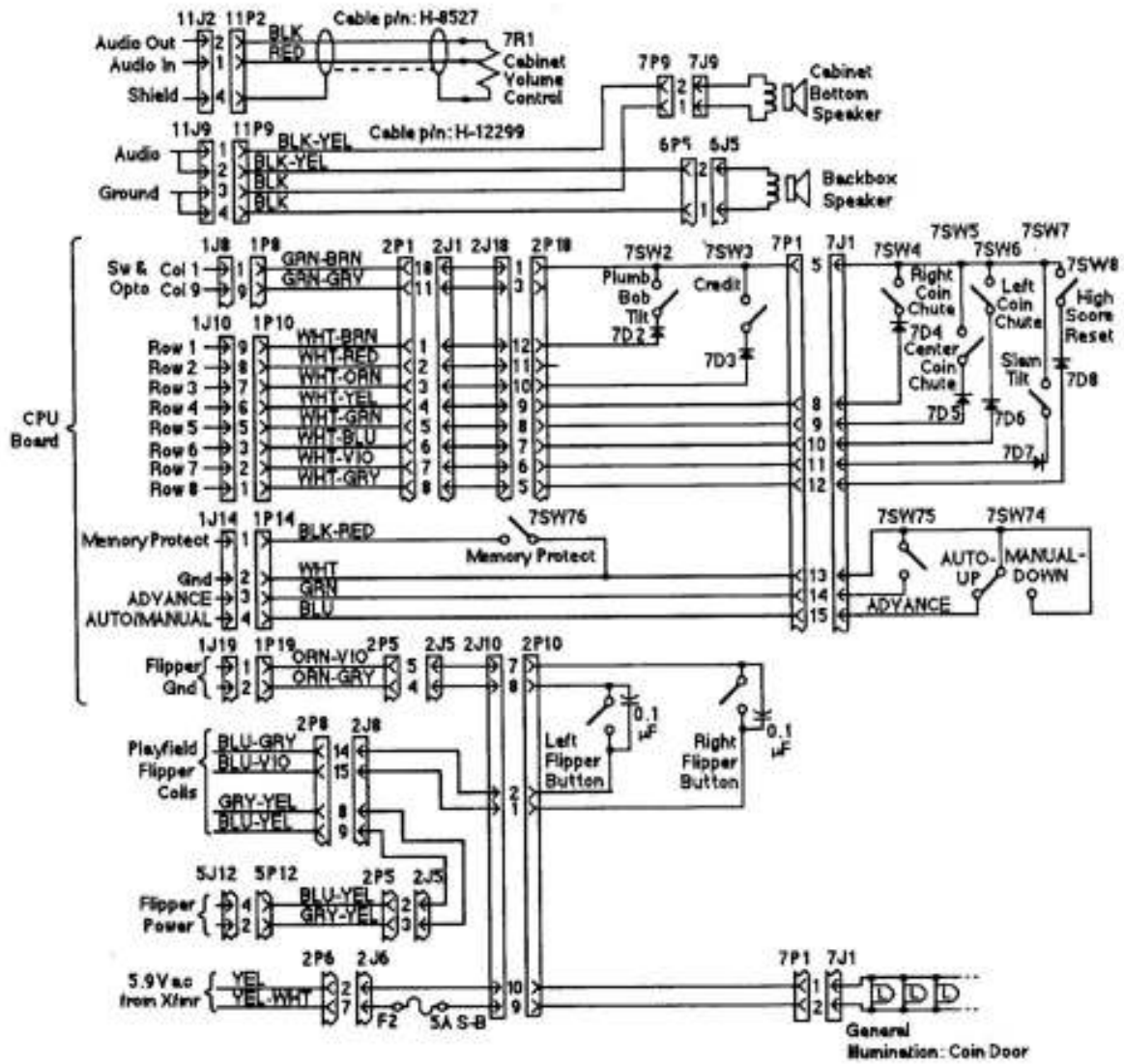

POLICE FORCE Cabinet Wiring

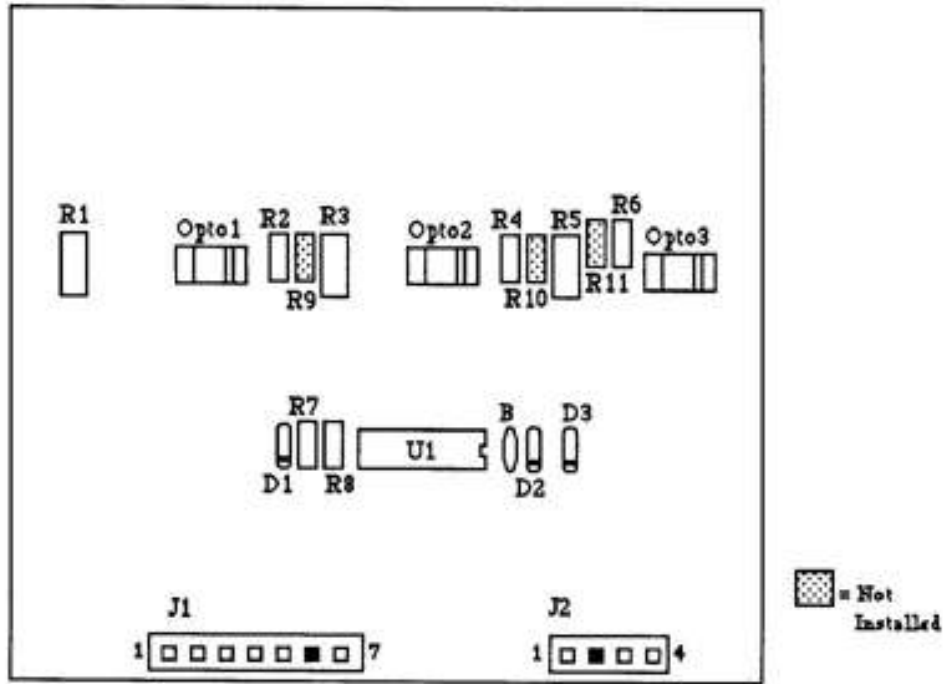

3-Bank Drop Target Opto Board
p/n C-12559

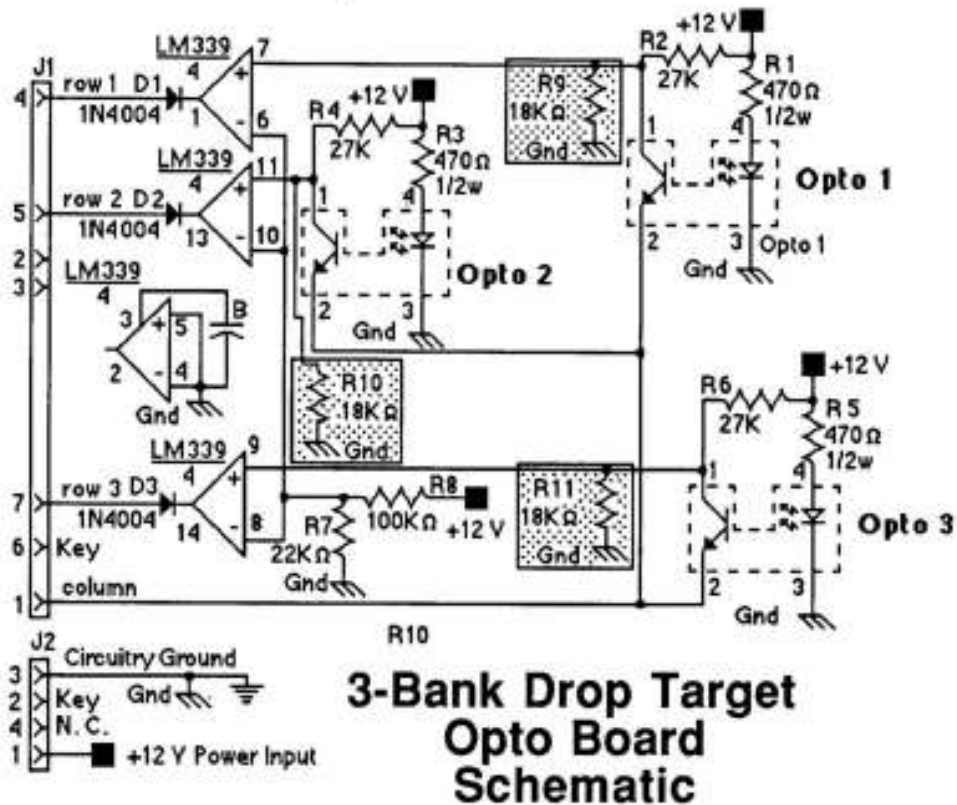

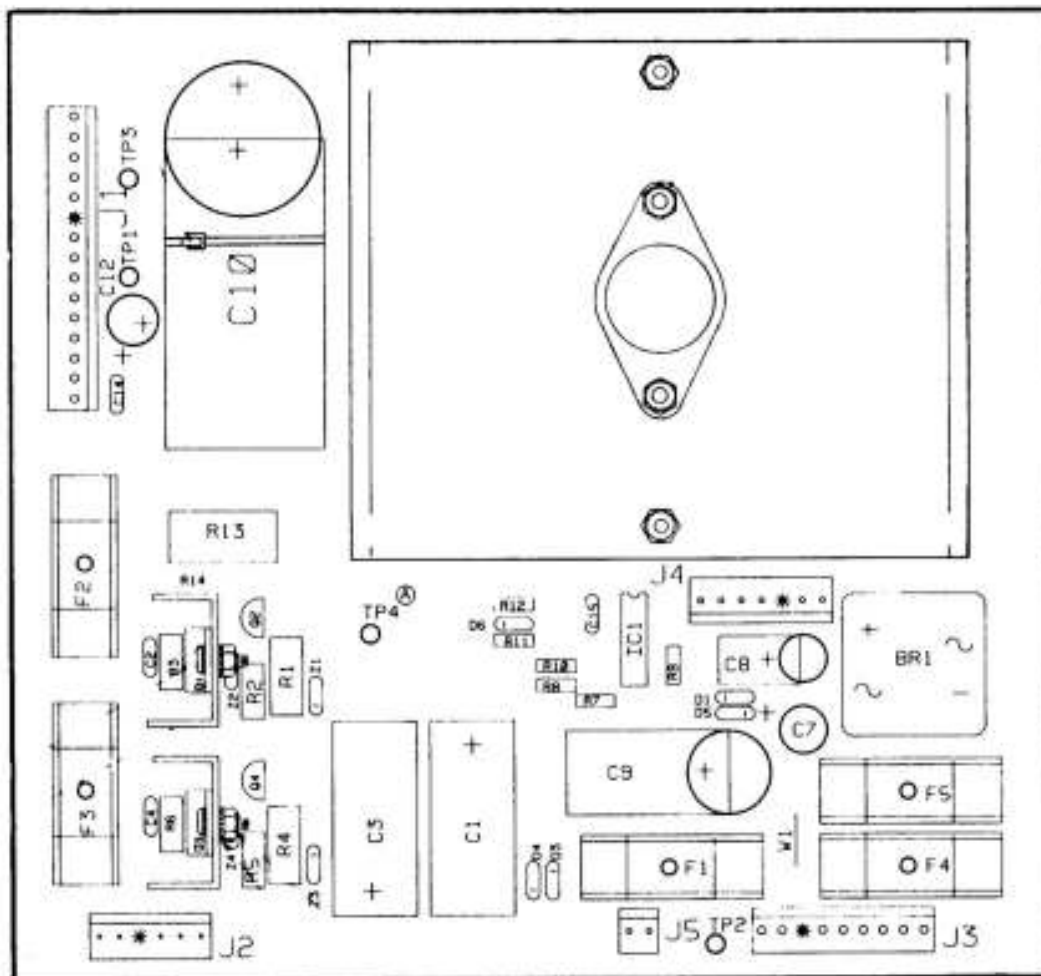

POWER SUPPLY BOARD
 p/n D-12246

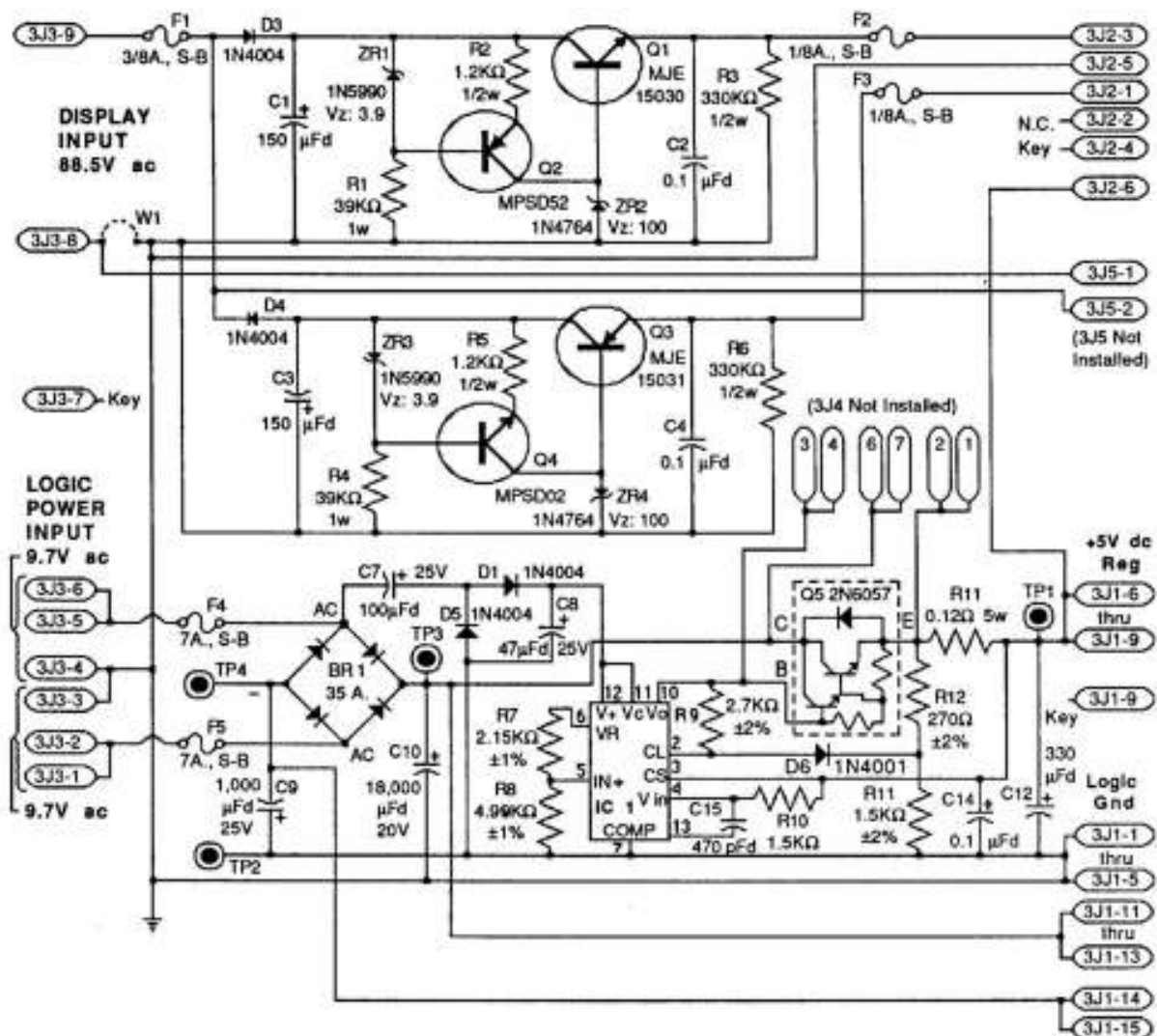

POWER SUPPLY BOARD SCHEMATIC

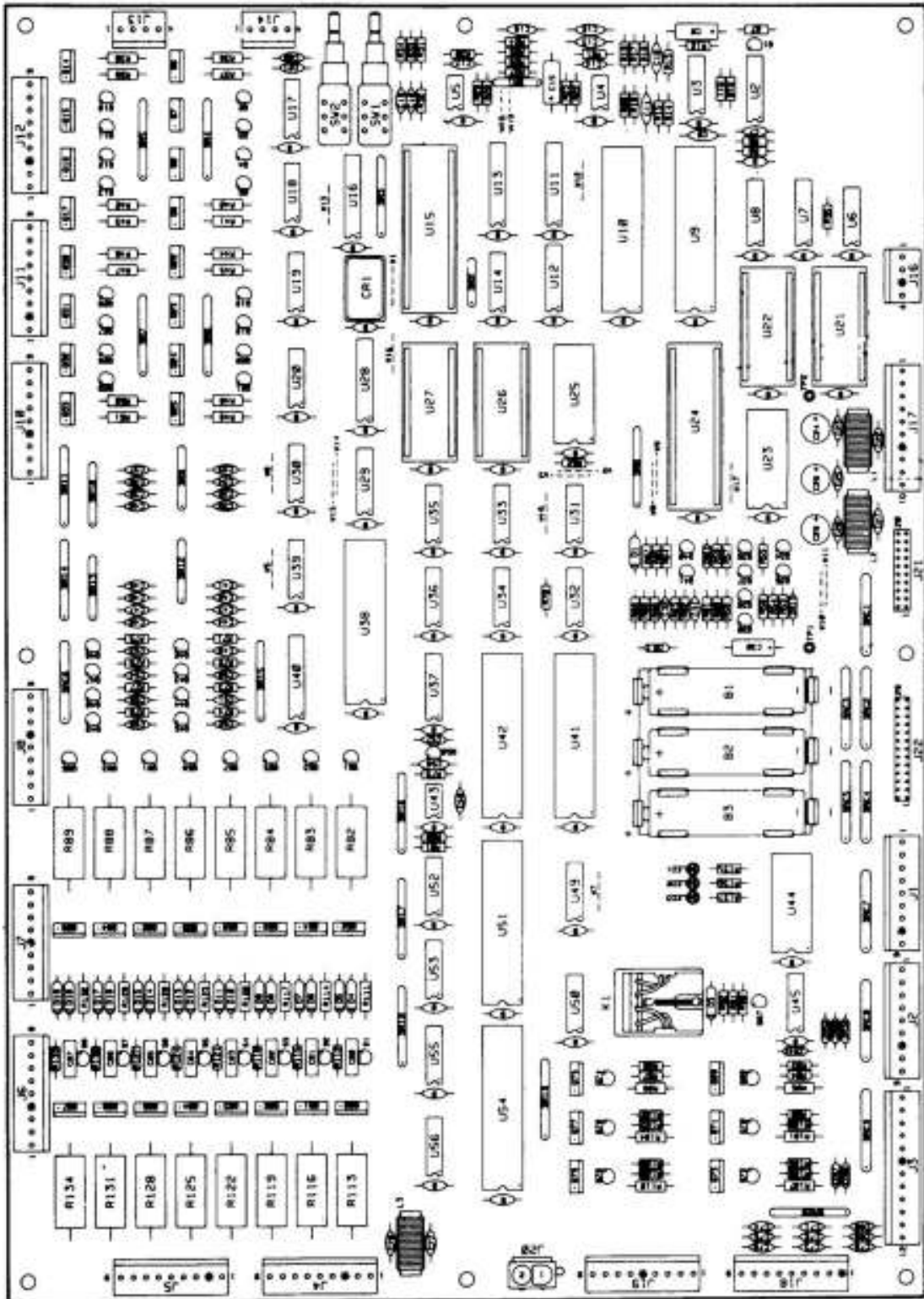

SYSTEM 11B CPU BOARD
 p/n D-11883

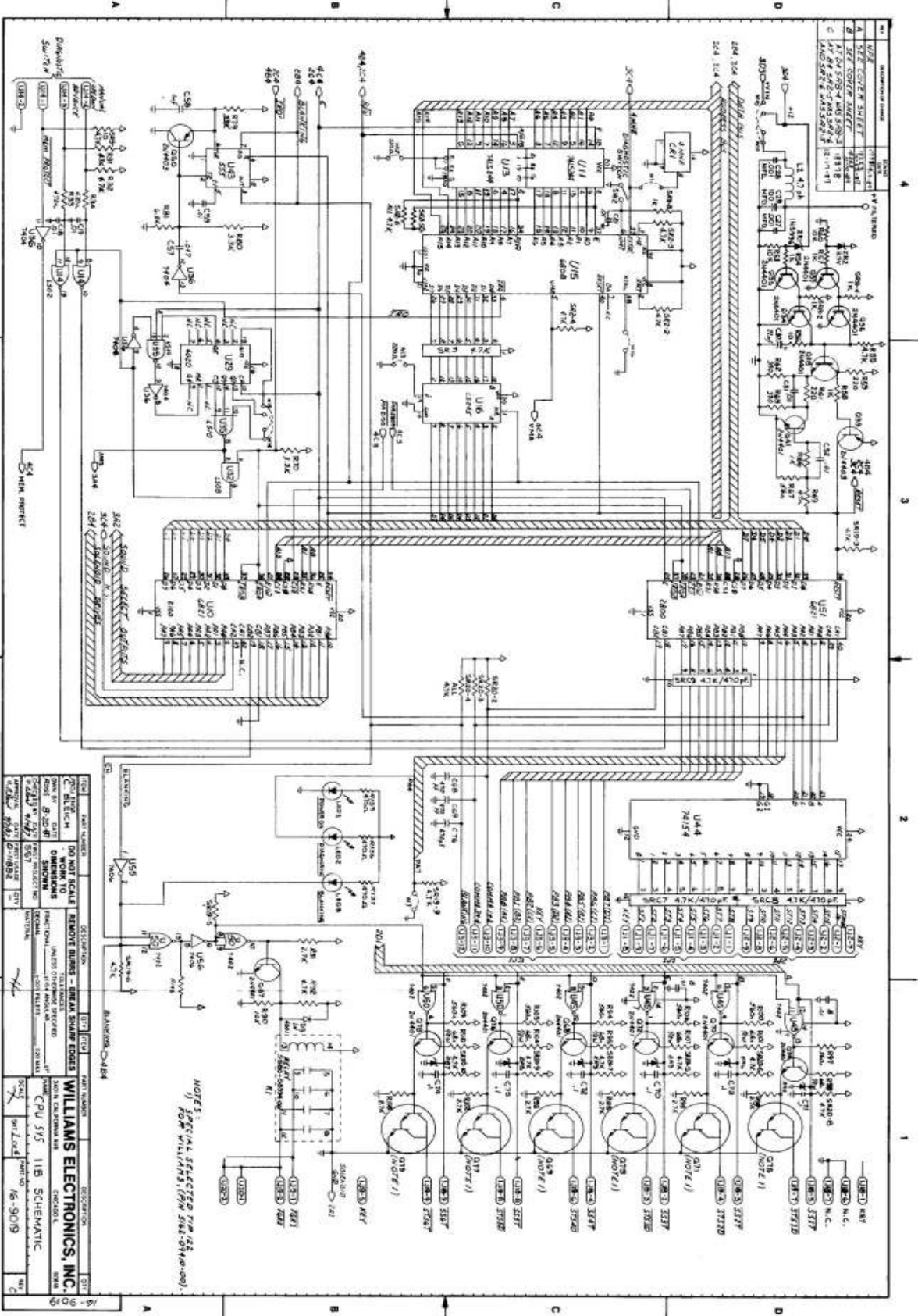

ITEM	QTY	DESCRIPTION	ITEM	QTY	DESCRIPTION
1	1	DO NOT SCALE	1	1	WILLIAMS ELECTRONICS, INC.
2	1	WORK TO DIMENSIONS	2	2	CPU 515 11B SCHEMATIC
3	1	DO NOT SCALE	3	1	16-9019
4	1	WORK TO DIMENSIONS	4	1	
5	1	DO NOT SCALE	5	1	
6	1	WORK TO DIMENSIONS	6	1	

NOTES:
 1) SPECIAL SELECTED FROM 15.
 2) FROM WILLIAMS (704 588-5100).

System 11B CPU Schematic (16-9019, Sheet 1 of 4)

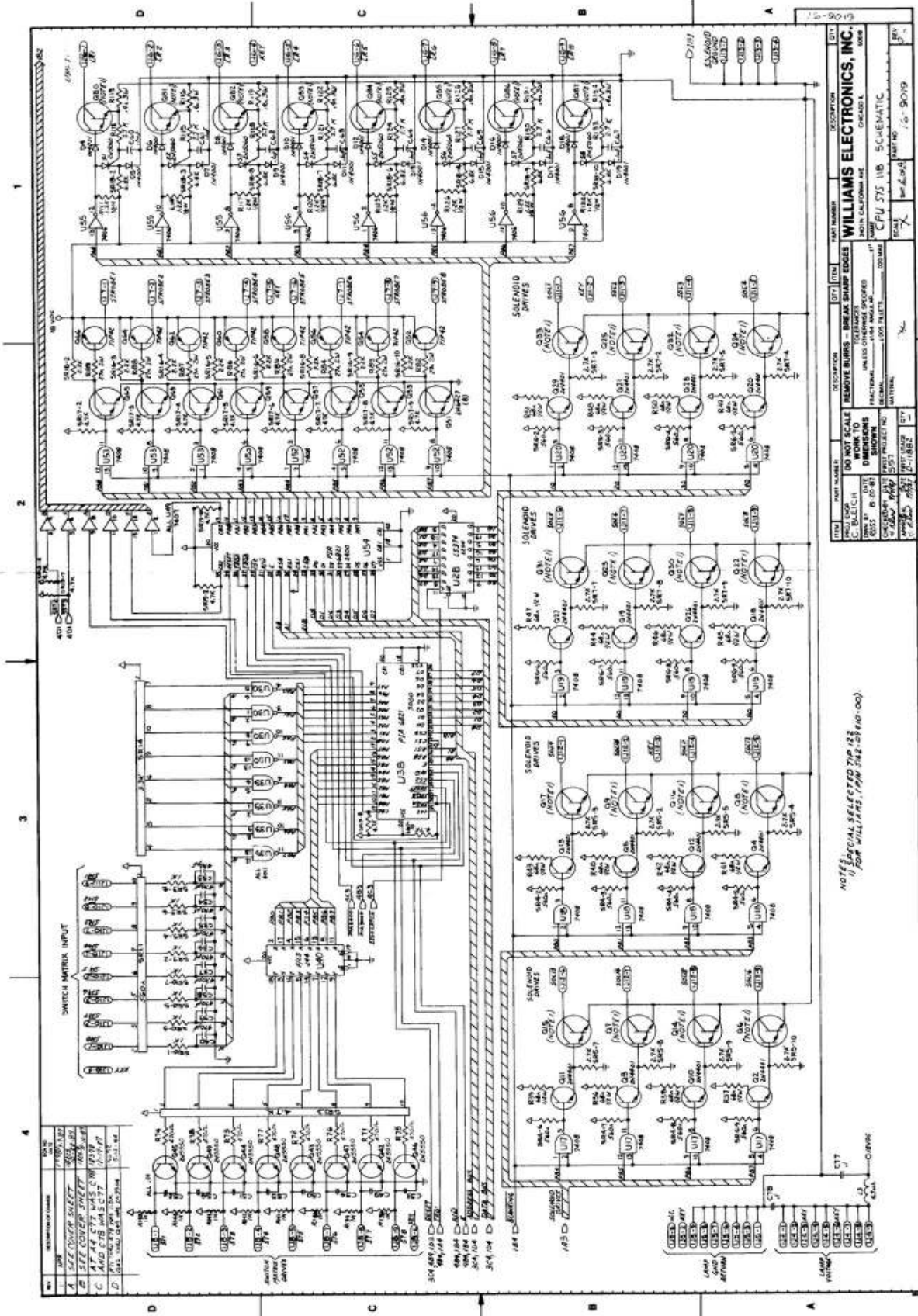

System 11B CPU Schematic (16-9019, Sheet 2 of 4)

POLICE FORCE 84

REV	DATE	DESCRIPTION
1	12-1-73	INITIAL DESIGN
2	12-1-73	REVISED
3	12-1-73	REVISED
4	12-1-73	REVISED

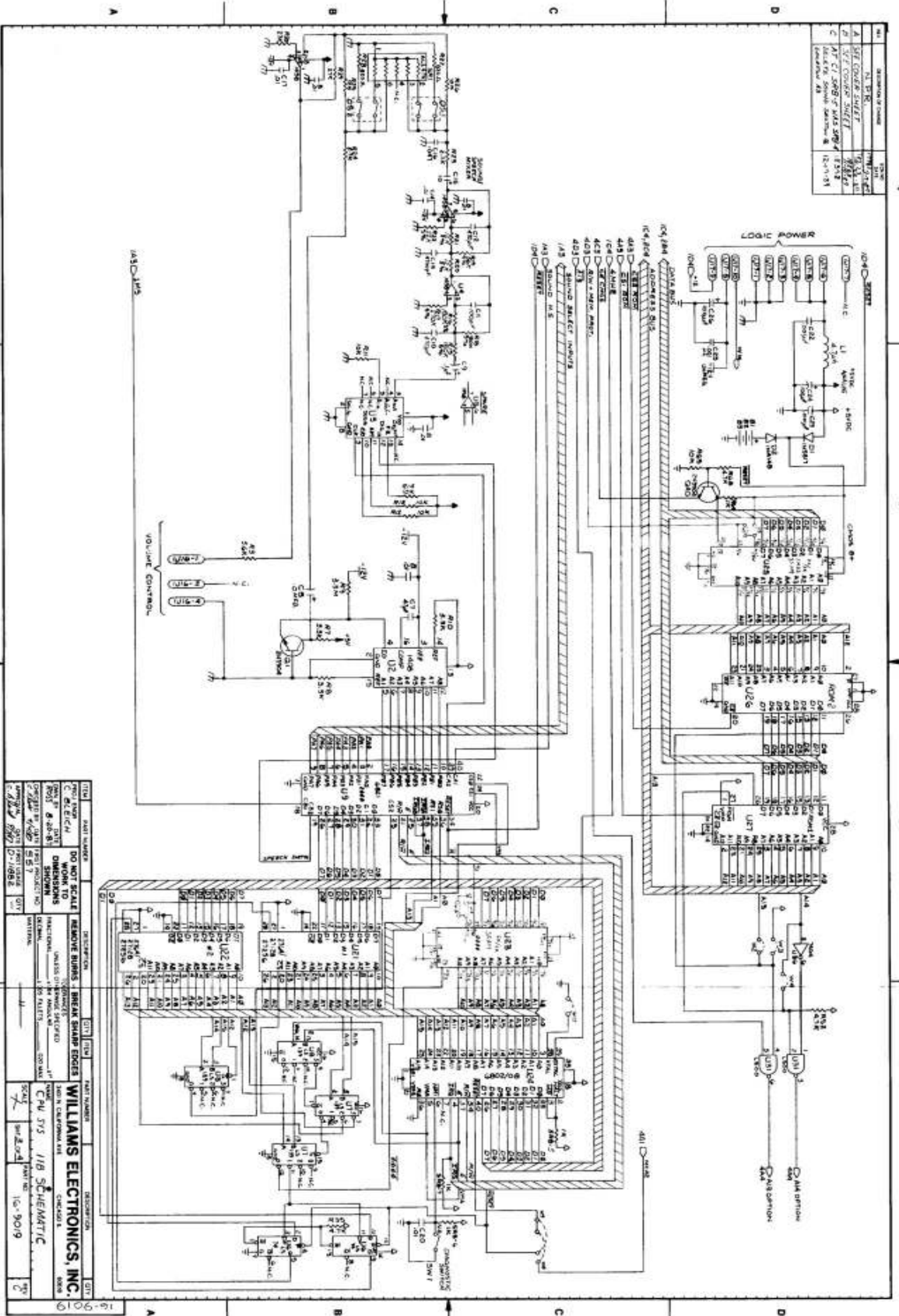

11B	11B	11B	11B	11B	11B	11B	11B	11B	11B
11B	11B	11B	11B	11B	11B	11B	11B	11B	11B
11B	11B	11B	11B	11B	11B	11B	11B	11B	11B
11B	11B	11B	11B	11B	11B	11B	11B	11B	11B
11B	11B	11B	11B	11B	11B	11B	11B	11B	11B
11B	11B	11B	11B	11B	11B	11B	11B	11B	11B
11B	11B	11B	11B	11B	11B	11B	11B	11B	11B
11B	11B	11B	11B	11B	11B	11B	11B	11B	11B
11B	11B	11B	11B	11B	11B	11B	11B	11B	11B
11B	11B	11B	11B	11B	11B	11B	11B	11B	11B

System 11B CPU Schematic (16-9019, Sheet 3 of 4)

REV.	DESCRIPTION OF CHANGE	DATE
1	A. P. R.	10/1/77
A	SEE COVER SHEET	10/1/77
B	SEE COVER SHEET	10/1/77
C	SEE SHEET 1-B	10/1/77

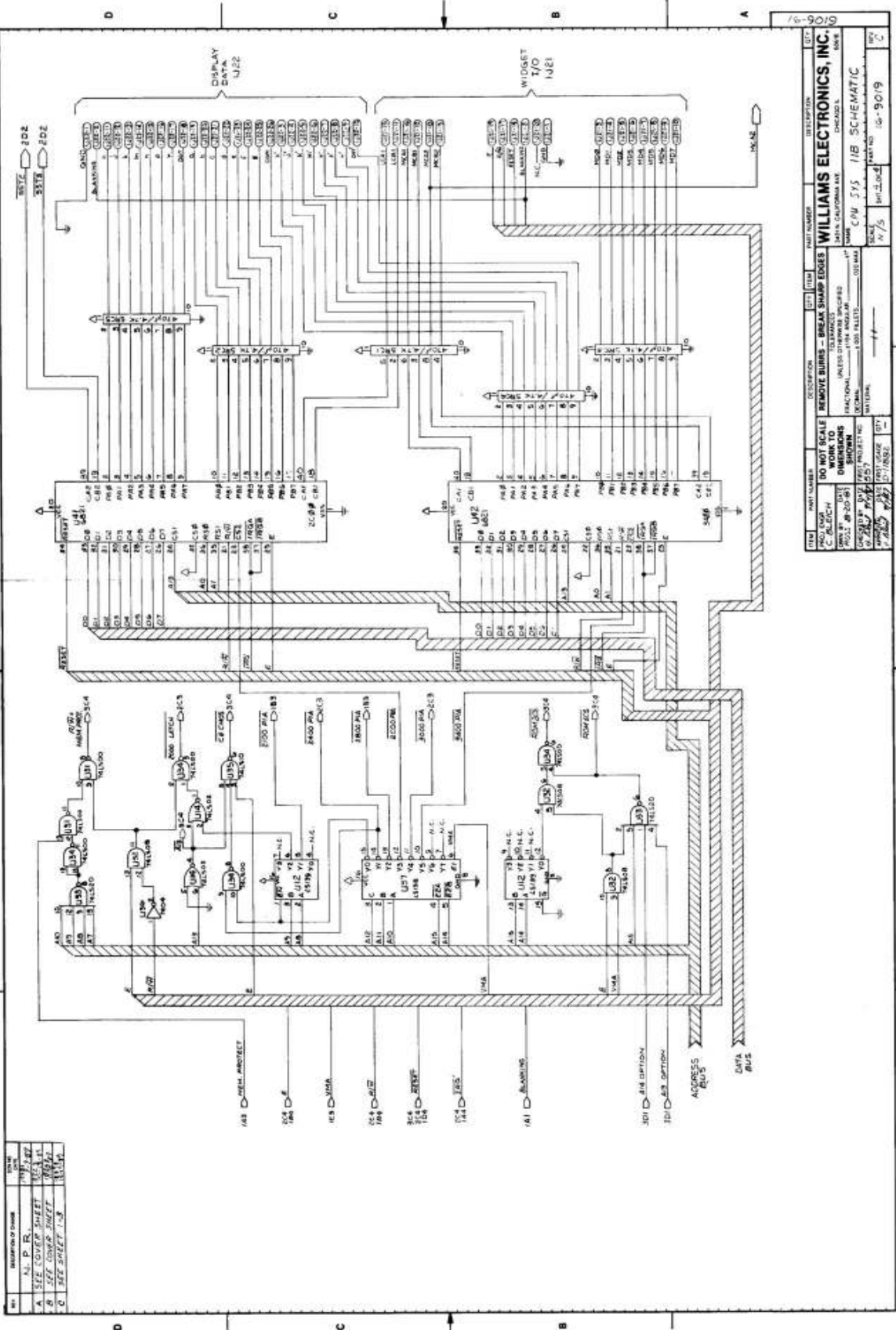

ITEM NO.	11B	REV. NO.	1	DATE	10-9019
DESCRIPTION	REMOVE BUREAU - BRIGIA SHARP EDGES WILLIAMS ELECTRONICS, INC. CHICAGO, ILL.				
DO NOT SCALE WORK TO UNIFORM SHOWN	FRACTIONAL INCHES UNLESS OTHERWISE SPECIFIED				
PROJECT NO.	11B	PROJECT NO.	11B	SCALE	AS SHOWN
DATE	10-9019	DATE	10-9019	BY	C

System 11B CPU Schematic (16-9019, Sheet 4 of 4)

POLICE FORCE 88

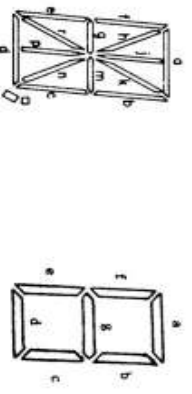
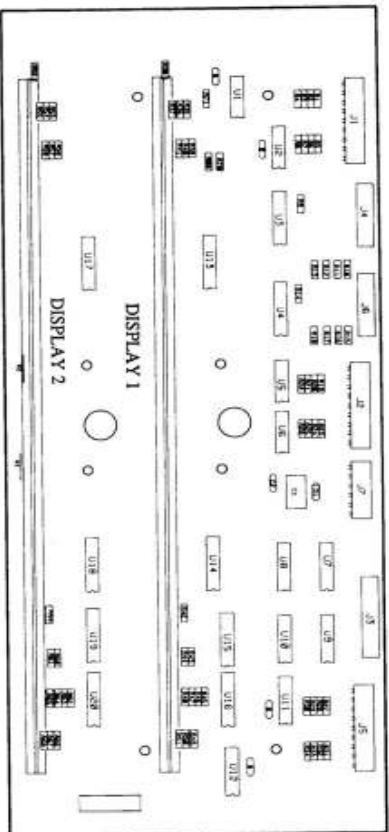

Display Characters Segment Designations

MASTER DISPLAY BOARD
 p/n D-12232-2

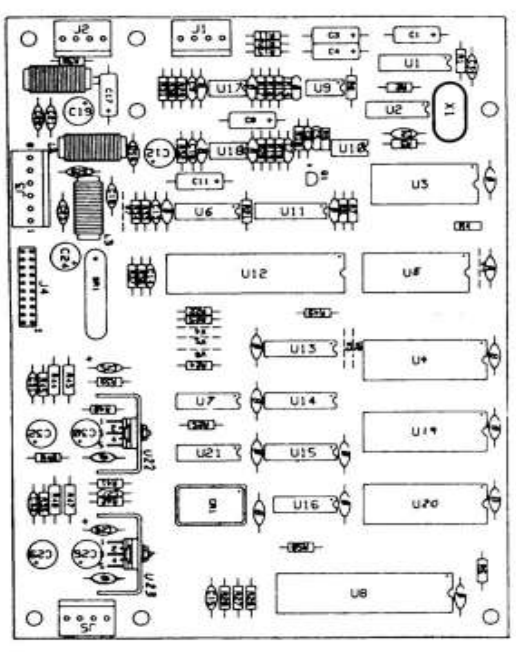

AUDIO BOARD ASSEMBLY
 p/n D-11581-573

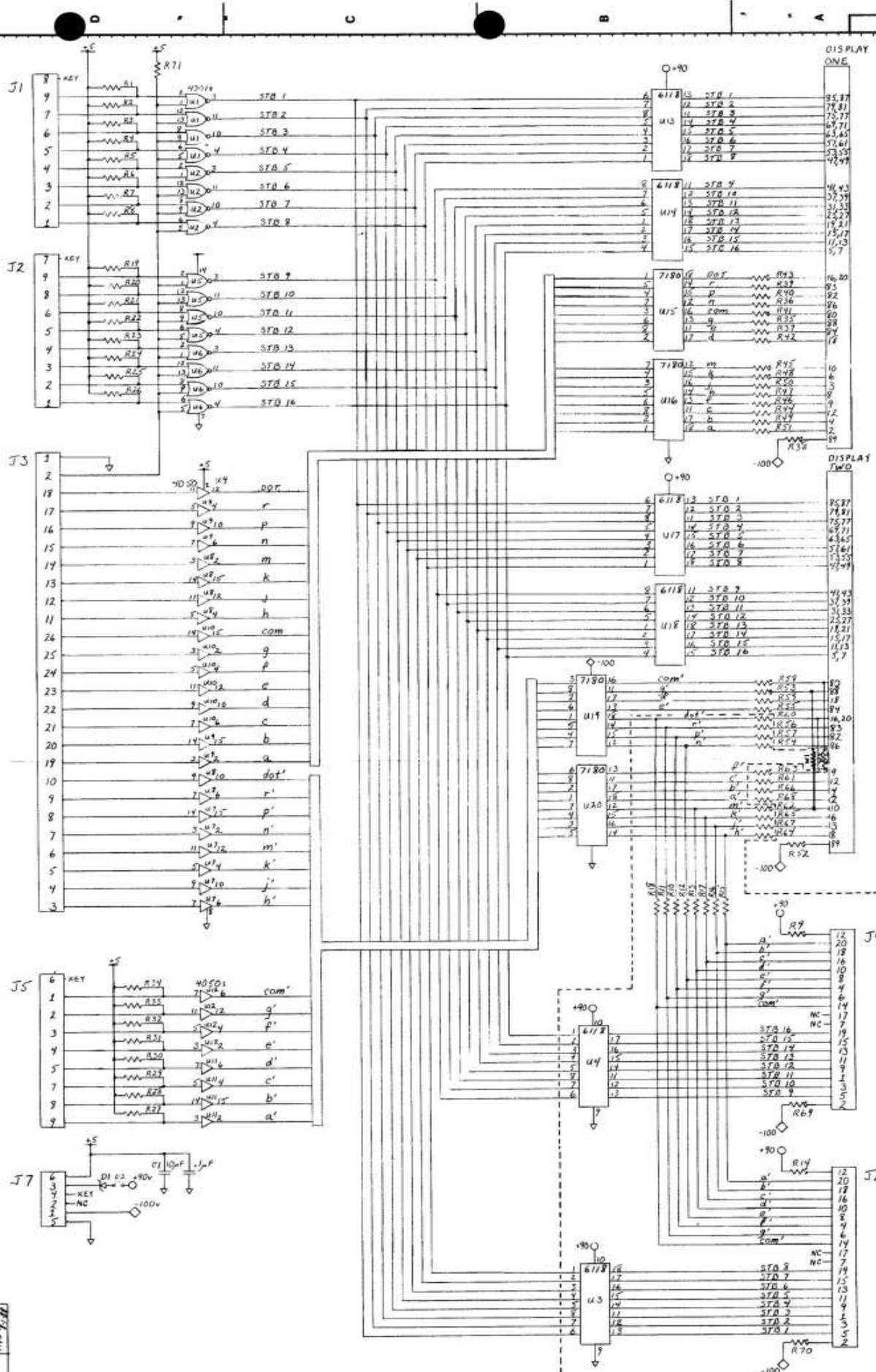

QTY	ITEM	PART NUMBER	DESCRIPTION	REV
1	6118	12	STB 1	85,87
1	6118	13	STB 2	78,81
1	6118	14	STB 3	75,77
1	6118	15	STB 4	69,71
1	6118	16	STB 5	63,65
1	6118	17	STB 6	57,61
1	6118	18	STB 7	51,55
1	6118	19	STB 8	45,49
1	6118	11	STB 9	40,43
1	6118	12	STB 10	34,37
1	6118	13	STB 11	28,31
1	6118	14	STB 12	22,25
1	6118	15	STB 13	16,19
1	6118	16	STB 14	10,13
1	6118	17	STB 15	4,7
1	6118	18	STB 16	0
1	7180	16	dot	16,20
1	7180	17	r	83
1	7180	18	p	82
1	7180	19	com	86
1	7180	13	g	88
1	7180	14	h	89
1	7180	15	i	90
1	7180	12	m	94
1	7180	11	n	95
1	7180	10	dot'	96
1	7180	9	r'	97
1	7180	8	p'	98
1	7180	7	n'	99
1	7180	6	m'	100
1	7180	5	k'	101
1	7180	4	j'	102
1	7180	3	h'	103

ITEM	PART NUMBER	DESCRIPTION	QTY	REV
1	6118	12	STB 1	85,87
1	6118	13	STB 2	78,81
1	6118	14	STB 3	75,77
1	6118	15	STB 4	69,71
1	6118	16	STB 5	63,65
1	6118	17	STB 6	57,61
1	6118	18	STB 7	51,55
1	6118	19	STB 8	45,49
1	6118	11	STB 9	40,43
1	6118	12	STB 10	34,37
1	6118	13	STB 11	28,31
1	6118	14	STB 12	22,25
1	6118	15	STB 13	16,19
1	6118	16	STB 14	10,13
1	6118	17	STB 15	4,7
1	6118	18	STB 16	0
1	7180	16	com'	82
1	7180	17	dot'	83
1	7180	18	r'	84
1	7180	19	p'	85
1	7180	13	g'	86
1	7180	14	h'	87
1	7180	15	i'	88
1	7180	12	m'	89
1	7180	11	n'	90
1	7180	10	dot'	91
1	7180	9	r'	92
1	7180	8	p'	93
1	7180	7	n'	94
1	7180	6	m'	95
1	7180	5	k'	96
1	7180	4	j'	97
1	7180	3	h'	98

FOR USAGE OF THESE COMPONENTS
REFER TO ASSEMBLY DRAWING D-12159

WILLIAMS ELECTRONICS, INC.
3030 CALIFORNIA AVE
CHICAGO, ILL. 60608
NAME: MASTER DISPLAY 88 - SCHEMATIC
SCALE: 1/16" = 1"

POLICE FORCE 88

REVISIONS
DATE: 11/1/73
BY: NFR

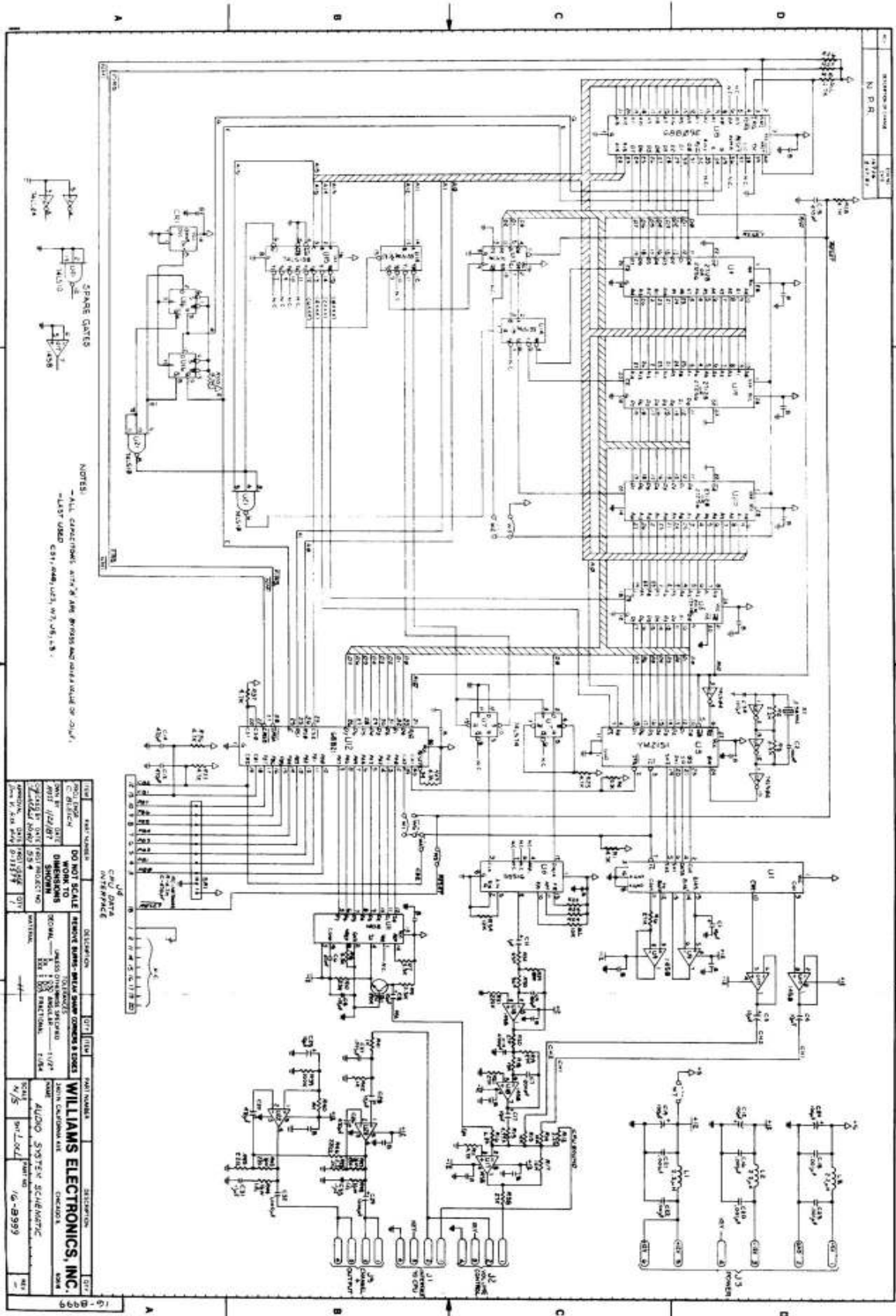

NOTES:
 - ALL CAPACITORS ARE W.M. BRASS AND POLYESTER OR OIL.
 - LST USED C31+444, 443 W7, 451, 5.

REV	DATE	BY	DESCRIPTION
1	1/2/87	WJS	REVISED TO ADD TAPES
2	1/2/87	WJS	REVISED TO ADD TAPES
3	1/2/87	WJS	REVISED TO ADD TAPES
4	1/2/87	WJS	REVISED TO ADD TAPES
5	1/2/87	WJS	REVISED TO ADD TAPES
6	1/2/87	WJS	REVISED TO ADD TAPES
7	1/2/87	WJS	REVISED TO ADD TAPES
8	1/2/87	WJS	REVISED TO ADD TAPES
9	1/2/87	WJS	REVISED TO ADD TAPES
10	1/2/87	WJS	REVISED TO ADD TAPES

Audio Board (D-11581) Schematic

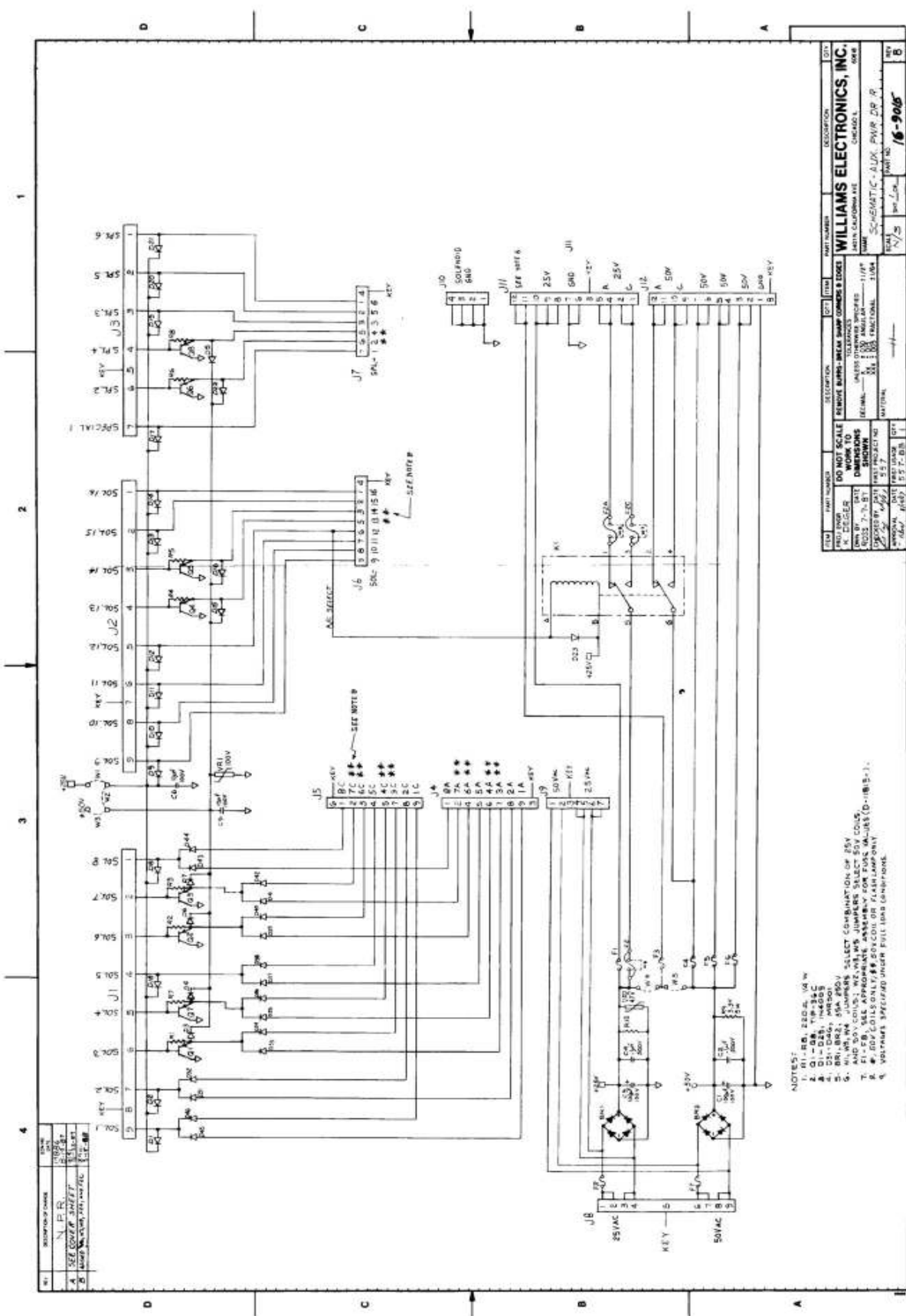

REV	DESCRIPTION OF CHANGE	DATE
1	ASSEMBLED	11/15/68
2	SEE COVER SHEET	11/15/68
3	ASSEMBLED	11/15/68
4	ASSEMBLED	11/15/68

REV	DATE	DESCRIPTION
1	11/15/68	ASSEMBLED
2	11/15/68	SEE COVER SHEET
3	11/15/68	ASSEMBLED
4	11/15/68	ASSEMBLED

REV	DATE	DESCRIPTION
1	11/15/68	ASSEMBLED
2	11/15/68	SEE COVER SHEET
3	11/15/68	ASSEMBLED
4	11/15/68	ASSEMBLED

Aux Power Driver Board Schematic

POLICE FORCE 80

- NOTES:
1. R1 - 1/2W, 100Ω
 2. D1 - 1N4001, 100V
 3. D2 - 1N4001, 100V
 4. D3 - 1N4001, 100V
 5. D4 - 1N4001, 100V
 6. D5 - 1N4001, 100V
 7. D6 - 1N4001, 100V
 8. D7 - 1N4001, 100V
 9. D8 - 1N4001, 100V
 10. D9 - 1N4001, 100V
 11. D10 - 1N4001, 100V
 12. D11 - 1N4001, 100V
 13. D12 - 1N4001, 100V
 14. D13 - 1N4001, 100V
 15. D14 - 1N4001, 100V
 16. D15 - 1N4001, 100V
 17. D16 - 1N4001, 100V
 18. D17 - 1N4001, 100V
 19. D18 - 1N4001, 100V
 20. D19 - 1N4001, 100V
 21. D20 - 1N4001, 100V
 22. D21 - 1N4001, 100V
 23. D22 - 1N4001, 100V
 24. D23 - 1N4001, 100V
 25. D24 - 1N4001, 100V
 26. D25 - 1N4001, 100V
 27. D26 - 1N4001, 100V
 28. D27 - 1N4001, 100V
 29. D28 - 1N4001, 100V
 30. D29 - 1N4001, 100V
 31. D30 - 1N4001, 100V
 32. D31 - 1N4001, 100V
 33. D32 - 1N4001, 100V
 34. D33 - 1N4001, 100V
 35. D34 - 1N4001, 100V
 36. D35 - 1N4001, 100V
 37. D36 - 1N4001, 100V
 38. D37 - 1N4001, 100V
 39. D38 - 1N4001, 100V
 40. D39 - 1N4001, 100V
 41. D40 - 1N4001, 100V
 42. D41 - 1N4001, 100V
 43. D42 - 1N4001, 100V
 44. D43 - 1N4001, 100V
 45. D44 - 1N4001, 100V
 46. D45 - 1N4001, 100V
 47. D46 - 1N4001, 100V
 48. D47 - 1N4001, 100V
 49. D48 - 1N4001, 100V
 50. D49 - 1N4001, 100V
 51. D50 - 1N4001, 100V
 52. D51 - 1N4001, 100V
 53. D52 - 1N4001, 100V
 54. D53 - 1N4001, 100V
 55. D54 - 1N4001, 100V
 56. D55 - 1N4001, 100V
 57. D56 - 1N4001, 100V
 58. D57 - 1N4001, 100V
 59. D58 - 1N4001, 100V
 60. D59 - 1N4001, 100V
 61. D60 - 1N4001, 100V
 62. D61 - 1N4001, 100V
 63. D62 - 1N4001, 100V
 64. D63 - 1N4001, 100V
 65. D64 - 1N4001, 100V
 66. D65 - 1N4001, 100V
 67. D66 - 1N4001, 100V
 68. D67 - 1N4001, 100V
 69. D68 - 1N4001, 100V
 70. D69 - 1N4001, 100V
 71. D70 - 1N4001, 100V
 72. D71 - 1N4001, 100V
 73. D72 - 1N4001, 100V
 74. D73 - 1N4001, 100V
 75. D74 - 1N4001, 100V
 76. D75 - 1N4001, 100V
 77. D76 - 1N4001, 100V
 78. D77 - 1N4001, 100V
 79. D78 - 1N4001, 100V
 80. D79 - 1N4001, 100V
 81. D80 - 1N4001, 100V
 82. D81 - 1N4001, 100V
 83. D82 - 1N4001, 100V
 84. D83 - 1N4001, 100V
 85. D84 - 1N4001, 100V
 86. D85 - 1N4001, 100V
 87. D86 - 1N4001, 100V
 88. D87 - 1N4001, 100V
 89. D88 - 1N4001, 100V
 90. D89 - 1N4001, 100V
 91. D90 - 1N4001, 100V
 92. D91 - 1N4001, 100V
 93. D92 - 1N4001, 100V
 94. D93 - 1N4001, 100V
 95. D94 - 1N4001, 100V
 96. D95 - 1N4001, 100V
 97. D96 - 1N4001, 100V
 98. D97 - 1N4001, 100V
 99. D98 - 1N4001, 100V
 100. D99 - 1N4001, 100V
 101. D100 - 1N4001, 100V

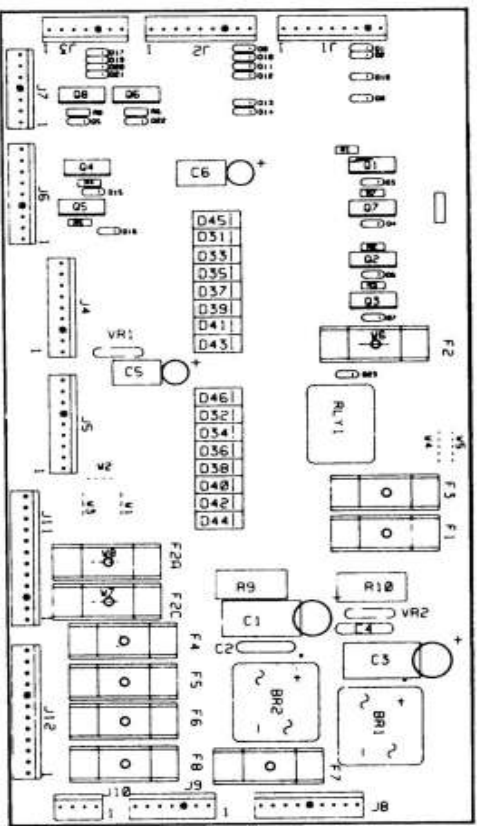

AUX POWER DRIVER UNIT BOARD
 p/n D-12247

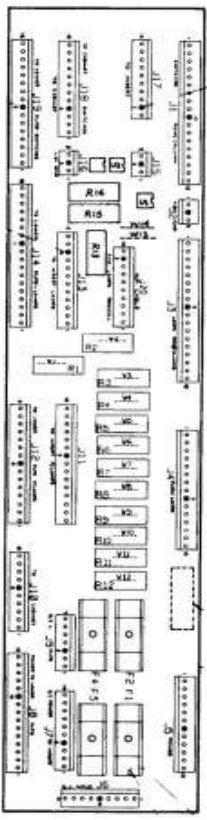

BACKBOX INTERCONNECT BOARD
 p/n D-12313-573

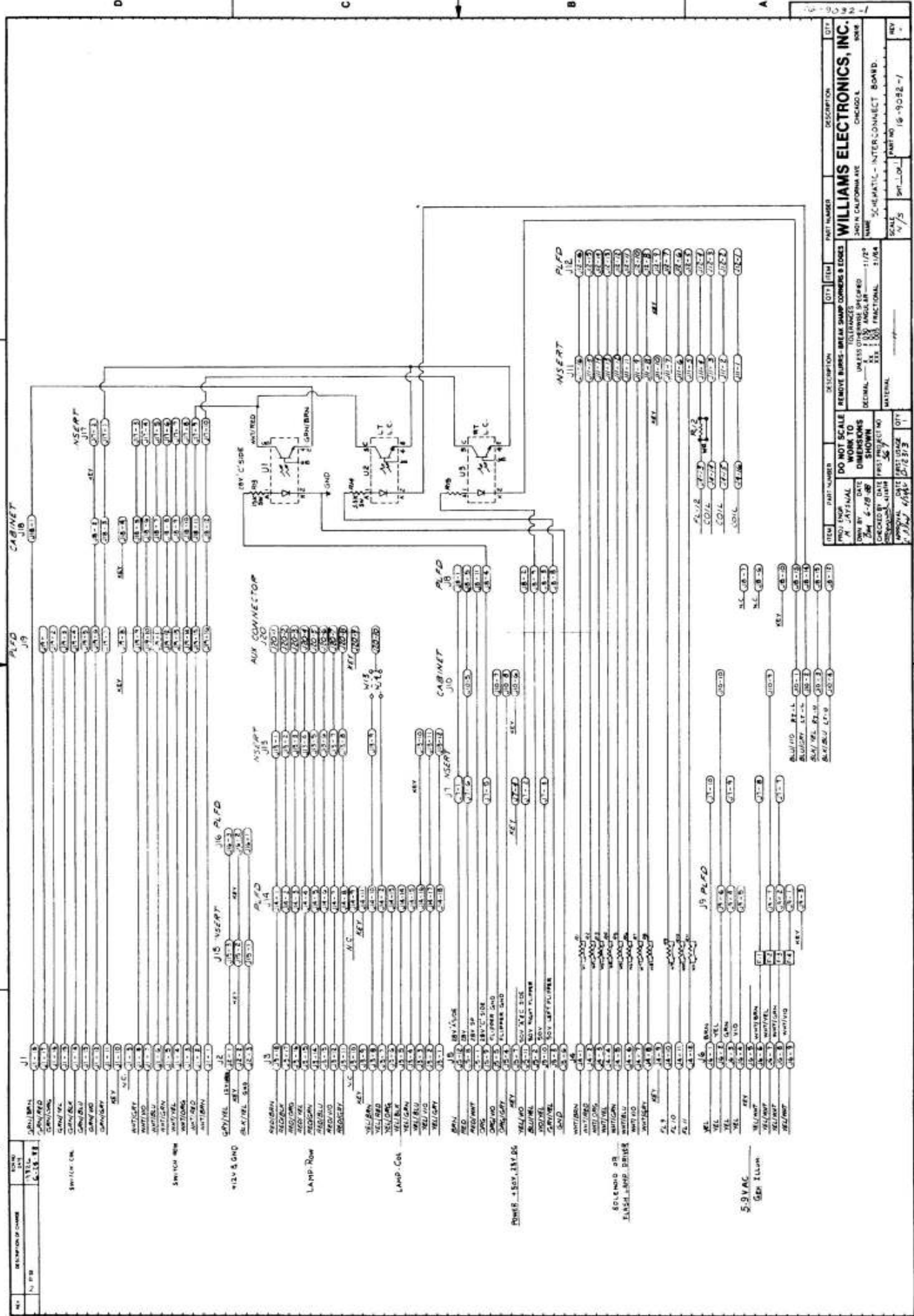

ITEM	PART NUMBER	DESCRIPTION	QTY	U/M	PART NUMBER	DESCRIPTION	QTY
PRO. INSP.		DO NOT SCALE			REMOVABLE BREAK SWAMP CONNECTOR'S ESDS		
PRO. DES.		WORK TO			ILLUMINATED		
DES. DATE	4-18-88	DESIGNER'S			UNLESS OTHERWISE		
CHECKED BY	DATE	PROJECT NO.			DECIMAL	1.00	ANGLES IN
APPROVAL	DATE	SCALE			FRACTIONAL	1/8"	
		MATERIAL					
		SCALE					
		SCALE					

WILLIAMS ELECTRONICS, INC.
 300 N. CALIFORNIA AVE.
 CHICAGO, ILL. 60644
 SCHEMATIC - INTERCONNECT BOARD
 16-9082-7

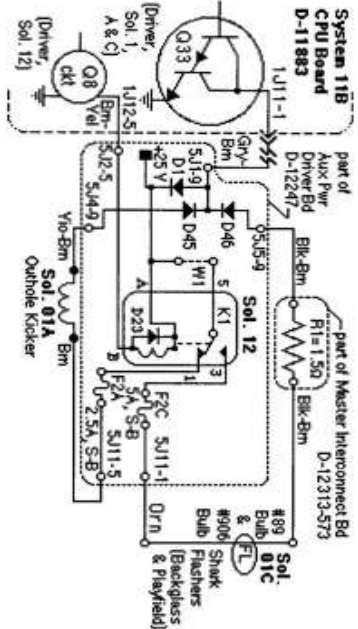
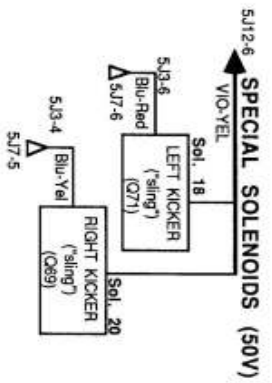
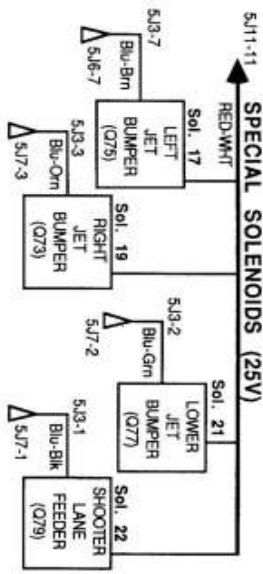
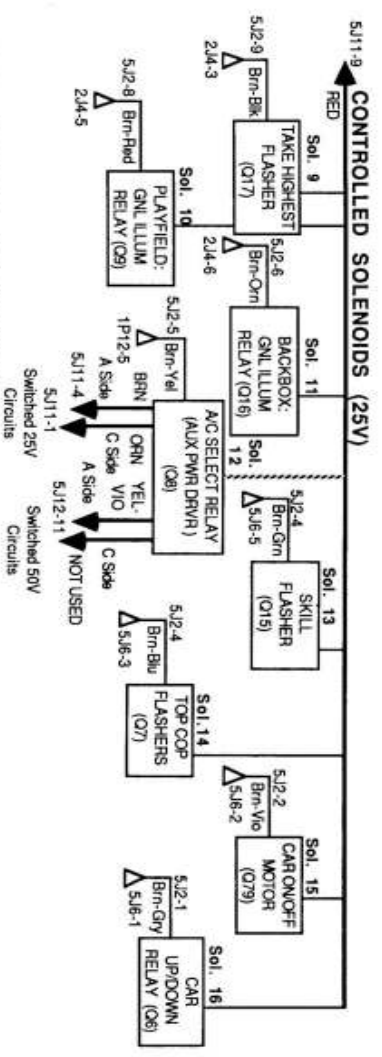

Typical A/C Select (Switched Solenoid) Circuit

SWITCHED SOLENOIDS

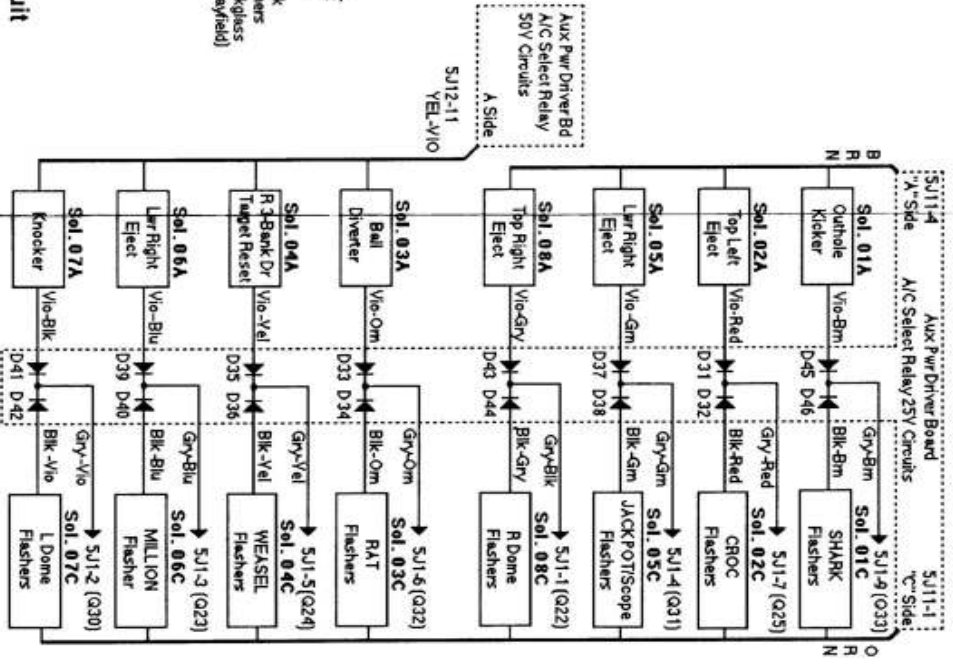

CONTROLLED, SPECIAL, & SWITCHED SOLENOIDS

Diagnostic Test Flowchart

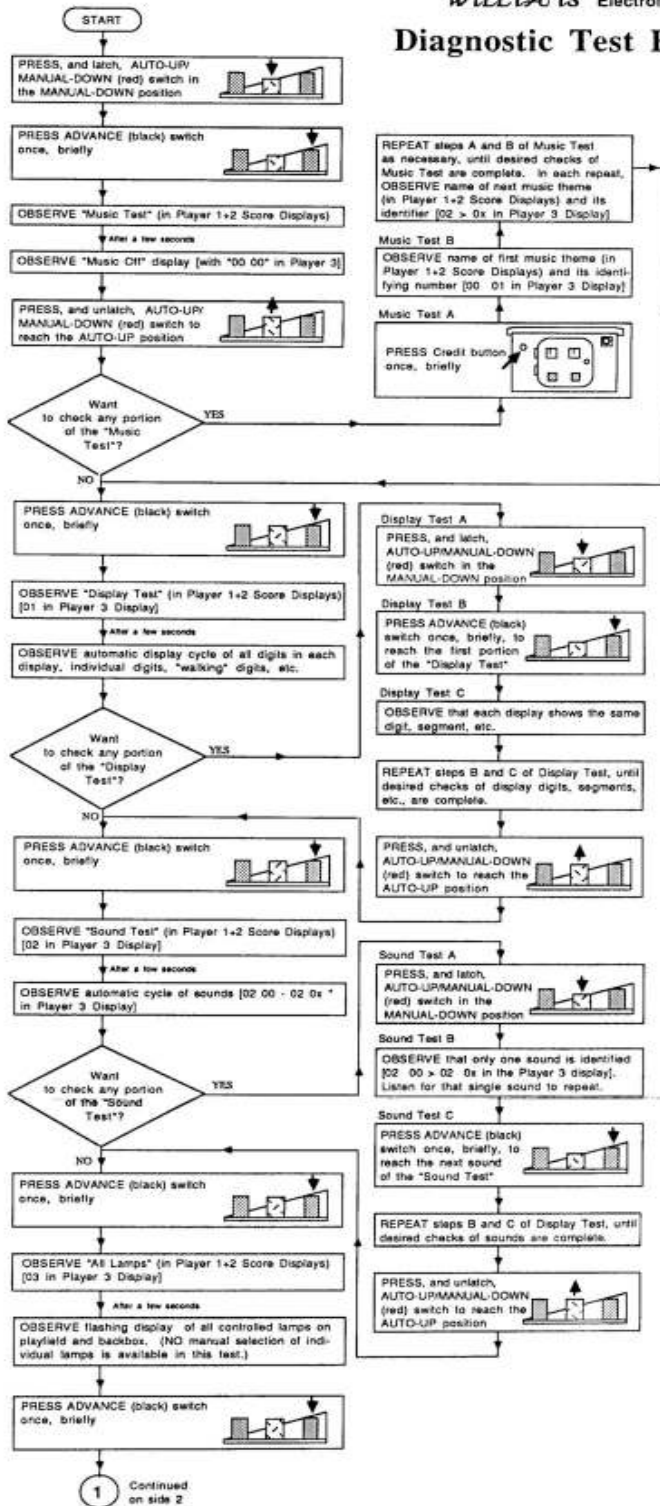

DIAGNOSTIC TEST FLOWCHART (SIDE 1)

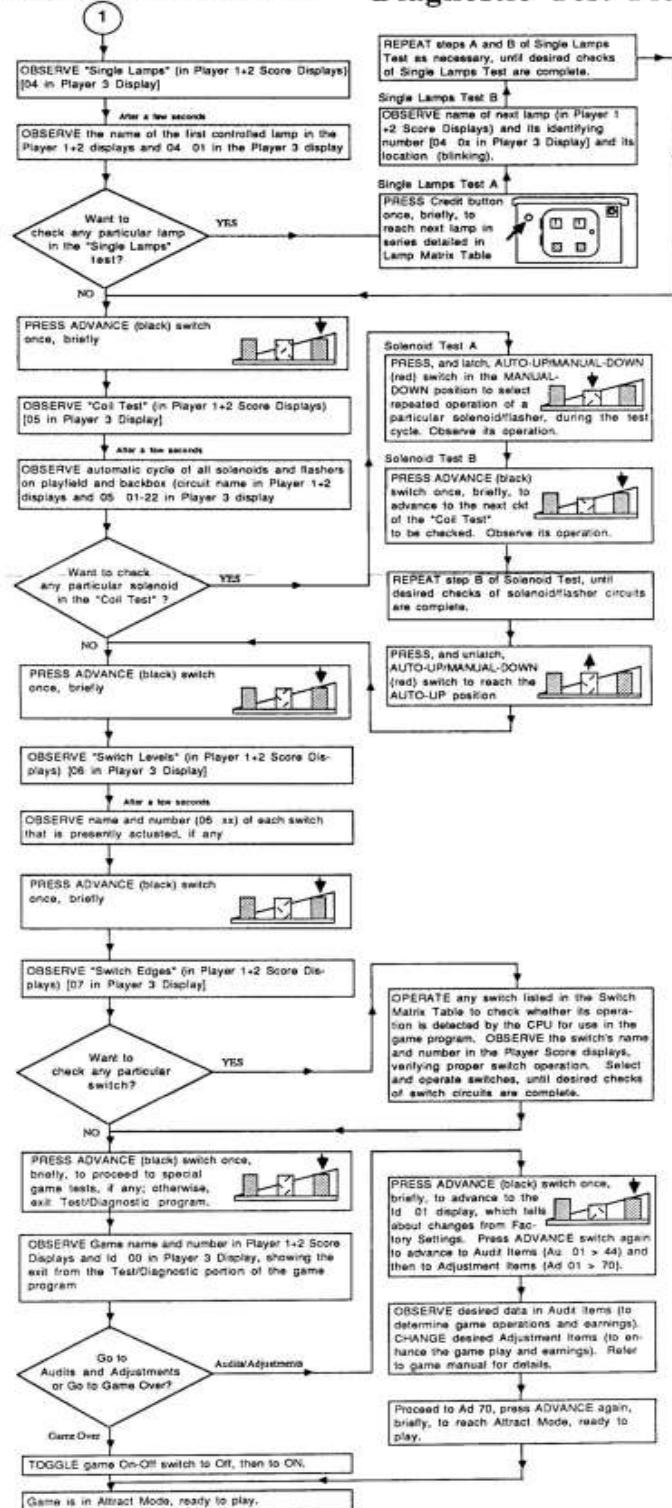

POLICE FORCE Lamp-Matrix Table

COLUMN	1 Q66 YEL-BRN 1J7-1	2 Q64 YEL-RED 1J7-2	3 Q62 YEL-ORN 1J7-3	4 Q60 YEL-BLK 1J7-4	5 Q58 YEL-GRN 1J7-6	6 Q56 YEL-BLU 1J7-7	7 Q54 YEL-VIO 1J7-8	8 Q52 YEL-GRY 1J7-9
Q80 RED-BRN 1J6-1	Hot Sheet Hot Score 1	2X 9	P 17	10k (Mdl Ramp) 25	Shark 33	Jackpot W/L 41	Right Outlane 49	L 3-Bank Stndup Tgt (upr) 57
Q81 RED-BLK 1J6-2	Hot Sheet Extra Ball 2	3X 10	O 18	20k (Mdl Ramp) 26	Croc 34	Skill 10K (Firing Range) 42	Left Outlane 50	L 3-Bank Stndup Tgt (mdl) 58
Q82 RED-ORN 1J6-3	Hot Sheet 5 Free Games 3	4X 11	L 19	50k (Mdl Ramp) 27	Drug Rat 35	Skill 25K (Firing Range) 43	Left Return 51	L 3-Bank Stndup Tgt (lwr) 59
Q83 RED-YE 1J6-5	Hot Sheet Multi-Ball 4	5X 12	I 20	75k (Mdl Ramp) 28	Weasel 36	Skill 50K (Firing Range) 44	Right Return 52	Scope (Backglass) 60
Q84 RED-GRN 1J6-6	Hot Sheet Spot P-O-L-I-C-E 5	6X 13	C 21	100k (Mdl Ramp) 29	Shark In Jail 37	Skill 75K (Firing Range) 45	Take Highest 53	L Jackpot (Backglass) 61
Q85 RED-BLU 1J6-7	Spot Police 6	Special W/L 14	E 22	150k (Mdl Ramp) 30	Croc In Jail 38	Skill 100K (Firing Range) 46	G 54	R Jackpot (Backglass) 62
Q86 RED-VIO 1J6-8	Lock 1 7	HotSheet Bonus W/L 15	Top Extra Ball 23	Unlimited Million W/L 31	Drug Rat In Jail 39	Car Headlight 47	U 55	L Dome (Backglass) 63
Q87 RED-GRY 1J6-9	Lock 2 8	Adv. Handoff Bonus 16	Shoot Again 24	Top Cop Bonus 32	Weasel In Jail 40	Car Headlight 48	N 56	R Dome (Backglass) 64

POLICE FORCE Switch-Matrix Table

COLUMN	1 Q45 GRN-BRN 1J8-1	2 Q49 GRN-RED 1J8-2	3 Q44 GRN-ORN 1J8-3	4 Q48 GRN-YEL 1J8-4	5 Q43 GRN-BLK 1J8-5	6 Q47 GRN-BLU 1J8-7	7 Q42 GRN-VIO 1J8-8	8 Q46 GRN-GRY 1J8-9
1 WHT-BRN 1J10-9	Plumb Bob Tilt 1	Playfield Tilt 9	L 3-Bank Stndup Tgt (upr) 17	Mid 3-Bank Dr Target (upr) 25	33	SkillSwitch (Spinner) 41	Right -Outlane 49	Flipper Right 57
2 WHT-RED 1J10-8	C Side Power A/C Relay 2	Outhole 10	L 3-Bank Stndup Tgt (mid) 18	Mid 3-Bank Dr Target (mid) 26	Enter Right Ramp 34	42	Left Outlane 50	Flipper Left 58
3 WHT-ORN 1J10-7	Credit Button 3	Ball Trough #1 (R) 11	L 3-Bank Stndup Tgt (lwr) 19	Mid 3-Bank Dr Target (lwr) 27	Top Left Tgt (Top Cop) 35	43	Left Return Lane 51	59
4 WHT-YEL 1J10-6	Right Coin Chute 4	Ball Trough #2 (L) 12	R 3-Bank Dr Target (upr) 20	28	Diverter In 36	44	Right Return Lane 52	Left Jet Bumper 60
5 WHT-GRN 1J10-5	Center Coin Chute 5	13	R 3-Bank Dr Target (mid) 21	29	R Ramp to Car 37	Enter Mdl Ramp 45	53	Right Jet Bumper 61
6 WHT-BLU 1J10-3	Left Coin Chute 6	Ball Shooter 14	R 3-Bank Dr Target (lwr) 22	30	R Ramp to Wire 38	Mdl Ramp Score 46	G 54	Lwr Jet Bumper 62
7 WHT-VIO 1J10-2	Slam Tilt 7	Top Right Eject 15	BR Eject 23	Car Up 31	39	47	U 55	BL Kicker ("sling") 63
8 WHT-GRY 1J10-1	High Score Reset 8	16	Top Left Eject 24	Car Down 32	40	48	N 56	BR Kicker ("sling") 64

BL = Bottom Left BR = Bottom Right

WARNINGS & NOTICES

WARNING

FOR SAFETY AND RELIABILITY, WILLIAMS ELECTRONICS GAMES does not recommend or authorize any substitute parts or modifications of WILLIAMS' equipment. Use of Non-WILLIAMS' parts, or modifications of game circuitry, may adversely affect game play, or may cause injuries.

SUBSTITUTE PART OR EQUIPMENT MODIFICATIONS may void FCC Type Acceptance.

BECAUSE THIS GAME IS PROTECTED by Federal copyright, trademark, and patent laws, unauthorized game conversions may be illegal under Federal law.

THIS 'CONVERSION' PRINCIPLE ALSO APPLIES to unauthorized facsimiles of WILLIAMS' equipment, logos, designs, publications, assemblies, and games (or game features not deemed to be in the public domain), whether manufactured with WILLIAMS' components or not.

WARNING

This equipment generates, uses, and can radiate radio frequency energy, and if not installed and used in accordance with the instructions manual, may cause interference to radio communications. It has been tested and found to comply with the limits for a Class A computing device pursuant to Subpart J of Part 15 of FCC Rules, which are designed to provide reasonable protection against such interference when operated in a commercial environment. Operation of this equipment in a residential area is likely to cause interference in which case the user at his own expense will be required to take whatever measures may be required to correct the interference.

WARNING

FCC STICKER. Check the back of your **POLICE FORCE** game to verify that an FCC-certification sticker was attached to your game at the factory.

All games that leave WILLIAMS' plants have been tested and found to comply with FCC Rules. Because the sticker is proof of this fact, legal repercussions to the owner and distributor of the game may result, if the sticker is missing. If you receive any WILLIAMS game, manufactured after December 1982, that has no FCC sticker, call WILLIAMS for advice or write us a note on your Game Registration Card. Be sure that the card bears your game's serial number.

RF Interference Notice

CABLE HARNESS PLACEMENTS and ground strap routing on this game have been designed to keep RF radiation and conduction within levels accepted by the FCC Rules.

TO MAINTAIN THESE LEVELS, reposition harnesses and reconnect ground straps to their original placements, if they become disconnected during maintenance.

Notice

POLICE FORCE, Lane Change, and **MULTI-BALL** are trademarks of WILLIAMS ELECTRONICS GAMES, INC.

FOR SERVICE...

CALL your authorized
WILLIAMS' Distributor.

Williams[®] 
ELECTRONICS GAMES, INC.

3401 N. California Avenue
Chicago, IL 60618

WARNING:

**Transport this game ONLY
with hinged backbox DOWN!**