



# Plus/4

**NTSC MANUAL**

**SERVICE MANUAL**  
**MODEL PLUS 4 COMPUTER**  
**OCT. 1984      PN-314001-04**

**Commodore Business Machines, Inc.**

1200 Wilson Drive, West Chester, Pennsylvania 19380 U.S.A.

Commodore makes no expressed or implied warranties with regard to the information contained herein. The information is made available solely on an as is basis, and the entire risk as to quality and accuracy is with the user. Commodore shall not be liable for any consequential or incidental damages in connection with the use of the information contained herein. The listing of any available replacement part herein does not constitute in any case a recommendation, warranty or guaranty as to quality or suitability of such replacement part. Reproduction or use without expressed permission, of editorial or pictorial content, in any matter is prohibited.

This manual contains copyrighted and proprietary information. No part of this publication may be reproduced, stored in a retrieval system, or transmitted in any form or by any means, electronic, mechanical, photocopying, recording or otherwise, without the prior written permission of Commodore Electronics Limited.

Copyright © 1984 by Commodore Electronics Limited.  
All rights reserved.

# CONTENTS

<b>Title</b>	<b>Page</b>
SPECIFICATIONS .....	1
OVERVIEW .....	2
PRODUCT PARTS LIST .....	3
CASEWORK IDENTIFICATION .....	3
PCB LAYOUT .....	4
PCB PARTS LIST .....	5
PCB SCHEMATIC DIAGRAMS .....	7
KEYBOARD MATRIX .....	7
I.C. PINOUTS FOR UNCOMMON CHIPS .....	9
RF MODULATOR 251844 LAYOUT .....	11
251844 SCHEMATIC .....	11
RF MODULATOR 251311 LAYOUT .....	12
251311 SCHEMATIC .....	12

## **PLUS 4 PRODUCT SPECIFICATION**

### **MEMORY**

64K RAM. 60K RAM User accessible for BASIC programs.

### **ROM**

32K ROM Standard (includes operating system and BASIC interpreter) with 32K additional ROM containing the built-in productivity software.

### **MICROPROCESSOR**

7501 Microprocessor — .89 or 1.76 MHz clock.

### **DISPLAY**

40 Columns x 25 lines of text.

### **COLORS**

128 Colors (16 colors; 8 luminance levels).

### **CHARACTERS**

Upper & lower case letters, numerals and symbols. Reverse and flashing characters. All PET graphic characters.

### **DISPLAY MODES**

Text characters. High resolution graphics. Split screen text/high resolution graphics. Multicolor graphics.

### **RESOLUTION**

320 x 200 Pixels

### **SOUND**

2 Tone generators or 1 Tone and 1 white noise generator.

### **VOLUME**

8 Volume levels

### **KEYBOARD**

Full size typewriter style design

### **KEYS**

67 Keys total. 4 Cursor control keys. 4 Programmed (reprogrammable) function keys (up to 8 user defined functions possible). Color control keys. HELP key. Upper and lower case character set. Graphics character set.

### **INPUTS/OUTPUTS**

PLUS/4 MODEM (User) port. Serial port. ROM cartridge and parallel disk drive port. 2 Joystick ports. C1531 Cassette drive interface port. RF Output-channel 3 or 4. Video output-composite/chrominance/luminance. Audio input/output. Power supply input.

## **PLUS 4 PRODUCT SPECIFICATION (Continued)**

### **FEATURES**

Built-in extended BASIC 3.5 — over 75 commands. Built-in Machine Language monitor — over 12 commands. Built-in graphics and sound commands. Screen window capability. Reset button (Warm start). Built-in integrated productivity software.

### **PERIPHERALS**

C1551 Fast Disk drive, C1531 Datasette, MPS 802 Dot matrix printer, MPS 803 Dot matrix printer, DPS 1101 Daisy wheel printer, C1802 color monitor.

### **OTHER PERIPHERALS**

C1541 Disk drive, MPS 801 Dot matrix printer, C1702 color monitor.

## **PLUS 4 OVERVIEW**

The Plus 4 system is based on the 7501 microprocessor, an HMOS version of the 6510. Video processing is achieved by the 7360 TED chip. 64K bytes of dynamic RAM are accomplished by 8 (64K x 1) I.C.'s. (See page ). The system program is contained in 2 (16K x 8) ROMs. The system supports up to 128K x 8 of ROM banked in 16K sections. By software control, through the 7360, ROM can be completely banked out and RAM banked in for a true 64K of RAM (minus 256 byte pages), allowing 60,671 bytes available for BASIC.

Keyboard and joystick scanning are accomplished by outputting the row data on the data bus while addressing a particular register in the TED chip. This will in turn cause the TED chip to latch the column information.

A standard serial port supports serial bus peripherals such as the 1541 disk drive and the various serial printers. A cassette port is provided and the expansion port supports ROM cartridges. TTL serial ASCII is intended to drive an RS-232 adapter.

**PARTS LIST  
PLUS/4**

**TOP CASE ASSY**

Top Case	C 251453-01
Keyboard, 67 Key, KKR-I	C 251501-01
Nameplate	C 251655-01
Shield Clip, R	C 251855-01
Shield Clip, F	C 251856-01

**BOTTOM CASE ASSY**

Bottom Case	C 251454-01
Foot, Self-Adhesive	C 950157-04
Paper Shield	C 310156-01
Shield Chip	C 310199-01
Shield Plate	C 310197-01
Insulation Sheet	C 310198-01

**ACCESSORIES**

Users Manual	C 310196-01
Power Supply	C 310157
RF Cable	C 326189-02
Switch Box	C 904778-01

C — Commodore Stock Part

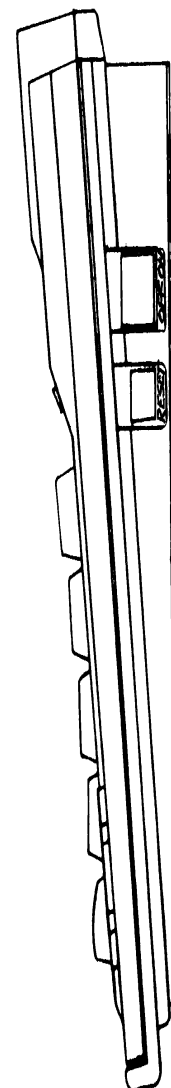
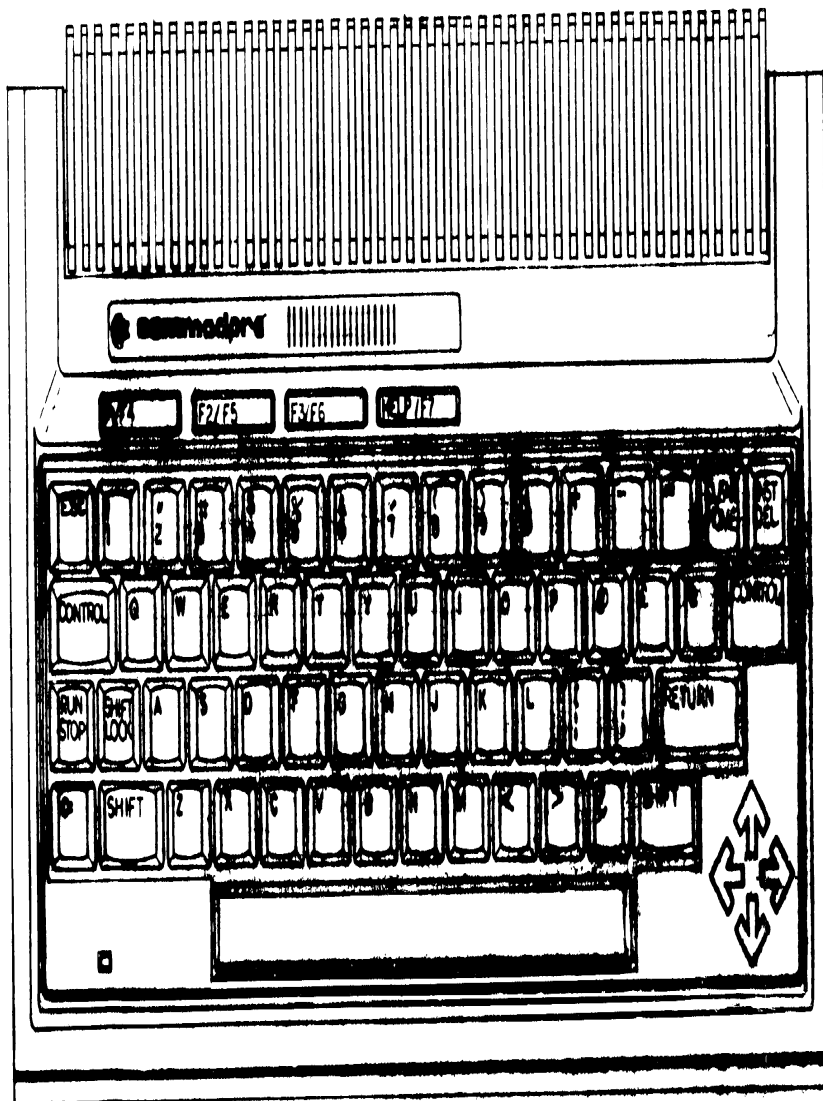
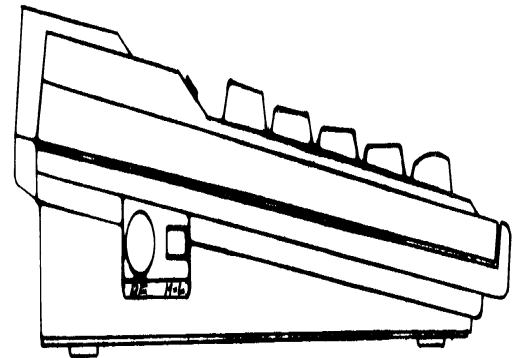
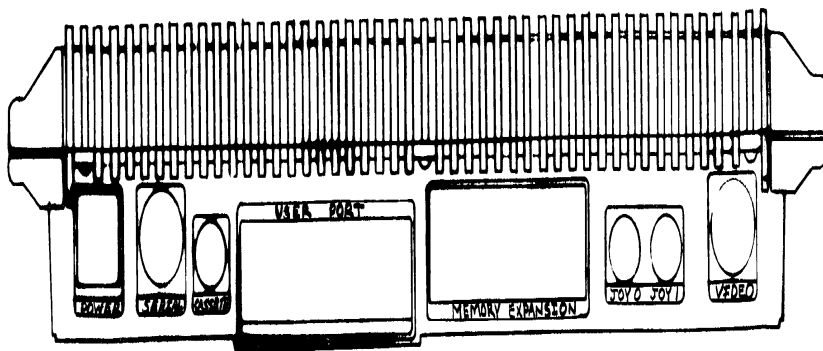

Plus 4 Casework Identification

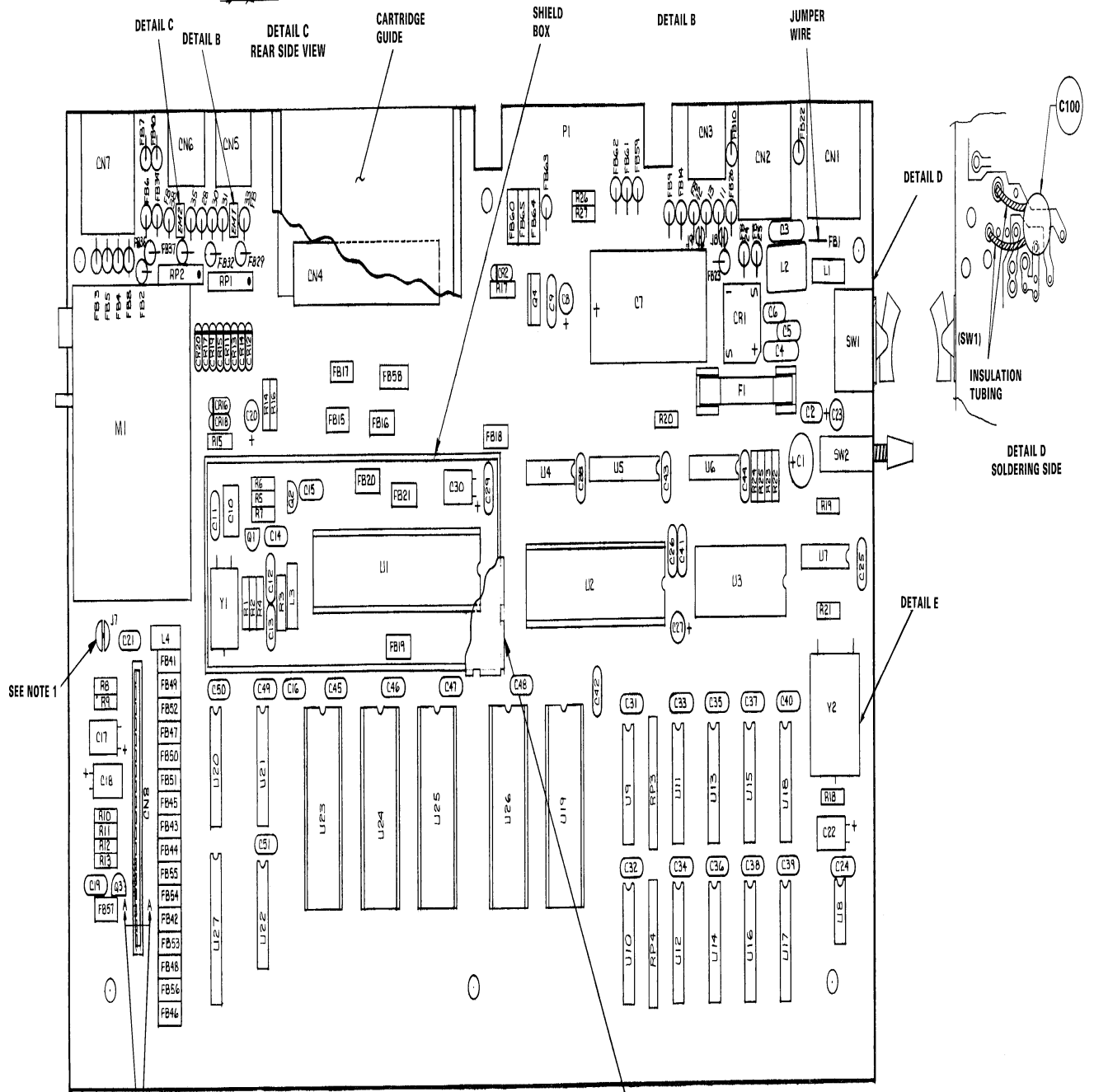
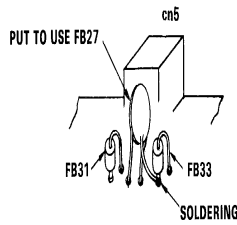
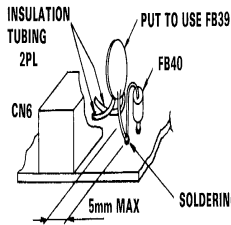

SEE NOTE 1

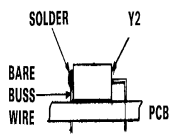
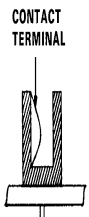
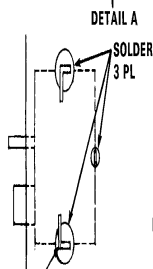

1. JUMPER SELECTION FOR "J1"  
 - DOESN'T MATTER FOR NTSC (-011).  
 - SHORT FOR G-PAL (-021).  
 - OPEN FOR I-PAL (-031).

NOTES - UNLESS OTHERWISE SPECIFIED:

Plus 4 PCB Assembly



## PARTS LIST — PLUS/4 PCB ASSEMBLY #310163-01

**PLEASE NOTE:** Commodore part numbers are provided for reference only and do not indicate the availability of parts from Commodore. Industry standard parts (Resistors, Capacitors, Connectors) should be secured locally. Approved cross-references for TTL chips, Transistors, etc. will be available in manual form through the Service Department in November of 1984. Unique or non-standard parts will be stocked by Commodore and are indicated on the parts list by a "C".

INTEGRATED CIRCUITS		DIODES (Continued)	
U1	7360 VLSI, Text Display (TED) Sub: C 251535-01 8360 C 251535-02	CR1 (cont.)	Bridge Rectifiers DBA20C Sanyo 251026-03
U2	7501 Custom Microprocessor C 251536-01	CR2	Diode, Zener RD 6.8 EB 900927-01
U3	6551A (Synertek) 901895-02	CR11-20	Diode, IN 914 Sub: 900850-16 Diode, IN 4148 Taping 251819-21 Sub:
U4	74LS08 901521-03		Diode, IN 4148 900850-01
U5	6529B Single Port Interface C 251640-03	<b>RESISTORS</b> — All values are in ohms-1/4 W 5% unless noted otherwise.	
U6	74LS04 901521-02	R1	4.7K 240
U7	7406 901522-06	R2	10K 250
U8	555 901523-01	R3	470K 100K
U9-10	74LS257 901521-57	R4	220K 1.5K
U11-18	4164-2 D-RAM 901505-01	R5	18K 47K
U19	7700-010 PLA C 251641-02	R6	1.5K 100K
U20	74LS139 901521-18	R7	470K 3K
U21	74LS175 901521-34	R8	100K 1K
U22	74LS27 901521-22	R9	1K 1K
U23	2312B ROM TED Basic C 318006-01	R10	1K 1K
U24	23128 ROM TED Kernal C 318005-04	R11	12K 1K
U25	23128 FUNCTION ROM, 3+1 LOW C 317053-01	R12	10K 1K
U26	23128 FUNCTION ROM, 3+HIGH C 317054-01	R13	1K 1K
U27	6529B Single Port Interface C 251640-03	<b>RESISTOR PACK</b>	
<b>TRANSISTORS</b>		RP1, 2	3.3K, 6 PIN 902441-29
Q1-Q3	2SC 1815 902693-01	RP3, 4	68, 8 PIN 4 ISOLATED 326149-06
Q4	2SD 880 902694-01 Sub: Tip 29A 902653-01 Sub: 2SD 1266 902694-04	<b>CAPACITORS</b>	
<b>DIODES</b>		C1	Elect 0.1 $\mu$ F 25V 900100-40
CR1	Bridge Rectifiers S2VB10 Sindengen 215026-01 Sub:	C2	Ceramic 0.1 $\mu$ F 25V 251075-06
	Bridge Rectifiers DBA20B Sanyo 251026-02 Sub:	C3	Film 0.22 $\mu$ F 100V 900150-11
		C4	Film 0.22 $\mu$ F 100V 900150-11
		C5-C6	Ceramic 0.22 $\mu$ F 50V 900022-01
		C7	Elect 2200 $\mu$ F 16V 900101-33
		C8	Elect 10 $\mu$ F 16V 900100-25
		C9	Ceramic 0.1 $\mu$ F 25V 251075-06
		C10	Trimmer 40 pF 251029-02
		C11	Ceramic 22 pF 50V 251070-14

**PARTS LIST – PLUS/4**  
**PCB ASSEMBLY # 310163-01 (Continued)**

<b>CAPACITORS (Continued)</b>				<b>MISCELLANEOUS (Continued)</b>		
C12	Ceramic	220 pF 50V	Sub: 251071-26 Sub:	FB2-14	Ferrite bead	325563-01
C13	Ceramic	220 pF 50V	900463-08	FB15-21	Ferrite bead	903025-01
	Ceramic	150 pF 50V	251071-24	FB22-26, FB28-38, FB40	Ferrite bead	325563-01
	Ceramic	150 pF 50V	900462-41	FB41-58	Ferrite bead	903025-01
C14	Ceramic	0.1 μF 25V	251075-01	FB59	Ferrite bead	325563-01
C15-C16	Ceramic	0.1 μF 25V	251075-06	FB60	Ferrite bead	903025-01
C17-C18	Ceramic	10 μF 16V	900100-25	FB61-63	Ferrite bead	325563-01
C19	Ceramic	0.01 μF 25V	251075-01	FB64-65	Ferrite bead	903025-01
C20	Elect	10 μF 16V	900100-25			
C21	Ceramic	0.1 μF 25V	251075-06	EM1,2	EMI Filter	251842-01
C22	Elect	10 μF 16V	900100-25			
C23	Elect	1 μF 16V	900100-16	CN1	Connector 4 PIN (power supply)	C 251614-01
C24-C26	Ceramic	0.1 μF 25V	251075-06	CN2	Connector 6 PIN DIN (serial bus)	C 903361-01
C27	Elect	10 μF 16V	900100-25	CN3	Connector 7 PIN MINI DIN (cassette)	C 251616-01
C28-C29	Ceramic	0.1 μF 25V	251075-06	CN4	Connector 50 PIN Female Edge (exoab)	C 251630-01
C30	Elect	10 μF 16V	900100-25	CN5-6	Connector 8 PIN MINI DIN (joy 1 & 2)	C 251259-01
C31-C32	Ceramic	0.1 μF 25V	251075-06	CN7	Connector 8 PIN DIN (audio/video)	325573-01
C33-C40	Ceramic	0.22 μF 25V	251075-07	CN8	Connector 18 PIN (keyboard)	C 251841-01
	Sub:					
C41-C51	Ceramic	0.22 μF 50V	900022-01			
	Ceramic	0.1 μF 50V	900020-06			
	Sub:					
	Ceramic	0.1 μF 50V	9000010-01			
C100	Ceramic	0.1 μF 50V	900010-20			
<b>MISCELLANEOUS</b>						
Y1	Crystal	14.31818 MHZ	251081-01	L1	Noise Filter	251264-01
	Sub:			L2	Line Filter	906127-01
	Crystal	14.31818 MHZ	251081-02		Sub:	251701-01
Y2	Crystal	1.8432 MHZ	900555-02		Sub:	
				L3,L3	Coil Inductor 1.2 uHpt	901152-01
					Sub:	325570-01
SW1	Switch, Rocker (PC Mount)		C 251587-01	F1	Fuse 250V 1.5A	903556-18
SW2	Switch, Push Button		C 251260-01		Fuse Clip	906102-01
M1	RF Modulator		C 251844-01		Cartridge Guide	310171-01
	Sub:				Shield Box	C 310172-01
	RF Modulator		251311-01		Shield Cap	C 310173-01

C – Commodore Stock Part

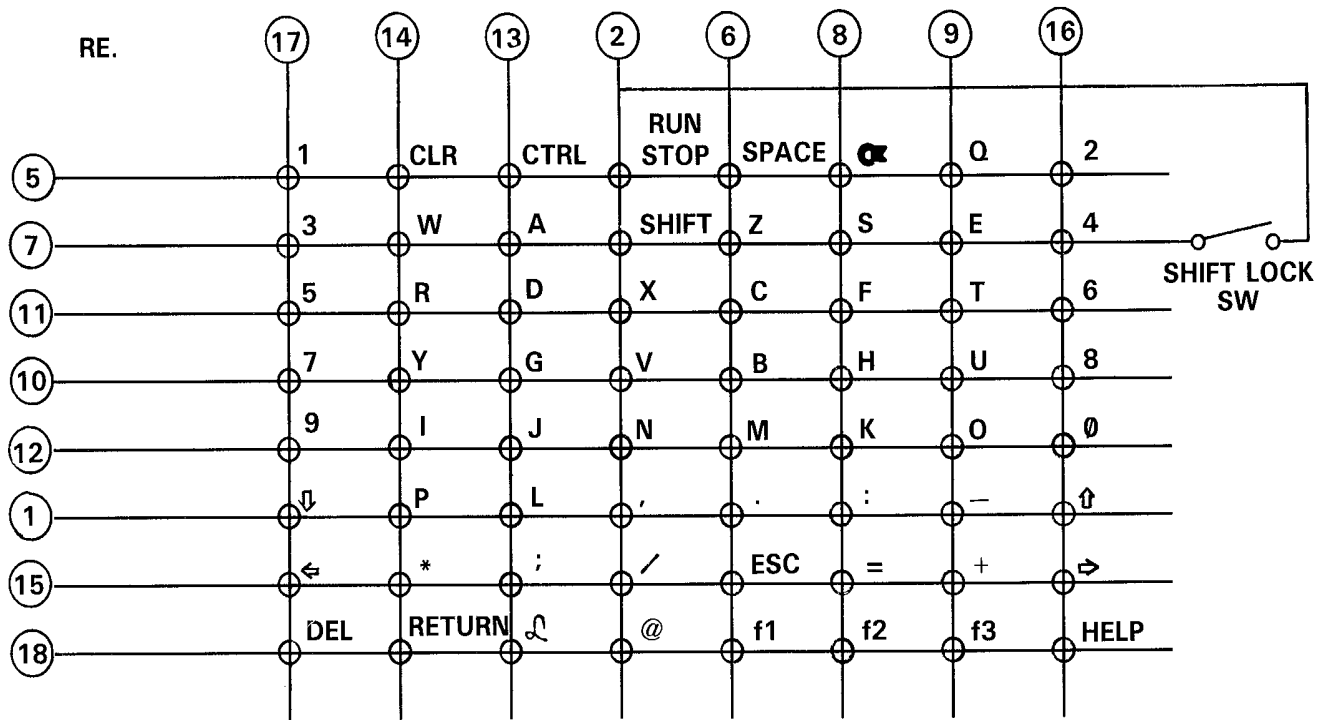

KEYBOARD MATRIX

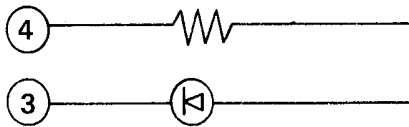

$\phi$ OIN	1	40	RES
RDY	2	39	R/W
$\overline{\text{IRQ}}$	3	38	D0
AEC	4	37	D1
VCC	5	36	D2
A0	6	35	D3
A1	7	34	D4
A2	8	33	D5
A3	9	32	D6
A4	10	31	D7
A5	11	30	P0
A6	12	29	P1
A7	13	28	P2
A8	14	27	P3
A9	15	26	P4
A10	16	25	P5
A11	17	24	P6
A12	18	23	GATE IN
A13	19	22	A15
GND	20	21	A14

**PIN ASSIGNMENT**  
**U2-251536-01**  
**CUSTOM MICROPROCESSOR**

A2	1	48	A3
A1	2	47	A4
A0	3	46	A5
VDD	4	45	A6
$\overline{\text{CS0}}$	5	44	A7
$\overline{\text{CS1}}$	6	43	A8
R/W	7	42	A9
$\overline{\text{IRQ}}$	8	41	A10
MUX	9	40	A11
$\overline{\text{RAS}}$	10	39	A12
$\overline{\text{CAS}}$	11	38	A13
$\phi$ 0	12	37	A14
COLOR	13	36	A15
CLK IN	14	35	AEC
K0	15	34	BA
K1	16	33	SND
K2	17	32	D7
K3	18	31	D6
K4	19	30	D5
K5	20	29	D4
K6	21	28	D3
K7	22	27	D2
SYNC	23	26	D1
VSS	24	25	D0

**PIN ASSIGNMENT**  
**U1-251535-01**  
**VLSI, TEXT DISPLAY**  
**(TED)**

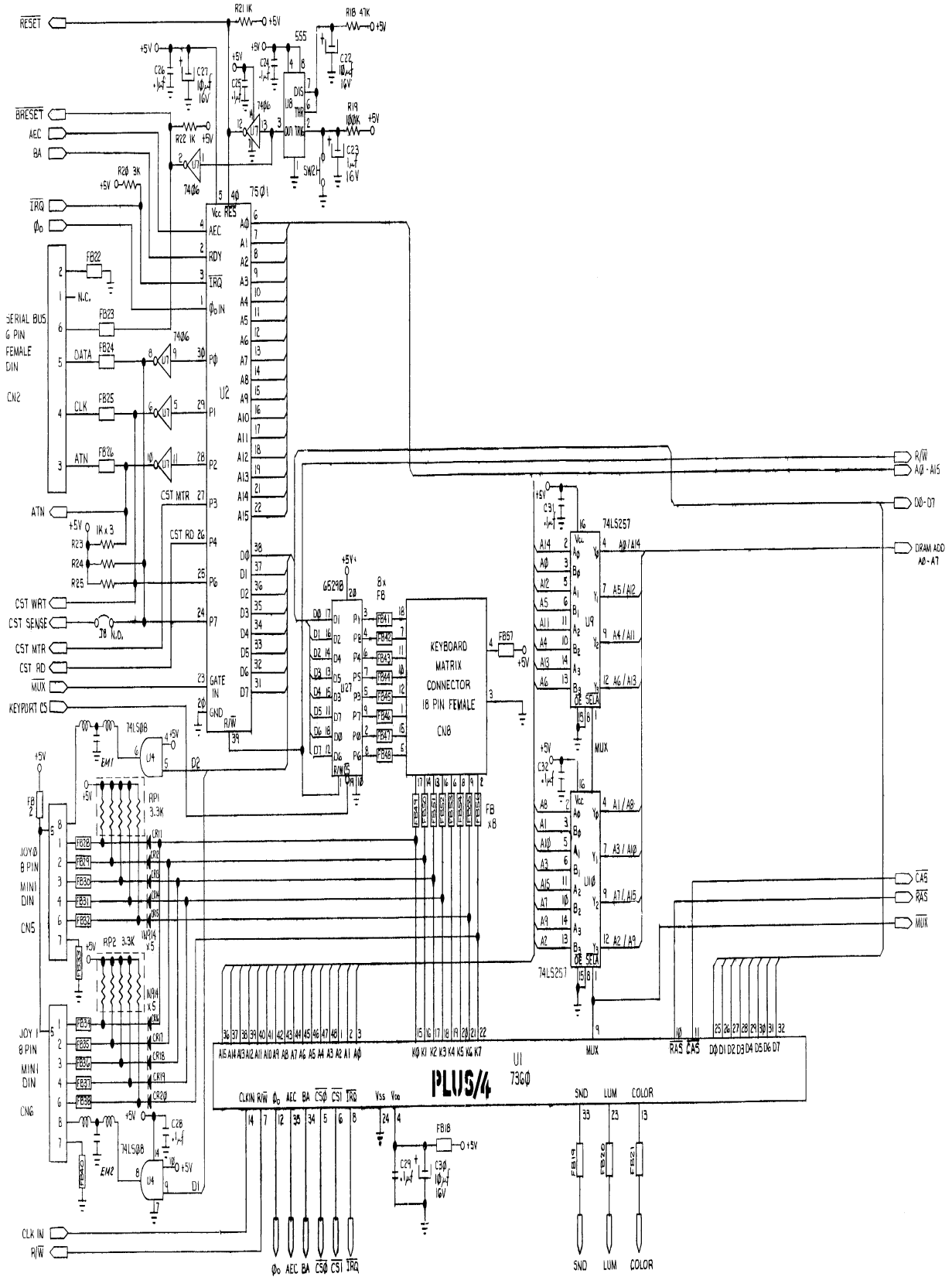

Plus 4 Schematic #310164 (1 of 4)

**M<sub>1</sub> SCHEMATIC ON PAGE 11**

**PIN CONFIGURATION**

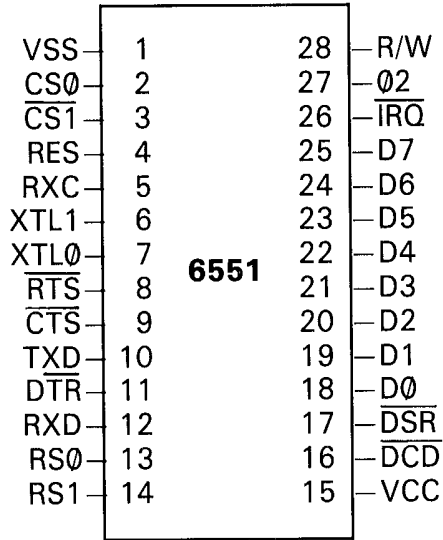

**U3-901895-02  
ACIA**

<b>SYNERTEK</b>	<b>SYP6551A</b>	<b>2 MHZ</b>
-----------------	-----------------	--------------

**TRANSMIT/RECEIVE CHARACTERISTICS**

CHARACTERISTICS	SYM	-02 2 MHZ		UNIT
		MIN	MAX	
TRANSMIT/RECEIVE CLOCK RATE	t <sub>CCY</sub>	*	—	ns
TRANSMIT/RECEIVE CLOCK HIGH TIME	t <sub>CH</sub>	175	—	ns
TRANSMIT/RECEIVE CLOCK LOW TIME	t <sub>CL</sub>	175	—	ns
XTL1 TO TXD PROPAGATION DELAY	t <sub>DD</sub>	—	500	ns
RTS PROPAGATION DELAY	t <sub>DLY</sub>	—	500	ns
IRQ PROPAGATION DELAY (CLEAR)	t <sub>IRQ</sub>	—	500	ns

(tr, tf = 10 to 30 ns)

\* The Baud Rate with External Clocking is:

$$\text{BAUD RATE} = \frac{1}{16 \times T_{CCY}}$$

**PIN CONFIGURATION**

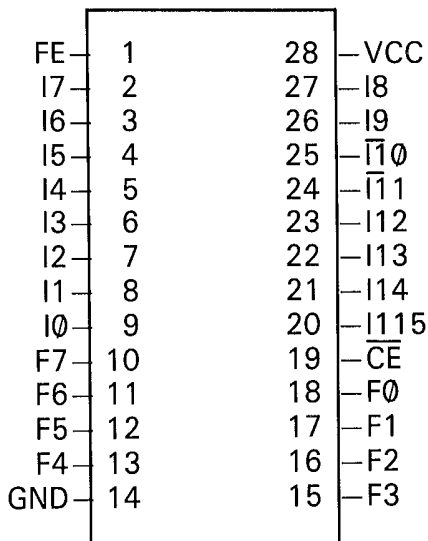

**U19-251641-02  
PLA**

**PIN CONFIGURATION**

CS	R/W	D0-D7
L	L	DATA BUS TO PORT
L	H	PORT TO DATA BUS
H	X	ISOLATION

L = LOW LEVEL  
H = HIGH LEVEL  
X = IRRELEVANT

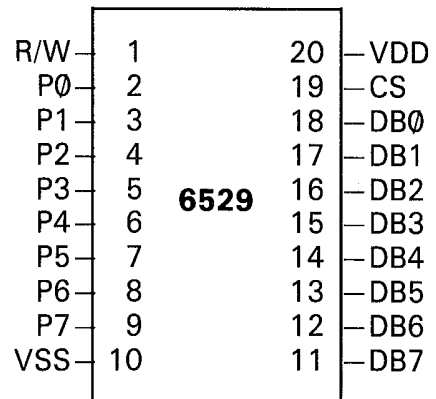

<b>MOS</b>	<b>6529B</b>	<b>3 MHz</b>
------------	--------------	--------------

**U5/U27-251640-03  
SINGLE PORT  
INTERFACE**

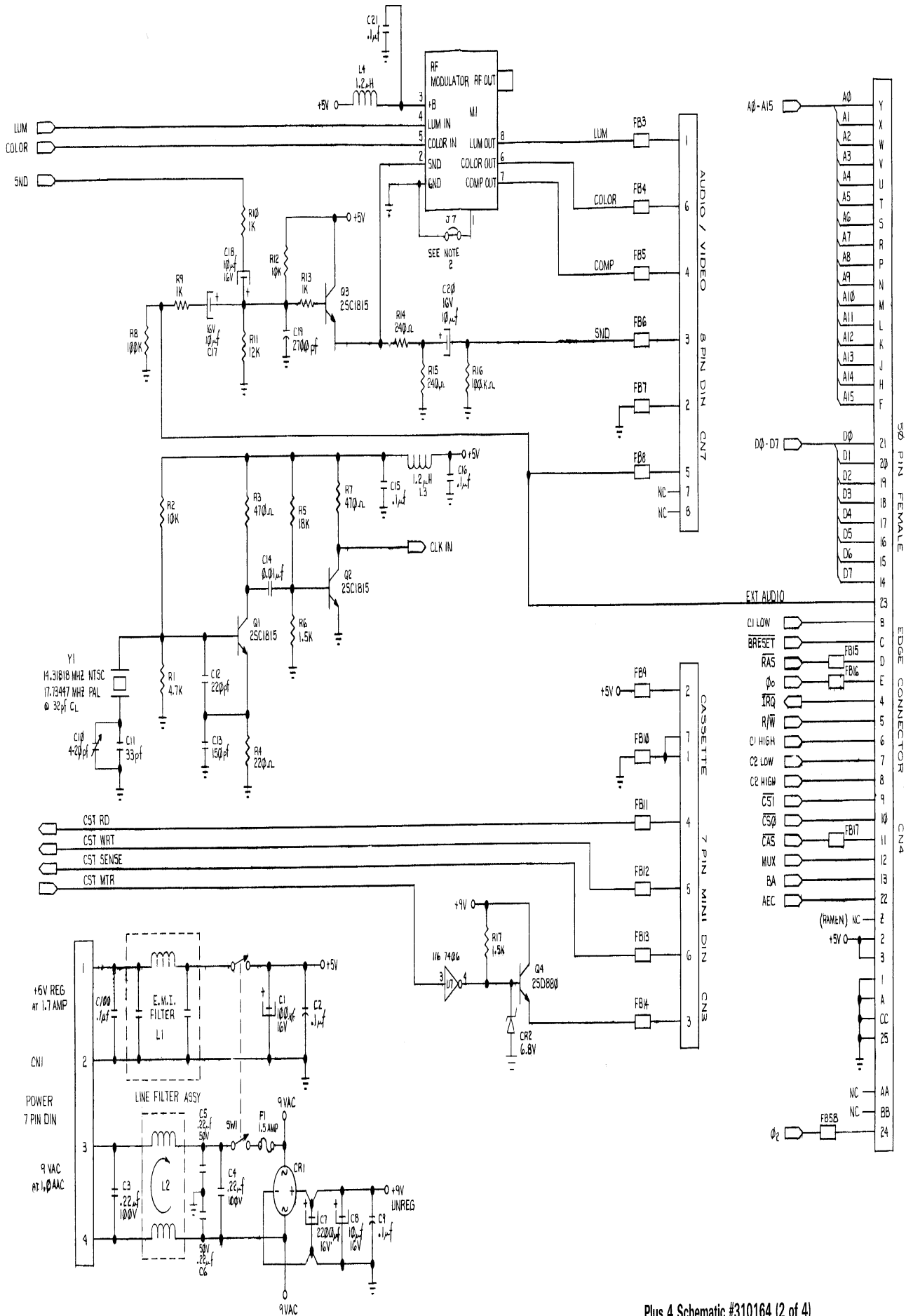

Plus 4 Schematic #310164 (2 of 4)

**U3, U5, U19 PINOUTS ON PAGE 8**

**PIN CONFIGURATION**

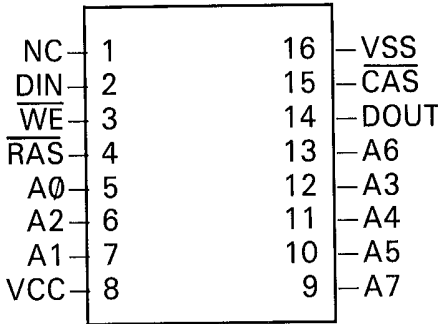

**U11 ~ 18  
64K DYNAMIC RAM  
901505-01**

COMMODORE PART NUMBER	APPROVED SOURCE 1 OF SUPPLY	VENDOR PART NUMBER	ACCESS TIME (ns)	CYCLES (ns)	POWER	
					ACTIVE (MW)	STANDBY (MAX)(MW)
901505-01	HITACHI	HM4864-3	200	335	330	20
901505-01	NEC	$\mu$ PD4164-2	200	375	250	28
901505-01	MITSUBISHI	M5K416NS-20	200	330	275	28
901505-01	MOSTEK	MK4564N-20	200	345	300	22
901505-01	OKI	MSM3764-20	200	330	248	23
901505-01	HITACHI	HM4864P-3	200	335	330	20
901505-01	MATSUSHITA (PANASONIC)	MN4164P-20	200	330	275	27.5
901505-01	SIEMENS	HYB4164-3	200	330	150	20
901505-01	SHARP	LH2164-Z1	200	330	248	28
901505-01	HITACHI	HM4864AP-3	200	330	242	20
901505-01	TOSHIBA	TMM4164AP-20	200	330	275	22

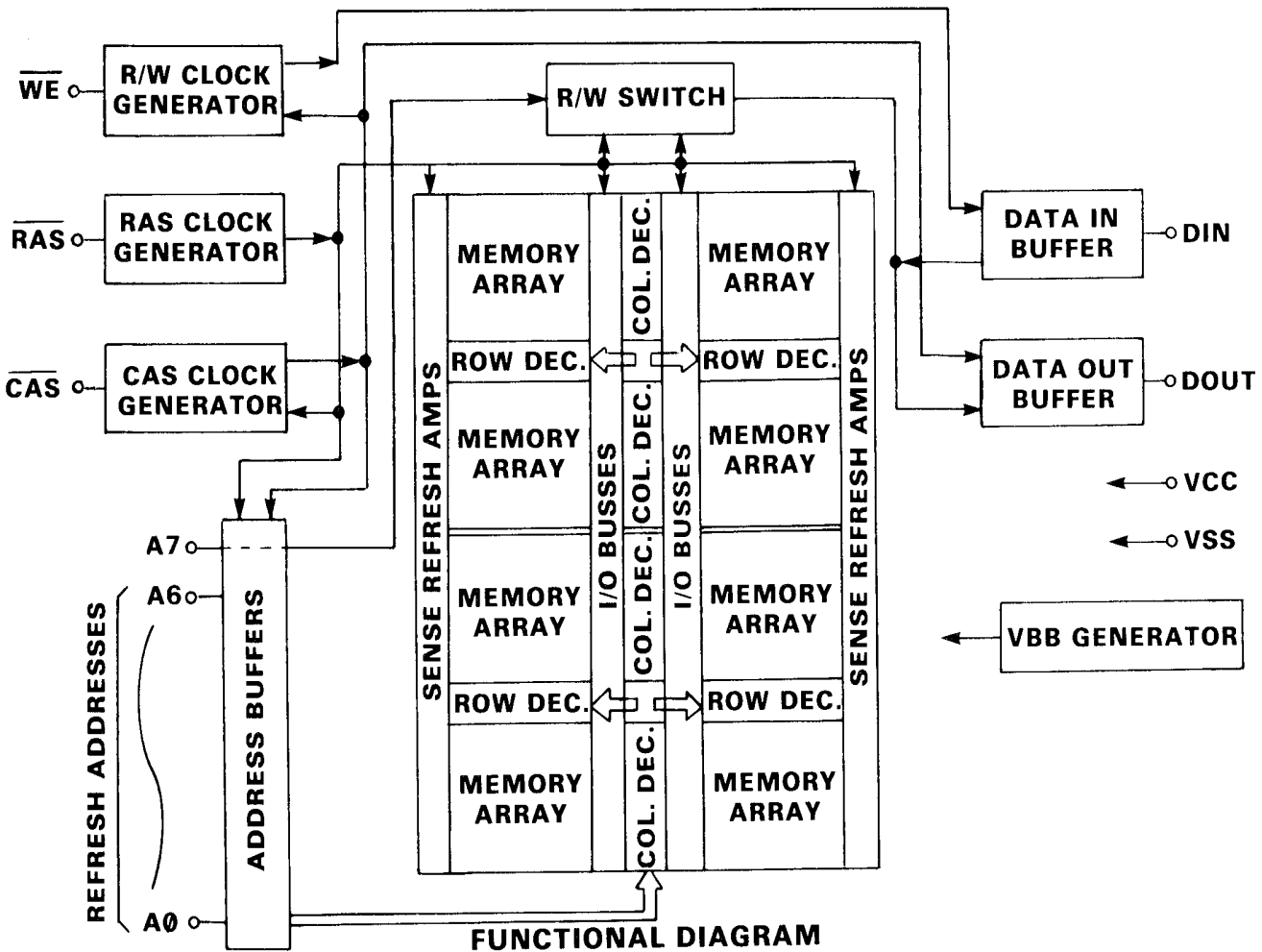

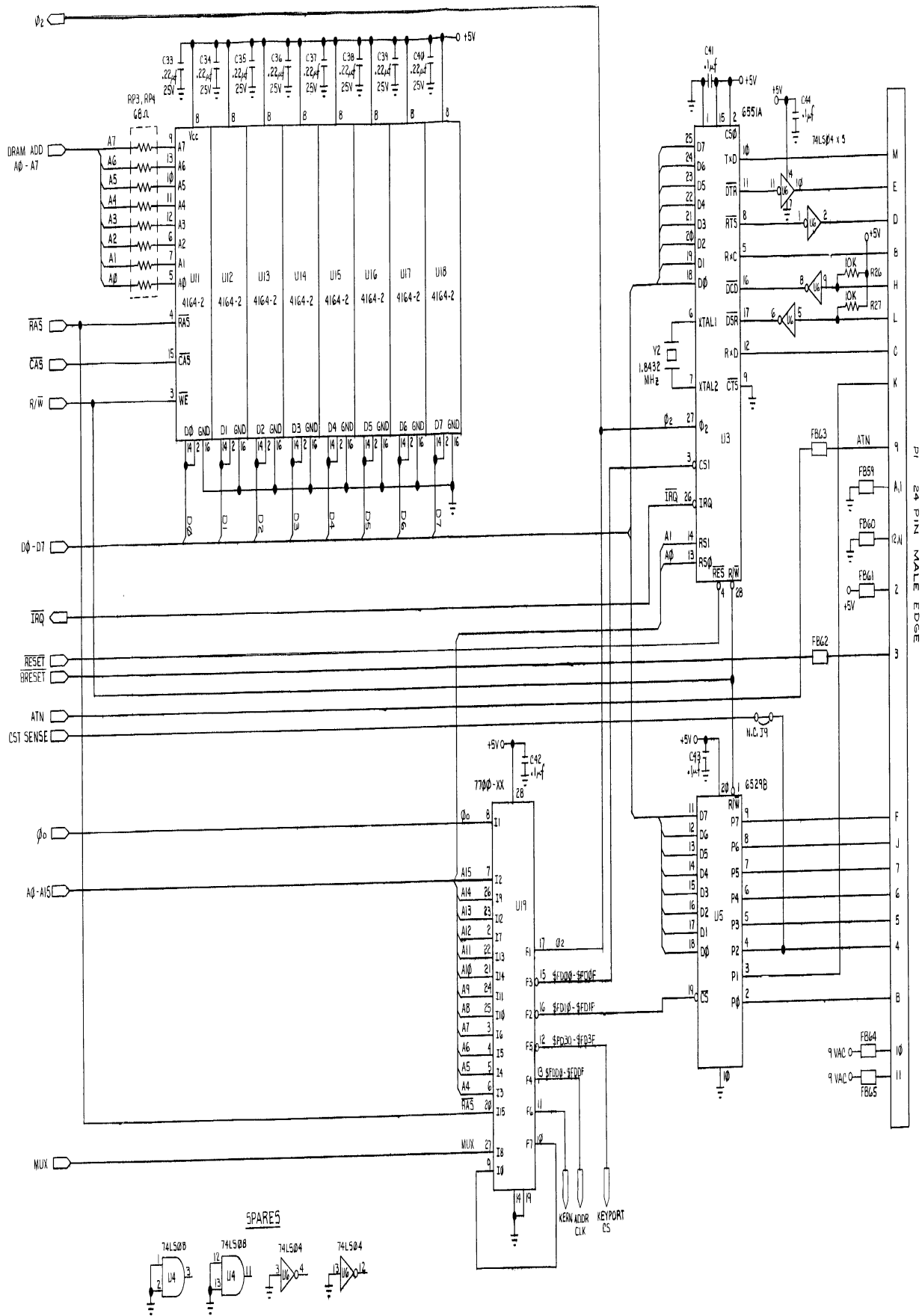

Plus 4 Schematic #310164 (3 of 4)



**PIN  
CONFIGURATION**

NC	1	28	VCC
A12	2	27	CS <sub>3</sub>
A7	3	26	A13
A6	4	25	A8
A5	5	24	A9
A4	6	23	A11
A3	7	22	$\overline{\text{CS}}_1$
A2	8	21	$\overline{\text{A10}}$
A1	9	20	$\overline{\text{CS}}_2$
A0	10	19	D8
D1	11	18	D7
D2	12	17	D6
D3	13	16	D5
GND	14	15	D4

**U23-318006-01  
ROM – BASIC**

**PIN  
CONFIGURATION**

NC	1	28	VCC
A12	2	27	CS <sub>3</sub>
A7	3	26	A13
A6	4	25	A8
A5	5	24	A9
A4	6	23	A11
A3	7	22	$\overline{\text{CS}}_1$
A2	8	21	$\overline{\text{A10}}$
A1	9	20	$\overline{\text{CS}}_2$
A0	10	19	D8
D1	11	18	D7
D2	12	17	D6
D3	13	16	D5
GND	14	15	D4

**U24-318005-04  
ROM – KERNAL**

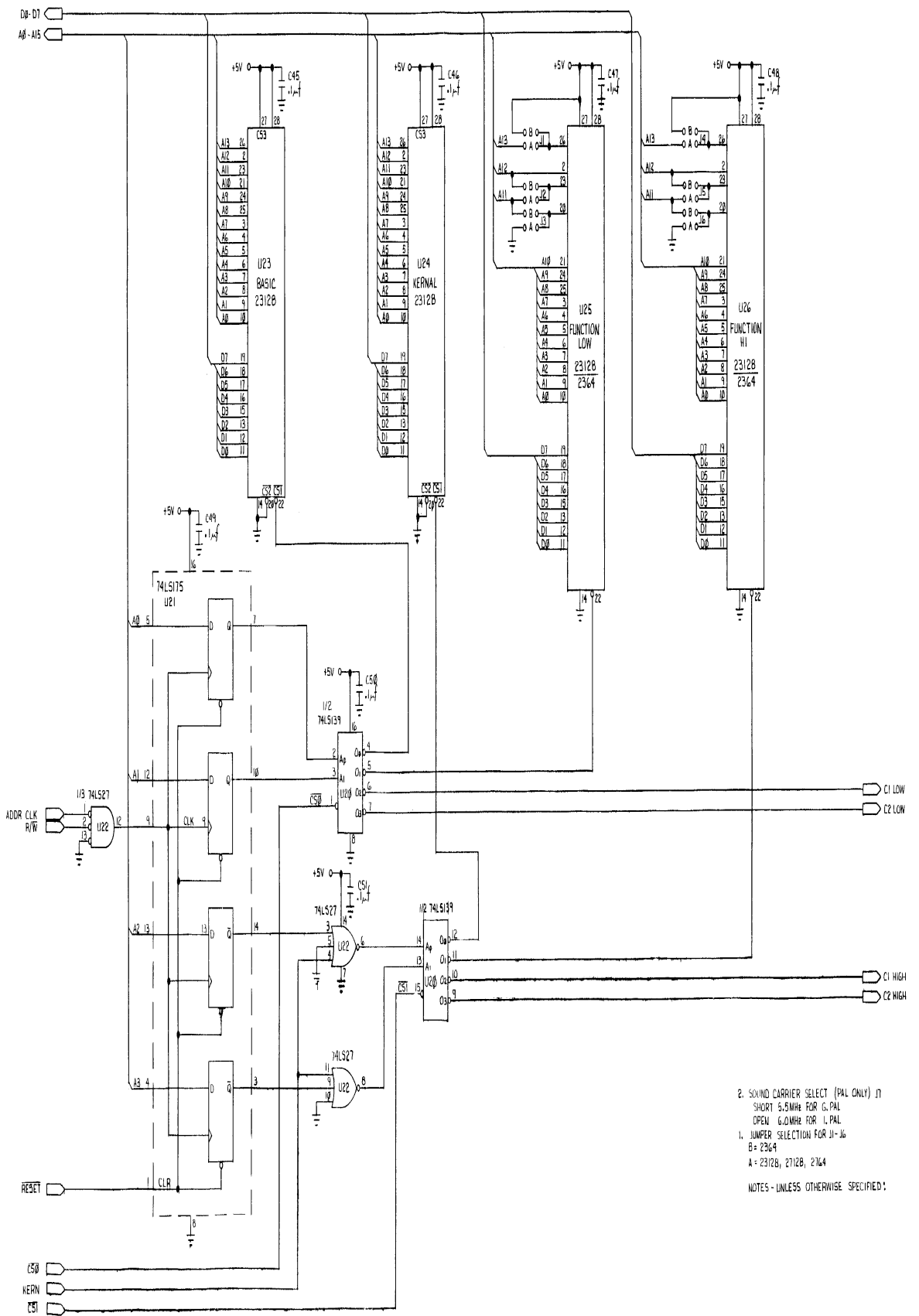

Plus 4 Schematic #310164 (4 of 4)

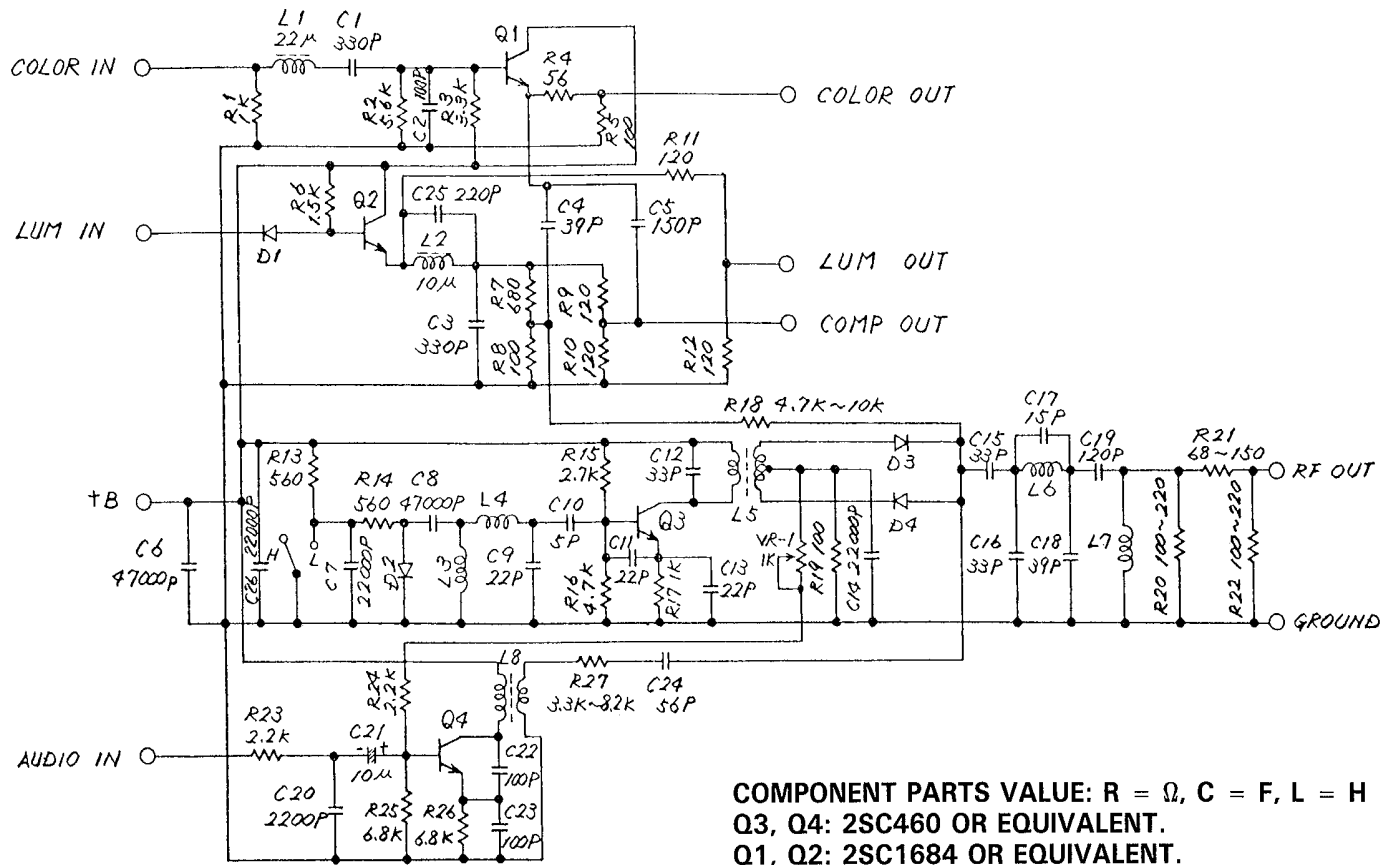

COMPONENT PARTS VALUE: R =  $\Omega$ , C = F, L = H  
 Q3, Q4: 2SC460 OR EQUIVALENT.  
 Q1, Q2: 2SC1684 OR EQUIVALENT.  
 D3, D4: 1SS198 OR EQUIVALENT.  
 D2 : 1SS110 OR EQUIVALENT.  
 D1 : 1SS119 OR EQUIVALENT.

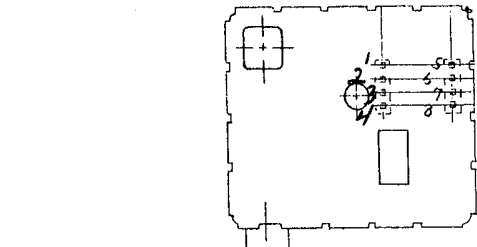

TOP VIEW

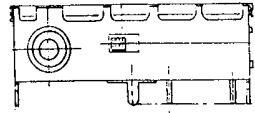
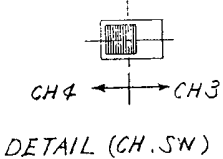

REAR VIEW

NO.	TERMINALS
1	N.C.
2	AUDIO SIG. INPUT
3	+B (+5V)
4	SYNC + LUM. SIG. INPUT
5	COLOR SIG. INPUT
6	COLOR SIG. OUTPUT
7	COMPO. SIG. OUTPUT
8	SYNC + LUM. SIG. OUTPUT
9	RF OUTPUT
10	CHANNEL SELECT SW.

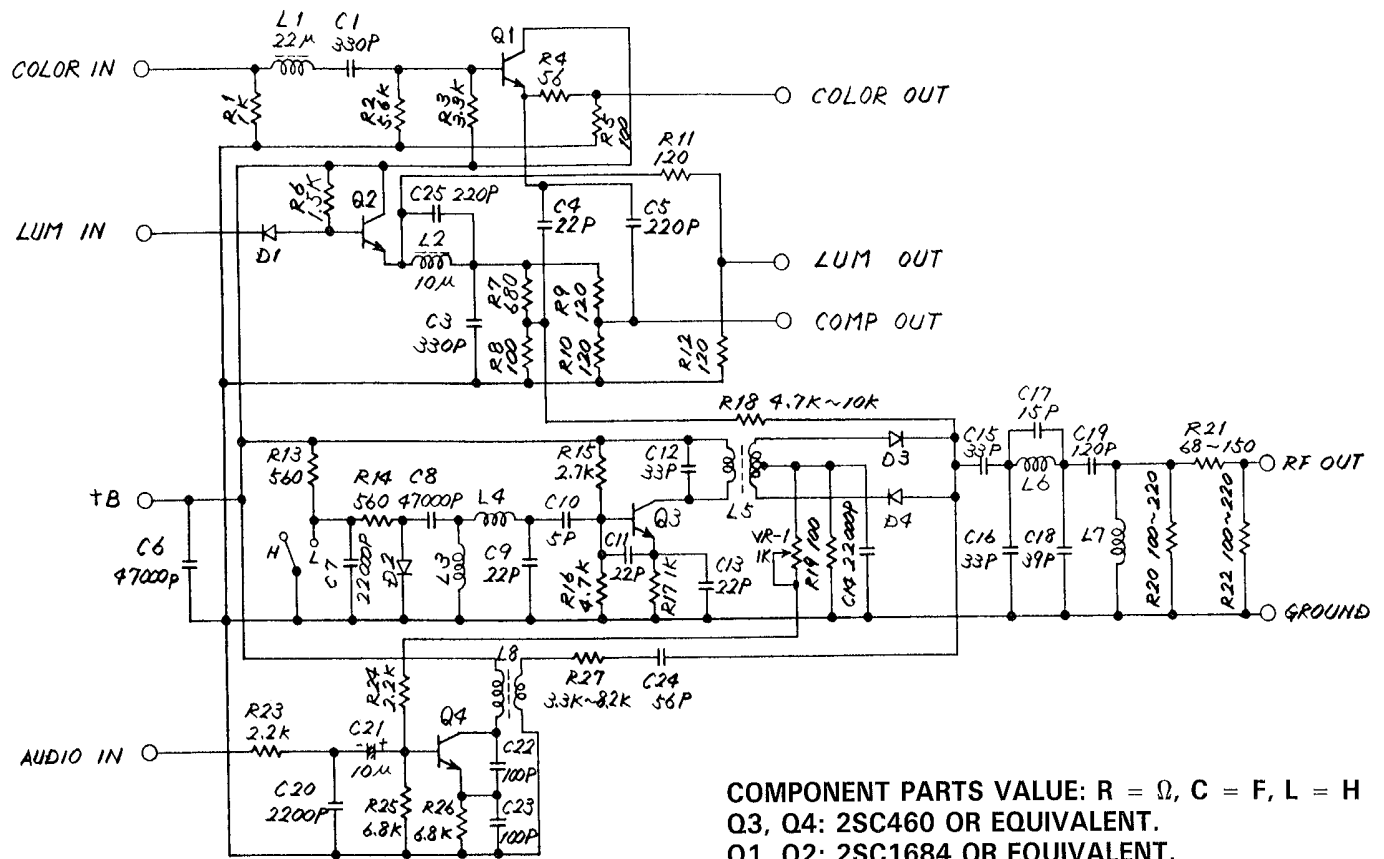

COMPONENT PARTS VALUE: R =  $\Omega$ , C = F, L = H  
 Q3, Q4: 2SC460 OR EQUIVALENT.  
 Q1, Q2: 2SC1684 OR EQUIVALENT.  
 D3, D4: 1SS198 OR EQUIVALENT.  
 D2 : 1SS110 OR EQUIVALENT.  
 D1 : 1SS119 OR EQUIVALENT.

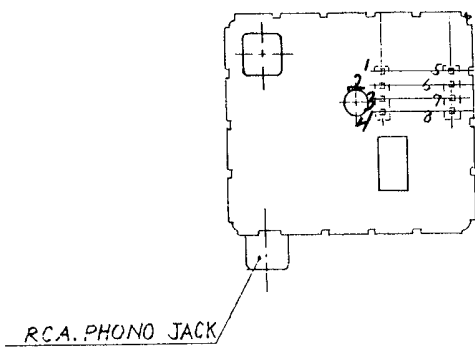

TOP VIEW

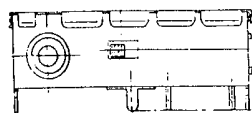
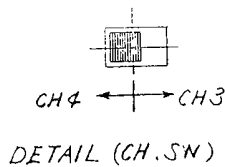

REAR VIEW

NO.	TERMINALS
1	N.C.
2	AUDIO SIG. INPUT
3	+B (+5V)
4	SYNC + LUM. SIG. INPUT
5	COLOR SIG. INPUT
6	COLOR SIG. OUTPUT
7	COMPO. SIG. OUTPUT
8	SYNC + LUM. SIG. OUTPUT
9	RF OUTPUT
10	CHANNEL SELECT SW.

Troubleshooting Aides

**NOTE: Visual inspection is critical in this unit!**  
The upright position of many of the components used on the board can create problems. It is possible for them to be shorted to the shield or to each other. Make sure they are evenly spaced and do not contact the shield.

Areas of the PCB particularly vulnerable to this problem are:

- Bottom right corner - caps
- Bottom center - J1-J6
- Bottom left - Q3 shorted to FB57
- Top left - ferrite beads
- Center - Twisted caps (just outside of RF can)

1) NO VIDEO - Absolutely no video on screen

- A) Check for 5 volts  
O.K. If not: 1) Check fuse  
2) Check for twisted or bent caps  
( 5 V. short to ground )  
↓  
3) Check L1
- B) Check for oscillation at pin 14 of U1  
O.K. If not: 1) Check for good connection at  
pin 14 of U1  
↓  
2) Check for good connection at  
R1 thru R7
- C) Check for LUM signal at pin 23 of U1, at pin 4 of  
the modulator, at pin 8 of the modulator, at FB3  
and at pin 1 of CN7  
O.K. If not: 1) Check for LUM signal shorted  
to ground  
↓  
2) Check for open traces  
3) Check modulator
- D) Check for reset  
O.K.  
↓
- E) Check for control signals:

Signal	I.C.	Pin	Signal	I.C.	Pin
AEC	U1	35	R/W	U1	7
AEC	U2	4	0	U1	12
CAS	U1	11	MUX	U1	9
CS1	U1	6	IRQ	U1	8
CS1	U20	15	RDY	U2	2
CS0	U1	5	BA	U1	34
CS0	U20	1	RAS	U1	10

2) BAD VIDEO - Scrolling lines on screen - Random blocks on screen - Blurred display

- A) Check J1-J6 for shorts to ground or each other  
O.K.  
↓
- B) Check reset for correct operation  
O.K.  
↓
- C) Check U1 for proper operation  
O.K. If not: 1) Check socket for good solder  
↓ 2) Check for bad U1
- D) Check U2 for proper operation  
O.K. If not: 1) Check socket  
↓ 2) Check for bad U2
- E) Check RAM data lines for correct amplitude  
O.K. If not: 1) Check for hot surface of RAM  
↓ 2) Jump out RAM to verify
- F) Check multiplexers U9, U10 - signals at RP3  
and RP4 should be similar in frequency and  
amplitude  
O.K. If not: 1) Suspect U9 or U10  
↓
- G) Check ROM for chip select signal at pin 22 of  
U23 and U24  
O.K. If not: 1) Check for signal generation  
↓ at U20
- H) Check that all ROM addresses are present and  
correct amplitude  
O.K. If not: 1) Trace problem address A0-A15  
↓
- I) Check U19, U23, U24 by replacement with known  
good

3) NO POWER

- A) Verify voltage +5 and +9 volts
  - 1) Check for shorts to ground
  - 2) Check switch
  - 3) Check power supply

4) BAD BASIC - Random characters on screen - Random colors - Power-up message is missing

- A) Check Basic ROM U23
- B) Check B thru I above (Bad Video)

## 5) NO COLOR or BAD COLOR

- A) Check U1 pin 14 for 14.31818 MHz with frequency counter  
O.K. If not: 1) Check solder joints of CT1 and adjust for correct frequency  
↓  
2) Check crystal, Q1 and Q2  
3) Check clock circuit for opens or shorts
- B) Check U1 pin 13 for Color Out signal.  
O.K. If not: 1) Swap U1 w/known good  
↓
- C) Check modulator M1 pin 5 for Color In signal and pin 6 for Color Out signal  
O.K. If not: 1) Check M1 operation  
↓
- D) Check FB4 and CN7 pin 6 to see if color signal is present.  
1) Check for shorts

## 6) NO SOUND or BAD SOUND

- A) Check U1 pin 33 for SND signal  
O.K. If not: 1) Check socket for open circuit  
↓  
2) Swap U1 w/known good
- B) Check audio circuit for short to ground or loss of signal.  
O.K. If not: 1) Check Q3 - Be sure emitter and base are not shorted to 5 V.  
↓
- C) Check modulator M1 pin 2 for SND signal  
1) Adjust I.F. can (top right of modulator) for clean, loud volume  
2) M1 pin 2 to ground should read approximately 480 ohms  
3) Check M1 for component failure

## 7) SERIAL FAILURES

- A) Check FB23-26 for shorts to shield or each other  
B) Check U7, U2 and CN2

## 8) KEYBOARD FAILURES

A) Check pins on ribbon cable for good connection

O.K.



B) Check for shorts - CN5, CN6, FB's, Diodes

O.K.



C) Check chip select to U27 and the I.C. U27

O.K.



D) Check U1 for proper operation

O.K. If not: 1) Check socket



2) Check for bad U1

9) FAILURES IN SOFTWARE MODE - All units should be checked for proper operation, when any repairs are necessary.

To Check: 1) Press 'F1' on keyboard

2) Press 'Return' to enter Word Processing mode

3) Press 'Commodore' key and 'C' key at the same time

4) Type 'tc' and press 'Return' to enter Spreadsheet

5) Press 'Commodore' key and 'C' key again

6) Type 'tw' to return to Word Processing mode

Watch for video or loading problems, then:

A) Check jumpers at J1-J6 for correct connection

O.K.



B) Check U1, U2, U25, U26



Model: C16, PLUS 4

LINE DEFINITIONS

A0 to A15	Address Bit 0 to 15
AEC	Address Enable Control
ATN	Attention
BA	Bus Available
BRESET	Buffered System Reset
C1 HIGH, C1 LOW	External Cartridge Chip Select
C2 HIGH, C2 LOW	"
CAS	Dynamic RAM Column Address Strobe
CLK IN	Master Clock (Single Phase, 14.31818 MHz)
COLOR	Chroma Output
COMP	Composite Chroma and Luma
CE	Chip Enable
CS	Chip Select
CS0	Low ROM Chip Select
CS1	High ROM Chip Select
CST MTR	Cassette Motor Control
CST RD	Cassette Read
CST SENSE	Cassette Sensor
CST WRT	Cassette Write
CTS	Clear To Send
DB0 to DB7	Data Bit 0 to 7
DCD	Data Carrier Detect
DRAM	Dynamic RAM
DRAM ADD	Dynamic RAM Address
DSR	Data Set Ready
DTR	Data Terminal Ready
EXT AUDIO	External Audio Input
GATE IN	R/W GATE
IRQ	Interrupt Request
K0 to K7	Keyboard Latch 0 to 7
KERN	Kernal ROM Control Line
LUM	Composite Sync and Luminance
MUX	Address Multiplex Control
P0 to P7	Port Bit 0 to 7
RAS	Dynamic RAM Row Address Strobe
RESET	System Reset
RxC	Receive Clock
RxD	Receive Data
R/W	Read/Write Line
RTS	Request To Send
SND	Sound Line
TED	Text Display
TxD	Transmit Data
φ 0	System Clock (Varies between 1 and 2 MHz)
φ 2	Artificial φ 2, Address Valid Rising Edge, Data Valid Falling Edge

SCHEMATICS FOR C-64, C-16, PLUS 4

These computers have been affected by an Engineering Change Order that adds 4 diodes to the serial port. These protection diodes are not required as field upgrades. They are 1N914s and were added as a circuit improvement.

The Schematic and PCB Layout for the C-64 in the Service Manual (Pages 28 and 32) include these diodes. However, the C-16 and Plus 4 Service Manuals were completed before the changes were made. The Schematic corrections are shown below:

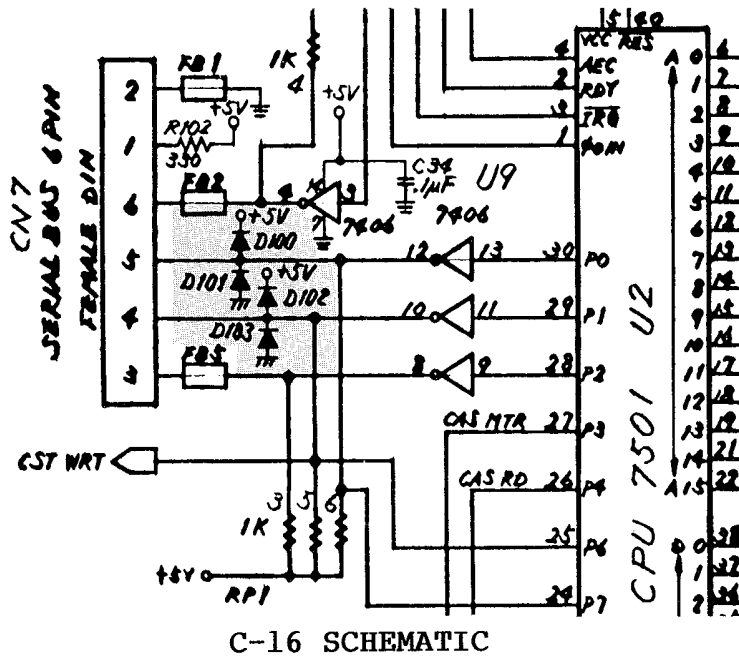

C-16 SCHEMATIC

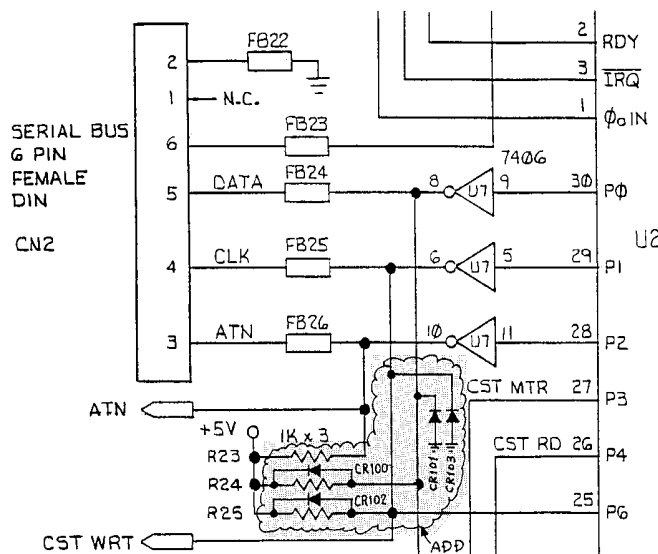

PLUS 4 SCHEMATIC