



# DEVIL'S DARE

## Instruction Manual

**Gottlieb**  
AMUSEMENT GAMES

165 W. Lake Street - Northlake, IL 60164  
(312) 562-7400 Telex 72-8463

A Columbia Pictures Industries Company 

**FINAL EDITION**  
**APPLICABLE TO ALL GAMES**  
**NOT HAVING THE LETTER "S"**  
**IN THEIR SERIAL NUMBER**

**DEVIL'S DARE (GAME 670)**  
**INSTRUCTION MANUAL**

<b>SEC.</b>	<b>TABLE OF CONTENTS</b>	<b>PAGE</b>
I.	INSTALLATION .....	1
II.	INITIALIZATION .....	4
III.	GAME OPERATION .....	4
IV.	GAME PLAY AND SCORING .....	6
V.	SOUND SPEECH BOARD (A6) .....	7
VI.	GAME ADJUSTMENTS .....	8
VII.	BOOKKEEPING AND SELF TEST .....	10
VIII.	OPTIONS .....	16
IX.	GENERAL INFORMATION .....	16
X.	WIRING AND SCHEMATIC DIAGRAMS .....	19
XI.	PARTS INFORMATION .....	49

**DEVIL'S DARE PROMS**  
**GAME PROM 670**  
**SOUND PROMS 670/S1, 670/S2**  
**CONTROL BOARD ROMS:**  
**U2, Part No. XO-326**  
**U3, Part No. XO-327**

## **SYSTEM 80A**

Devil's Dare introduces Gottlieb's enhanced System 80 Program, System 80A, which will permanently replace System 80 in future games.

System 80A has improved bookkeeping and self test capabilities, permits the use of seven digit displays and allows for greater coin/credit combination flexibility. The control boards' ROM memory chips, U2 and U3, have been reprogrammed for System 80A. They have also been socketed. In doing so, the control board can be used for either system by simply using the appropriate set of ROM memory chips.

The part numbers of each set are as follows:

<b>SYSTEM</b>	<b>U2 PART NO.</b>	<b>U3 PART NO.</b>	<b>SOCKET PART NO.</b>
<b>80</b>	<b>XO-362</b>	<b>XO-363</b>	<b>XO-529</b>
<b>80A</b>	<b>XO-326</b>	<b>XO-327</b>	<b>XO-529</b>

The ROMS are labeled as follows:

<b>SYSTEM</b>	<b>U2</b>	<b>U3</b>
<b>80</b>	<b>R3273-12</b>	<b>R3272-12</b>
<b>80A</b>	<b>XO-326</b>	<b>XO-327</b>

# I. INSTALLATION

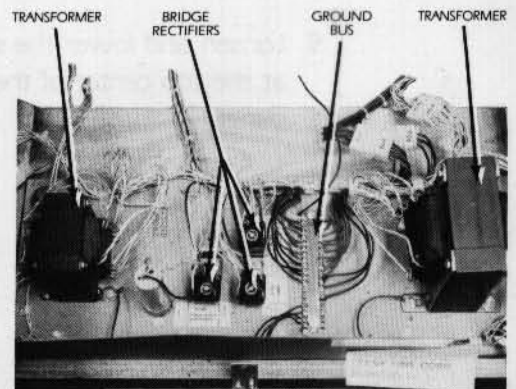
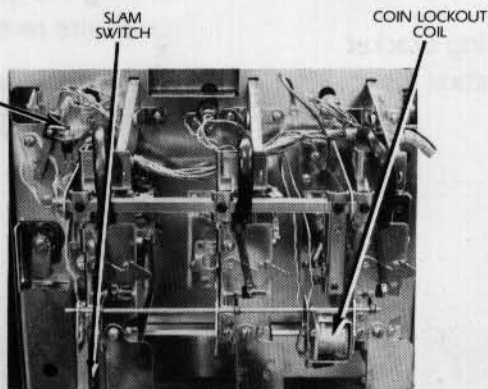
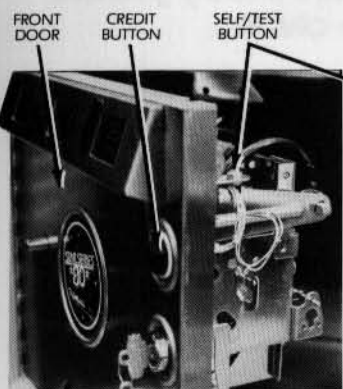
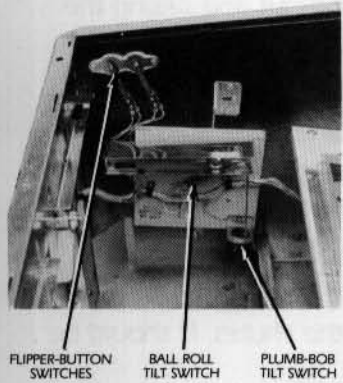
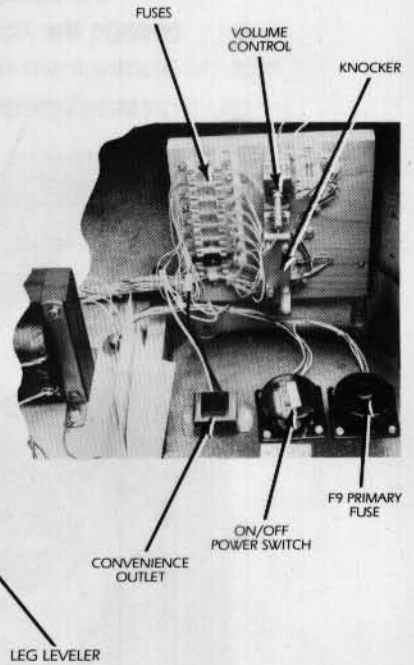
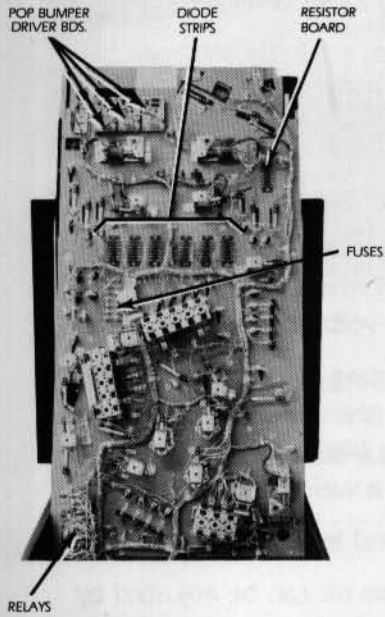
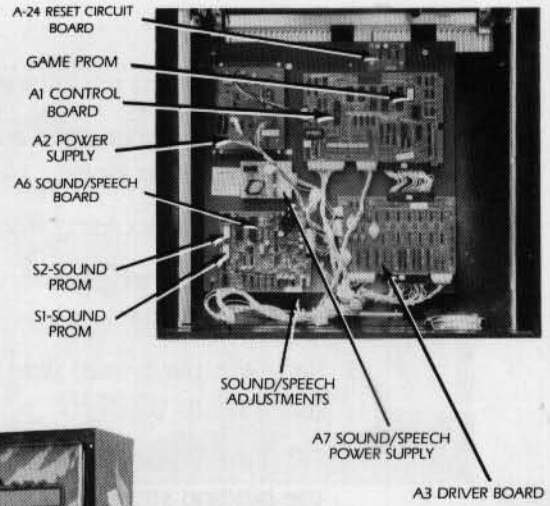
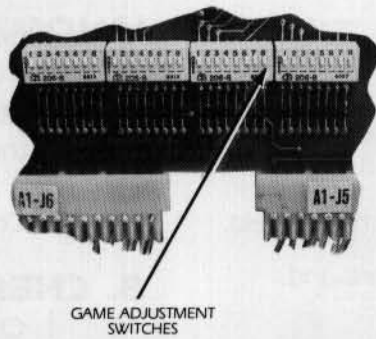
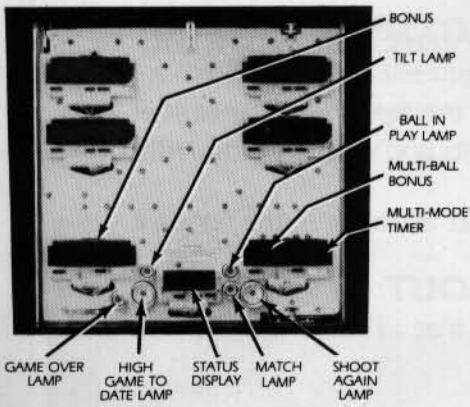



# I. INSTALLATION

## A. SET-UP

1. Bolt the legs to the cabinet.
2. Open the cabinet door and loosen the front moulding locking arm.
3. Remove the moulding from the playfield.
4. Slide the cabinet glass forward and remove it.
5. Raise the playboard, slide it forward and rest it on its supports.
6. From the inside of the cabinet, remove the binding strap from the power cord. Feed the cord to the outside of the cabinet through the black plastic line cord housing.
7. Place the lightbox atop the pedestal and engage the holding bracket.

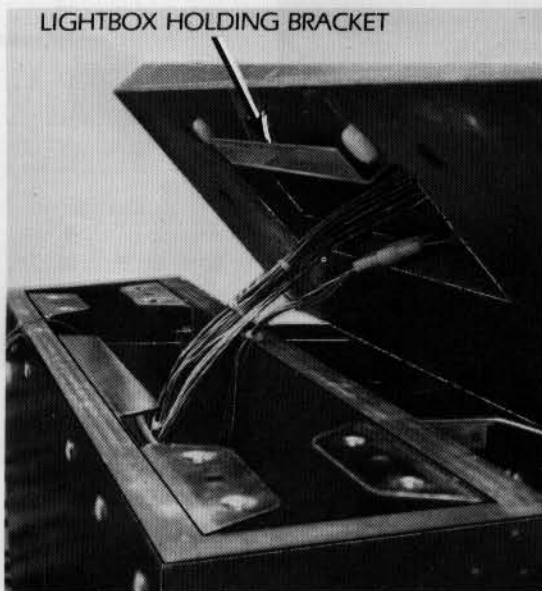

8. Unlock the lightbox and remove the backglass.
9. Loosen and lower the shipping bracket at the top center of the lightbox insert panel.

10. Lift the insert; then swing it out.
11. Secure the lightbox to the cabinet with the bolts and washers provided.
12. Connect all cables in the lightbox.

## B. CHECK-OUT

1. Check that all cables are clear of moving parts.
2. Check for any loose wires.
3. Check switches for loose solder or other foreign matter.
4. Be certain all fuses are firmly seated.
5. Check transformers for any foreign matter across terminals.
6. Be sure transformer wiring corresponds to the supply voltage.
7. Check the setting of the normally open tilt switch on the underside of the playfield. One blade should be free-floating with a weight on the end.
8. Reassemble and level the game.
9. The plumb-bob tilt can be adjusted by loosening the wing nut and raising the plumb-bob to increase its sensitivity, or lowering it to decrease its sensitivity.  
  
The ball-roll tilt can be adjusted by loosening the front screw or raising the tilt bracket to increase sensitivity, or lowering it to decrease its sensitivity.
10. With the line cord unplugged, drop a coin into one of the chutes. It should be rejected.
11. Plug the game into a properly grounded 3-wire receptacle **ONLY!**
12. Refer to **Section VI** to make all necessary game adjustments.

# I. INSTALLATION

## C. MIDDLE PLAYFIELD REMOVAL

1. Pivot the front end of the upper playfield until it is at least 12 inches above the front of the cabinet.

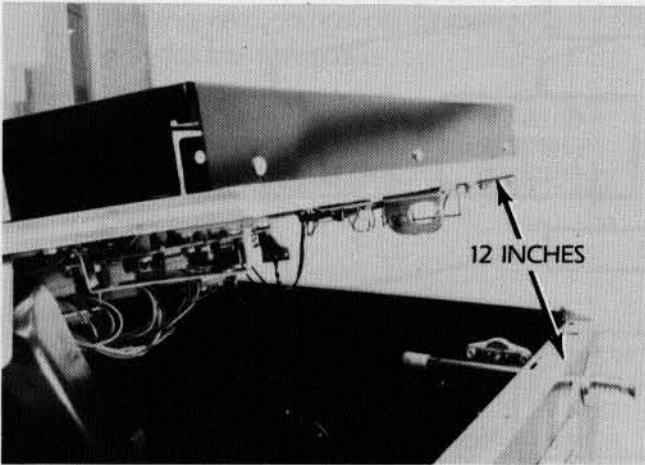

2. Pull the playfield toward you until its back end is 1 to 2 inches from the front end of the playfield support assemblies.

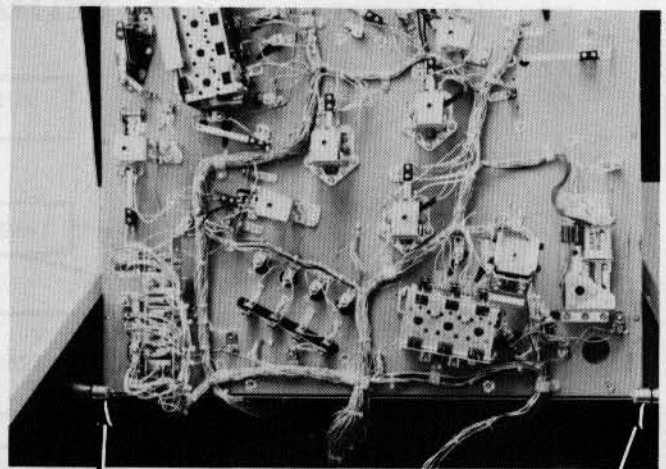

PLAYFIELD  
SUPPORT ASSEMBLY

PLAYFIELD  
SUPPORT ASSEMBLY

3. The playfield can now be pivoted back until it rests on the lightbox, or, after disconnecting its wiring harness, it can be totally removed.

## II. INITIALIZATION, III. GAME OPERATION

### II. INITIALIZATION

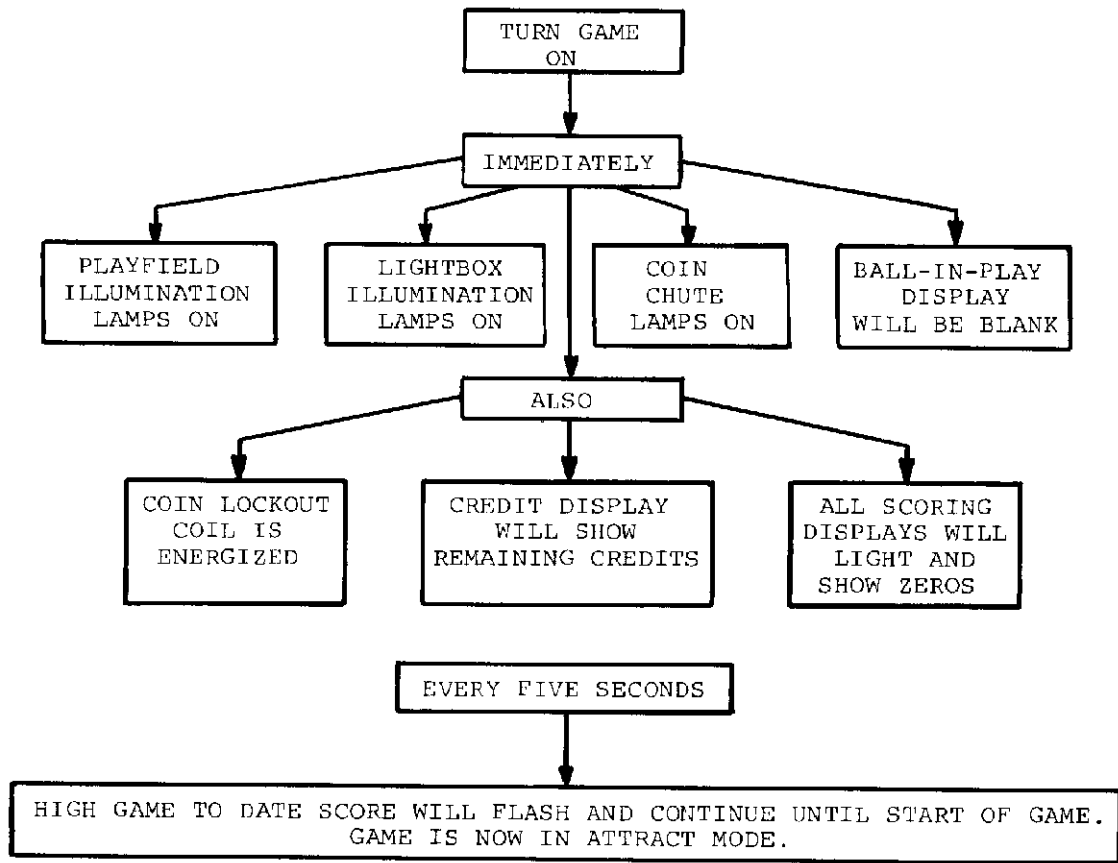

### III. GAME OPERATION

#### A. GAME START

All 3 balls must be in the ball return trough to start a game.

1. Insert coins into coin chute.
  - a. Coin chute tune is played.
  - b. Total credits are displayed in status display.
2. Press Credit Button to start game.
  - a. Credit tune is played.
  - b. Total credits displayed decrease by one.
3. All playfield features reset.
4. The first player score display flashes two zeros.
5. When the ball is released to the shooter, the playfield-controlled lamps flash.

#### B. FIRST PLAYER

1. First player's score display flashes two zeros.
2. The other players' displays are now blank.
3. A "1" appears on the ball-in-play display.
4. When the ball enters the outhole, any bonus earned is scored.

#### C. ADDITIONAL PLAYERS

1. Additional players are indicated by two zeros (not flashing) in each corresponding player's display.
2. After the maximum number of players are added, or no more credits remain, the Credit Button has no effect.

### III. GAME OPERATION

3. Additional players can be added anytime the first player's ball is still in play. If the Credit Button is pressed after the first player's first ball has entered the outhole, all players' scores will be erased with the first player's score display showing a flashing zero, indicating a new game only for the first player.

#### D. EXTRA BALLS

1. When the SHOOT AGAIN lamp is lit, neither the player-up nor the ball-in-play display changes when the ball enters the outhole.
2. Only one extra ball per ball-in-play is given.

#### E. TILT MODE

1. Tilting the game results in a loss of ball in play.
2. When the game is tilted, all the playfield lamps go off.
3. All accumulated bonus and bonus multipliers are lost.

#### F. SLAM MODE

1. If the normally closed slam switch (located inside front door) is opened, the entire game is ended for all players.

2. The GAME OVER lamp comes on.
3. The entire switch matrix is inactive for three seconds.
4. All coins will be rejected if dropped into any coin chute during the three-second delay.
5. If the match feature exists (dependent on Switch #26), a replay can be won even if the game is slammed.
6. Game returns to the attract mode.

#### G. GAME OVER

1. When the last ball enters the outhole, the GAME OVER lamp continually flashes.
2. A random number appears in the ball-in-play display. If this number matches the last two digits in any player's score, a replay (dependent on Switch #27) is awarded.
3. HGTD is periodically flashed in all players' displays. When a score higher than this is achieved, an award (dependent on Switches #23 and #24) is given.
4. All of the target banks will reset.



## IV. GAME PLAY AND SCORING

### SPECIAL

- Completing the top spot target sequence twice lights SPECIAL.
- Right outlane awards SPECIAL.

### EXTRA BALL

- Completing the right spot target bank sequence once (3 ball) or twice (5 ball) lights EXTRA BALL.
- Rollunder awards EXTRA BALL when lit.

### MULTI—BALL PLAY

- Completing the center drop target bank lights the CAPTIVE CAVE for capture. Completing the left drop target bank lights the CAPTIVE PIT for capture after a ball has been captured in the CAPTIVE CAVE.
- After a ball has been captured in the CAPTIVE PIT the third ball hitting any switch will release the first two for three ball multi-ball play.
- After capturing a ball in the CAPTIVE CAVE, due to one of the multi-ball return lanes, hitting any switch will release the ball for two ball multi-ball play.
- At the end of multi-ball the player receives the bonus times multiplier and if the multi-mode level has not been reached, then he receives the sixth player score times 1x.

### BALL SAVE

- BALL SAVE can be enabled by:
  - Completing the top spot target sequence twice.
  - Completing any drop target sequence.
  - Completing the right spot target sequence once (3 ball) or twice (5 ball).

### MULTIPLIERS

- Completing the 3 drop target bank and either of the 5 drop target bank awards 2 x multiplier.
- Completing the 3 drop target bank and both 5 drop target bank awards 3 x multiplier.

### MULTI-MODE FEATURE

If the multimode levels are reached (50,000 for 2 ball and 70,000 for 3 ball) then the player receives 2 or 3 ball multi-ball for a period of time based on the sixth player display value.

During play in multi-mode, the sixth player display will decrement at a slower rate when more balls

are on the table. As more balls are lost the display will decrement faster. As the display is decremented, the player receives these decremental units as score.

- When the multi-ball bonus display reaches zero the playfield goes dead and waits for the balls to drain. At this time the ball is over and the player advances unless the player shooting had previously won an extra ball. If so, the player then will shoot his extra ball.

### KICKING RUBBERS

- Scores 30 points.

### TEN POINT SWITCHES

- Scores 10 points.

### POP BUMPER

- Scores 3,000 points (3 ball) or 300 points (5 ball) when lit.
- Scores 1,000 points (3 ball) or 100 points (5 ball) when unlit.

### LEFT OUTLANE

- Score 5,000 points.

### RIGHT OUTLANE

- Scores 10,000 points
- When lit awards special and resets top spot Targets.

### RETURN LANES

- Scores 3,000 points lit or 500 points unlit.
- Lit left inside rollover lights right spinner for one shot.
- Lit right inside rollover lights left spinner for one shot.
- Lit left outside return lights rollunder for one shot. The ball landing in CAPTURE CAVE is captured for MULTI—BALL play.
- Lit right outside return lights CAPTURE BALL for one shot. The ball landing in CAPTURE CAVE is captured for MULTI-BALL play.

### SPINNERS

- Scores 2,000 points lit or 300 points unlit.
- Adds bonus.

### LEFT SIDE SPOT TARGETS

- Scores 2,000 points each.
- Top lights right return and bottom lights left return.

## IV. GAME PLAY AND SCORING , V. SOUND/SPEECH BOARD (A6)

### IV. GAME PLAY AND SCORING

#### ROLLUNDER

- Scores 5,000 points.
- When lit awards EXTRA BALL.

#### TOP SPOT TARGET BANK

- Scores 2,000 points when lit or scores 500 points when unlit or flashing.
- Hitting each target twice lights SPECIAL and enables BALL SAVE.

#### RIGHT SPOT TARGET BANK

- Scores 2,000 points when lit or 500 points when flashing.
- Lights EXTRA BALL and enables BALL SAVE after hitting each once (3 ball) or each twice (5 ball).

#### DROP TARGET BANKS

- Scores 2,000 points lit or 300 points unlit.
- Lights target and adds bonus.
- Completing any bank enables BALL SAVE.
- Completing the 3-bank lights inside return lanes.

- Completing middle bank enables CAPTURE CAVE for capture.
- Completing left bank enables CAPTURE PIT for capture after a ball has been captured in CAPTURE CAVE.

#### CAPTURE CAVE/PIT

- Scores 5,000 points
- CAPTURE enabled when flashing.

#### OTHER FEATURES

- Regular bonus is displayed on a bonus display.
- In single ball play nothing accumulates on the bonus display. When ball drains after non-multi-ball play, the player receives bonus times multiplier.
- If a player achieves multi-ball, the multi-mode bonus display, starts accumulating points at the rate of 1,000 times the number of balls on the table, if two or more balls are present. The targets that give these points are the drop targets and the two sets of four spot targets.

### V. SOUND/SPEECH BOARD (A6)

SPEECH	OCCURRENCE
"BALL SAVE"	When ball save is initiated.
"SHOOT SPOT TARGETS"	At random after 3 targets of either bank have been lit.
"YOU'RE CLOSE"	At random after 40,000 or 60,000 points have been scored on the multi-mode bonus display.
"MULTI-MODE ACHIEVED"	After multi-mode has been earned.
"SHOOT CAPTIVE CAVE"	At random either after its lamp is lit or after the outside return has been activated.
"SHOOT CAPTIVE PIT"	At random after its lamp is lit.
"FIRE"	When a ball is released to the shooter.

# VI. GAME ADJUSTMENTS

## A. CONTROL BOARD SWITCH ADJUSTMENTS

NOTE: The following switch adjustments pertaining to system 80A only. There are 32 switches on the control board which permit adjustment of the game parameters. These switches are contained in four packages of eight switches each, as shown below.

### COIN CHUTE COMBINATIONS SYSTEM 80A

SWITCHES					COIN CHUTE ADJUSTMENTS	
S1	S2	S3	S4	S5	Left Coin Chute	Right Coin Chute
S9	S10	S11	S12	S13	Center Coin Chute	
S17	S18	S19	S20	S21	CREDITS/COINS	
OFF	OFF	OFF	OFF	OFF	1/1	
OFF	OFF	OFF	OFF	ON	2/1	
OFF	OFF	OFF	ON	OFF	3/1	
OFF	OFF	OFF	ON	ON	4/1	
OFF	OFF	ON	OFF	OFF	5/1	
OFF	OFF	ON	OFF	ON	6/1	
OFF	OFF	ON	ON	OFF	7/1	
OFF	OFF	ON	ON	ON	8/1	
OFF	ON	OFF	OFF	OFF	9/1	
OFF	ON	OFF	OFF	ON	10/1	
OFF	ON	OFF	ON	OFF	1/2	
OFF	ON	OFF	ON	ON	2/2	
OFF	ON	ON	OFF	OFF	3/2	
OFF	ON	ON	OFF	ON	4/2	
OFF	ON	ON	ON	OFF	5/2	
OFF	ON	ON	ON	ON	6/2	
ON	OFF	OFF	OFF	OFF	7/2	
ON	OFF	OFF	OFF	ON	8/2	
ON	OFF	OFF	ON	OFF	9/2	
ON	OFF	OFF	ON	ON	10/2	
ON	OFF	ON	OFF	OFF	1/3	
ON	OFF	ON	OFF	ON	2/3	
ON	OFF	ON	ON	OFF	1/4	
ON	OFF	ON	ON	ON	3/4	
ON	ON	OFF	OFF	OFF	1/5	

\*All of the above do not give credits until the last coin is inserted

SWITCHES 6, 7 AND 8 \_\_\_\_\_ SPARES

SWITCH 14 \_\_\_\_\_ COIN CHUTE 1 & 2 CONTROL  
ON ..... Same  
OFF ..... Separate

SWITCHES 15 16 \_\_\_\_\_ MAXIMUM CREDITS  
OFF OFF ..... 8  
OFF ON ..... 10  
ON OFF ..... 15  
ON ON ..... 25

SWITCH 22 \_\_\_\_\_ PLAYFIELD SPECIAL  
ON ..... Extra Ball  
OFF ..... Special

SWITCHES 23 24 \_\_\_\_\_ HIGH GAME TO DATE AWARDS  
OFF OFF ..... None  
OFF ON ..... None  
ON OFF ..... 2 Replay  
ON ON ..... 3 Replay

SWITCH 25 \_\_\_\_\_ BALLS/GAME  
ON ..... 3  
OFF ..... 5

SWITCH 26 \_\_\_\_\_ MATCH  
ON ..... On  
OFF ..... Off

SWITCH 27 \_\_\_\_\_ REPLAY LIMIT  
ON ..... 1  
OFF ..... No Limit

SWITCH 28 \_\_\_\_\_ NOVELTY  
ON ..... Yes  
OFF ..... Normal

SWITCH 29 \_\_\_\_\_ GAME MODE  
ON ..... Extra Ball  
OFF ..... Replay

SWITCH 30 \_\_\_\_\_ 3RD COIN CHUTE CREDIT CONTROL  
ON ..... Add 9  
OFF ..... No Effect

SWITCHES 31 32 \_\_\_\_\_ LIBERAL/CONSERVATIVE  
Not Used

### ADDITIONAL COIN CHUTE COMBINATIONS CREDIT INCENTIVES

ALL OF THE BELOW CANNOT HAVE 9 CREDITS ADDED BASED ON SWITCH 30

SWITCHES					COIN/CREDIT GIVEN	COIN/CREDIT GIVEN	COIN/CREDIT GIVEN	COIN/CREDIT GIVEN	COIN/CREDIT GIVEN	TOTAL COIN/TOTAL CREDIT
S1	S2	S3	S4	S5	Left Coin Chute	Right Coin Chute	Center Coin Chute			
S9	S10	S11	S12	S12						
S17	S18	S19	S20	S21						
ON	ON	OFF	OFF	ON	1st/1	2nd/2				2/3
ON	ON	OFF	ON	ON	1st/0	2nd/1	3rd/1	4th/1	=	4/3
ON	ON	OFF	ON	ON	1st/0	2nd/1	3rd/0	4th/2	=	4/3
ON	ON	ON	OFF	OFF	1st/1	2nd/1	3rd/1	4th/2	=	4/5
ON	ON	ON	OFF	ON	1st/1	2nd/2	3rd/1	4th/3	=	4/7
ON	ON	ON	ON	OFF	1st/1	2nd/2	3rd/2	4th/2	=	4/7
ON	ON	ON	ON	ON	1st/0	2nd/0	3rd/1	4th/0	5th/1	5/2

## VI. GAME ADJUSTMENTS

### A. POST ADJUSTMENTS

None

### B. SOUND ADJUSTMENTS

The speaker output is controlled by the potentiometer mounted on the fuse/knocker panel.

Turning the potentiometer counter clockwise will decrease the volume. Turning it clockwise will increase the volume.

The potentiometer is accessible through the front door.

**IMPORTANT:** Each of the potentiometers installed on the sound/speech board have been factory adjusted. The potentiometer settings should never be changed except when performing the recommended calibration procedure.

#### SWITCH BANK (SB1) SETTINGS:

SB 1-1	USED IN SELF-TEST ONLY.
SB 1-2	NOT USED.
SB 1-3	SB 1-4 Attract Mode
OFF	OFF Disabled
ON	OFF Every 10 Seconds.
OFF	ON Every 2 Minutes.
ON	ON Every 4 Minutes.
SB 1-5	ON Background Sound enabled.
	OFF Background Sound disabled.
SB 1-6	NOT USED.
SB 1-7	NOT USED.
SB 1-8	NOT USED.

### C. KICKING TARGET ADJUSTMENT

Push the PLUNGER down until it "bottoms out" in the coil HOUSING. Push the TARGET

FACE in the direction of the arrow shown until it makes contact with the vertical leg of the KICKER CAM. The vertical leg of the cam is located behind the kicking target and is not shown.

Observe that the gap between the SWITCH contacts is at least 1/32nd of an inch. If not, bend the switch's BACKING BLADE in the proper direction.

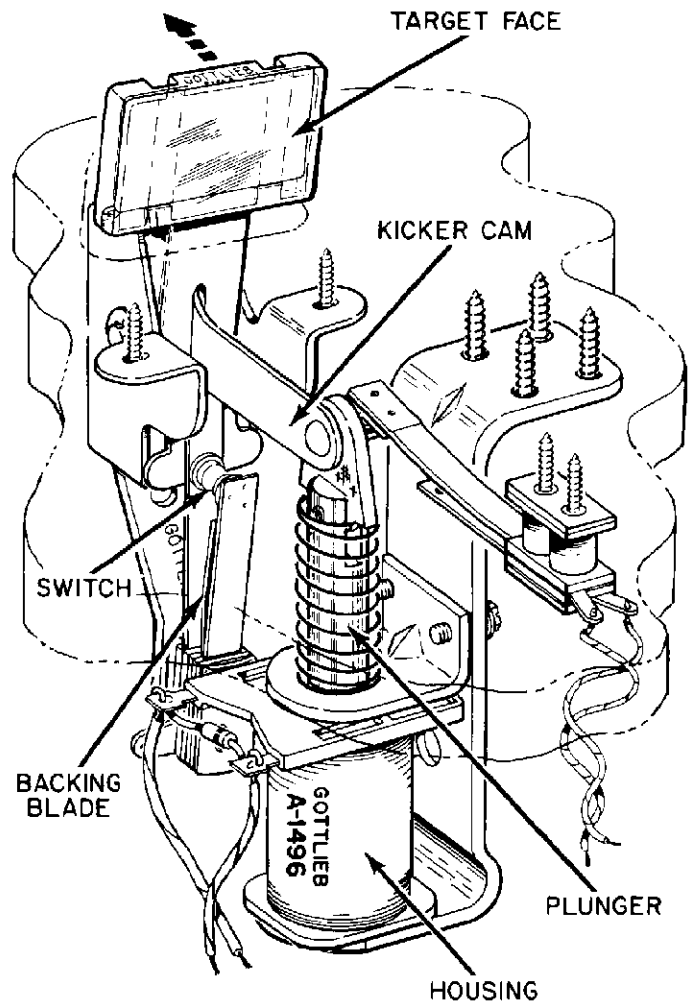

## VII. BOOKKEEPING AND SELF TEST

The circuitry in this game helps the operator perform many bookkeeping and Self/Test functions. These functions are accessed by the Self/Test Switch inside the front door and information is displayed on the players' and credit displays. Section VII, A details the Bookkeeping system, while Section VII, C details the Self/Test operation. The Flow Chart in Section VII, B gives the general order and function of both bookkeeping and Self/Test steps.

### A. BOOKKEEPING SYSTEM 80A

- See Flow Chart for Bookkeeping Assignments.
- Bookkeeping Steps (01-15) are displayed in the credit display and the 3rd and 4th player's score display.
- Information for the particular bookkeeping step displayed will appear in the 1st player's score display.
- All bookkeeping information is checked against itself to insure that it is correct. If any data is invalid or bad, that information will flash while it is displayed.

### I. STEPPING THROUGH BOOKKEEPING

1. Press the SELF-TEST button inside the front door.

Double zeros (00) should appear in the designated bookkeeping step displays.

2. Press the SELF-TEST button again. Step 01 and its information will be displayed.
3. Pressing the SELF-TEST button will increment the bookkeeping step number and the appropriate information will be displayed.

**NOTE:** If the SELF-TEST button is not pressed within 60 seconds of each step, the game will return to the attract mode.

Pressing the SELF-TEST button after Step 15 will start the SELF-TEST function (Step 16-20). At this point Bookkeeping cannot be reentered by pressing the SELF-TEST button. To reenter, turn the game OFF/ON, open the slam switch, close a tilt switch, or wait 60 seconds. The game will return to the attract mode. Then press the SELF-TEST button.

4. To exit from Bookkeeping at any time:
  - a. Wait 60 seconds **or**
  - b. Turn power OFF/ON **or**
  - c. Open slam switch **or**
  - d. Close a tilt switch.

### II. HOW TO SET BOOKKEEPING INFORMATION TO ZERO

1. For a Particular Bookkeeping Step
  - a. Advance Bookkeeping so the step to be zeroed is displayed.
  - b. Press the replay button. Notice all zeros will appear in the 1st player's display
  - c. Press the SELF-TEST button. This will enter zeros into memory. Note: If the SELF-TEST button is not pressed, the bookkeeping memory will retain its information.
2. Zeroing All Bookkeeping Steps Except #11, 12, 13 and 14.  
(These are the replay level and high game to date scores).
  - a. Go to Step # 15.
  - b. Press the credit button. Step 15 data will zero.
  - c. Press the SELF-TEST button.
  - d. Zeroing is complete.



# VII. BOOKKEEPING AND SELF TEST

## III. HOW TO RESET HIGH SCORE LEVELS OR HIGH GAME TO DATE SCORES

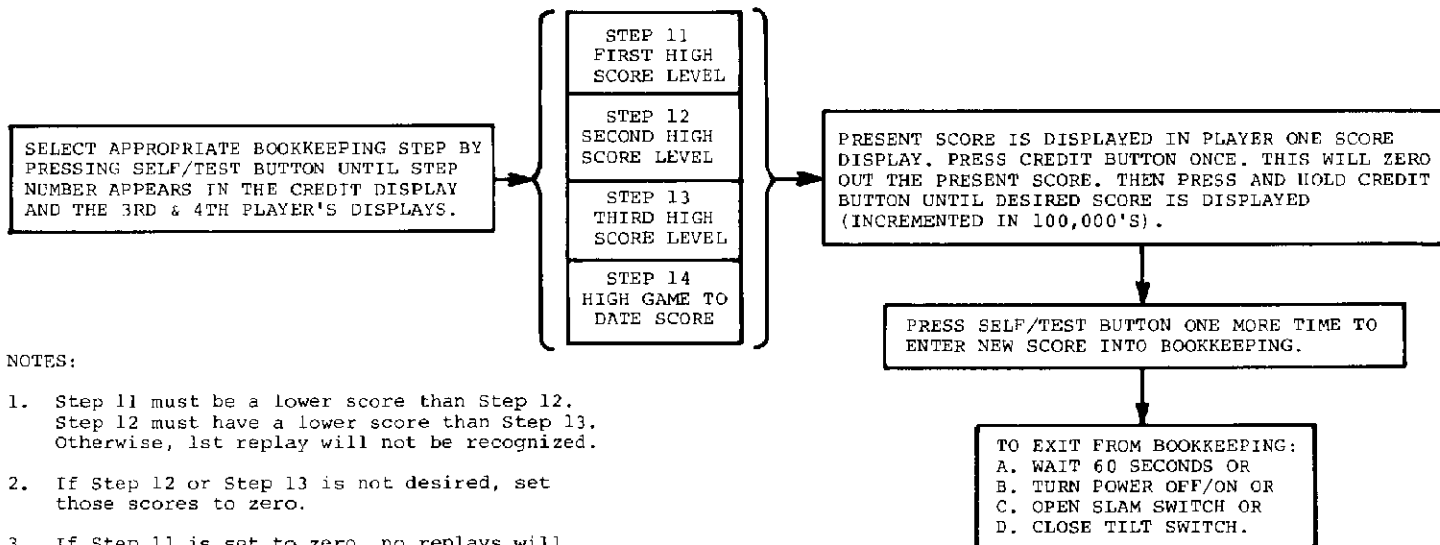

### NOTES:

1. Step 11 must be a lower score than Step 12. Step 12 must have a lower score than Step 13. Otherwise, 1st replay will not be recognized.
2. If Step 12 or Step 13 is not desired, set those scores to zero.
3. If Step 11 is set to zero, no replays will be awarded, no matter what the settings are for Step 12 and Step 13.

# VII. BOOKKEEPING AND SELF TEST

## B. FLOWCHART

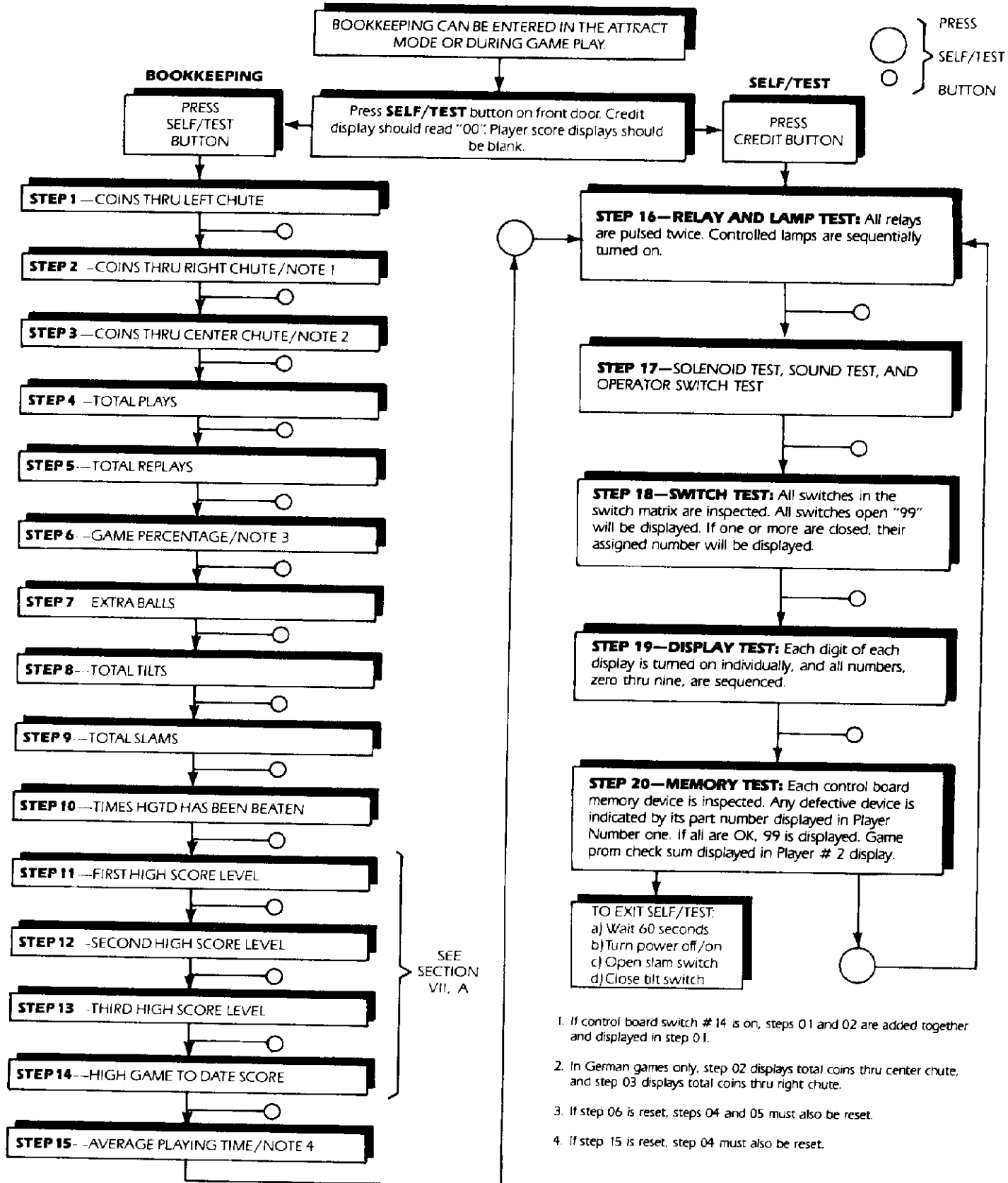

## VII. BOOKKEEPING AND SELF TEST

### C. SELF/TEST

- Steps 16 through 20 are SELF/TEST or game tests the operator can use for quick troubleshooting.
  - All the tests are explained in the flow chart.
  - Each test can be repeated by pressing the replay button on the front door. This starts the test for another 60 seconds.
  - If the SELF/TEST button or the replay button is not pressed within 60 seconds, the game will return to the attract mode.
- Test information is displayed in the third and fourth player score displays and the status display.

#### EXAMPLE:

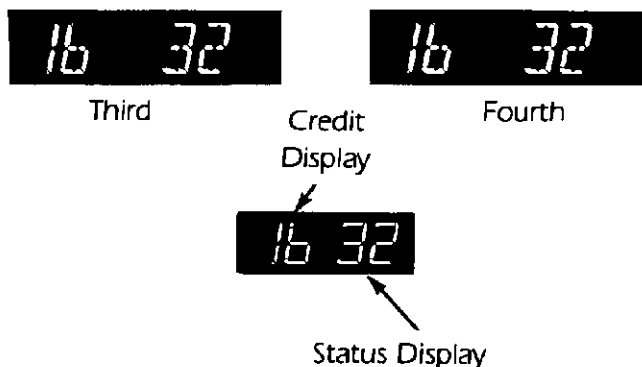

#### STEP 16—RELAY AND LAMP TEST

- a. Relay Test-All relays are pulsed twice in the following order:

	A3 Driver Board Transistor Assignment (See Schematic)
Q (Game Over) Relay	A3J3 PIN #A Q1
T (Tilt) Relay	A3J3 PIN #B Q2
Coin Lockout Relay	A3J5 PIN #2 Q3
B (Ball Save) Relay	A3J6 PIN #3 Q54

- b. Lamp Test-Lamps are sequentially strobed. Lamp assignment numbers appear in the third and fourth player's score display and the status display.

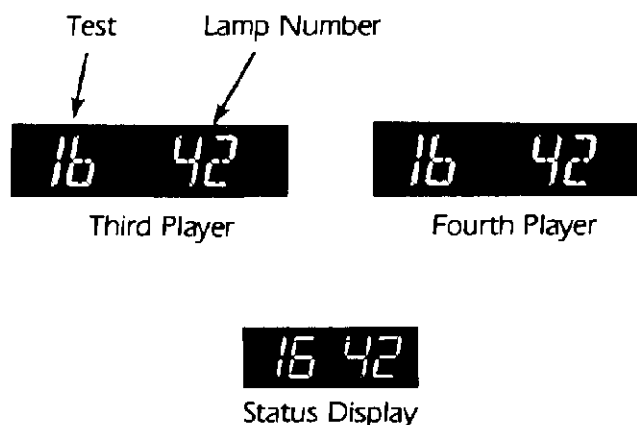

Lamp number (L9, L16, etc.) can be referenced to the Driver Board Schematic where the specific transistor for each lamp can be identified.

To repeat test, push the credit button. To advance to test # 17, push the Self/Test Button.

#### STEP 17—SOLENOID TEST, SOUND TEST, OPERATOR SWITCH TEST.

- a. Solenoid Test-Each solenoid on the playfield is sequentially pulsed. The solenoid number displayed identifies which solenoid is being tested. The following chart lists solenoid assignments.

NUMBER DISPLAYED	ASSIGNMENT	A3 DRIVER BOARD TRANSISTOR ASSIGN. SEE SCHEMATIC
SOL 1	Top Drop Target Bank	Q60
SOL 2	Top Ball Kicker	Q57/58
SOL 3	Hole	Q54
SOL 4	Ball Save Relay	Q55
SOL 5	Left Drop Target Bank	Q61/62
SOL 6	Right Drop Target Bank	Q63/64
SOL 7	Not Used	
SOL 8	Knocker	Q53
SOL 9	Outhole	Q59

- b. Sound Test-Immediately after the solenoid test, the sound enable signals (inputted to the A6 Sound Board) will be tested in the following order:

# VII. BOOKKEEPING AND SELF TEST

## SOUND NUMBER ENABLE DISPLAYED

S16	17 (combination S1 & S16)
S8	8
S2	2
S4	4
S1	1

## A3 DRIVER BOARD TRANSISTOR ASSIGN. SEE SCHEMATIC

A3J2	PIN 9
A3J5	PIN 7
A3J5	PIN 5
A3J5	PIN 1
A3J5	PIN 6

c. The first and second player's score displays show hexadecimal representative of the operator switch positions. Converting hexadecimal to binary will give the switch positions in binary form.

### CONVERSION TABLE

0 = OFF    1 = ON

DISPLAYED HEXIDECIMAL	DECIMAL	BINARY
--------------------------	---------	--------

0	0	0	0000
1	1	1	0001
2	2	2	0010
3	3	3	0011
4	4	4	0100
5	5	5	0101
6	6	6	0110
7	7	7	0111
8	8	8	1000
9	9	9	1001
A	10	1010	
B	11	1011	
C	12	1100	
D	13	1101	
E	14	1110	
F	BLANK	1111	

### EXAMPLE:

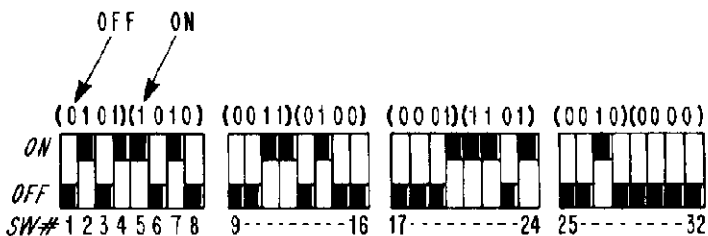

### DISPLAYED

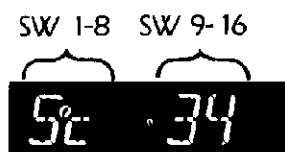

First Player

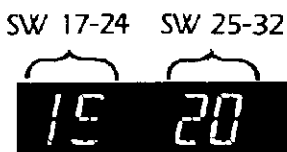

Second Player

## Checking Switches

1) Switch all odd number switches to the ON position, and all even switches to the OFF position. Display should show:



First Player



Second Player

2) Switch all even numbered switches to the ON position and all odd switches to the OFF position. Display should show:



First Player



Second Player

To repeat test # 17, push the credit button.

To advance to test # 18, push the Self/Test switch.

## STEP 18—SWITCH TEST



Third Player



Fourth Player

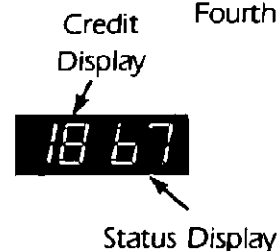

- 1) All switches open. 99 will be displayed. (Note: The slam switch is not part of the switch test (normally closed).
- 2) Switch(es) closed. Designated number(s) will be sequentially displayed. The last switch number will remain displayed, unless test is repeated.

## VII. BOOKKEEPING AND SELF TEST

**STEP 19—DISPLAY TEST:** Each digit of each display is individually turned on, and numbers zero through nine are sequenced.

- Test number is not displayed.

**NOTE:** On the second and fourth player displays only, the least significant digits are strobed first. Then the most significant digits and the remaining digits are sequentially strobed. This is normal operation.

**STEP 20—MEMORY TEST -** Each control based memory device is checked. If all are good, a 99 will be displayed.

If a memory chip is defective, a corresponding number in the following chart will be displayed:

### NUMBER DISPLAYED

99  
5 10 1  
2332-1  
2332-2  
6532-1  
6532-2  
6532-3  
27 16\*

### CHIP ASSIGNMENT/ DESCRIPTION

All Memory Good  
Z5 Bookkeeping Ram  
U2 Background Rom  
U3 Background Rom  
U4 Ram  
U5 Ram  
U6 Ram  
Prom 1 Game E Prom

Player #2 displays the check sum for the game prom in hexadecimal. Refer to the conversion Table for interpretation.

To repeat test #20, push the credit button. To advance to Step # 16, push the Self/Test button.

\* James Bond (658) and later System 80 games up to and including Haunted House will display 764 1- 1 for a bad 27 16 game prom.



# VIII. OPTIONS, IX. GENERAL INFORMATION

## VIII. OPTIONS

There are no liberal or conservative adjustments for this game.

## IX. GENERAL INFORMATION

### A. PRINTED CIRCUIT BOARDS ARE DESIGNATED AS FOLLOWS:

- A1 - Control Board
- A2 - Power Supply
- A3 - Driver Board
- A4 - Timer Display
- A5 - Status Display
- A6 - Sound/Speech Board
- A7 - Sound/Speech Power Supply
- A8 - Pop Bumper Driver Boards
- A14 - Score Display
- A24 - Reset Board

Printed circuit board connectors will be labeled AX-JX. For example, A3-J44 is the connector J4 on the driver board (A3).

### B. WIRE COLORS ARE SHOWN AS NUMBERS:

- 0 Black
- 1 Brown
- 2 Red
- 3 Orange
- 4 Yellow
- 5 Green
- 6 Blue
- 7 Purple
- 8 Slate
- 9 White

For example, 688 is a BLUE-SLATE-SLATE striped wire.

### C. FUSES

F1	Sound/Speech Power Supply	12VAC	1/2 Amp
F2	Power Supply	10VAC	5 Amp SLO-BLO
F3	Displays	60VAC	1/4 Amp SLO-BLO
F4	Solenoids	25VAC	8 Amp SLO-BLO
F5	Controlled Lamps	8VAC	10 Amp
F6	Playboard Illumination	6.3VAC	10 Amp
F7	Lightbox Illumination	6.3VAC	12 Amp
F8	Sound/Speech Power Supply	+24 VDC	1 Amp SLO-BLO
F9	Primary Fuse	110VAC	5 Amp SLO-BLO
	Primary Fuse	220VAC	2.5 Amp SLO-BLO
F10	3 Position Drop Target Bank and Outhole	+24 VDC	1 Amp SLO-BLO
F11	Ball Release	+24 VDC	1 Amp SLO-BLO
F12	Hole Kicker	+24 VDC	1 Amp SLO-BLO
F13	Left/Right Target Banks and Top Ball Kicker	+24 VDC	2 Amp SLO-BLO
F14	Top Pop Bumper	+24 VDC	2 Amp SLO-BLO
F15	Right Pop Bumper	+24 VDC	2 Amp SLO-BLO
F16	Left Pop Bumper	+24 VDC	2 Amp SLO-BLO

## IX. GENERAL INFORMATION

### D. COIL CHART

<b>SOLENOID COILS</b>					
PART NUMBER	GENERAL USAGE	RESISTANCE (OHMS)	NUMBER OF TURNS	WIRE GAUGE	WRAPPER COLOR
A-1496	KICKING TARGET KICKING RUBBERS POP BUMPERS	2.95	635	#23	Yellow
A-4893	UP KICKER POP BUMPERS BALL KICKER	2.1	535	#22	Red
A-5194	UP KICKER GONG KICKING TARGETS	4.5	780	#24	Blue
A-5195	CONTACT KICKER KNOCKER HOLE KICKER	12.3	1305	#26	White
A-16570	HOLE KICKER, OUTHOLE	15.5	1450	#27	Green
A-17875	FLIPPERS	2.8/40.0	560/1100	#24/31	Yellow
A-17891	5 BANK RESET	3.35	850	#22	White
A-18102	3 BANK RESET, 7 BANK RESET USES 2	9.0	1430	#24	Red
A-18318	4 BANK RESET	6.7	1130	#24	Orange
A-19300	BALL KICKER	7.8	1075	#25	Orange
A-20095	SUPER FLIPPER	1.55/35.5	450/900	#22/31	Red
A-21741	UP KICKER	2.5	575	#23	Orange
<b>RELAY COILS</b>					
A-16890	Q, T, AND COIN LOCKOUT RELAYS	231.0	4000	#35	Orange
A-20558	GATE RELAY	156.0	3400	#34	White
A-18642	MEMORY/ DROP TARGETS	58.0	1590	#33	White

\* Coils may vary from game to game. Check game manual for exact coil usage.



# X. WIRING AND SCHEMATIC DIAGRAMS, PARTS LISTS

## TABLE OF CONTENTS

	PAGE
<b>CONTROL BOARD (A1)</b>	
<b>COMPONENT LOCATION AND PARTS LIST</b> .....	<b>20</b>
<b>SCHEMATIC DIAGRAM</b> .....	<b>21</b>
<b>DRIVER BOARD (A3)</b>	
<b>COMPONENT LOCATION AND PARTS LIST</b> .....	<b>24</b>
<b>SCHEMATIC DIAGRAM</b> .....	<b>25</b>
<b>SOUND/SPEECH BOARD (A6)</b>	
<b>COMPONENT LOCATION AND PARTS LIST</b> .....	<b>27</b>
<b>SCHEMATIC DIAGRAM</b> .....	<b>28</b>
<b>POP BUMPER DRIVER BOARD (A8)</b>	
<b>COMPONENT LOCATION AND PARTS LIST</b> .....	<b>30</b>
<b>SCHEMATIC DIAGRAM</b> .....	<b>30</b>
<b>LIGHT BOX WIRING</b> .....	<b>31</b>
<b>7 DIGIT DISPLAY (A14)</b>	
<b>COMPONENT LOCATION AND PARTS LIST</b> .....	<b>33</b>
<b>SCHEMATIC DIAGRAM</b> .....	<b>33</b>
<b>6-DIGIT DISPLAY (A4)</b>	
<b>COMPONENT LOCATION AND PARTS LIST</b> .....	<b>34</b>
<b>SCHEMATIC DIAGRAM</b> .....	<b>34</b>
<b>4-DIGIT DISPLAY (A5)</b>	
<b>COMPONENT LOCATION AND PARTS LIST</b> .....	<b>35</b>
<b>SCHEMATIC DIAGRAM</b> .....	<b>35</b>
<b>RESET BOARD (A24)</b>	
<b>COMPONENT LOCATION AND PARTS LIST</b> .....	<b>36</b>
<b>SCHEMATIC DIAGRAM</b> .....	<b>37</b>
<b>PLAYBOARD</b>	
<b>PLAYBOARD SWITCH AND LAMP ASSIGNMENT</b> .....	<b>38</b>
<b>PLAYBOARD SWITCH MATRIX</b> .....	<b>39</b>
<b>PLAYBOARD ILLUMINATION AND SOLENOIDS</b> .....	<b>40</b>
<b>POWER SUPPLY (A2)</b>	
<b>COMPONENT LOCATION AND PARTS LIST</b> .....	<b>42</b>
<b>SCHEMATIC DIAGRAM</b> .....	<b>43</b>
<b>SOUND/SPEECH BOARD POWER SUPPLY (A7)</b>	
<b>COMPONENT LOCATION AND PARTS LIST</b> .....	<b>44</b>
<b>SCHEMATIC DIAGRAM</b> .....	<b>44</b>
<b>BOTTOM BOARD AND CABINET SCHEMATIC</b> .....	<b>45</b>

# X. WIRING AND SCHEMATIC DIAGRAMS, PARTS LISTS

## CONTROL BOARD (A1) COMPONENT LOCATION

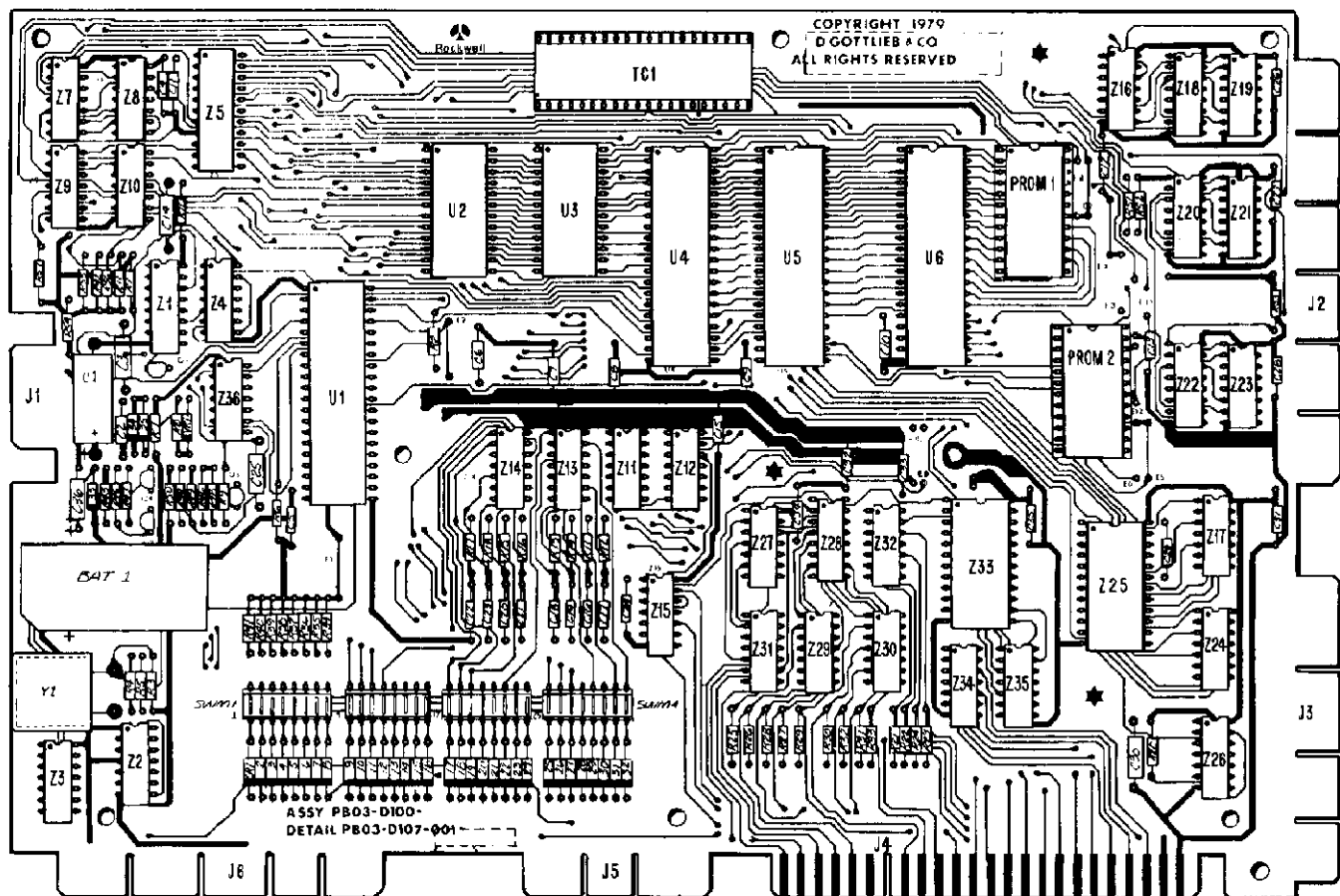

## CONTROL BOARD (A1) PARTS LIST

REFERENCE	DESCRIPTION	PART NUMBER	REFERENCE	DESCRIPTION	PART NUMBER
BAT.1	Battery—3.6V	326R10-002	U3	ROM	XO-327
C1	Capacitor, 100 mfd., 10V		U4, U5, U6	RIOT	R6532-18
C2,	Capacitor, .01 mfd., 50V		VR1	Zener Diode—3.0V, 5%	1N5225B or 1N5987B
C4-C13,			Y1	Crystal, 3.579545 MHZ	333R08-001
C15-C24,			Z1	IC—CMOS—Dual 1 Shot	SCL4528B
C26-C29,			Z2	IC—Dual Flip Flop	SN7474N
C31-C35			Z3, Z11,	IC—Hex Inverter	SN7404N
C3, C14,	Capacitor, .1 mfd., 50V		Z12, Z16,		
C25, C30			Z17, Z24,		
C36	Capacitor, 10 mfd.	10V.TNT	Z26, Z27,		
CR1-CR35	Diode, GP	1N4148	Z34, Z35		
Q1, Q4	Transistor—PNP	MPS-A70	Z4	IC—CMOS—Quad 2 Input "AND"	SCL4081B
Q2, Q3	Transistor, NPN (Motorola)	2N440	Z5	IC—Static Ram	S510-L
R1, R6,	Resistor, 3.0K ohm, 5%, 1/4W		Z7	IC—Hex Inverter	SN74LS04N
R11-R24,			Z8	IC—2 Input "NOR"	SN7402N
R42, R45,			Z9, Z13,	IC—2 Input "NAND"	SN7400N
R46, R48,			Z14		
R51-R57			Z10	IC—Open Collector Inverter	SN74LS05N
R2,	Resistor, 4.7K ohm, 5%, 1/4W		Z15	IC—2 Input—"OR"	SN7432N
R34-R41			Z18, Z20	IC—"D" Flip Flop	SN74175N
R3, R43,	Resistor, 5.6K ohm, 5%, 1/4W		Z22		
R49			Z19, Z21,	IC—4 to 7 Decoder	SN7448N
R4, R5,	Resistor, 2.0K ohm, 5%, 1/4W		Z23		
R44			Z25, Z33	IC—4 to 16 Decoder	SN74154N
R7	Resistor, 62 ohm, 5%, 1/4W		Z28	IC—2-to-4 Decoder	SN74LS139N
R8, R50	Resistor, 180 ohm, 5%, 1/4W		Z29, Z30	IC—Hex Inverter—OC/HV	SN7416N
R9	Resistor, 1K ohm, 5%, 1/4W		Z31	IC—2 Input "AND"	SN7408N
R10	Resistor, 2.8M ohm, 5%, 1/4W		Z32	IC—Hex Buffer—OC	SN7417N
R25-R33	Resistor, 620 ohm, 5%, 1/4W		Z36	IC—CMOS	MM74C04 or
R47	Resistor, 24K ohm, 5%, 1/4W			Socket—DIL, 24 PIN	SCL4069B
SW1-SW4	Dip Switch Pak—B Position	341R31-005		Spacer, Cork	640361-3 131R06-001
TC1	Socket, 40 Pin	640379-3			
U1	CPU	R6502-13			
U2	ROM	XO-326			



NOTE: UNLESS OTHERWISE INDICATED;  
 1. RESISTORS ARE ±5%, 1/4W.  
 2. CAPACITORS ARE .01UF, 50V.  
 3. DIODES ARE TYPE 1N4148.  
 4. REF. DESIGNATION Z6 NOT USED.

SPARE GATES

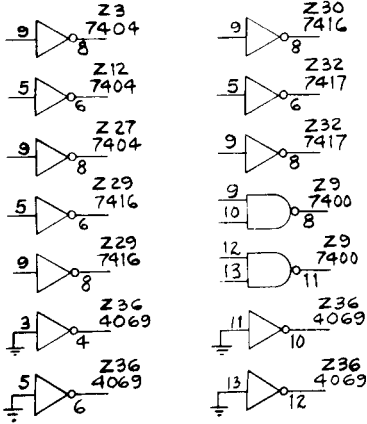

CLOCK LOGIC

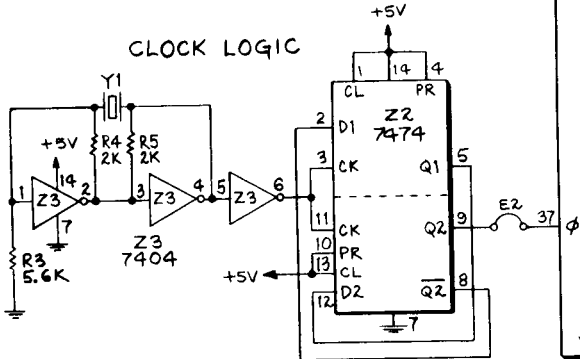

DELAY CIRCUIT

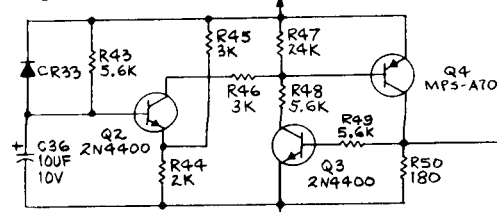

UP/DOWN MEMORY PROTECT LOGIC

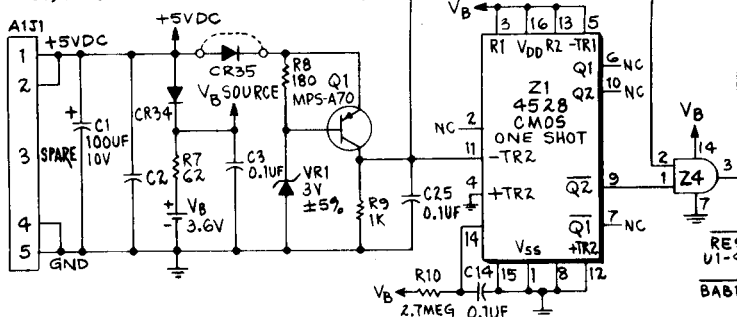

INPUT/OUTPUT DEVICE SELECTION

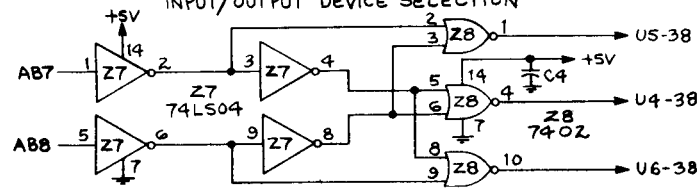

PROM SELECTION

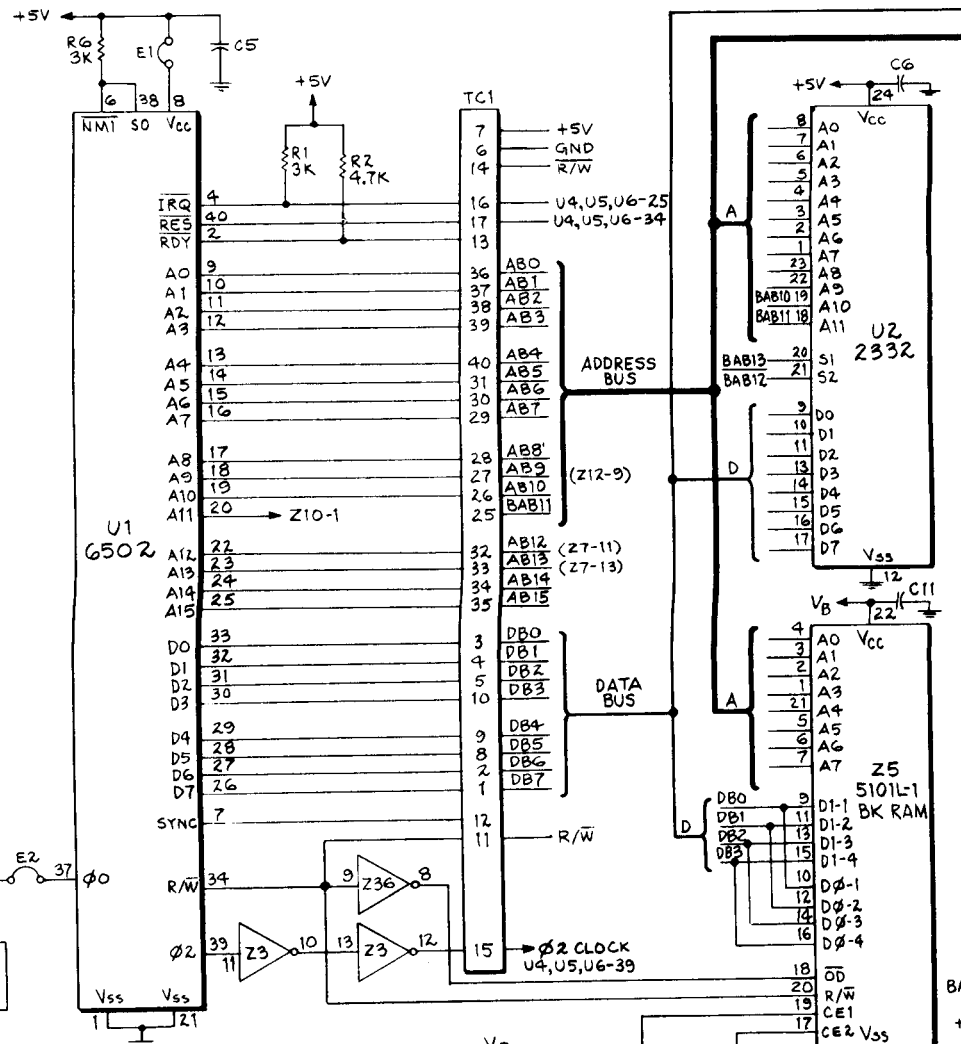
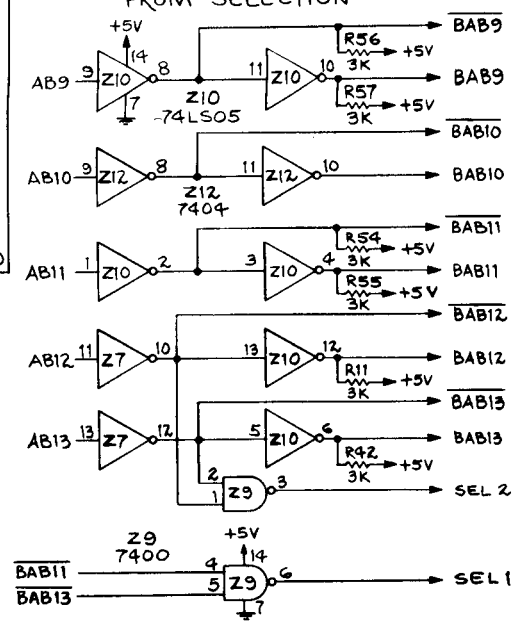

# X. WIRING AND SCHEMATIC DIAGRAMS, PARTS LISTS

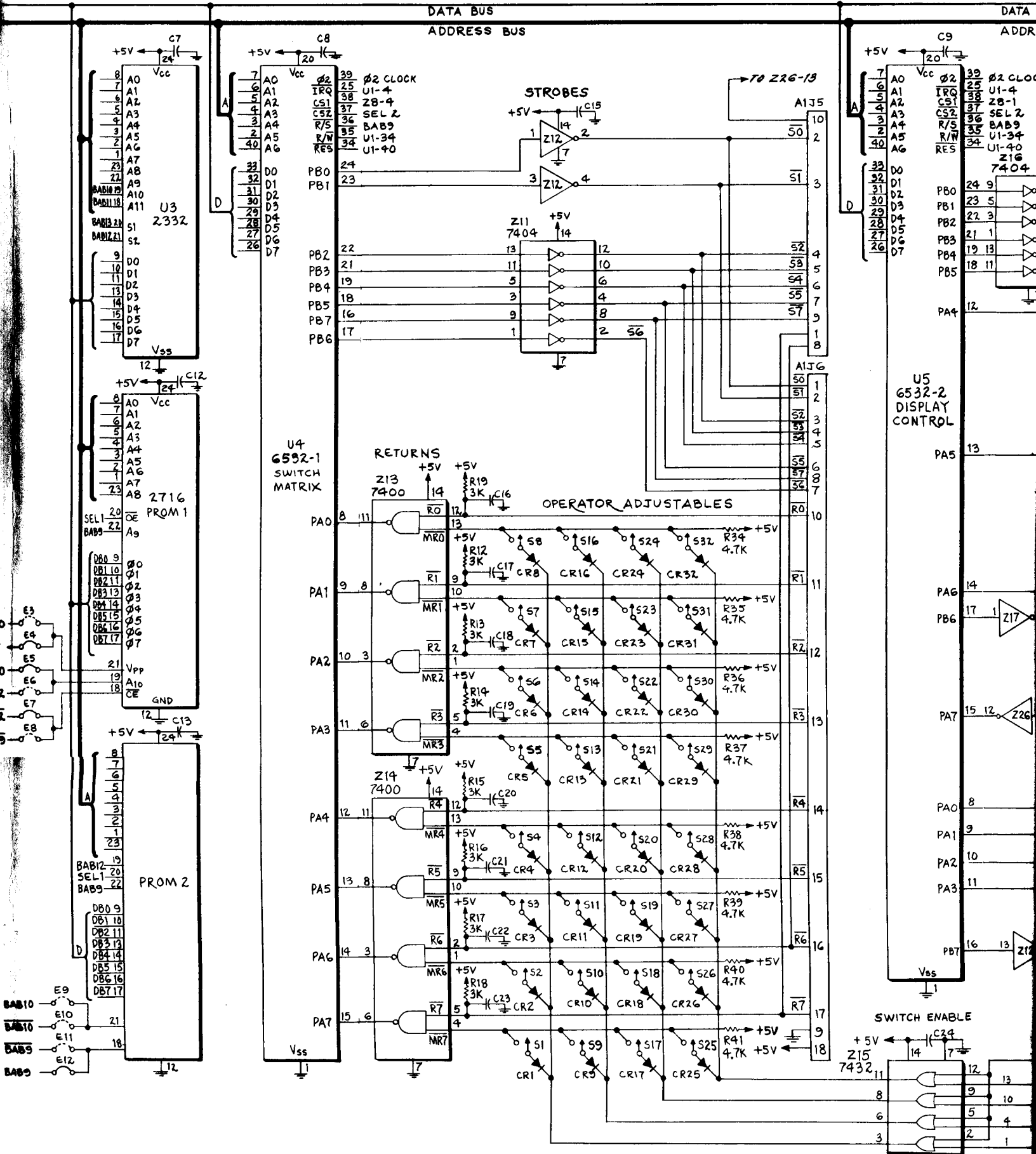



# X. WIRING AND SCHEMATIC DIAGRAMS, PARTS LISTS

## DRIVER BOARD (A3) COMPONENT LOCATION

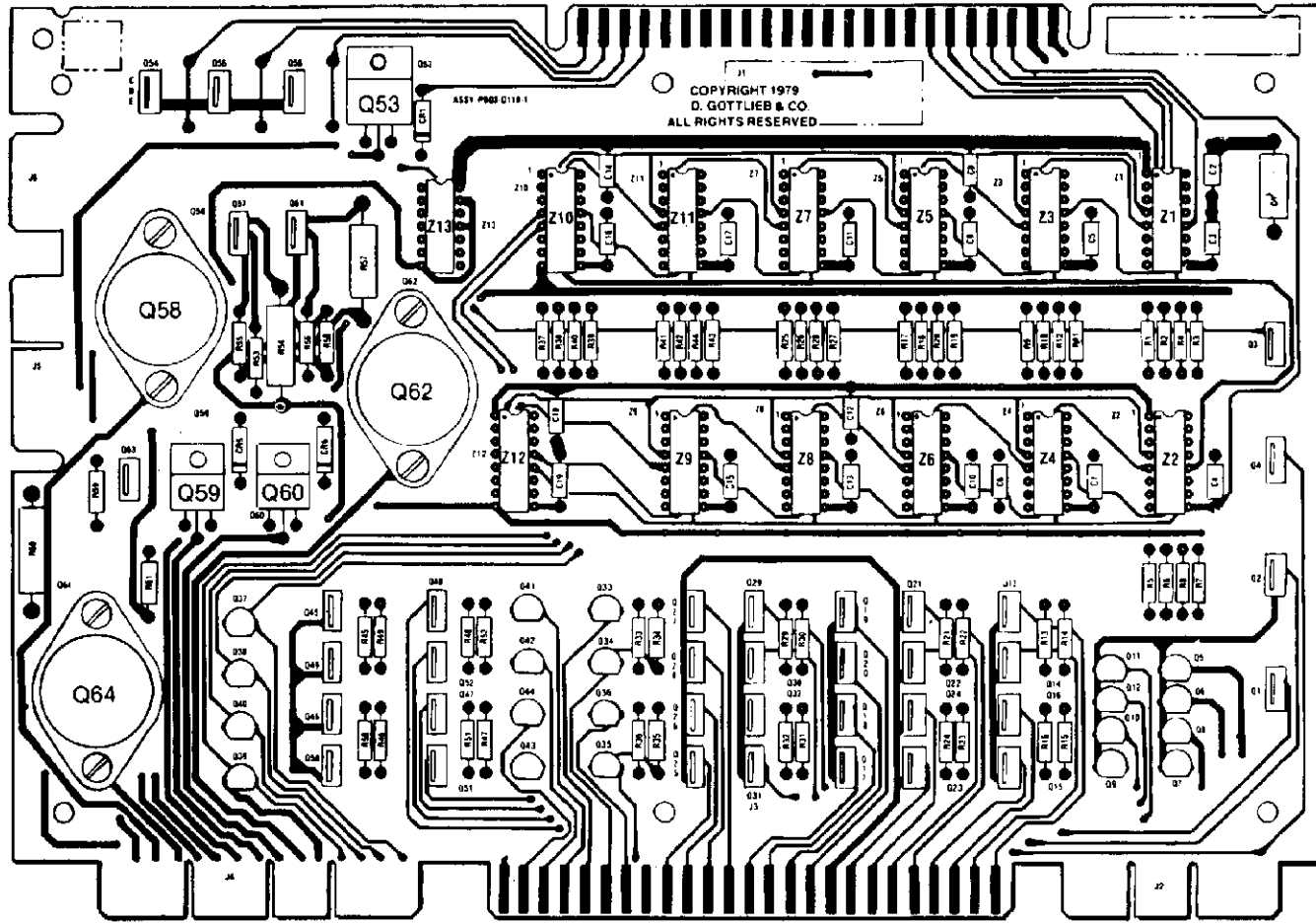

## DRIVER BOARD (A3) PARTS LIST

REFERENCE	DESCRIPTION	PART NUMBER
C1	Capacitor, 10 mfd., 10V— Tantalum	
C2-C19	Capacitor, .01 mfd., 50V	
CR1-CR6	Diode—Silicon	1N4148
R1-R53, R61, R55, R56, R58, R59	Resistor, 1000 ohm, 5%, 1/4W	
R54, R57, R60	Resistor, 9.1 ohm, 5%, 1W	
Q1-Q4, Q13-Q32, Q45-Q52, Q54-Q57, Q63	Transistor, NPN, Darlington	MPS-U45
Q5-Q12, Q33-Q44	Transistor, NPN, Darlington	MPS-A13
Q53, Q59, Q60	Transistor, NPN, Darlington	2N6043
Q58, Q62, Q64	Transistor, NPN	2N3055
Z1-Z12	I.C. Quad "D" Latch Flip Flop	SN74175N
Z13	I.C. Hex Inverter	SN7404N
	Insulator—Thermalloy	43-03-4

NOTE: CR2, 3 and 4 have been replaced with jumper wires.



# X. WIRING AND SCHEMATIC D

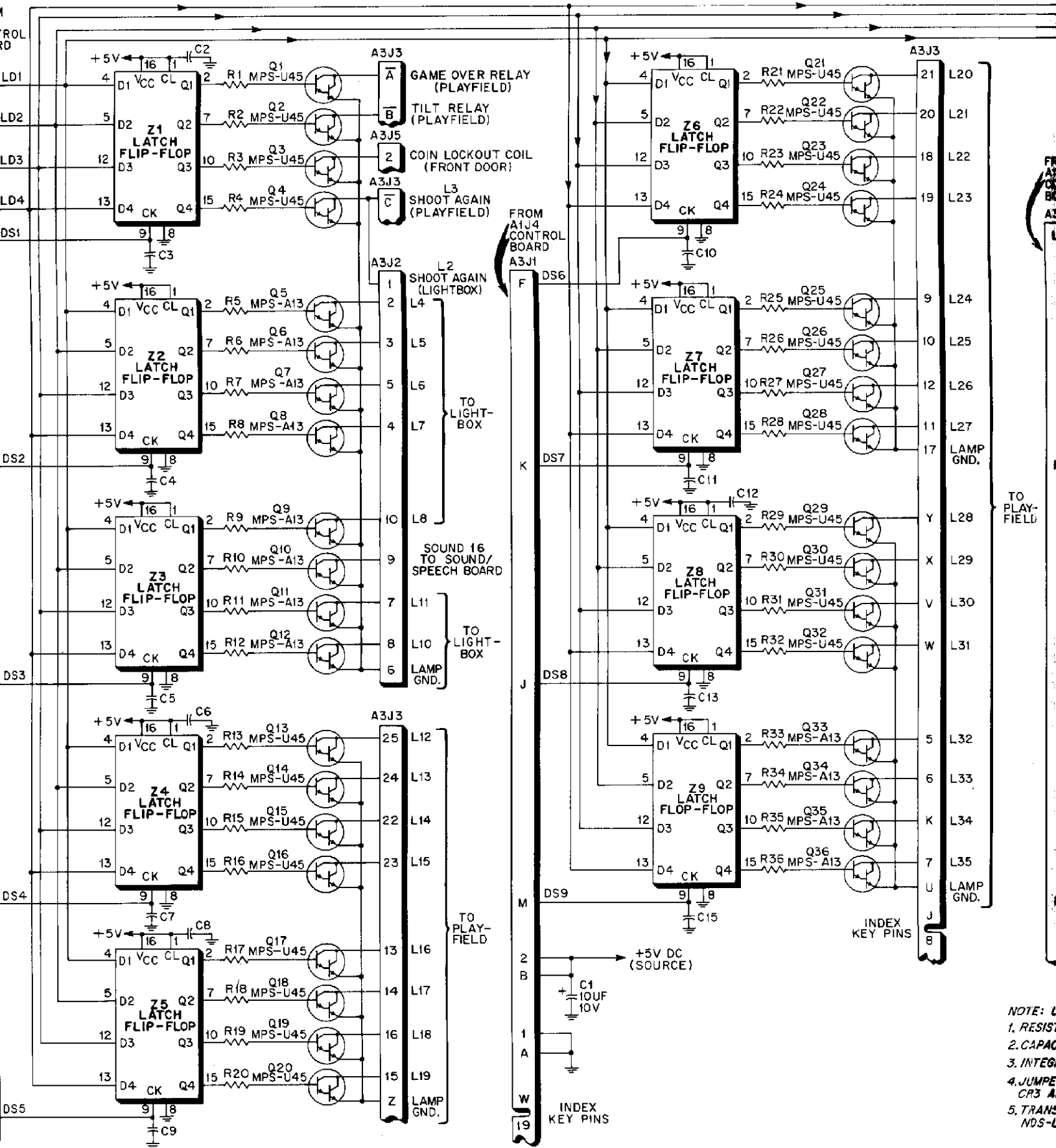

- NOTE: U  
 1. RESISTOR  
 2. CAPACITOR  
 3. INTEGRATED CIRCUIT  
 4. JUMPER  
 5. TRANSISTOR





# X. WIRING AND SCHEMATIC DIAGRAMS, PARTS LISTS

## SOUND/SPEECH BOARD (A6) COMPONENT LOCATION

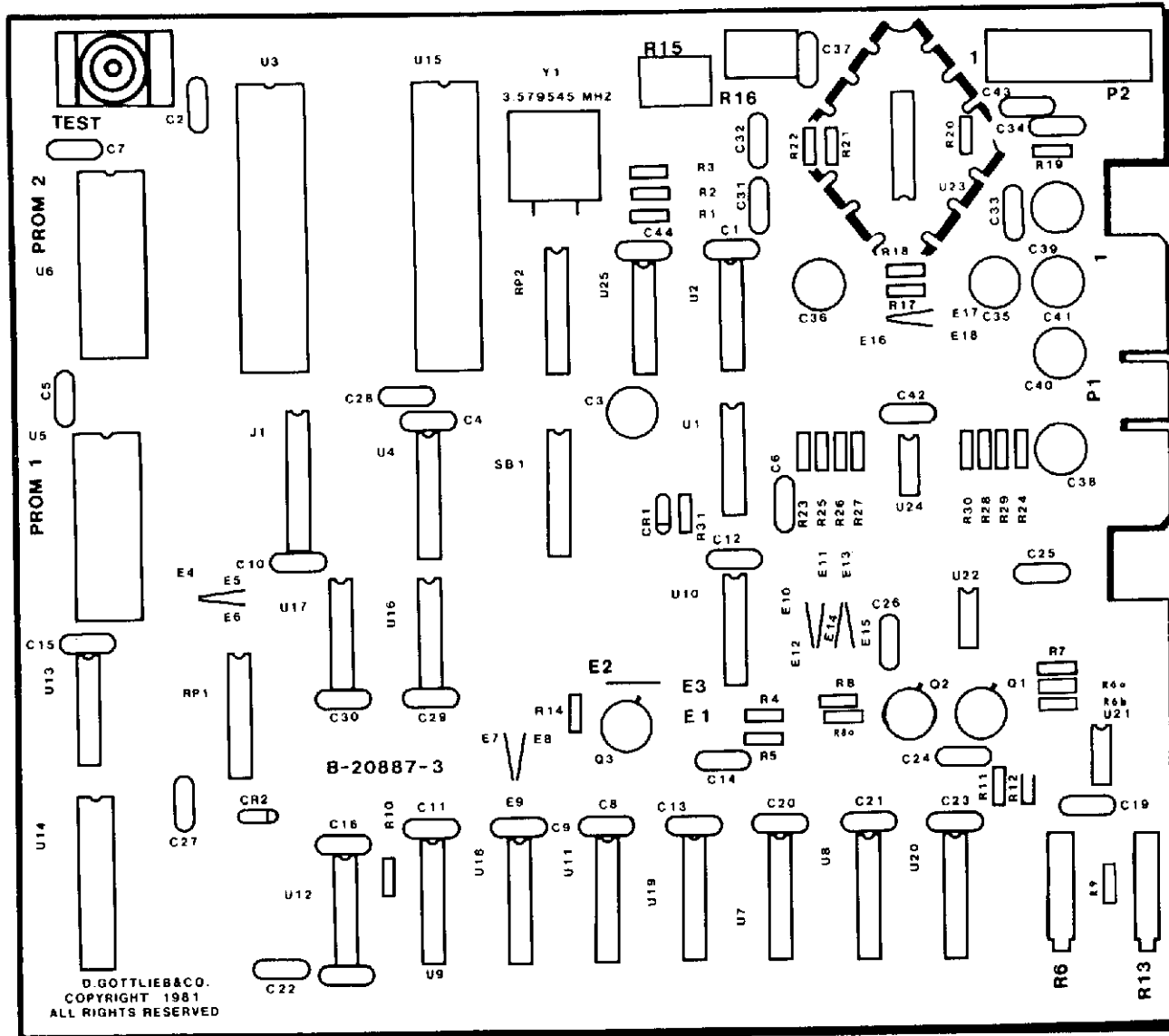

## SOUND/SPEECH BOARD (A6) PARTS LIST

REFERENCE	DESCRIPTION	PART NUMBER	REFERENCE	DESCRIPTION	PART NUMBER
C1, C2	Capacitor, .1 UF 25V, CMD		R18, R21	Resistor, 100K ohm, 1/4W	
C4-C13,			R22	Resistor, 2K ohm, 1/4W, 5%	
C15, C16,			R23-R30	Resistor, 10K ohm, 1/4W	
C19, C20,			R31	Resistor, 3.3K ohm, 1/4W, 5%	
C21, C23			RP1, RP2	Resistor, Dip	4116R-002-222
C25, C26,			SB1	Dip Switch	1008-692
C28-30			SW1	Moment Pushbutton Switch	
C33			U1	IC, Trigger	7414
C31-C32	Capacitor, 0.05 MF, 25V, CMD		U2	IC	SN74LS74N
C42, C44			U3	CPU	R6502-13
C37	Capacitor, 4.7 MF, 25V Tantalum		U4	IC	SN74LS138N
C3, C38-C41	Capacitor, 47 MF, 50V		U5, U6	E Prom	2716
C14, C24	Capacitor, 100 PF, 250V, 20%		U7-U9, U11, U18	IC	SN74L75
C22	Capacitor, 300 PF, CMD		U10	IC	SN74LS02N
C27	Capacitor, 1 UF, 50V, TNT		U12	IC	SN7407N
C36	Capacitor, 470 MF, 35V		U13	IC, Inverter	SN74LS05N
CR1	Diode	1N4148	U14 not used	Voice Chip	SC01
CR2	Diode, Zener	1N5225B	U15	RRIOT	R6532-18
Q1, Q3	Transistor, NPN	2N2222A	U16	IC	SN74LS04N
Q2	Transistor, PNP	2N2907A	U17	IC	SN74LS30N
R1, R4, R5,	Resistor, 5.6K ohm, 1/4W		U19, U20	Converter, PMI	1408A-6P
R11, R12			U21, U22	IC	LM741CP
R2, R3	Resistor, 2K ohm, 1/4W, 5%		U23	IC	LM3795
R6, R13	Potentiometer, 10K, Bourns	3006-103	U24	IC, Dual Comparitor	LM193
R7	Resistor, 10K ohm, 1/4W, 5%		U25	Inverter	7404
R8, R8A, R14	Resistor, 1K ohm, 1/4W, 5%		Y1	Crystal, 3.579545 MHZ	
R6A, R6B	Resistor, 1.8K ohm, 5%, 1/4 watt			Socket 22 Pin Dip	
R9	2.2K ohm, 5%, 1/4W			Socket 24 Pin (2)	640361-3
R10	Resistor, 1.5K ohm, 1/4W, 5%			Socket 40 Pin (2)	640379-3
R15, R16	Potentiometer, 10K, CTS	X20 1R			



NOTE  
 1. UNL  
 RESI  
 2. TL  
 IND  
 3. WIT  
 E1, E  
 SOL  
 271  
 USE



# X. WIRING AND SCHEMA

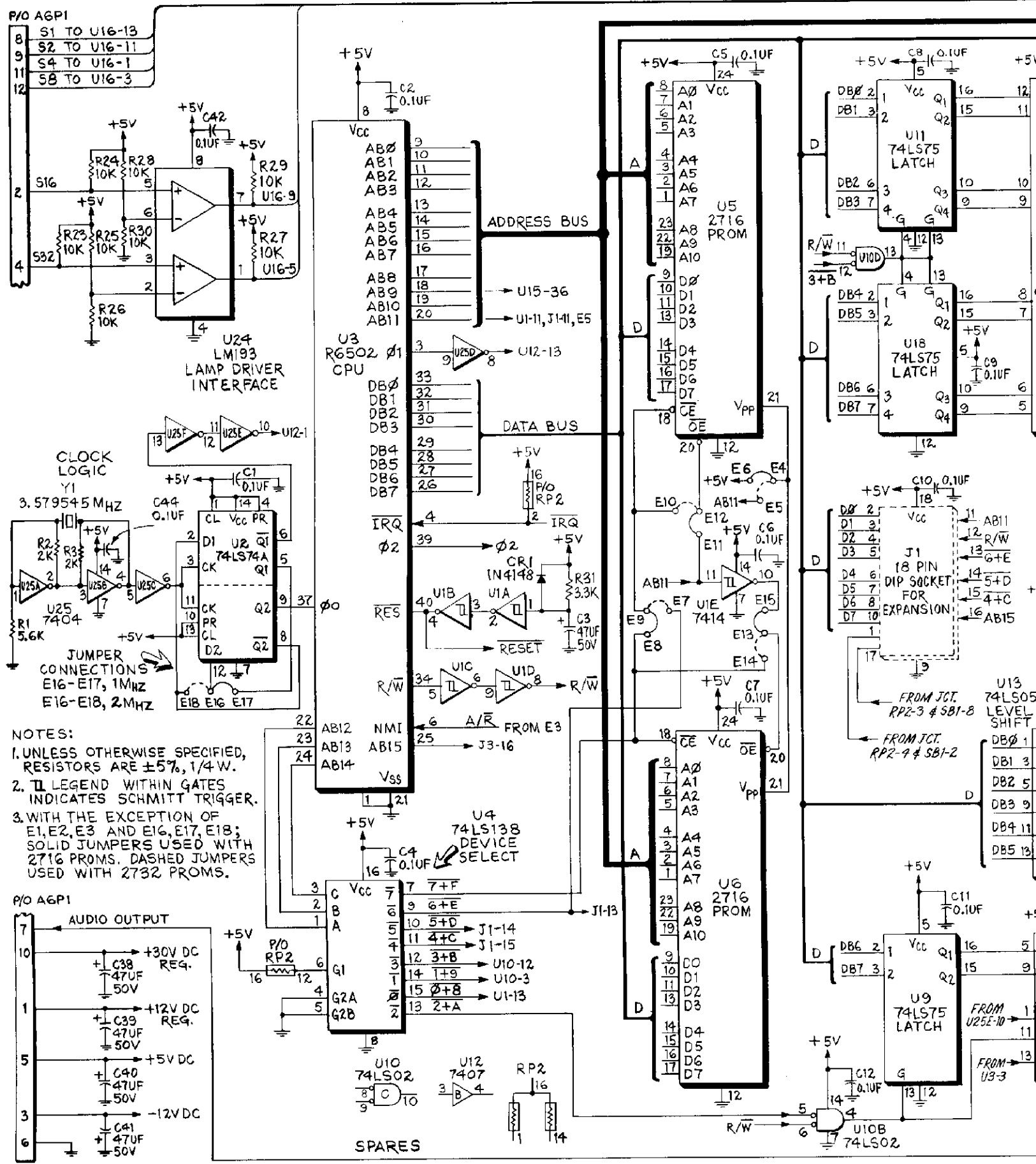

P/O AGP1  
 8 S1 TO U16-13  
 9 S2 TO U16-11  
 11 S4 TO U16-1  
 12 S8 TO U16-3

CLOCK LOGIC  
 Y1  
 3.579545 MHz

JUMPER CONNECTIONS  
 E16-E17, 1MHz  
 E16-E18, 2MHz

- NOTES:  
 1. UNLESS OTHERWISE SPECIFIED, RESISTORS ARE ±5%, 1/4 W.  
 2. □ LEGEND WITHIN GATES INDICATES SCHMITT TRIGGER.  
 3. WITH THE EXCEPTION OF E1, E2, E3 AND E16, E17, E18; SOLID JUMPERS USED WITH 2716 PROMS. DASHED JUMPERS USED WITH 2732 PROMS.

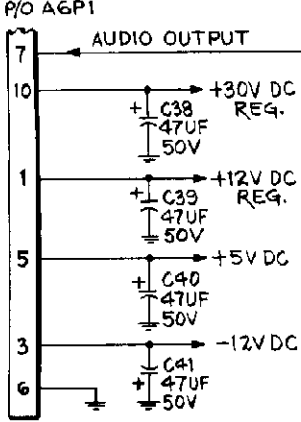

# SCHEMATIC DIAGRAMS, PARTS LISTS

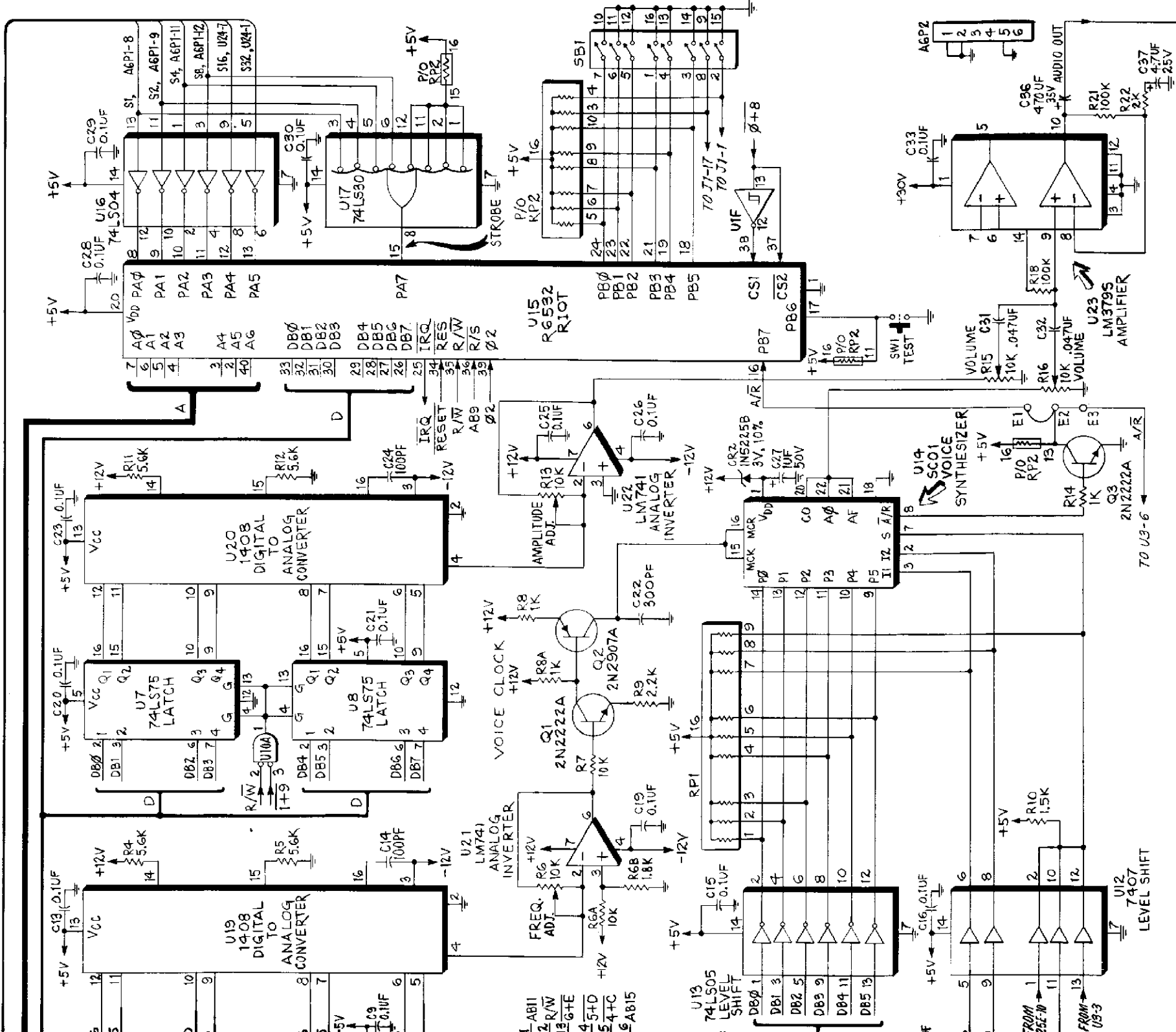

D. GOTTLIEB & CO.  
 TITLE SOUND/SPEECH BOARD AG  
 USED ON  
 4-23-81 E-21337

# X. WIRING AND SCHEMATIC DIAGRAMS, PARTS LISTS

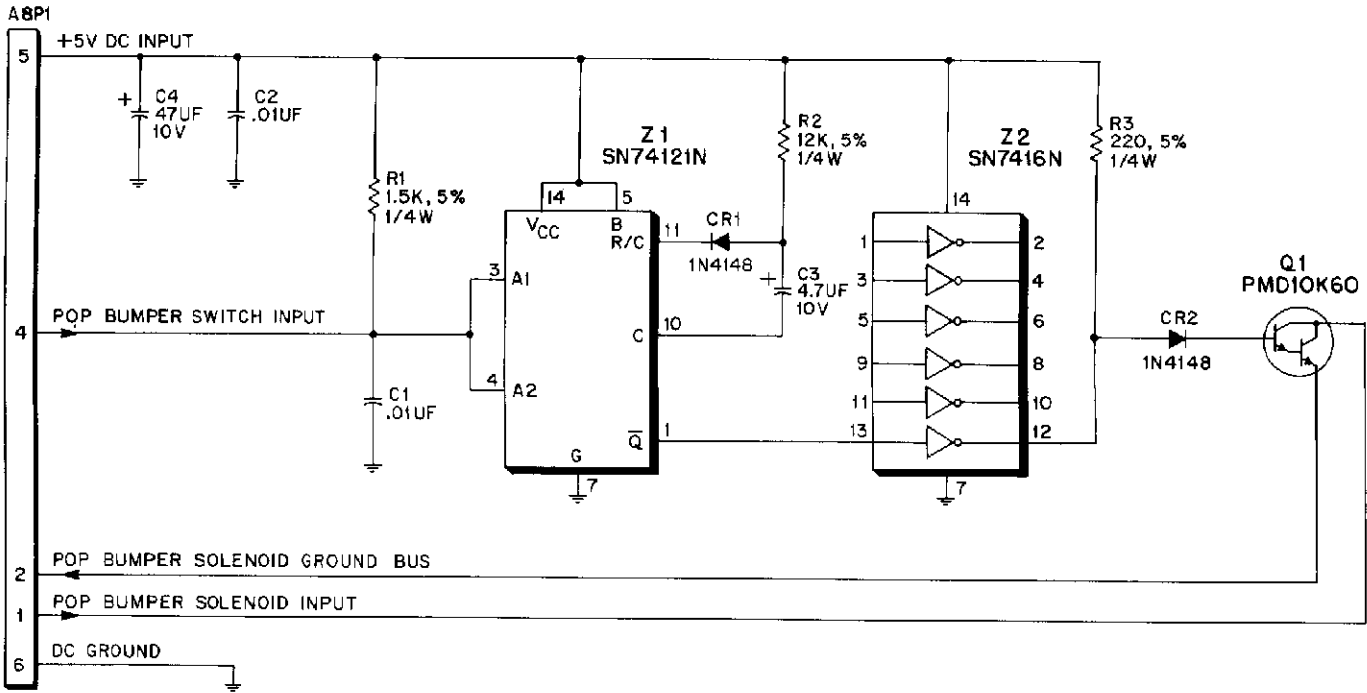

**D. GOTTLIEB & CO.**  
**TITLE POP BUMPER DRIVER BOARD (A8)**  
 USED ON  
 DRAWN BY: 8.1.80 APPROVED: 13.1.12 DATE: 3-3-81 **D-20923**

## POP BUMPER DRIVER BOARD (A8) COMPONENT LOCATION

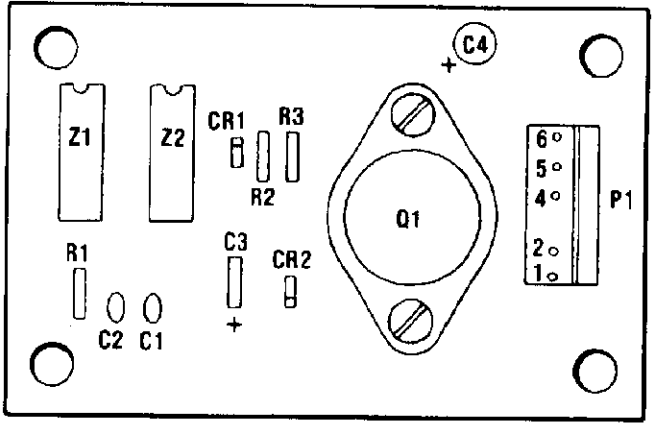

## POP BUMPER DRIVER BOARD (A8) PARTS LIST

REFERENCE	DESCRIPTION	PART NUMBER
C1, C2	Capacitor, .01 mfd., 20%, 100V	
C3	Capacitor, 4.7 mfd., 10%, 10V	
C4	Capacitor, 47 mfd., 10V	
CR1, CR2	Diode	1N4148
P1	Connector	09-65-1061
R1	Resistor, 1.5K ohm, 5%, 1/4W	
R2	Resistor, 12K ohm, 5%, 1/4W	
R3	Resistor, 220 ohm, 1/4W, 5%	
Q1	Transistor — LAMBDA	PMD10K60
Z1	IC	SN74121N
Z2	IC	SN7416N

# X. WIRING AND SCHEMATIC DIA

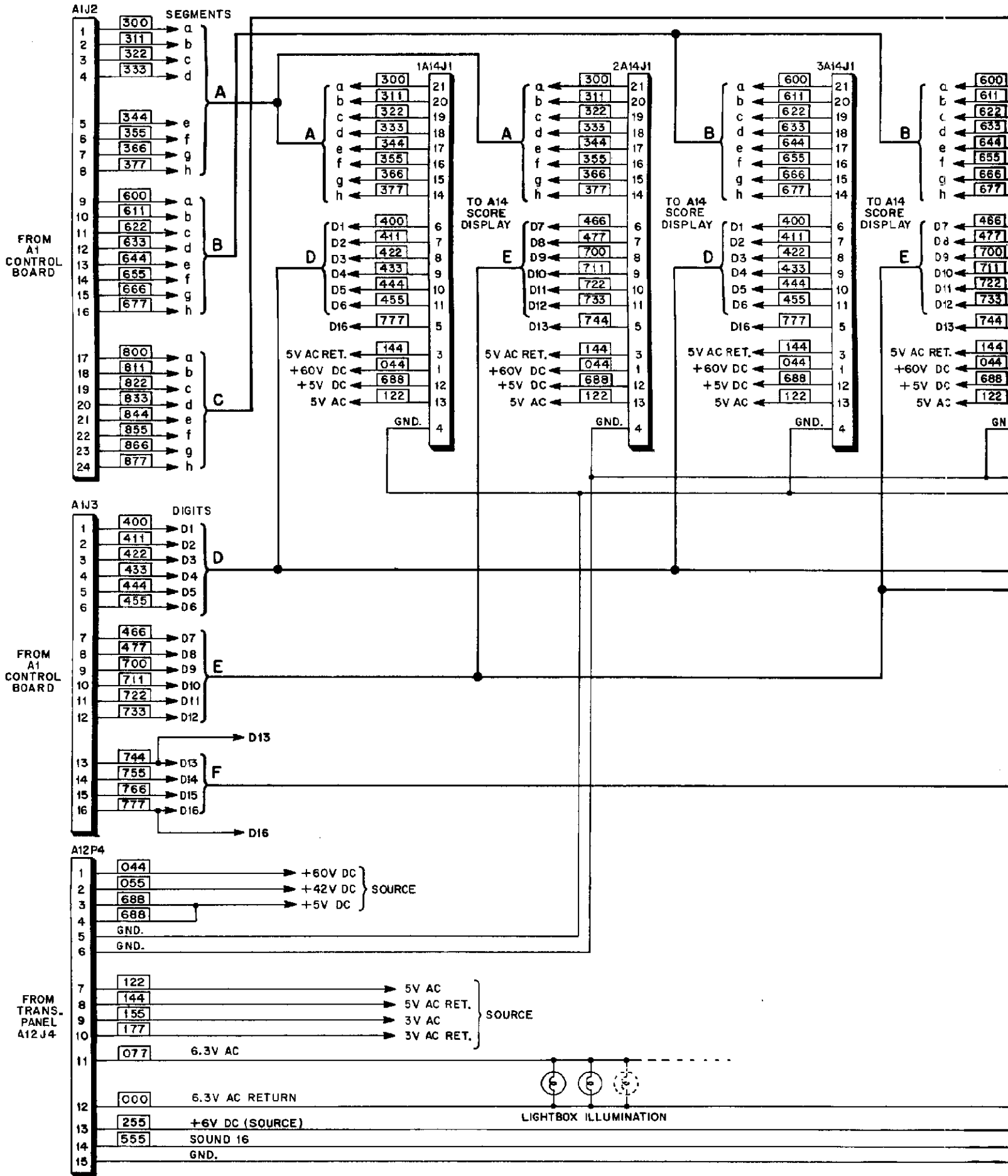

# WIRING DIAGRAMS, PARTS LISTS

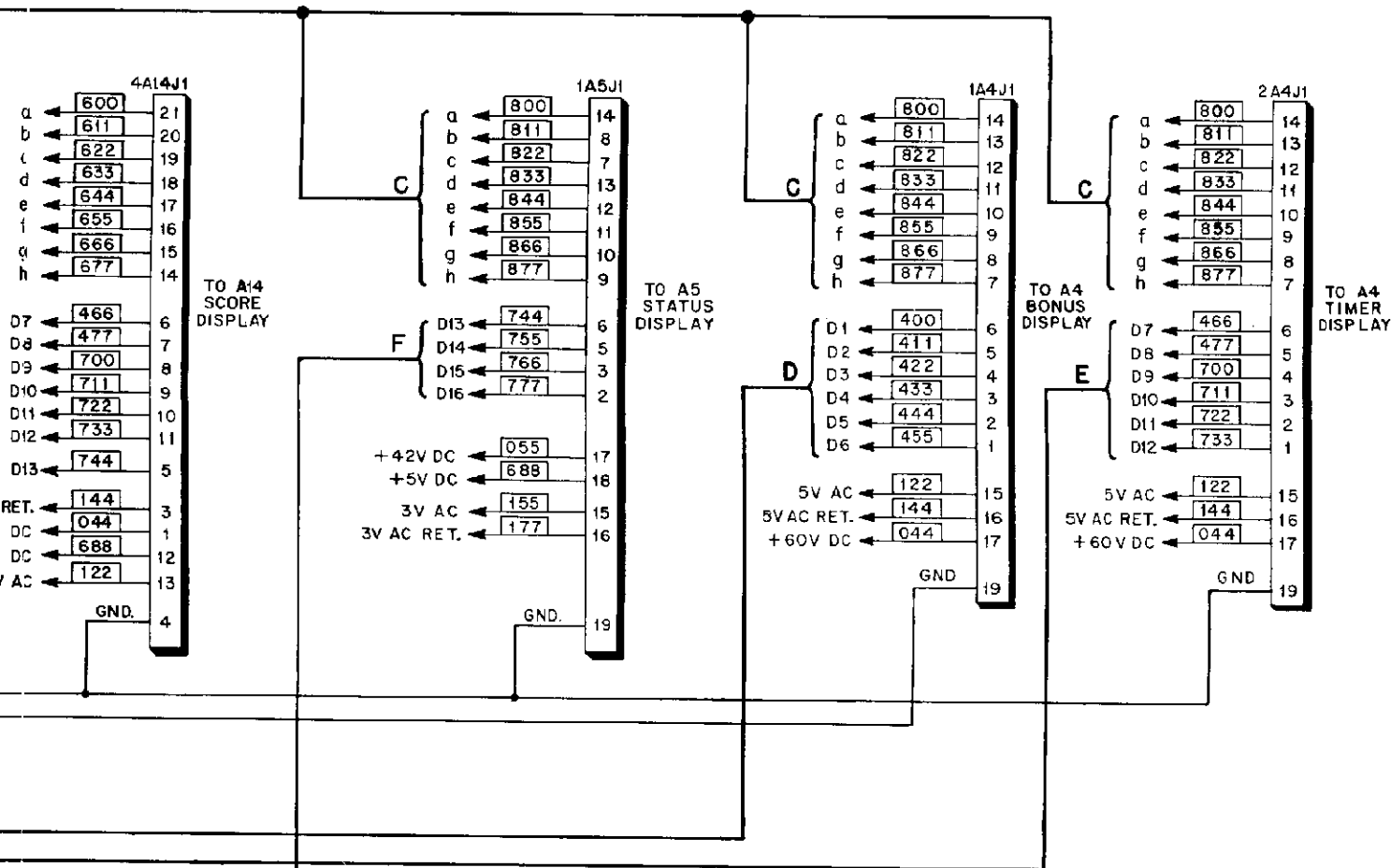

COLOR CODE			
0	BLACK	5	GREEN
1	BROWN	6	BLUE
2	RED	7	PURPLE
3	ORANGE	8	SLATE
4	YELLOW	9	WHITE

**NOTE:**

1. XXX INDICATES WIRE COLOR.
2. GROUND WIRE IS #54, 18GA.
3. NAME AND SCENE LAMPS ARE #44 OR #455 FLASHING.

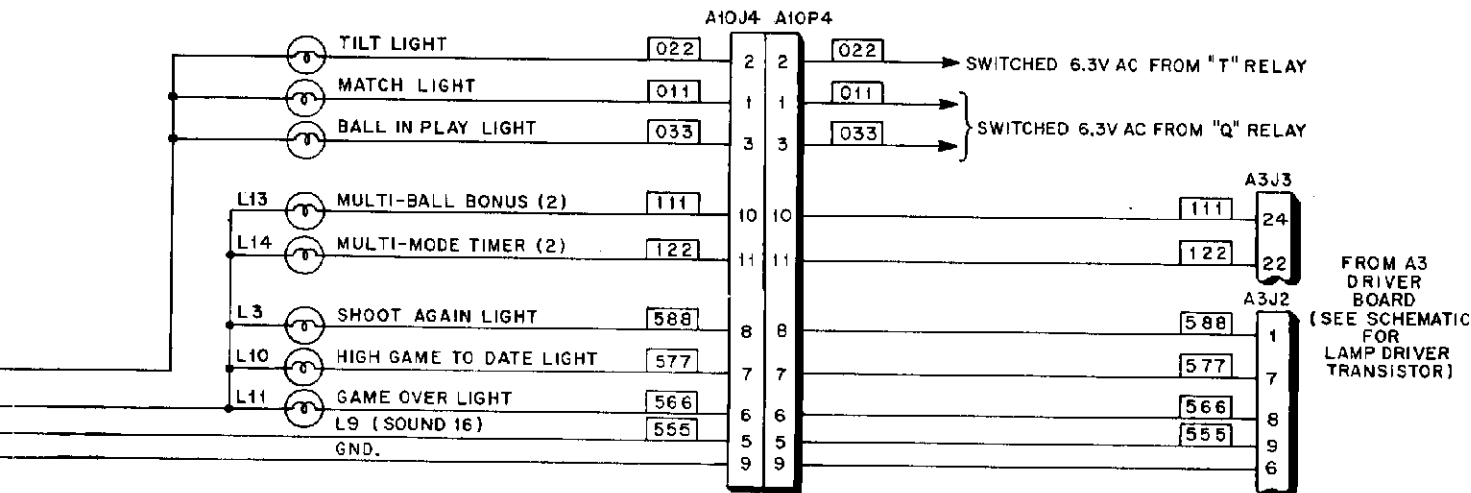
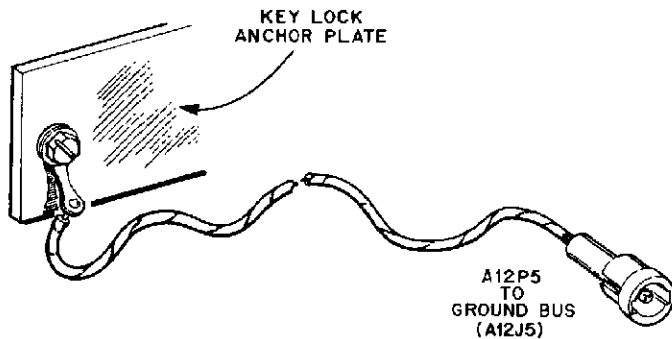

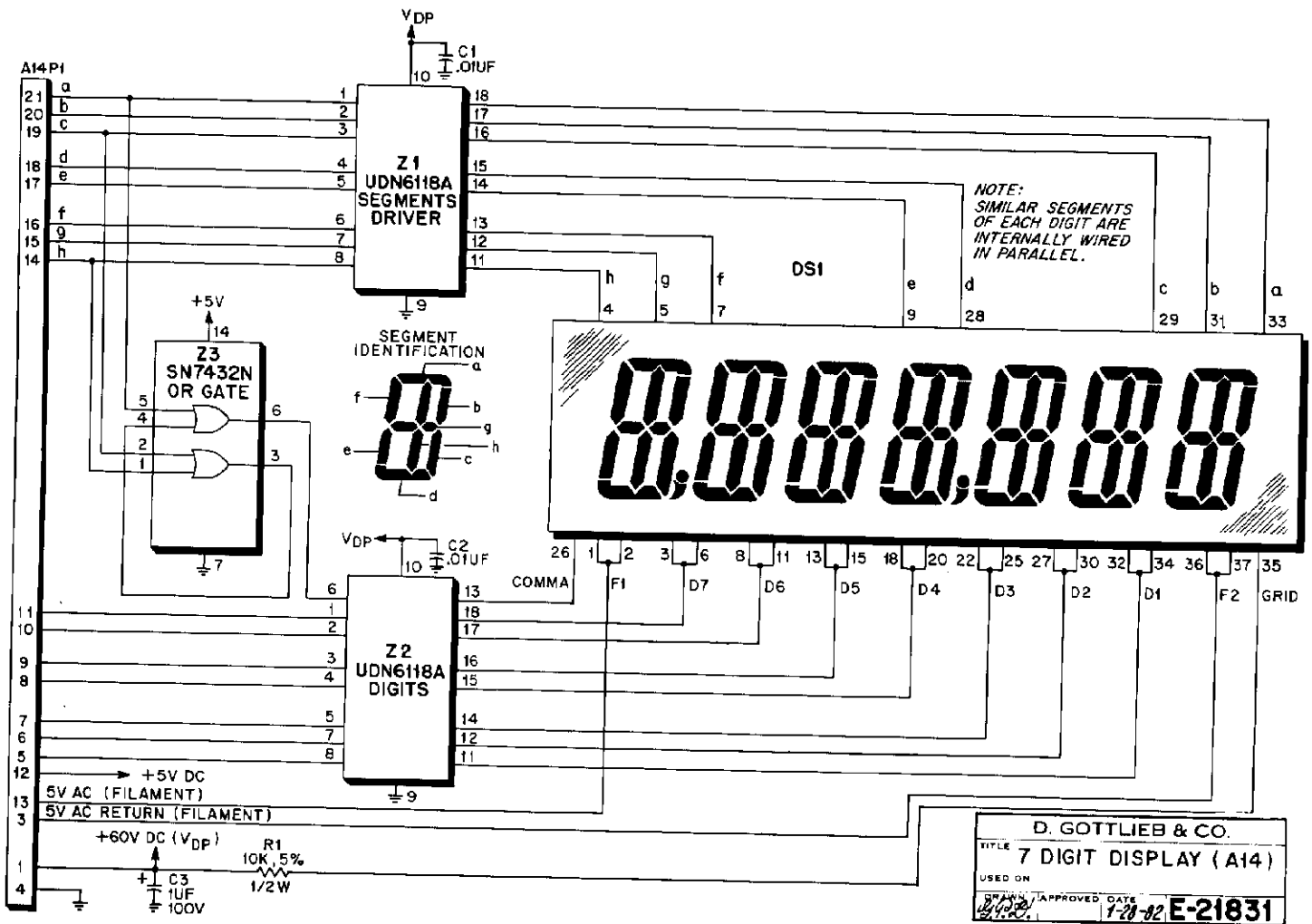

### 7-DIGIT DISPLAY (A14) COMPONENT LOCATION

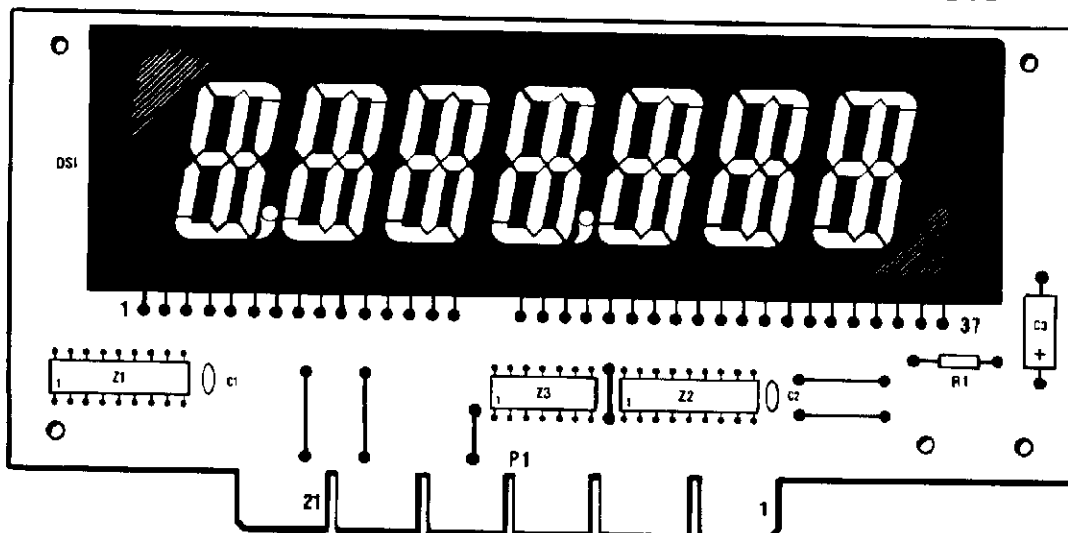

### 7-DIGIT DISPLAY (A14) PARTS LIST

REFERENCE	DESCRIPTION	PART NUMBER
C1, C2	Capacitor .01 mfd. 100V Kemet	X0-202
C3	Capacitor 1 mfd 100V Sprague	X0-206
DS1	7 Digit Display Tube - FUTABA	X0-477
R1	Resistor, 10K ohm, 5%, 1/2W	X0-62
Z1, Z2	IC - Fluorescent Display Driver - Sprague	X0-415
Z3	IC Quad or Gate	X0-407



# X. WIRING AND SCHEMATIC DIAGRAMS, PARTS LISTS

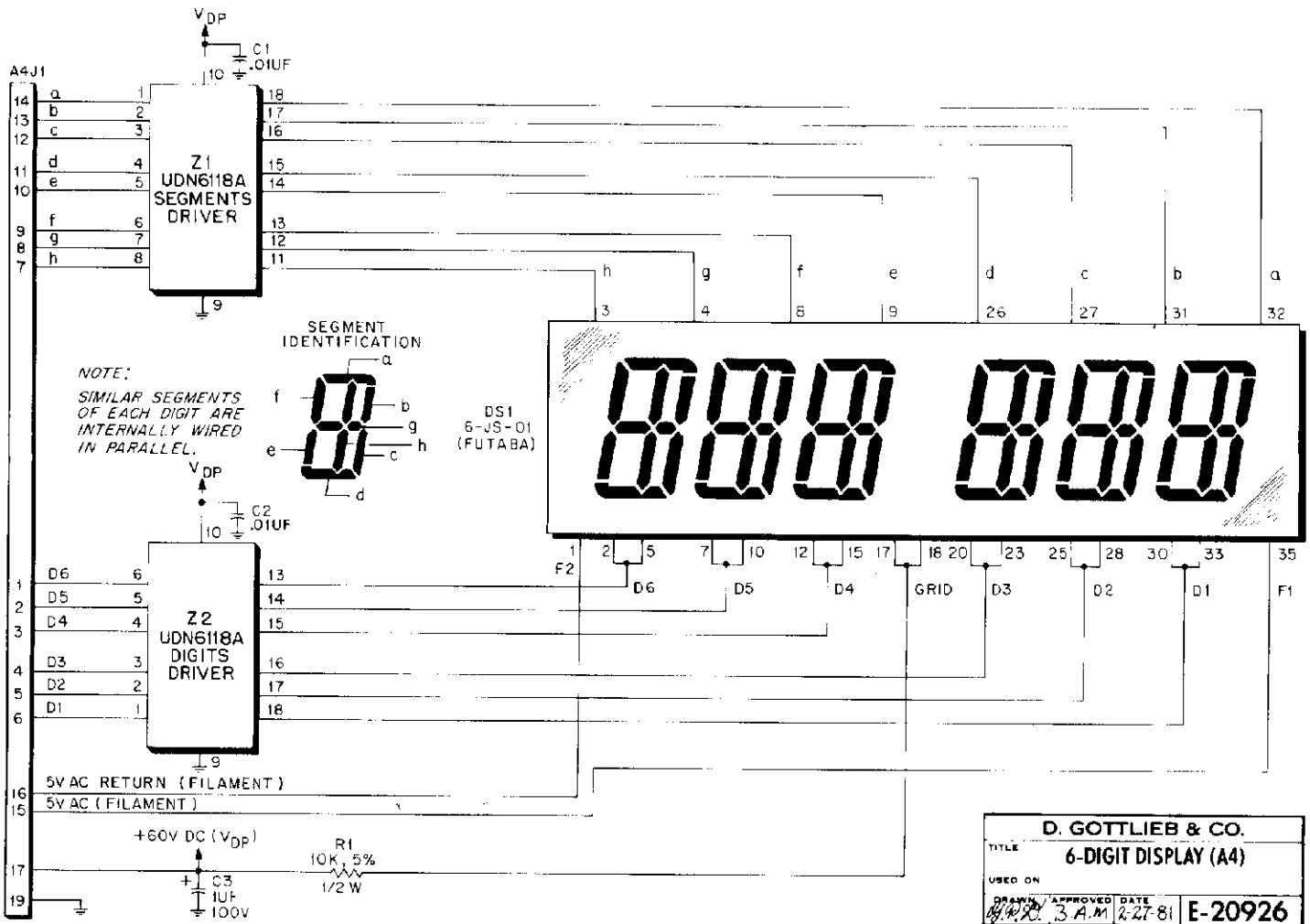

## 6-DIGIT DISPLAY (A4) COMPONENT LOCATION

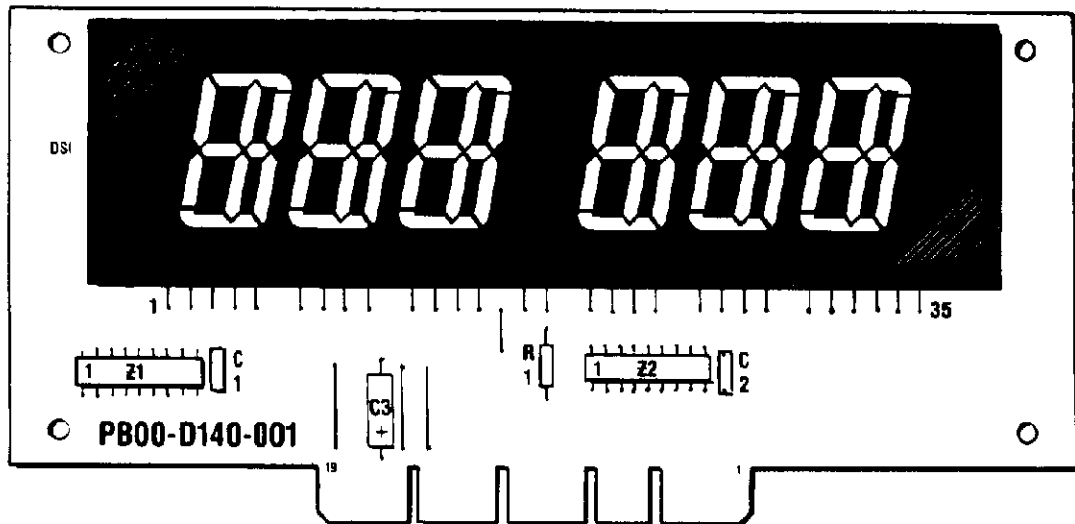

## 6-DIGIT DISPLAY (A4) PARTS LIST

REFERENCE	DESCRIPTION	PART NUMBER
C1, C2	Capacitor, .01 mfd., 100V Kemet	C320C103MIR5CA
C3	Capacitor, 1 mfd., 100V Sprague	TE1400
DS1	6-Digit Display Tube—FUTABA	6-JS-01
R1	Resistor, 10K ohm, 5%, 1/2W	RC20GF103
Z1, Z2	IC—Fluorescent Display Driver—Sprague	UDN6118A

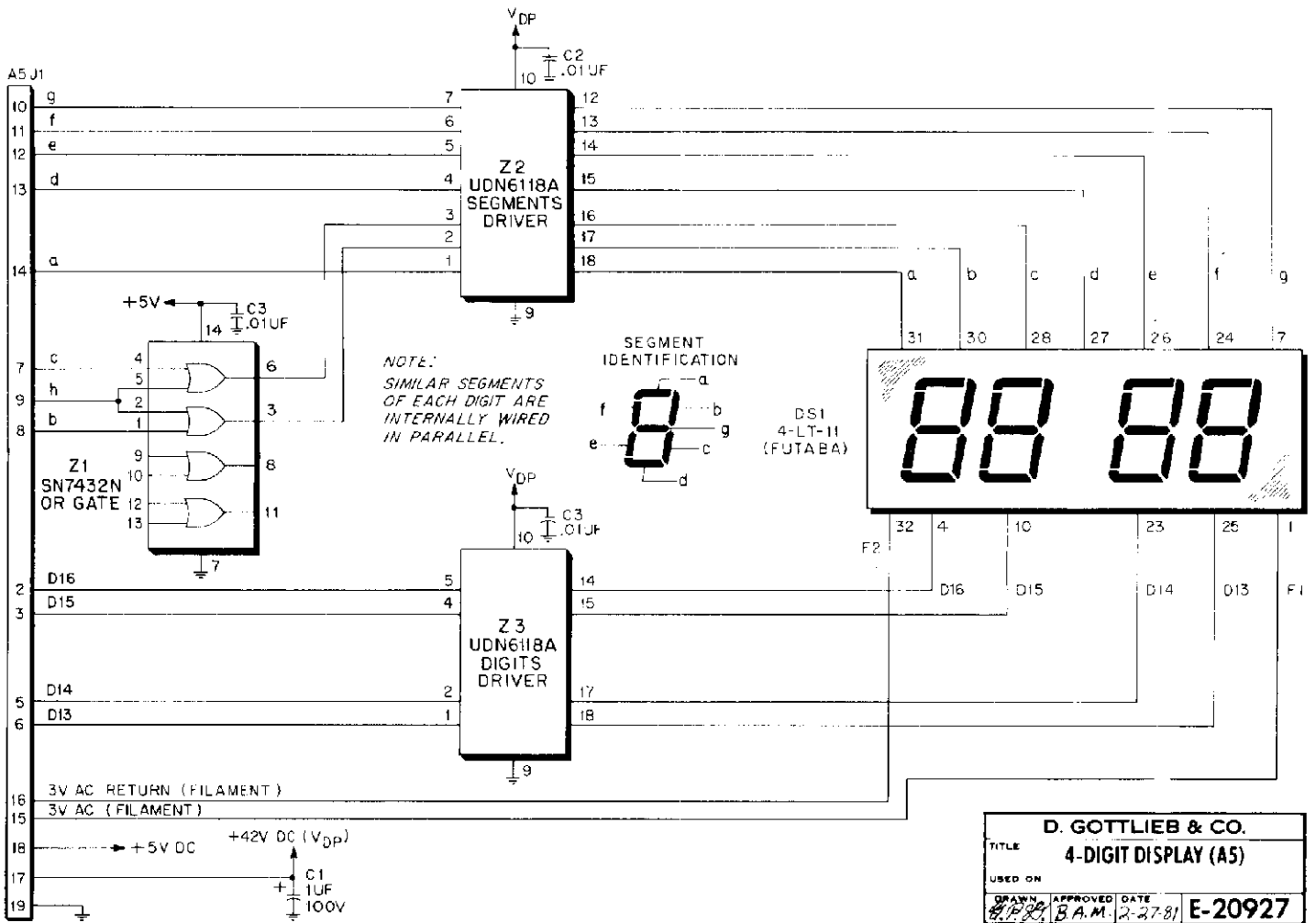

<b>D. GOTTLIEB &amp; CO.</b>			
TITLE <b>4-DIGIT DISPLAY (A5)</b>			
USED ON			
DRAWN B.P.P.	APPROVED B.A.M.	DATE 2-27-81	E-20927

### 4-DIGIT DISPLAY (A5) COMPONENT LOCATION

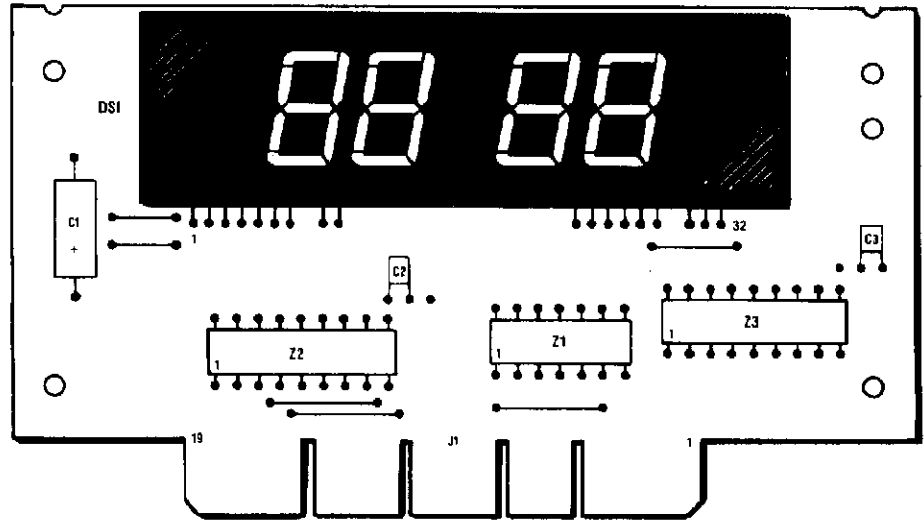

### 4-DIGIT DISPLAY (A5) PARTS LIST

REFERENCE	DESCRIPTION	PART NUMBER
C1	Capacitor, 1 mfd., 100V Sprague	TE1400
C2, C3	Capacitor, .01 mfd., 100V Kemet	C320C103MIR5CA
DS1	4-Digit Display Tube—FUTABA	4-LT-11
Z1	IC—Quad or Gate—T.I.	SN7432N
Z2, Z3	IC—Fluorescent Display Driver—Sprague	UDN6118A

# X. WIRING AND SCHEMATIC DIAGRAM

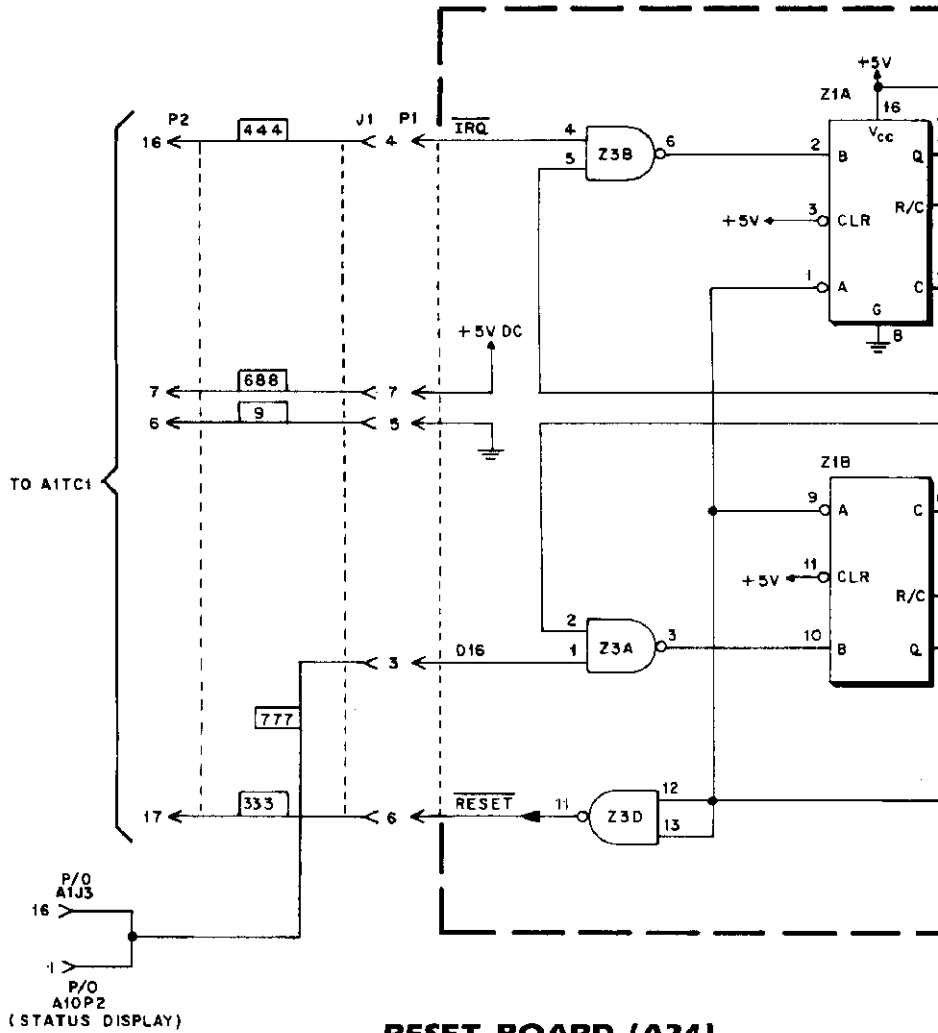

## RESET BOARD (A24) COMPONENT LOCATION

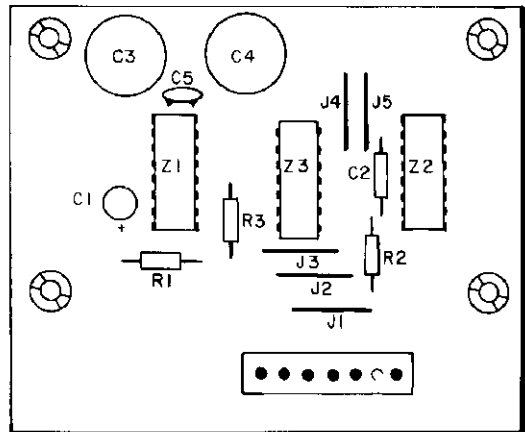

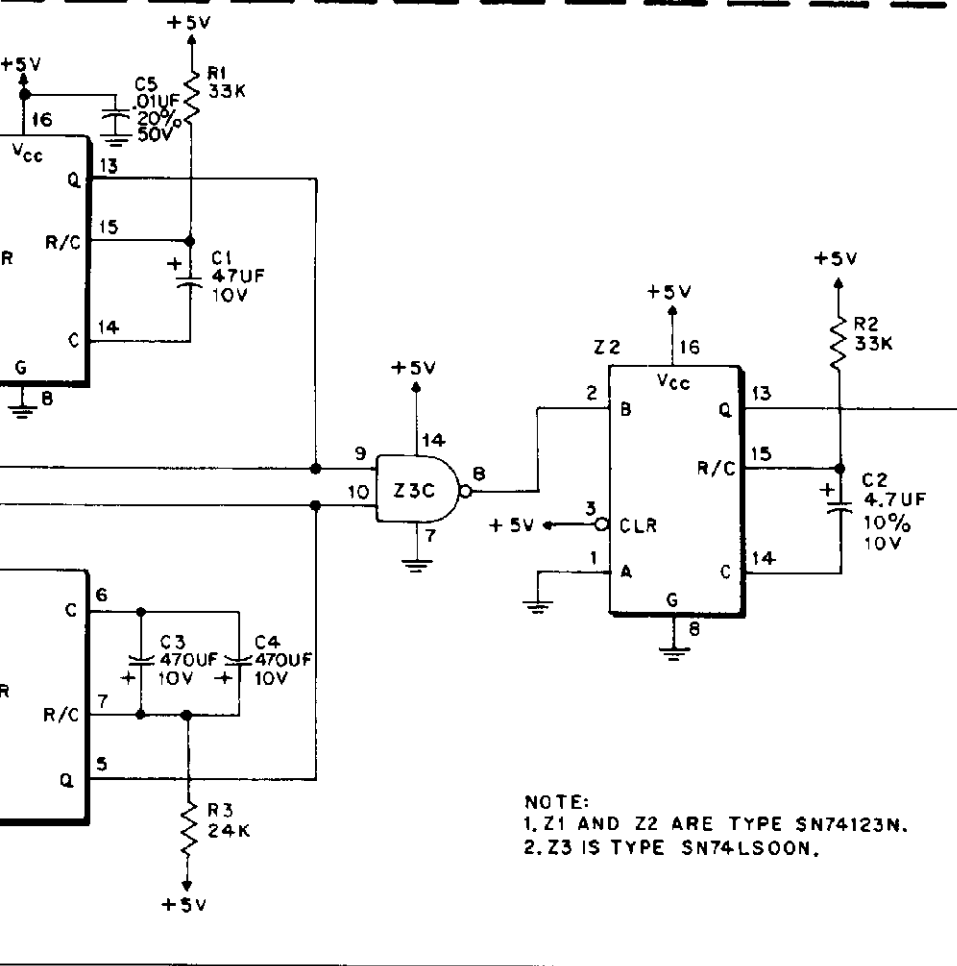

NOTE:  
 1. Z1 AND Z2 ARE TYPE SN74123N.  
 2. Z3 IS TYPE SN74LS00N.

<b>D. GOTTLIEB &amp; CO.</b>			
TITLE	RESET CIRCUIT BOARD		
USED ON			
DRAWN	APPROVED	DATE	<b>C-21063</b>
<i>[Signature]</i>	BAM	4-2-81	

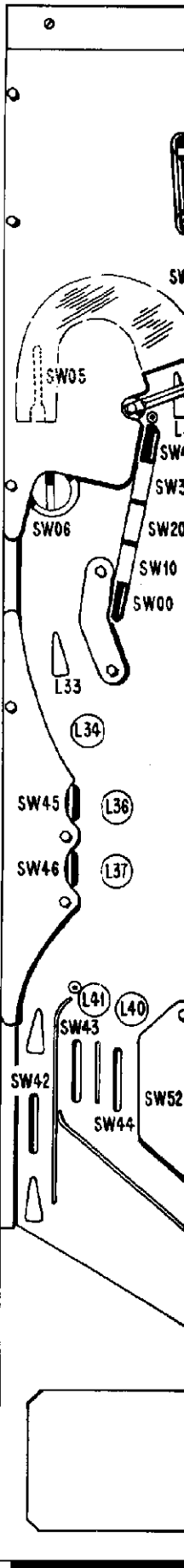

**RESET BOARD (AZ4) PARTS LIST**

REFERENCE	DESCRIPTION	PART NUMBER
R1, R2	Resistor 33K ohm, 5%, 1/4W.	XO-43
R3	Resistor 24K ohm, 5%, 1/4W.	XO-10
C1	Capacitor 4.7 µfd., 10V.	XO-227
C2	Capacitor 4.7 µfd., 10V.	XO-226
C3, C4	Capacitor 470 µfd., 16V.	XO-214
C5	Capacitor .01 µfd., 50V.	XO-229
Z1, Z2	IC 74123N	XO-398
Z3	IC 74LS00N	XO-427
	7 Pin Connector	XO-526

# X. WIRING AND SCHEMATIC DIAGRAMS, PARTS LISTS

## PLAYBOARD SWITCH AND LAMP ASSIGNMENTS

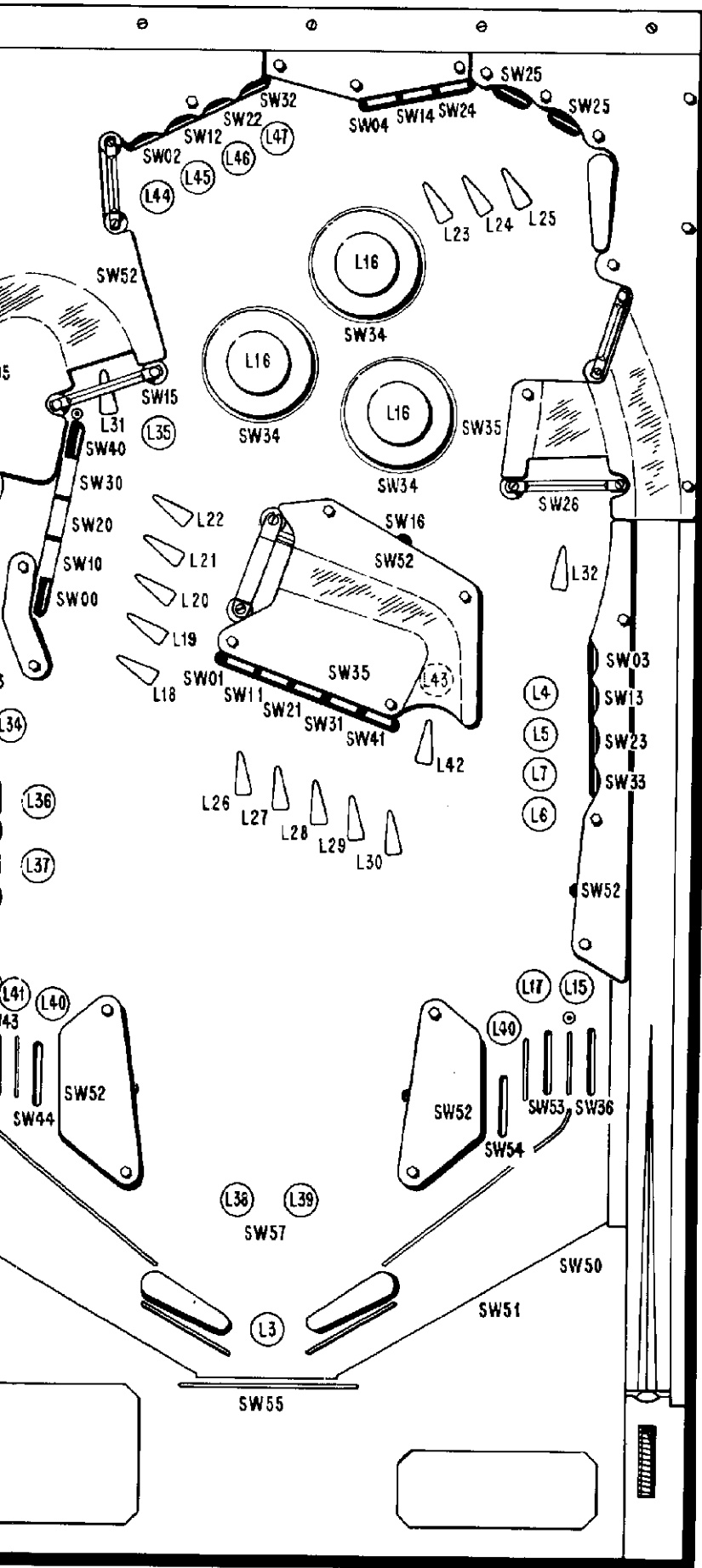

### SWITCH MATRIX

SWITCH NO.	SWITCH ASSIGNMENT	LAMP NO.	LAMP ASSIGNMENT
00	#1 Left Drop Target	L 3	Shoot Again
01	#1 Right Drop Target	L 4	#1 Right Bottom Target
02	#1 Left Top Target	L 5	#2 Right Bottom Target
03	#1 Right Bottom Target	L 6	#3 Right Bottom Target
04	#1 Top Drop Target	L 7	#4 Right Bottom Target
05	Top Ball Kicker	L 15	Right Outside Rollover
06	Hole	L 16	Pop Bumper (3)
10	#2 Left Drop Target	L 17	Right Outside Return Rollover
11	#2 Right Drop Target	L 18	#1 Left Drop Target
12	#2 Left Top Target	L 19	#2 Left Drop Target
13	#2 Right Bottom Target	L 20	#3 Left Drop Target
14	#2 Top Drop Target	L 21	#4 Left Drop Target
15	Left Spin Target	L 22	#5 Left Drop Target
16	Rollunder	L 23	#1 Top Drop Target
20	#3 Left Drop Target	L 24	#2 Top Drop Target
21	#3 Right Drop Target	L 25	#3 Top Drop Target
22	#3 Left Top Target	L 26	#1 Right Drop Target
23	#3 Right Bottom Target	L 27	#2 Right Drop Target
24	#3 Top Drop Target	L 28	#3 Right Drop Target
25	Right Top Target (2)	L 29	#4 Right Drop Target
26	Right Spin Target	L 30	#5 Right Drop Target
30	#4 Left Drop Target	L 31	Left Spin Target
31	#4 Right Drop Target	L 32	Right Spin Target
32	#4 Left Top Target	L 33	Hole (2 Ball Multi-Ball)
33	#4 Right Bottom Target	L 34	Hole Capture
34	Pop Bumpers (3)	L 35	Top Kicker Capture
35	Drop Target	L 36	Top Left Bottom Target
	Ten Point Switch	L 37	Bottom Left Bottom Target
36	Right Outside Rollover	L 38	2X
40	#5 Left Drop Target	L 39	3X
41	#5 Right Drop Target	L 40	Inside Return Rollovers(2)
42	Left Outside Rollover	L 41	Left Outside Return Rollover
43	Left Outside Return Rollover	L 42	Rollunder
44	Left Inside Return Rollover	L 43	Extra Ball
45	#2 Left Bottom Target	L 44	#1 Left Top Target
46	#1 Left Bottom Target	L 45	#2 Left Top Target
50	First Position Trough	L 46	#3 Left Top Target
51	Third Position Trough	L 47	#4 Left Top Target
52	Kicking Rubbers (5)		
53	Right Outside Return Rollover		
54	Right Inside Return Rollover		
55	Outhole		
57	Tilt		

# X. WIRING AND SCHEMATIC DIAGRAMS, PARTS LISTS

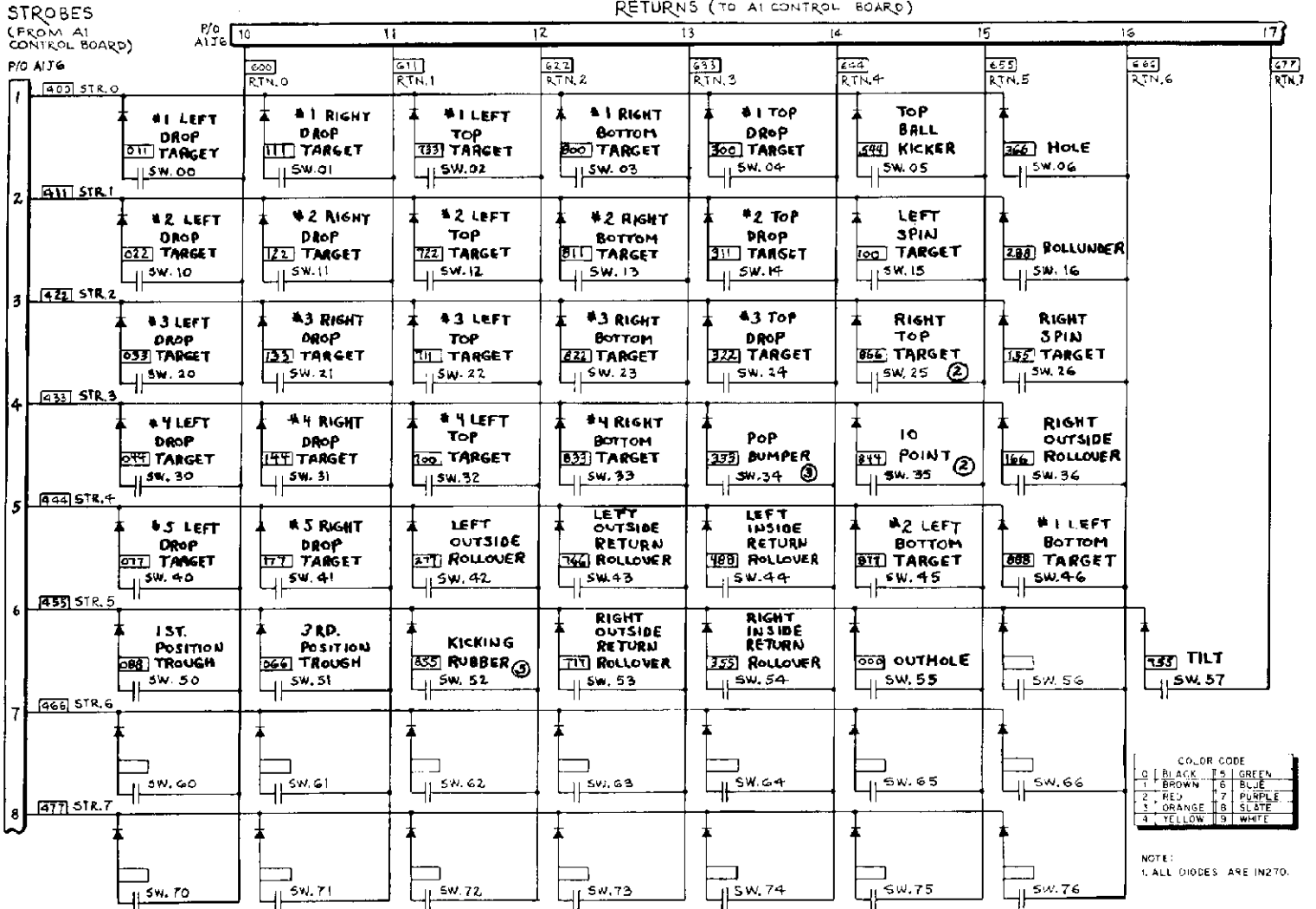

D. GOTTLIEB & CO.  
TITLE SWITCH MATRIX  
USED ON GAME # 670  
DRAWN BY [Signature] APPROVED DATE 2-8-62 E-21856

# X. WIRING AND SCHEMATIC D

## PLAYFIELD "CONTROLLED" SOLENOIDS AND ILLUMINATION

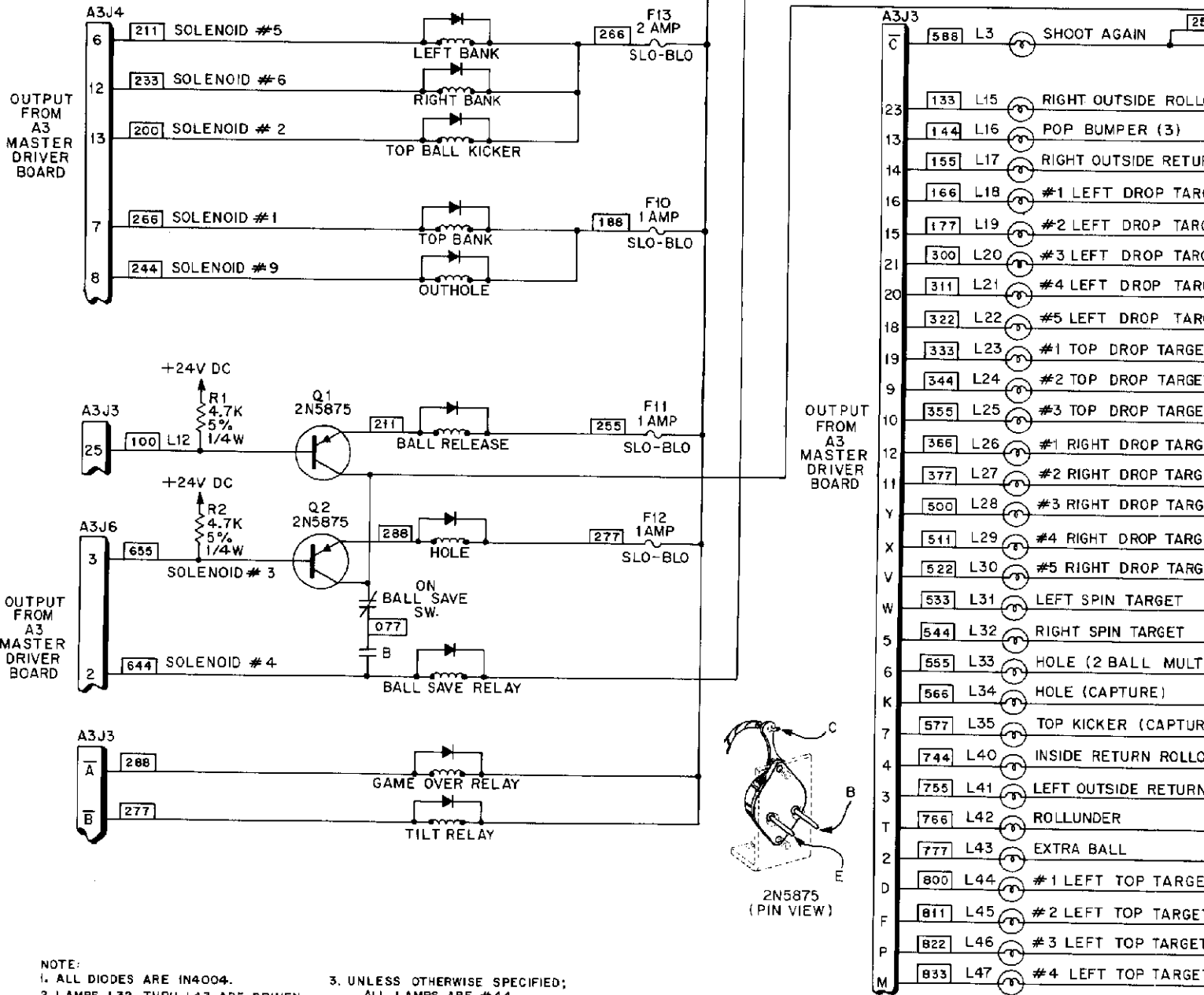

- NOTE:
- ALL DIODES ARE IN4004.
  - LAMPS L32 THRU L43 ARE DRIVEN BY MPS-A13'S; ALL OTHER LAMPS ARE DRIVEN BY MPS-U45'S.
  - UNLESS OTHERWISE SPECIFIED; ALL LAMPS ARE #44. GROUND WIRE COLOR IS 54, 186A.
  - [XXX] INDICATES WIRE COLOR.

COILS USED			
PART NO.	DESCRIPTION	PART NO.	DESCRIPTION
A-17891	LEFT BANK	A-1496	KICKING RUBBER (5)
A-17891	RIGHT BANK	A-17875	TOP FLIPPER
A-5194	TOP BALL KICKER	A-4893	BALL SAVER
A-18102	TOP BANK	A-20095	LEFT FLIPPER
A-16570	OUTHOLE	A-20095	RIGHT FLIPPER
A-16570	BALL RELEASE	A-1496	POP BUMPERS (3)
A-5195	HOLE		
A-16890	BALL SAVE RELAY		
A-16890	GAME OVER RELAY		
A-16890	TILT RELAY		

COLOR CODE	
0	BLACK
1	BROWN
2	RED
3	ORANGE
4	YELLOW
5	GREEN
6	BLUE
7	PURPLE
8	SLATE
9	WHITE

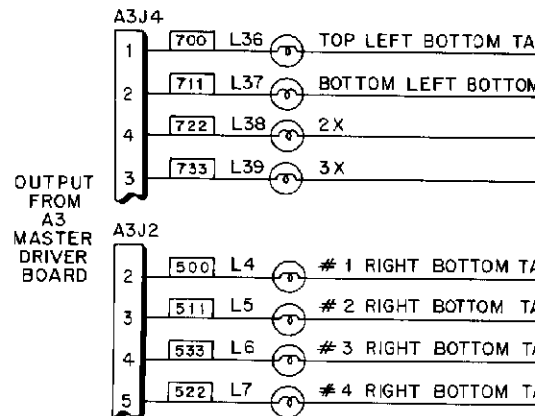

## PLAYFIELD "NON-CONTROLLED" SOLENOIDS AND ILLUMINATION

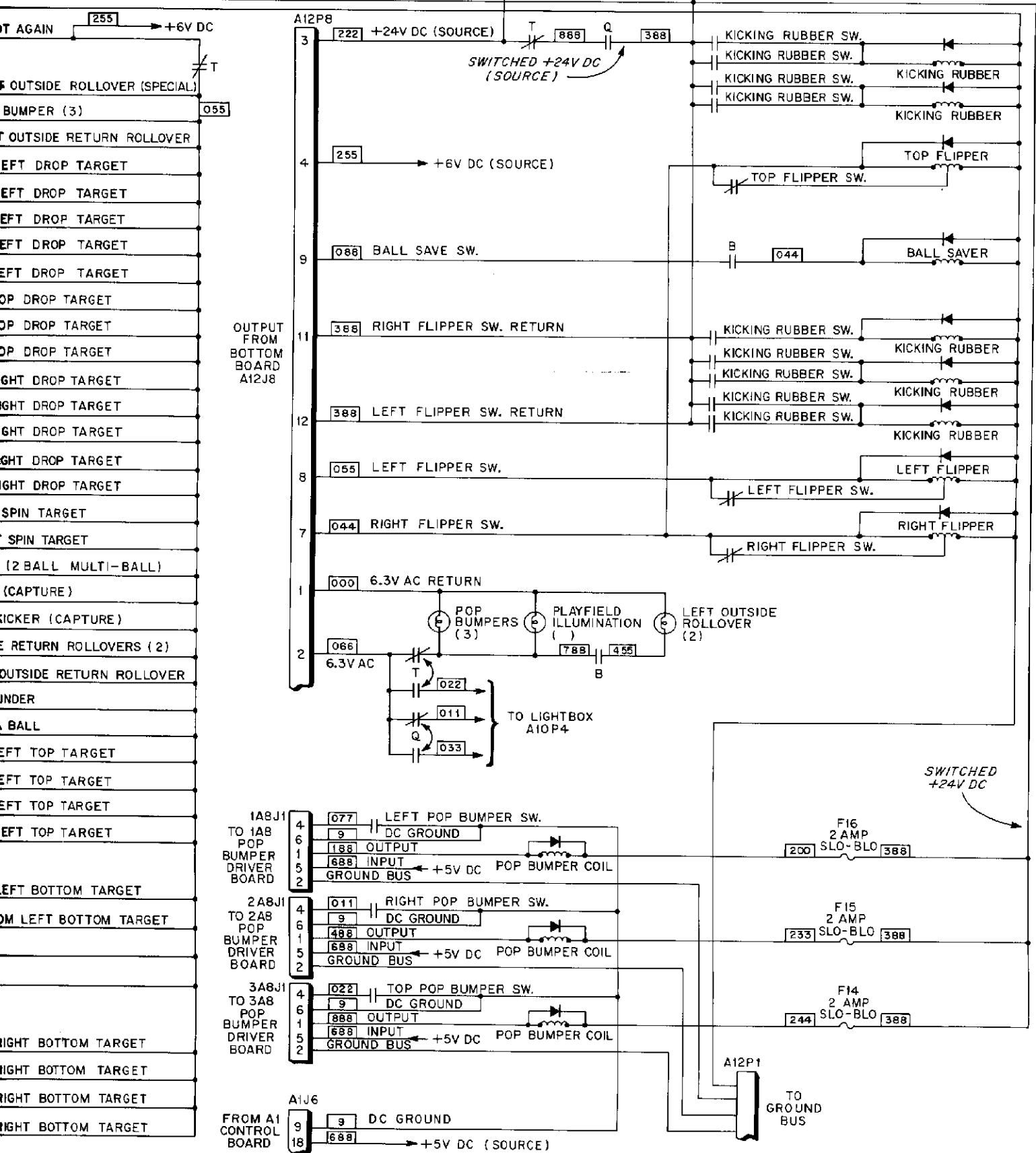

<b>D. GOTTLIEB &amp; CO.</b>	
FILE	PLAYFIELD
USED ON	SOLENOIDS AND ILLUMINATION
	GAME # 670
DRAWN	APPROVED DATE
R	2-8-62 E-21857



**POWER SUPPLY (A2) COMPONENT LOCATION**

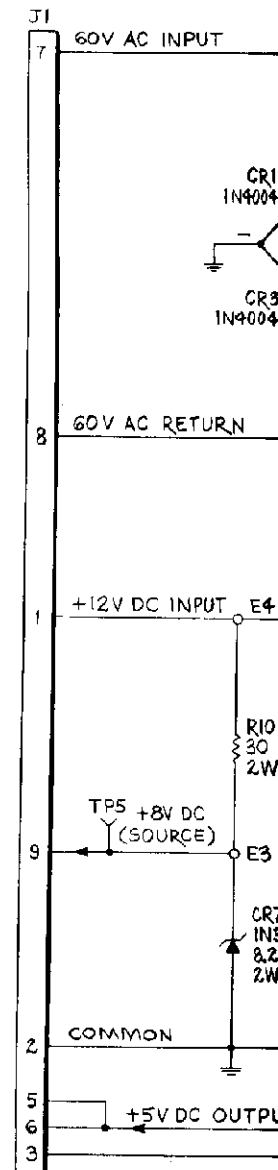
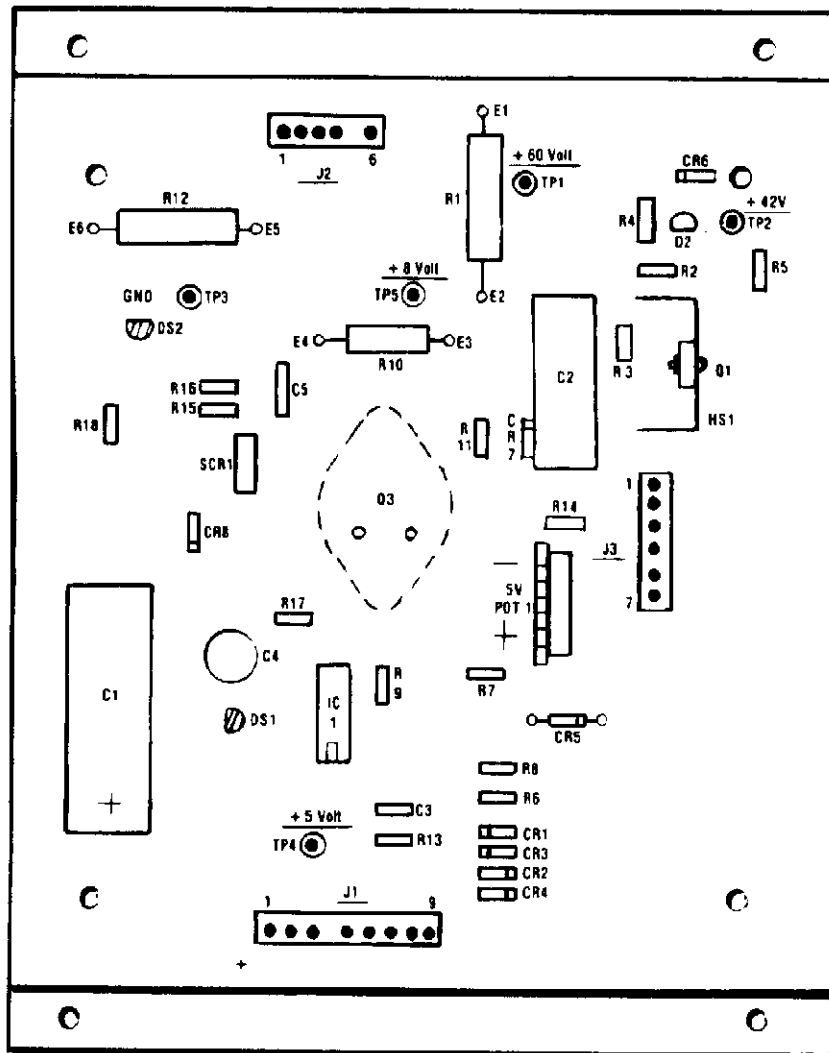

NOTE: UNLESS OTHERWISE SPECIFIED:  
 1. RESISTORS ARE 1/4W  
 2. VOLTAGES ARE DC  
 3. ALL VOLTAGES ARE TO GROUND

**POWER SUPPLY (A2) PARTS LIST**

REFERENCE	DESCRIPTION	PART NUMBER	REFERENCE	DESCRIPTION	PART NUMBER
C1	Capacitor, 470 mfd., 100V		R4	Resistor, 33 ohm, 5%, 1W	
C2	Capacitor, 47 mfd., 100V		R5	Resistor, 10K ohm, 5%, 1/2W	
C3	Capacitor, 1000 Picofarad, 50V		R6, R13	Resistor, 510 ohm, 5%, 1/4W	
C4	Capacitor, 470 mfd., 10V		R7	Resistor, 3.9K ohm, 5%, 1/4W	
C5	Capacitor, 2 mfd., +80%, -20%, 16V		R8	Resistor, 10K ohm, 5%, 1/4W	
CR1-CR4	Diode	1N4004	R10	Resistor, 30 ohm, 5%, 2W	
CR5	Diode, Zener, 62V, 5%, 1W	1N4759A	R11	Resistor, 2.2K ohm, 5%, 1/4W	
CR6	Diode, Zener, 18V, 5%, 1W	1N4746A	R12	Resistor, 33 ohm, 10%, 5W (Wirewound)	
CR7	Diode, Zener, 8.2V, 10%, 2W	1N3445	R14	Resistor, 2K ohm, 5%, 1/4W	
CR8	Diode, Zener, 5.6V, 5%, 1W	1N4734A	R15	Resistor, 100 ohm, 5%, 1/4W	
DS1, DS2	Diode, Light Emitting	CM4-22	R16	Resistor, 20 ohm, 5%, 1/4W	
E1-E6	Turret Terminal		R17	Resistor, 620 ohm, 5%, 1/2W	
IC1	I.C.—14 Pin Dip	UA723CN	R18	Resistor, 180 ohm, 5%, 1/4W	
J1	Connector, 9 Pin, Molex		SCR1	Silicon Controlled Rectifier	S107Y1
J2	Connector, 6 Pin, Molex		TP1-TP5,	Turret Terminal	
J3	Connector, 7 Pin, Molex			Eyelet	GS2-3
POT1	Potentiometer, 500 ohm, CTS	115R501A		Heat Sink Mounting Plate	
Q1	Transistor, NPN, National	SW4F013		Heat Sink, Thermalloy	
Q2	Transistor, NPN	2N5550		Insulator	INS-3
Q3	Transistor, Darlington, LAMBDA	PMD10K40		Insulator	DMI11
R1	Resistor, 1.3K ohm, 10%, 5W			Spacer—6-32 Thread x 5/32	
R2, R9	Resistor, 1K ohm, 5%, 1/4W			Spacer—6-32 Thread x 1/8	
R3	Resistor, 12K ohm, 5%, 1/2W				

# C DIAGRAMS, PARTS LISTS

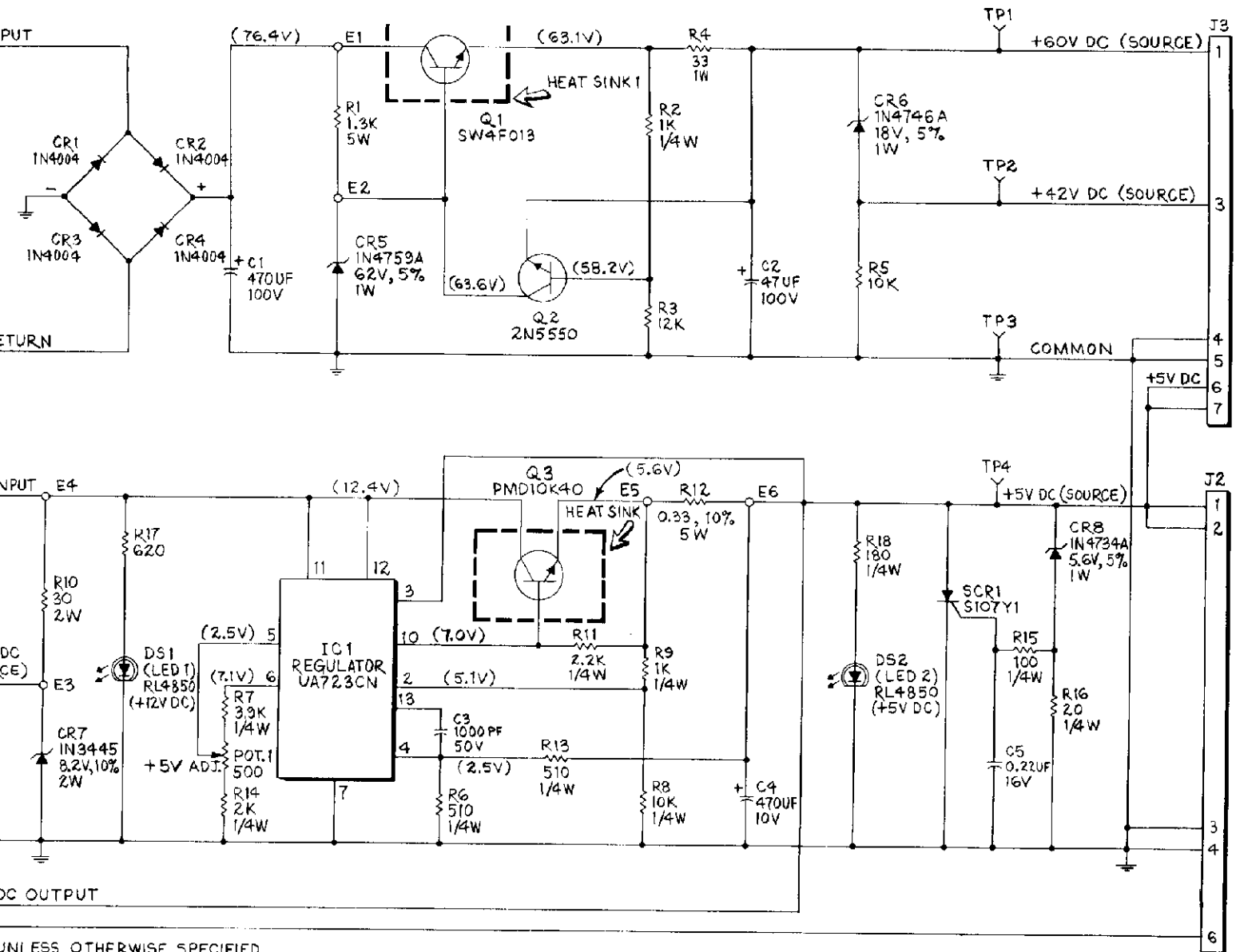

<b>D. GOTTLIEB &amp; CO.</b>			
TITLE		<b>POWER SUPPLY (A2)</b>	
USED ON			
DRAWN	APPROVED	DATE	<b>E-20922</b>
<i>B.P.R.</i>	<i>B.A.M.</i>	<i>2-3-81</i>	

# X. WIRING AND SCHEMATIC DIAGRAMS, PARTS LISTS

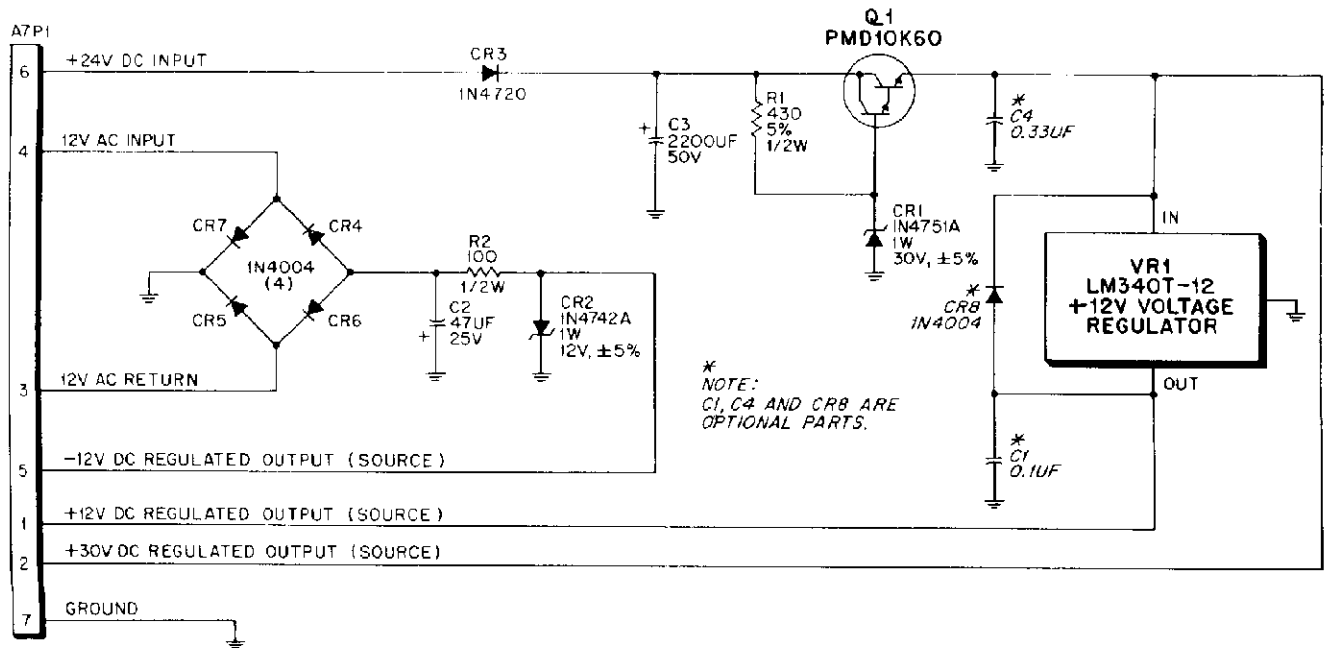

D. GOTTLIEB & CO.			
TITLE	SOUND/SPEECH BOARD POWER SUPPLY A7		
USED ON			
DESIGNED BY	APPROVED	DATE	D-21343
		8-5-81	

## SOUND/SPEECH POWER SUPPLY (A7) COMPONENT LOCATION

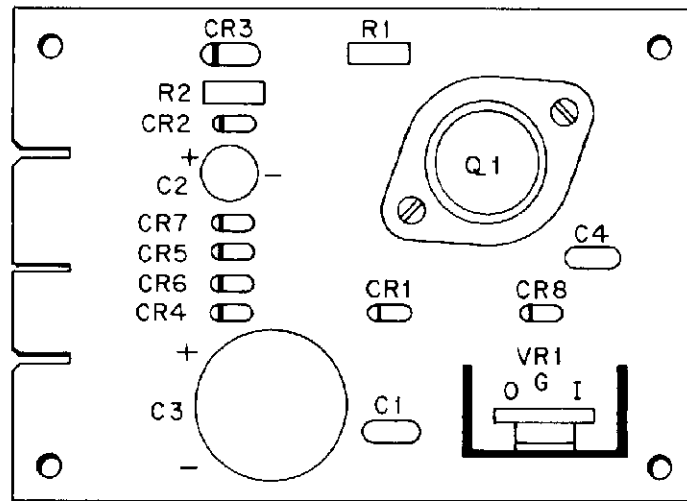

## SOUND/SPEECH POWER SUPPLY (A7) PARTS LIST

REFERENCE	DESCRIPTION	PART NO.
C1	Capacitor 0.1 UF	
C2	Capacitor 47 UF, 25 Volt	
C3	Capacitor 2200 UF, 50 Volt	
C4	Capacitor 0.33 UF	
CR1	Diode, Zener 30 V, ± 5%, 1W	IN4751A
CR2	Diode, Zener 12V, ± 5%, 1W	IN4742A
CR3	Diode	IN4720
CR4, CR5, CR6, CR7, CR8	Diode	IN4004
R1	Resistor 430 OHM, 5%, 1/2 Watt	
R2	Resistor 100 OHM, 1/2 Watt	
Q1	Transistor, Darlington Pair	PMD 10K60
VR1	+ 12 Volt Voltage Regulator	LM 340T-12

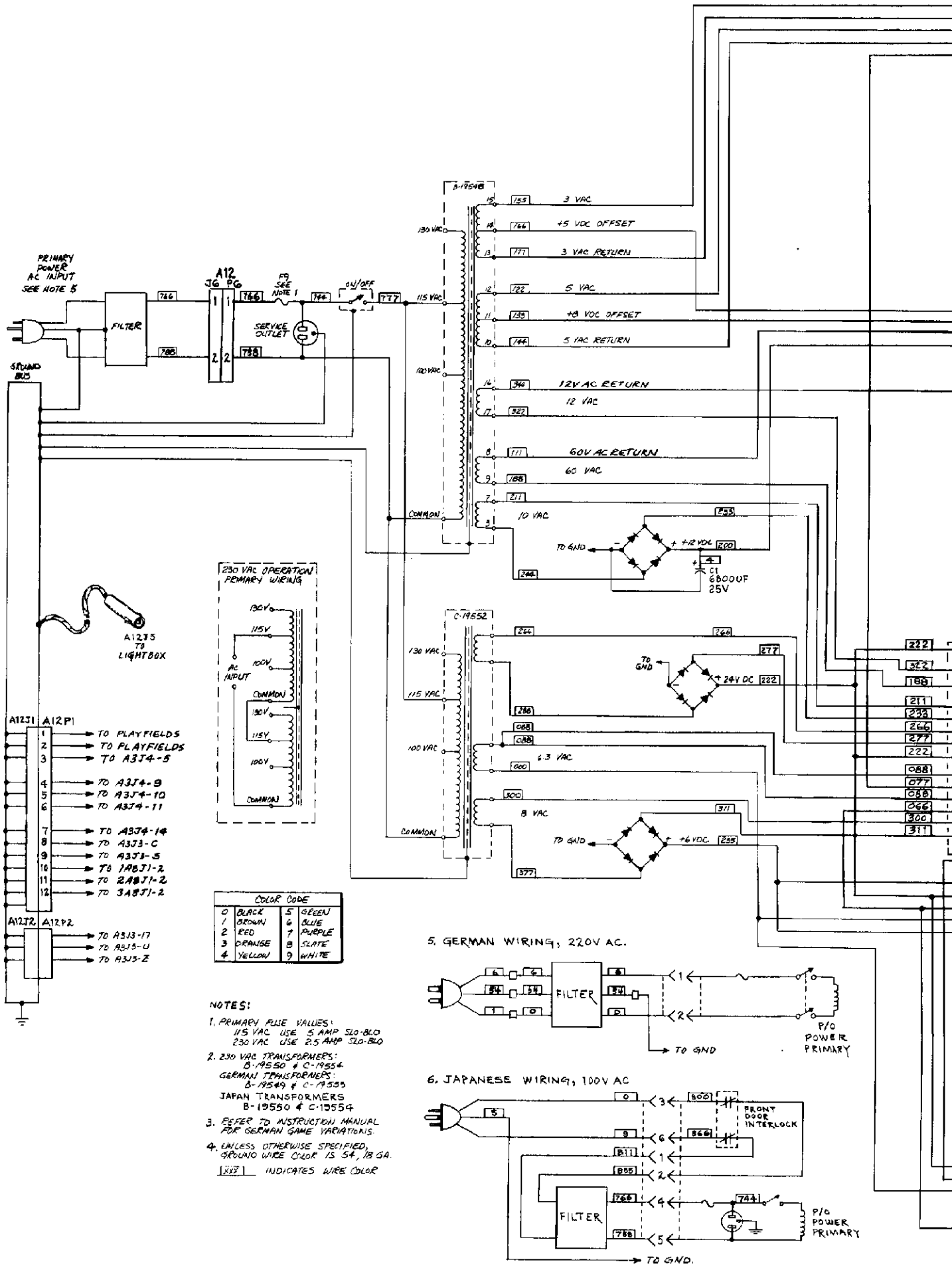

PRIMARY  
POWER  
AC INPUT  
SEE NOTE 5

GROUND  
BUS

230 VAC OPERATION  
PRIMARY WIRING

COLOR CODE	
0 BLACK	5 GREEN
1 BROWN	6 BLUE
2 RED	7 PURPLE
3 ORANGE	8 SLATE
4 YELLOW	9 WHITE

- NOTES:
1. PRIMARY FUSE VALUES:  
115 VAC USE 5 AMP SLO-BLO  
230 VAC USE 2.5 AMP SLO-BLO
  2. 230 VAC TRANSFORMERS:  
B-19550 & C-19554  
GERMAN TRANSFORMERS:  
B-19549 & C-19553  
JAPAN TRANSFORMERS  
B-19550 & C-19554
  3. REFER TO INSTRUCTION MANUAL  
FOR GERMAN GAME VARIATIONS.
  4. UNLESS OTHERWISE SPECIFIED,  
GROUND WIRE COLOR IS 54, 18 GA.  
[888] INDICATES WIRE COLOR

5. GERMAN WIRING, 220V AC.

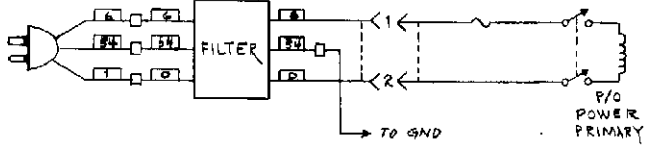

6. JAPANESE WIRING, 100V AC

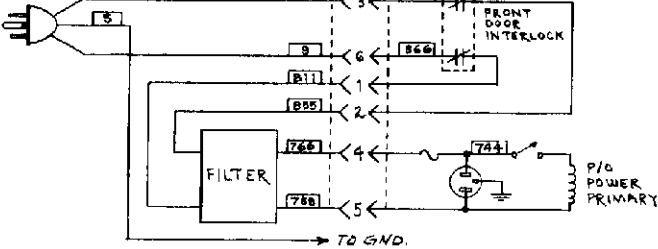

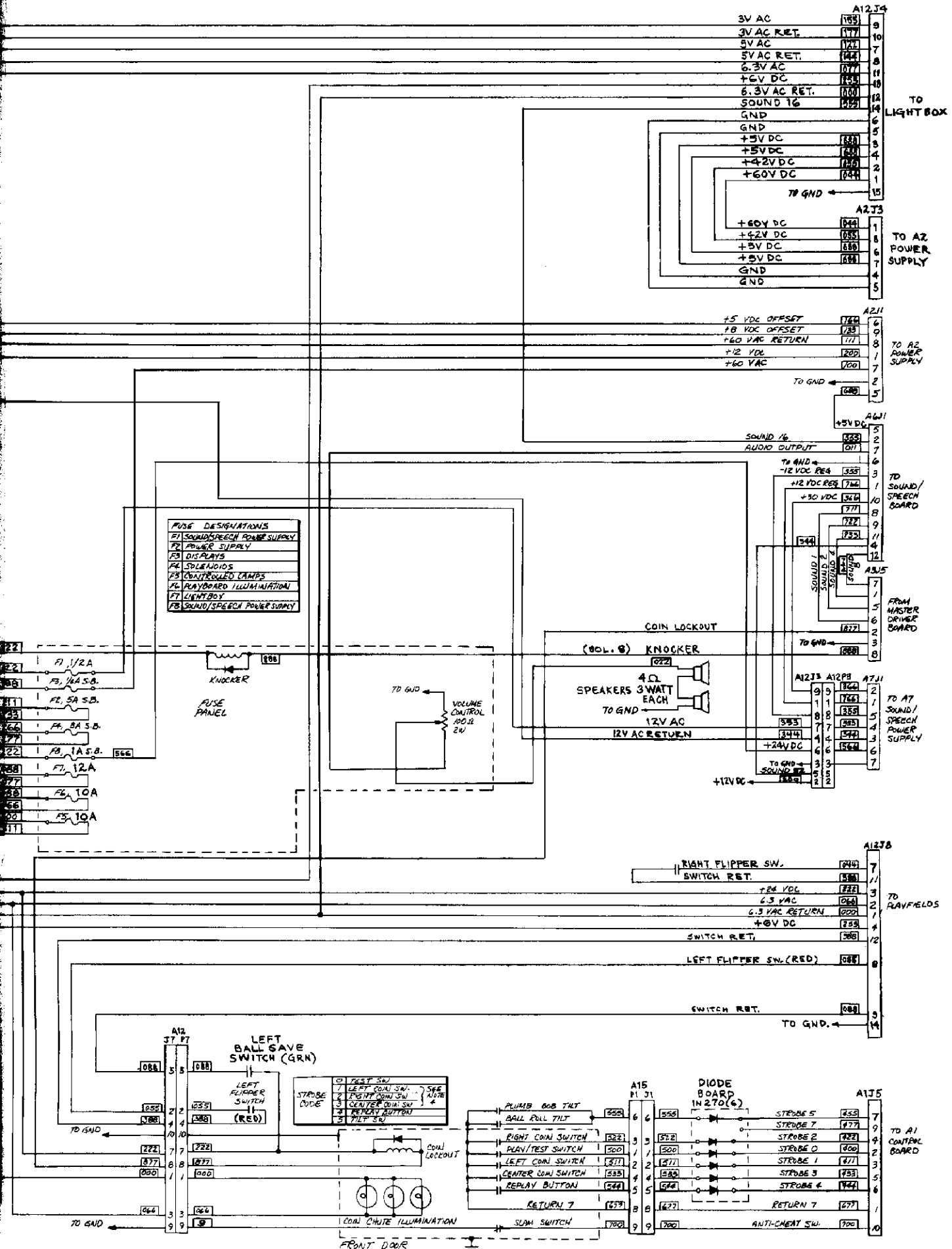

**FUSE DESIGNATIONS**

F1	SOUND/SPEECH POWER SUPPLY
F2	POWER SUPPLY
F3	DISPLAYS
F4	SOLENOIDS
F5	CONTROLLED LAMPS
F6	PLAYBOARD ILLUMINATION
F7	LIGHT BOY
F8	SOUND/SPEECH POWER SUPPLY

**D. GOTTLIEB & CO.**

TITLE: **BOTTOM BOARD AND CABINET GAME # 670**

USED ON: \_\_\_\_\_

DRAWN: **R** APPROVED: \_\_\_\_\_ DATE: **2-8-62** **E-21858**

# SERVICE NOTES

# XI. PARTS INFORMATION

## TABLE OF CONTENTS

<b>CABINET PARTS</b> .....	<b>49</b>
<b>PLAYBOARD PARTS</b> .....	<b>50</b>
<b>PLAYBOARD SWITCH MATRIX PARTS/ LAMP ASSIGNMENTS</b> .....	<b>51</b>
<b>PLAYBOARD (UNDERSIDE) COMPONENTS</b> .....	<b>52</b>
<b>PLAYBOARD ASSEMBLIES</b> .....	<b>53</b>
<b>LIGHTBOX PARTS</b> .....	<b>54</b>

# XI. PARTS INFORMATION

## CABINET PARTS

ITEM	DESCRIPTION	PART NO.
1.	Cabinet	Specify Game
2.	Hold Down Angle Bracket	B-19587
3.	Lightbox Mounting Bracket (4)	A-19916
4.	Line Cord Housing	C-18534
5.	Speakers 4 Ohm (2)	EL-83
6.	Right Playboard Support	D-19932
7.	Playboard Prop	D-19604
8.	Stop Bracket	A-5024
9.	Front Rest Saddle	A-11345
10.	Knocker Board Assy.	MA-261
	Knocker	MA-12
	Pot and Mounting Bracket	MA-185
	F1, 1/2 Amp Fuse	EL-28
	F2, 5 Amp SLO-BLO Fuse	EL-8
	F3, 1/4 Amp SLO-BLO Fuse	EL-5
	F4, 8 Amp SLO-BLO Fuse	EL-26
	F5 & 6, 10 Amp Fuse	EL-23
	F7, 12 Amp SLO-BLO Fuse	EL-24
	F8, 1 Amp SLO-BLO Fuse	EL-6
11.	Flipper Switch Assy.	B-17838
12.	Ball Shooter	B-8835
13.	Fuse Assy.	MA-186
14.	Switch	A-15401
	Switch Housing	A-15163
15.	Convenience Outlet	MA-17
16.	Front Door Assy.	Specify Game
17.	Ball Roll Tilt	MA-13
18.	A-21028	
19.	Left Playboard Support	D-19931
20.	Cabinet Leg (4)	D-4337
	3" Leg Adjuster	MH-21
21.	Transformer Board Assy.	MA-266
	Bridge Rectifier	EL-42
	Capacitor, 6800 mf, 25 Volt	XO-228
22.	Line Filter	EL-50

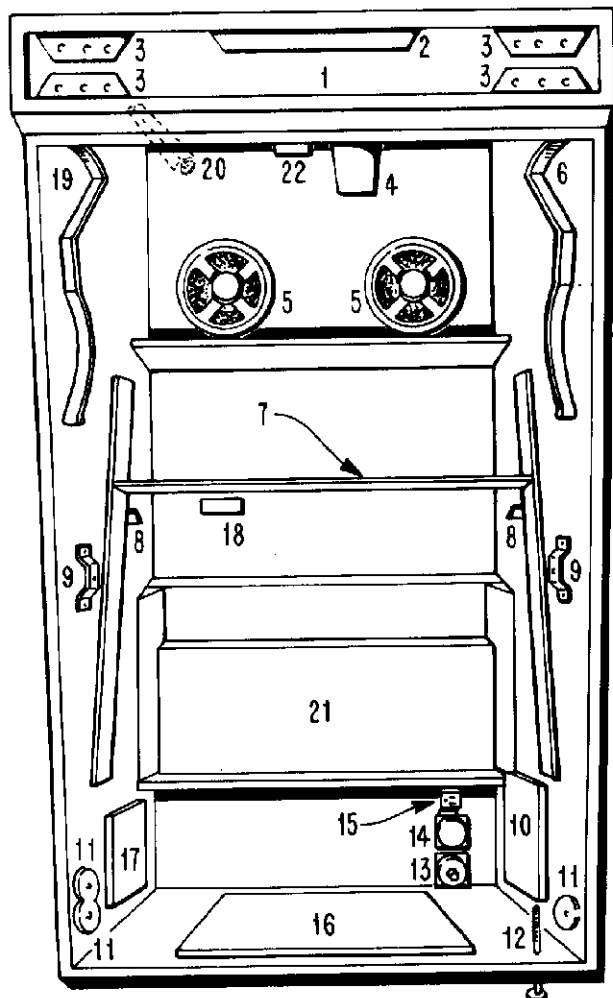



# XI. PARTS INFORMATION

## PLAYBOARD PARTS

### RUBBER RINGS

A	A-102 17	5/16"	(10)
B	A-102 18	3/4"	(2)
C	A-102 19	1"	(1)
D	A-10220	1½"	(1)
E	A-1022 1	2"	(1)
F	A-10222	2½"	(3)
G	A-10223	3"	(2)
H	A-10224	4"	(1)
I	A-13 15 1	1-13/16"	(3)
J	A-15705	7/16"	(5)

### PARTS LIST

1. B-2 1377 Metal Flat Rail
2. A-17300 Shield (2)
3. A-17650 Ball Guide Rail (2)
4. A-66 12 Ball Guide Rail (6)
5. A-13 150 White Flipper (3)
6. A-3722 Ball Guide Rail
7. A-2 1392 Pop Bumper Cap (3)
8. B-8246 Pop Bumper Trim Platter (3)
9. C-10433 Pop Bumper Skirt (3) and A-13905 Pop Bumper Body (3)
10. B-2 1378 Metal Flat Rail
11. A-14487 Split Post Base - White (6) and A-14488 Split Post Cap - White (6)
12. A-9374U Target Red (8)
13. A-9374T Target Yellow (4)
14. A-4832 Ball Guide Rail
15. B-2 1374 Metal Flat Rail
16. A-14043 Target Mounting Bracket (2) and A-20388 Target
17. A-14792 Mini Post Screw (9)
18. A-18070 Ball Guide Rail
19. A-2 1532 Ball Snubber
20. B-2 1375 Metal Flat Rail
21. A-4869 Gate Shield
22. A-483 1 Ball Guide Rail
23. A-17 106 Ball Guide Rail
24. B-2 1540 Ball Guide Rail
25. A-13798 Ball Snubber
26. B-20029 Ball Guide Rail
27. A-13584 Ball Guide Rail
28. A-2 1535 Ball Guide Rail
29. B-2 10 15 Metal Flat Rail
30. A-693 1 Ball Guide Rail
31. D-21004 Card Holder
32. A-2 1396 5 Position Drop Target Black Stamped in Red
33. A-2 1396 3 Position Drop Target Red Stamped in Black
34. A-2 1397 (3 large) Black Stamped in Red and A-2 1396 (2 small) Black Stamped in Red
35. D-2 1400 Plastic Shield Set
36. C-9767 Ball Shooter Gauge
37. B-2 1382 Metal Flat Rail

- |           |              |              |      |
|-----------|--------------|--------------|------|
| C-1 156 1 | Plastic Post | 1" High      | (33) |
| C-1 156 2 | Plastic Post | 1-3/16" High | (5)  |

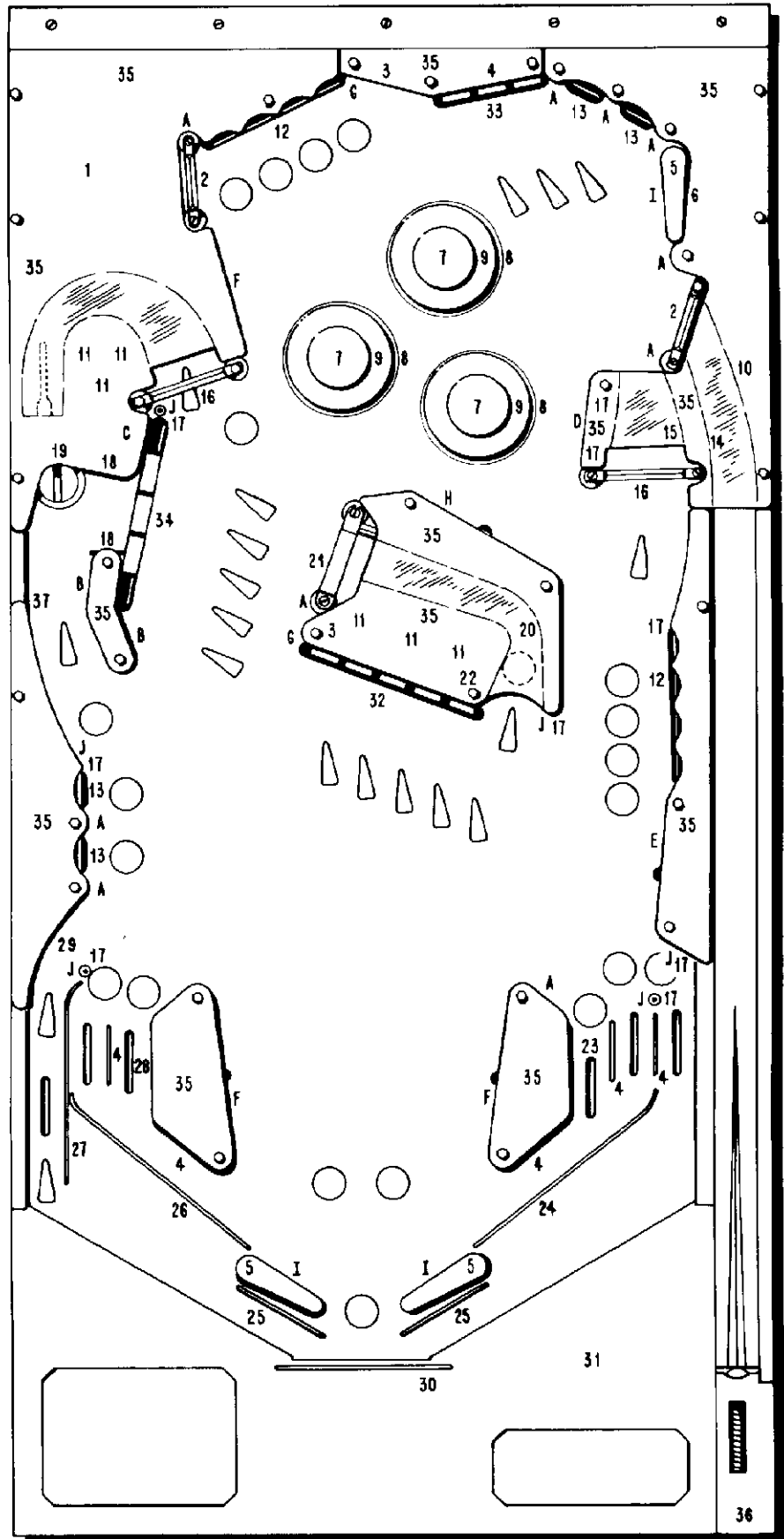

# XI. PARTS INFORMATION

## PLAYBOARD SWITCH MATRIX PARTS/LAMP ASSIGNMENTS

### SWITCH MATRIX

NO.	SWITCH ASSIGNMENT	PART NO.
00	# 1 Left Drop Target	B-18094
01	# 1 Right Drop Target	B-18094
02	# 1 Left Top Target	B-20867
03	# 1 Right Bottom Target	B-20867
04	# 1 Top Drop Target	B-18094
05	Top Ball Kicker	B-19754
06	Hole	B-19857
10	#2 Left Drop Target	B-18094
11	#2 Right Drop Target	B-18094
12	#2 Left Top Target	B-20867
13	#2 Right Bottom Target	B-20867
14	#2 Top Drop Target	B-18095
15	Left Spin Target	B-19353
16	Rollunder	B-21137
20	#3 Left Drop Target	B-18095
21	#3 Right Drop Target	B-18095
22	#3 Left Top Target	B-20867
23	#3 Right Bottom Target	B-20867
24	#3 Top Drop Target	B-18093
25	Right Top Target (2)	B-20867
26	Right Spin Target	B-19353
30	#4 Left Drop Target	B-18093
31	#4 Right Drop Target	B-18093
32	#4 Left Top Target	B-20867
33	#4 Right Bottom Target	B-20867
34	Pop Bumpers (3)	B-21359
35	Drop Target	B-18096
	Ten Point Switch	B-18079
36	Right Outside Rollover	B-18892
40	#5 Left Drop Target	B-18093
41	#5 Right Drop Target	B-18093
42	Left Outside Rollover	B-18892
43	Left Outside Return Rollover	B-18892
44	Left Inside Return Rollover	B-18892
45	#2 Left Bottom Target	B-21387
46	# 1 Left Bottom Target	B-21387
50	First Position Trough	B-18892
51	Third Position Trough	B-18892
52	Kicking Rubbers (5)	B-18808
53	Right Outside Return Rollover	B-18892
54	Right Inside Return Rollover	B-18892
55	Outhole	B-18892
57	Tilt	B-9141

### LAMP

NO.	LAMP ASSIGNMENT
L 3	Shoot Again
L 4	# 1 Right Bottom Target
L 5	# 2 Right Bottom Target
L 6	# 3 Right Bottom Target
L 7	# 4 Right Bottom Target
L 15	Right Outside Rollover
L 16	Pop Bumper (3)
L 17	Right Outside Return Rollover
L 18	# 1 Left Drop Target
L 19	# 2 Left Drop Target
L 20	# 3 Left Drop Target
L 21	# 4 Left Drop Target
L 22	# 5 Left Drop Target
L 23	# 1 Top Drop Target
L 24	# 2 Top Drop Target
L 25	# 3 Top Drop Target
L 26	# 1 Right Drop Target
L 27	# 2 Right Drop Target
L 28	# 3 Right Drop Target
L 29	# 4 Right Drop Target
L 30	# 5 Right Drop Target
L 31	Left Spin Target
L 32	Right Spin Target
L 33	Hole (2 Ball Multi-Ball)
L 34	Hole Capture
L 35	Top Kicker Capture
L 36	Top Left Bottom Target
L 37	Bottom Left Bottom Target
L 38	2X
L 39	3X
L 40	Inside Return Rollovers(2)
L 41	Left Outside Return Rollover
L 42	Rollunder
L 43	Extra Ball
L 44	# 1 Left Top Target
L 45	# 2 Left Top Target
L 46	# 3 Left Top Target
L 47	# 4 Left Top Target

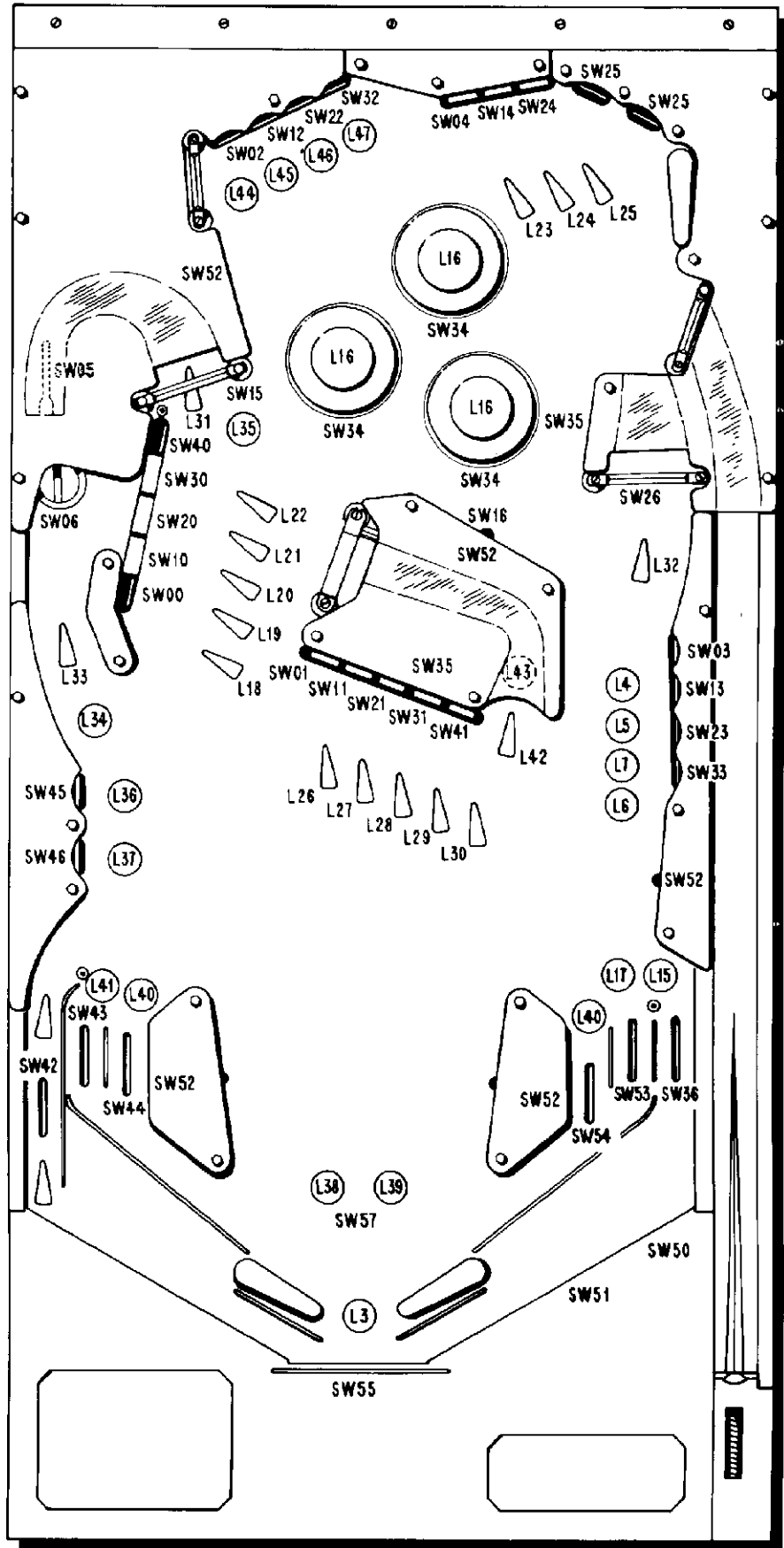

# XI. PARTS INFORMATION

## PLAYBOARD (UNDERSIDE) COMPONENTS

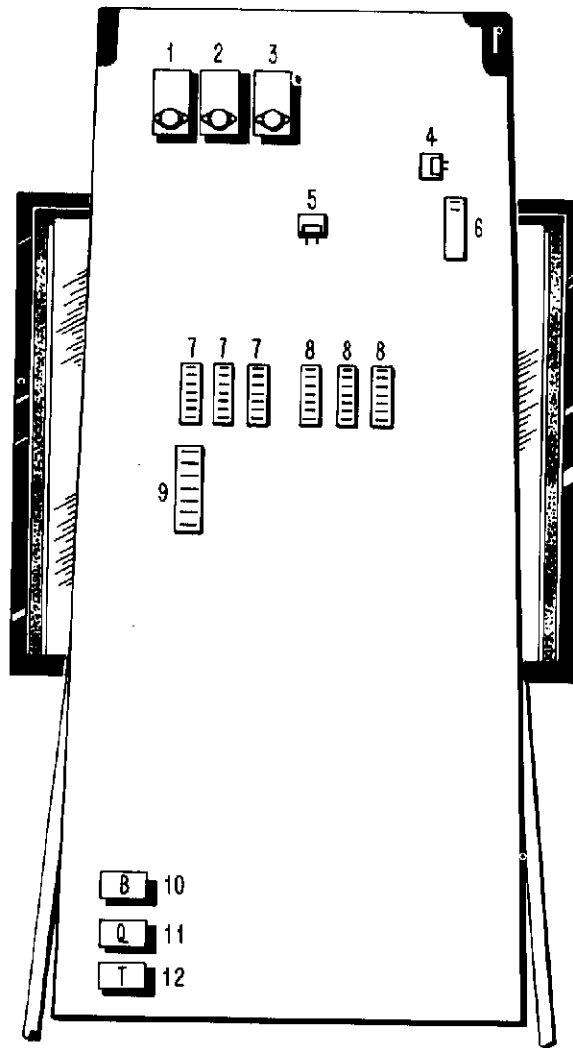

ITEM	DESCRIPTION	PART NO.
1.	Pop Bumper Driver Board	A-19741
2.	Pop Bumper Driver Board	A-19741
3.	Pop Bumper Driver Board	A-19741
4.	Transistor and Bracket	A-21618
5.	Transistor and Bracket	A-21618
6.	Two Resistor Terminal Strip	A-21634
7.	7 Diode Terminal Strip	A-21027
8.	7 Diode Terminal Strip	A-21027
9.	Fuse Strip 7 Position	EL-1
	F10, 11 & 12 1 Amp SLO-BLO	EL-6
	F13, 14, 15 & 16 2 Amp SLO-BLO	EL-7
10.	B Relay	MA-165
11.	Q Relay	MA-62
12.	T Relay	MA-63

# XI. PARTS INFORMATION

## PLAYBOARD ASSEMBLIES

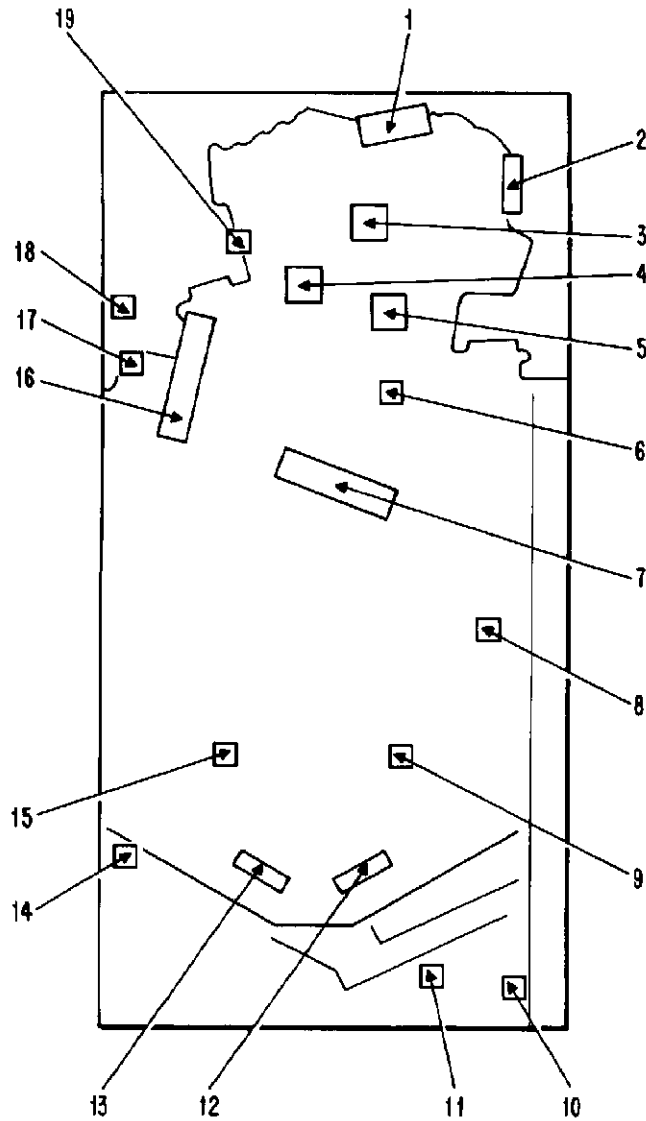

ITEM	DESCRIPTION	ASSEMBLY PART NO.	COIL PART NO.
1.	3 Position Target Bank	MA-183A	A-18102
2.	Flipper Unit Right	MA-22A	A-17875
3.	Pop Bumper	MA-29	A-1496
4.	Pop Bumper	MA-29	A-1496
5.	Pop Bumper	MA-29	A-1496
6.	Contact Kicker	MA-135	A-1496
7.	5 Position Target Bank	MA-43	A-17891
8.	Contact Kicker	MA-135A	A-1496
9.	Contact Kicker	MA-135A	A-1496
10.	Ball Return Gate	C-20607	A-16570
11.	Ball Return Unit	C-18638	A-16570
12.	Flipper Right	MA-91A	A-20095
13.	Flipper Left	MA-91	A-20095
14.	Kicking Coil	B-21001	A-4893
15.	Contact Kicker	MA-135A	A-1496
16.	5 Position Target Bank	MA-218	A-17891
17.	Hole Kicker	MA-226	A-5195
18.	Contact Kicker	MA-41A	A-5194
19.	Contact Kicker	MA-135A	A-1496

# LIGHTBOX PARTS

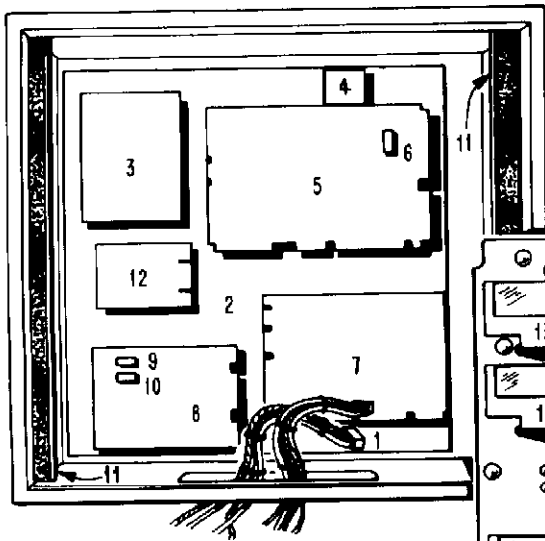

NOTE:  
LAMPS USED ARE  
\* 455 (10 EA) AND  
\* 44 (37 EA)

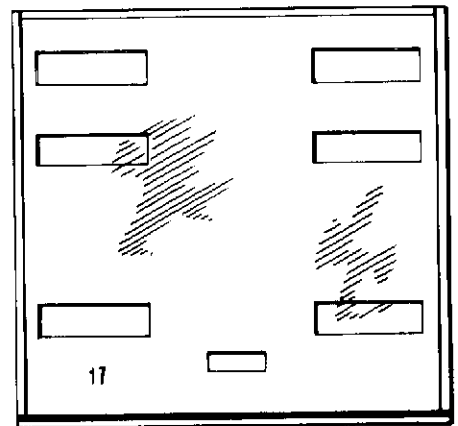
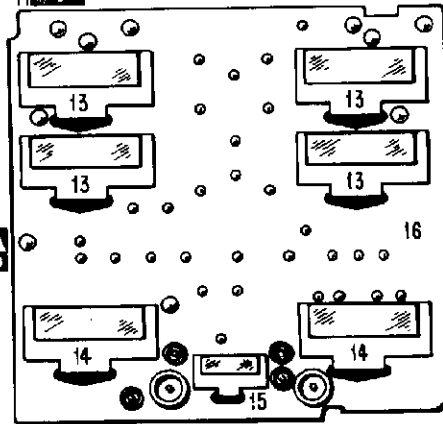

ITEM	DESCRIPTION	PART NO.
1.	Cable Assy.	Specify Game
2.	Lightbox Assy.	Specify Game
3.	Power Supply Assy.	MA-114
4.	Reset Board	MA-164
5.	Control Board	MA-291
6.	Game Prom	670
7.	Master Driver Board	MA-295
8.	Sound/Speech Board	MA-216
9.	Sound Prom	670/S2
10.	Sound Prom	670/S1
11.	Side Vent	D-20405
12.	Sound/Speech Power Supply	MA-188
13.	7 Digit Display	MA-238
14.	6 Digit Display	MA-116
15.	4 Digit Display	MA-115
16.	Insert	Specify Game
17.	Back Glass	Specify Game

**Gottlieb™**  
**AMUSEMENT GAMES**

155 W. Lake Street Northlake, IL 60164  
[312] 562-7400 Telex 72-8463

A Columbia Pictures Industries Company 