

DME Switcher

Model

DFS-500/500P

Operating Instructions

Before operating the unit, please read this manual thoroughly and retain it for future reference.



WARNING

To prevent fire or shock hazard, do not expose the unit to rain or moisture.

To avoid electrical shock, do not open the cabinet. Refer servicing to qualified personnel only.

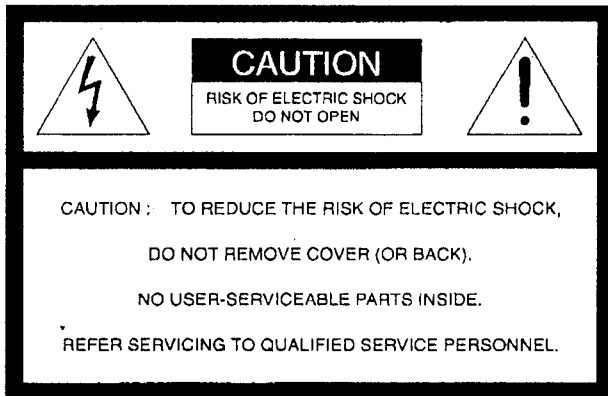

This symbol is intended to alert the user to the presence of uninsulated "dangerous voltage" within the product's enclosure that may be of sufficient magnitude to constitute a risk of electric shock to persons.



This symbol is intended to alert the user to the presence of important operating and maintenance (servicing) instructions in the literature accompanying the appliance.

Owner's Record

The model and serial numbers are located on the rear panel. Record these numbers in the spaces provided below. Refer to them whenever you call your Sony dealer regarding this product.

Model No. _____ Serial No. _____

For customers in the U.S.A.

WARNING

This equipment has been tested and found to comply with the limits for a Class A digital device, pursuant to Part 15 of the FCC Rules. These limits are designed to provide reasonable protection against harmful interference when the equipment is operated in a commercial environment. This equipment generates, uses, and can radiate radio frequency energy and, if not installed and used in accordance with the instruction manual, may cause harmful interference to radio communications. Operation of this equipment in a residential area is likely to cause harmful interference in which case the user will be required to correct the interference at his own expense.

You are cautioned that any changes or modifications not expressly approved in this manual could void your authority to operate this equipment.

The shielded interface cable recommended in this manual must be used with this equipment in order to comply with the limits for a digital device pursuant to Subpart B of Part 15 of FCC rules.

For the customers in Canada

This apparatus complies with the Class A limits for radio noise emissions set out in Radio Interference Regulations.

Table of Contents

Chapter 1 Overview

Chapter 2 Location and Function of Parts and Controls

Chapter 3 Preparations

Chapter 4 Introduction too the DME Switcher

Chapter 5 Operation

(to be continued)

About This Manual	5
Features	1-2
Optional Accessories	1-5
Control Panel	2-2
Processor Unit	2-18
Rear Panel	2-18
Front Panel and Internal Boards	2-21
Precautions	3-2
Safety Precautions	3-2
Handling Precautions	3-2
Power Connection and Initialization	3-3
Connections	3-5
Basic System Connections	3-5
Key Signal Connections	3-6
A-roll Editing System Connections	3-7
A/B-roll Editing System Connections	3-8
Connection with the BVS-3000	3-10
Settings of the Internal Switches	3-11
Flow of Operation	4-2
Basic Operation	4-3
Wipe	4-3
Picture-in-Picture	4-6
Demonstration	4-9
Selecting Pictures	5-2
Selecting an Effect	5-4
Effects of the DFS-500/500P	5-4
Direct Pattern Select Mode	5-10
Pattern Number Designation Mode	5-11
Modifying the Edge – Border and Soft Edge	5-13
Moving the Location of the Pattern – Location (X), (Y), (Z)	5-14
Modifying a Pattern – User-Modify Effects	5-16
Superimposing Characters (1) – Title Key	5-17
Adding Compound Effects	5-20
Lighting	5-21
Trail	5-22
Drop Border	5-23
Shadow	5-24
Superimposing Characters (2) – Downstream Key	5-25
Setting the Transition	5-30
Setting the Duration of the Transition	5-30
Selecting the Direction of the Transition	5-32

Table of Contents

Chapter 5 Operation	Executing the Effect 5-34 Adjusting the Color Matte 5-37 Adjusting the Color 5-37 Copying the Color-Matte Data 5-38
Chapter 6 Advanced Operation	Changing the Direct Pattern Assignment 6-2 User Program 6-4 Required Conditions for User-Program Effects 6-4 Creating a User-Program Effect 6-10 Editing a User-Program Effect 6-12 Executing a User-Program Effect 6-18 Deleting a User-Program Effect 6-19 Snap Shot 6-20 Storing the Snap Shot Data 6-21 Recalling the Snap Shot 6-22
Chapter 7 Control with the Editing Control Unit	Control from the RM-450 7-2 Control from the BVE-600 7-5 A-roll Editing 7-6 A/B-roll Editing 7-7 Control using a GPI Signal 7-8 A-roll Editing 7-9 A/B-roll Editing 7-10 Control from the BVE-900 Series 7-12 Control from the BVS-3000 Series 7-14 Interface Functions according to the System Configuration 7-19
Appendixes	Specifications A-2 Recommended Equipment and Cables A-4 Glossary A-5 Types of Effects A-7 Adjustable Parameters A-8 Effects Classified by Type of Motion A-10 Parameters for Modifying Effect Patterns A-11 Effect Patterns Image List A-14
	Index I-1

About This Manual

Purpose of this Manual

This is the operation manual for the DFS-500/500P DME switcher. It gives you all the information you need to set up a video system with the DFS-500/500P, such as connections, necessary adjustments, and to operate the DFS-500/500P for switching pictures using special effects. This manual also provides effect pattern image list to show you all the built-in effect patterns.

The manual is intended for users who have knowledge and experience with professional video systems and its operation, from cable television stations to general business operators. If you are an experienced user of the video editing system, reading Chapter 2 "Location and Function of Parts and Controls" will be sufficient to grasp the principal functions of the DFS-500/500P. If you have limited experience with the video editing system, you should preferably read through the manual. The Glossary at the end gives the meaning of technical terms.

Organization of this Manual

This manual is divided into the following seven chapters.

Chapter 1 Overview

Introduces the DFS-500/500P features and optional boards, which expand the functions of the DFS-500/500P.

Chapter 2 Location and Function of Parts and Controls

Gives the names and functions of the controls and other parts on the control panel and processor unit which the DFS-500/500P is composed of. Experienced users of professional video editing systems may start using the DFS-500/500P after reading this chapter.

Chapter 3 Preparations

Describes connections and internal switch settings according to your purpose and some safety precautions you should be aware of.

Chapter 4 Introduction to the DME switcher

Describes basic operation using two types of built-in effects, to familiarize you with a system equipped with the DFS-500/500P.

Chapter 5 Operation

Describes operating procedures from the beginning to the execution of effects using the 13 built-in typical effect patterns. How to superimpose characters on a picture and how to modify effect patterns are also explained here.

Chapter 6 Advanced Operation

Explains a variety of functions using memory with which you can execute a number of effect patterns more easily.

About This Manual

Chapter 7 Control with the Editing Control Unit

Gives the required preparations, settings and conditions when a connected external video equipment such as an editing control unit or video switcher controls the DFS-500/500P.

Refer to the operation manual provided with the connected equipment.

Appendixes

Provides the following information:

- Specifications
- Glossary
- Data for effect patterns

Effects patterns are introduced in tables according to type, parameters, and motion type. You can check the effect patterns which can be modified with the parameters described in the tables in the Appendixes. At the end, all effects patterns available on the DFS-500/500P are illustrated.

An index is provided at the end of this manual.



Chapter 1 Overview

This chapter introduces the features of the DFS-500/500P and the optional boards.

Features	1-2
Optional Accessories	1-5

Features

The DFS-500/500P DME switcher is a compact, high-performance video switcher having digital multi-effect functions.

Special effects without TBC

Thanks to the two built-in frame synchronizers enables editing of video signals with special effects without using a time base corrector (TBC), which is normally essential for an editing system.

Multiple special effects, including DME (Digital Multi Effects)

The touch of a button can select a variety of effects, such as cut, mix, four wipe patterns, and also DME patterns such as slide, three-dimensional rotation, turn, twist, page turn, picture-in-picture and sphere.

In addition, 66 wipe patterns and 246 DME patterns are selectable with a simple button operation. Variation of patterns is also available with some patterns using edge, location and modify functions.

User program

Besides built-in effect patterns, up to 40 patterns can be created as desired and be stored. These stored patterns can be executed in the same way as the built-in effects.

Wide range of the duration of transition

The duration of transition for effects such as wipe, mix and downstream key mix, can be varied within a range of 0 through 999 frames in one-frame steps, and the effects can be automatically executed.

Snap shot function

With the DFS-500/500P, you can store your settings on the control panel in the snap shot registers 0 through 99 on the processor unit. The stored settings can easily be recalled at any time.

Matte generator

The DFS-500/500P has five color matte generators for color background, border matte, etc. You can select the desired colors of effect patterns or superimposed characters.



Optional functions for improving visual effects

With an optional board installed, lighting or trail effects can be added to the effect patterns.

Variety of input/output connectors for various signal formats

The DFS-500/500P is provided with input and output connectors for a composite signal, component signal and an S-video (Y/C) signal, which allow it to accept and supply signals of various formats.

- Primary video signal inputs (3 formats, 4 inputs)

Four signals of different formats, selected with the internal switch can be input as primary video signals.

- Program video signal outputs (3 formats, 2 outputs)

Two output connectors are provided for each format to supply six output signals.

Sync-signal input/output for improving editing accuracy

The black-burst signal output connectors are provided to synchronize connected equipment with the DFS-500/500P. To synchronize the DFS-500/500P with external equipment, the gen-lock input connector is also included. These connectors allow highly accurate editing.

- Black-burst signal output (4 outputs)
- Gen-lock input (1 input)

Key-signal input for superimposing characters or figures

The DFS-500/500P has input connectors for title key and downstream key (DSK) functions to superimpose characters or figures on a picture. To activate the downstream key function, an optional BKDF-502/502P DSK board is necessary.

- External key-source signal input for title key (1 input)
- Key fill signal input for downstream key (1 input)
- External key-source signal input for downstream key (1 input)

Key-signal output for another switcher

The DFS-500/500P can supply a key-source signal to another video switcher.

- Key-source signal output (1 output)

Features

Interface with an editing control unit

The two types of control signals allow the DFS-500/500P to construct editing systems with various editing equipment.

The BVE-600 or BVE-900 series editing control unit constructs an A/B roll editing system (two players and one recorder) with the DFS-500/500P.

In combination with the RM-450, editing using special effects is possible in the A roll editing system (one player and one recorder).

When the BVS-3000 series video switcher is included in the system, the effects of the BVS-3000 series are added to the effects of the DFS-500/500P.

In addition, the GPI (General-Purpose Interface) signal control is also available to expand the possibilities of various editing systems.

- 9-pin interface connector (1 input/output)
- Cue/trigger/GPI signal input (2 inputs)

Rack mounting

The processor unit and the control panel of the DFS-500/500P can be mounted in an EIA standard 19-inch rack. To mount the control panel, an optional BKDF-503 control panel mount adaptor is necessary.

Optional Accessories

The following optional boards are available for the DFS-500/500P.

For details on installation, refer to the installation instructions for the board.

BKDF-501/501P trail and lighting board

This board enables the trail and lighting functions, and drop border and shadow effects.

Insert this board into one of the slots in the processor unit of the DFS-500/500P.

BKDF-502/502P DSK board

This board enables the downstream key function.

Mount this board to the DA-63 board in the processor unit of the DFS-500/500P.

BKDF-503 control panel mount adaptor

Using this adaptor, the control panel can be mounted in a 19-inch rack (height: 354 mm, 8U).

Attach the adaptor to the control panel using the screws supplied with the BKDF-503, and mount them in a control console.

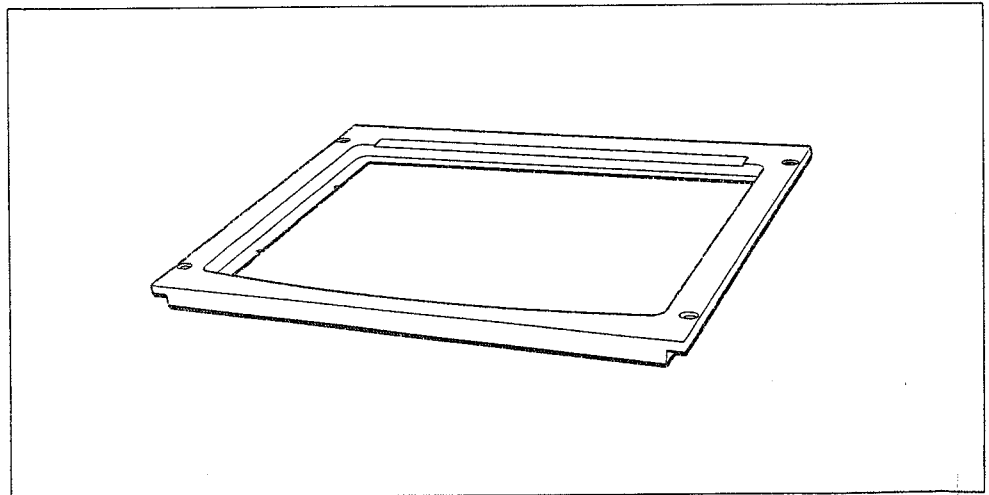

BKDF-503

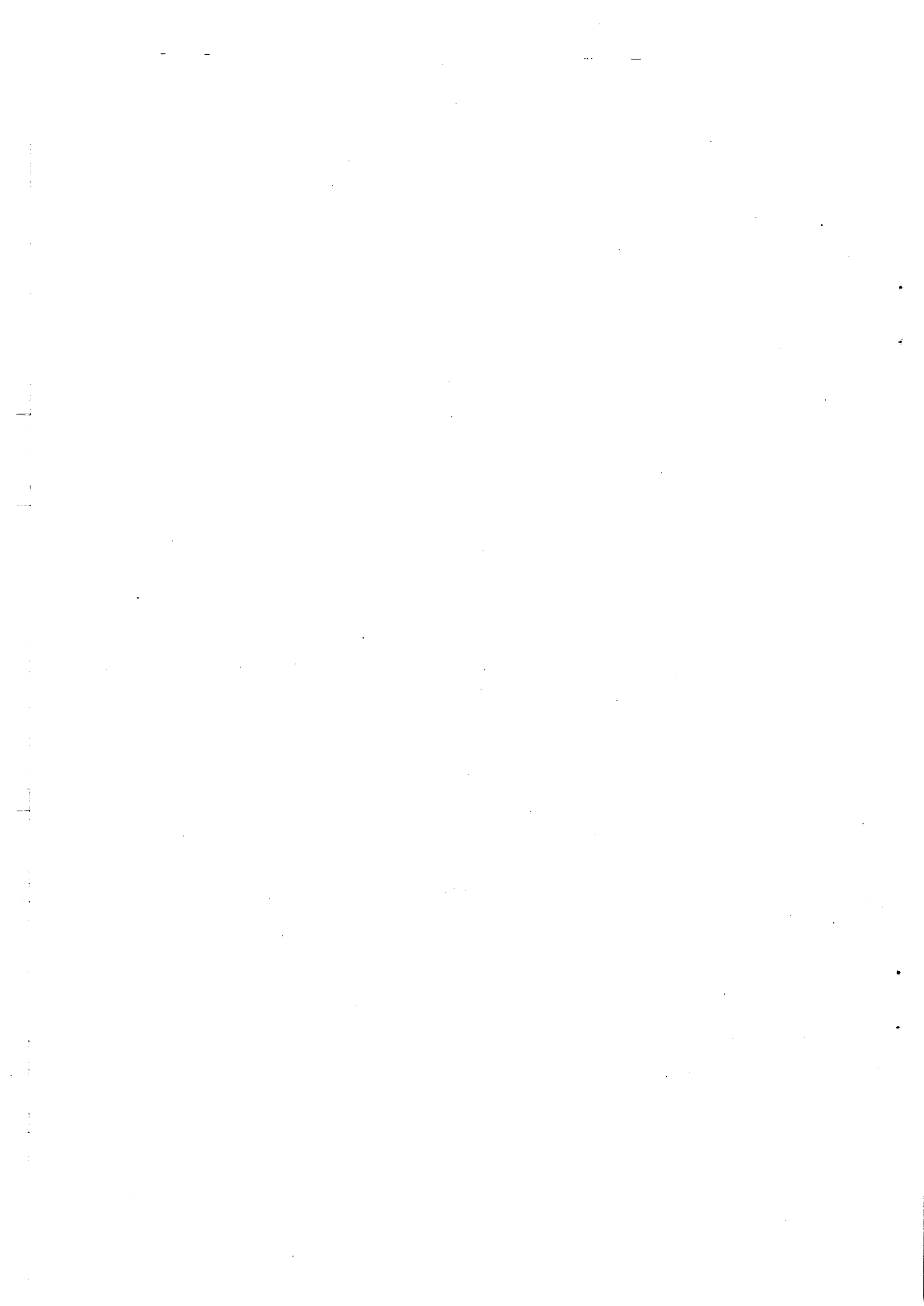

Chapter 2

Location and Function of Parts and Controls

This chapter gives the locations and functions of the controls and other parts on the control panel and processor unit which the DFS-500/500P is composed of for each functional section.

Control Panel	2-2
Processor Unit	2-18
Rear Panel	2-18
Front Panel and Internal Boards	2-21

Control Panel

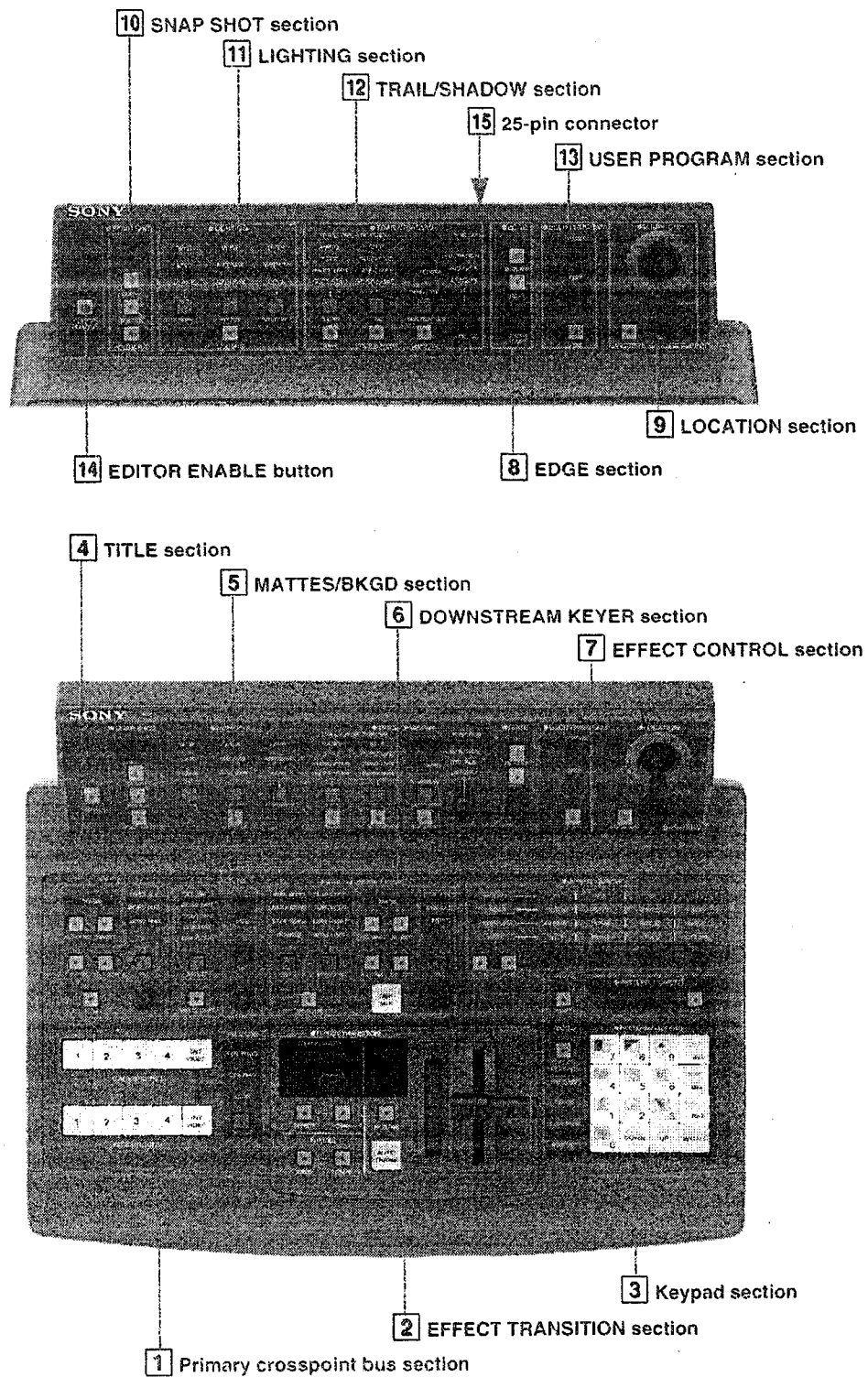

Control panel

Note

When you perform an incorrect operation, a warning sound is heard, and the indicators of the buttons and the display windows related to the operation flash three times.

1 Primary crosspoint bus section

This section consists of the buttons to select the pictures over which an effect will appear or on which an effect will be applied.

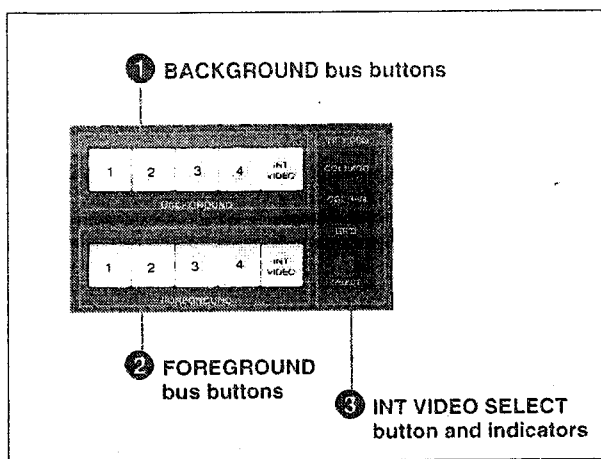

Primary crosspoint bus section

1 BACKGROUND bus buttons

Select a background picture which will disappear after an effect.

Buttons 1 through 4 correspond to the VIDEO INPUTS 1 through 4 connectors on the rear panel of the processor unit. When you press a button, the pressed button lights and the picture input to the corresponding connector is selected.

Pressing the INT VIDEO button selects a video signal generated by the built-in signal generator (built-in video signal), which is selected with the INT VIDEO SELECT button 3.

When the signal selected with the BACKGROUND bus buttons is output from the PGM OUT connector on the rear panel, the indicator of the button is lit in red, but when not output, it is lit in amber.

2 FOREGROUND bus buttons

Select a foreground picture which will appear when an effect is executed.

Buttons 1 through 4 correspond to the VIDEO INPUTS 1 through 4 connectors on the rear panel of the processor unit. When you press a button, the pressed button lights, and the picture input to the corresponding connector is selected.

Pressing the INT VIDEO button selects a built-in video signal, which is selected with the INT VIDEO SELECT button 3.

When the signal selected with the FOREGROUND bus buttons is output from the PGM OUT connector on the rear panel, the indicator of the button is lit in red, but when not output, it is lit in amber.

Note

When the controller select switch on the internal board of the processor unit (see page 2-25) is set to BVS-3000, the signal selected with the BACKGROUND bus buttons is not output from the PGM OUT connector. Only the signal selected with the FOREGROUND bus button is output from the PGM OUT connector, which is input to the BVS-3000.

3 INT VIDEO SELECT (internal-video-signal select) button and indicators

Selects one of the signals generated by the built-in signal generators when the signal is used for a foreground or background picture, or when the effect using the internal video signal is being executed.

Every time the button is pressed, a color-background signal, color-bar signal or grid-pattern signal is selected alternately, and the corresponding indicator lights.

COL BKGD: A color-background signal

COL BAR: A color-bar signal

GRID: A grid-pattern signal

When you select COL BKGD, 15 kinds of pattern signals can be selected besides the color-matte signal. While the COL BKGD indicator is lit, press the UP or DOWN button in the keypad section 3 while holding down the INT VIDEO button of the FOREGROUND or BACKGROUND bus buttons.

Changing the label

You can change the labels on the FOREGROUND and BACKGROUND bus buttons with the supplied labels (VTR, CAM, etc.) according to the input signal.

See page 6-3 for details.

Control Panel

2 EFFECT TRANSITION section

This section consists of the buttons and lever used for setting or operating transition for an effect or downstream key.

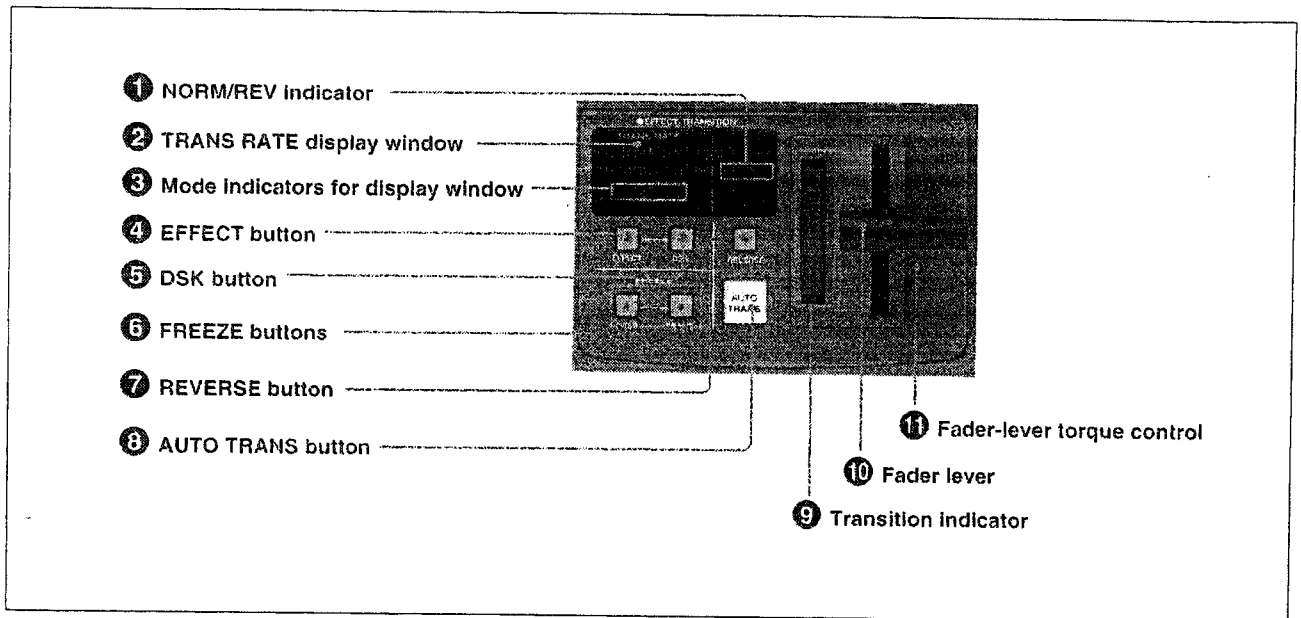

EFFECT TRANSITION section

1 NORM/REV (normal/reverse) indicator

Lights when an effect with normal/reverse motion (animation-type effect or title key) is being executed.

When the controller select switch on the internal board of the processor unit is set to BVE-600/RM-450, this indicator does not light.

2 TRANS RATE (transition rate) display window

Shows the duration of the transition for an effect or downstream key in units of frames. The duration is displayed in three digits. While setting the duration, dots light at the lower right of the digits.

3 Mode indicators for display window

Shows the kind of duration being displayed in the TRANS RATE display window 2.

EFFECT: The duration of the transition for an effect is displayed.

DSK: The duration of the transition for a downstream key is displayed.

4 EFFECT (effect-duration setting) button

Press to select the effect-duration setting mode, and the indicator of the button, the EFFECT indicator 3 and the TRANS indicator in the keypad section 3 light. Specify the desired duration for effects using the PATTERN/KEY PAD buttons in the keypad section, and press the ENTER button.

Pressing the button again makes the indicator go out, and effect-duration setting mode is released.

5 DSK (downstream-key duration setting) button

Press to select the downstream-key duration setting mode, and the indicator of the button, the DSK indicator 3 and the TRANS indicator in the keypad section 3 light. Specify the desired duration for the downstream key using the PATTERN/KEY PAD buttons in the keypad section, and press the ENTER button.

Pressing the button again makes the indicator go out, and downstream-key duration setting mode is released.

Note

If the USER PGM indicator in the keypad section 3 is lit, effect-duration or downstream-key duration setting mode cannot be selected by pressing the EFFECT button 4 or DSK button 5, but a warning sound is heard. In such a case, press the EDIT button in the USER PROGRAM section 13 to release user-program edit mode.

6 FREEZE buttons

Freeze a background picture while executing an effect.

FIELD button: When you press this button, the indicator of the button lights, and field freeze mode is selected.

FRAME button: When you press this button, the indicator of the button lights, and frame freeze mode is selected.

To release field or frame freeze mode, press the button whose indicator is lit to make the indicator go out.

7 REVERSE button

Reverses the direction of the transition. When the indicator of the button is not lit, the direction is normal, and when the indicator is lit, it is reverse. When an effect with back-and-forth motion is executed, the direction is automatically reversed after executing the effect. After executing an effect in the normal direction, the indicator of the REVERSE button lights, and after executing an effect in the reverse direction, the indicator goes out.

8 AUTO TRANS (automatic transition) button

Press to execute the effect transition automatically with the set duration of the transition. During transition, the pressed button is lit.

Pressing this button during transition momentarily stops the transition, and pressing the button again resumes the transition.

When you press this button with the fader lever 10 placed at the position in between, transition momentarily stops at the point corresponding to the fader-lever setting.

9 Transition indicator

Shows the process of effect transition with the 20 LEDs.

10 Fader lever

Slide the lever to execute the transition manually.

Note

After turning on the unit, move the fader lever from one end to the other. This activates the fader lever.

11 Fader-lever torque control

Adjusts the torque of the lever. Turn the screw with a small Phillips screwdriver. Turning it clockwise increases torque, and counterclockwise decreases it.

Control Panel

3 Keypad section

This section consists of the buttons used to set data for selecting an effect pattern, setting the duration of the transition, etc.

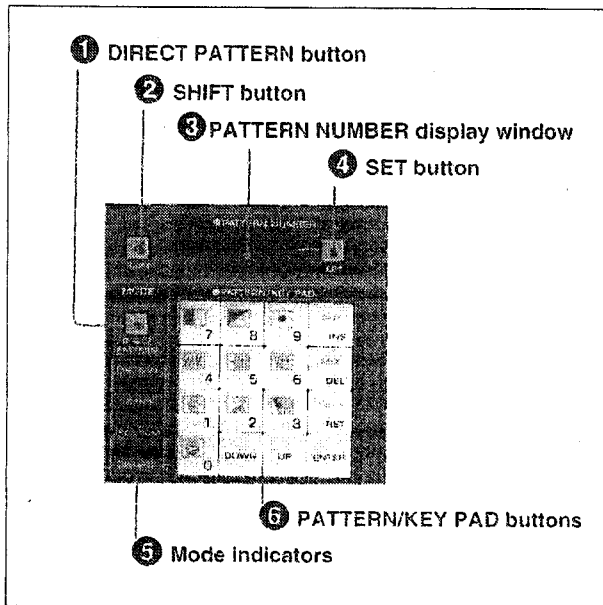

Keypad section

1 DIRECT PATTERN (direct pattern select mode on/off) button

Press to select direct pattern select mode, and the indicator of the button lights. In this mode, an effect pattern assigned to each PATTERN/KEY PAD button 6 (except for the UP, DOWN and ENTER buttons) is directly selected.

When the unit is turned on or when another operation mode is released, direct pattern select mode is automatically selected.

Note

When the USER PGM indicator of the mode indicators is lit, direct pattern select mode cannot be selected by pressing the DIRECT PATTERN button, but a warning sound is heard. Press the EDIT button in the USER PROGRAM section 13 to release user-program edit mode.

2 SHIFT button

Button for expanding functions.

3 PATTERN NUMBER display window

Shows the effect pattern number in four digits. Dots light at the lower right of the digits while entering the pattern number.

In user-program edit mode, values for parameters may be displayed here.

4 SET (pattern number designation mode on/off) button

Press to select pattern number designation mode and the indicator of the button and the PATTERN indicator 5 light, and the pattern number designation mode is selected. In this mode, an effect pattern number can be designated with the PATTERN/KEY PAD buttons.

Pressing the button again makes the indicator of the button go out and direct pattern select mode is retrieved.

Note

When the USER PGM indicator of the mode indicators is lit, pattern number designation mode cannot be selected by pressing the SET button, but a warning sound is heard. Press the EDIT button in the USER PROGRAM section 13 to release user-program edit mode.

5 Mode indicators

Indicate the modes other than direct pattern select mode. When the unit is in one of the following mode, the corresponding indicator is lit.

PATTERN: Pattern number designation mode.

You can designate the effect pattern by entering the pattern number. When you press the SET button 4, the indicator of the button lights and pattern number designation mode is obtained.

TRANS: Transition duration setting mode. You can set the duration of the transition for an effect or downstream key in units of frames. The buttons in the EFFECT TRANSITION section 2 are also used for setting the duration.

USER PGM: User-program edit mode. You can create and edit the user program with the buttons and controls in the USER PROGRAM section 13, EFFECT CONTROL section 7 and LOCATION section 9.

SNAP SHOT: Snap shot number setting mode.

You can set the snap shot number from 0 to 99 which designates the register for storing the settings on the control panel and for recalling the stored data with the buttons in the SNAP SHOT section 10.

⑥ PATTERN/KEY PAD buttons

Function as follows according to the selected mode.

Changing the label

You can change the labels on the PATTERN/KEY PAD buttons with the supplied labels according to the assigned effect pattern.

See page 6-3 for details.

Functions of the PATTERN/KEY PAD buttons

Buttons	Mode				
	DIRECT PATTERN	PATTERN	TRANS	USER PGM	SNAP SHOT
0 to 9	Selects an assigned pattern ^{a)}	Designates the pattern number	Sets the duration of the transition	Displays parameter values	Designates a snap shot number
INS	Selects CUT	—	—	Inserts a key frame	—
DEL	Selects MIX	—	—	Deletes a key frame	—
RST	Selects P IN P	Resets the input value to 0	Resets the input value to 0	Initializes parameters	Resets the input value to 0
UP	Adds one to the selected pattern number	Adds one to the selected pattern number	Adds one frame to the duration of the transition	Adds one to the selected key frame number	Adds one to the selected snap shot number
DOWN	Subtracts one from the selected pattern number	Subtracts one from the selected pattern number	Subtracts one frame from the duration of the transition	Subtracts one from the selected key frame number	Subtracts one from the selected snap shot number
ENTER	—	Activates the entered value	Activates the entered value	Modifies key frame data	Activates the entered value

—: Not used

a) For details on the pattern assignment, see page 5-5.

Control Panel

4 TITLE section

This section consists of the buttons and controls used to superimpose characters or figures on a background picture by cutting a foreground picture with a key-source signal (title mode). An effect will be applied to the characters or figures to be inserted.

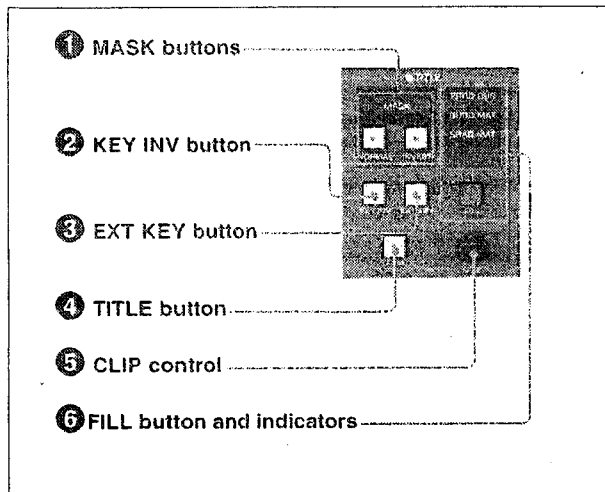

TITLE section

1 MASK (key mask on/off) buttons

Press to mask a part of characters or figures inserted on a background picture, and the indicator of the button lights (mask mode). Pressing the button again makes the indicator go out and mask mode is released.

NORMAL button: Press to mask the outside of the rectangular area defined with the buttons in the EFFECT CONTROL section [7].

INVERT button: Press to mask the inside of the rectangular area defined with the buttons in the EFFECT CONTROL section.

Note

The NORMAL and INVERT masks cannot be used simultaneously.

2 KEY INV (key invert) button

Press to invert the polarity (black and white) of a key-source signal, and the indicator of the button lights. Pressing the button again makes the indicator go out, and restores the original polarity.

3 EXT KEY (external key) button

Press to select a signal input to the EXT KEY IN connector as a key-source signal, and the indicator of the button lights. Pressing the button again makes the indicator of the button go out, and the key-source signal is changed to the signal selected with the FOREGROUND bus buttons (a self-key source signal made from a luminance signal of the picture input to the VIDEO INPUTS connectors).

Note

The signal input to the EXT KEY IN connector should be synchronized with the signal selected with the FOREGROUND bus button (a key-fill signal).

4 TITLE (title on/off) button

Press to activate title mode, and the indicator of the button lights. In title mode, a foreground picture cut with the key-source signal is inserted in the background picture. Pressing the button again makes the indicator of the button go out, and title mode is released.

5 CLIP (key-clipping level) control

Adjusts the clipping level (threshold luminance level) to specify the amount of key of the key-source signal selected with the FOREGROUND bus buttons.

Notes

- You cannot use the CLIP control to adjust a clipping level of a signal input to the EXT KEY IN connector. To adjust the level, turn the EXT KEY CLIP VRs on the AD-76 board.
- When title mode is turned off, or the indicator of the EXT KEY button [3] is lit, turning the CLIP control makes a warning sound.

6 FILL (key-fill signal select) button and indicators

Selects a signal which fills a part cut with the key-source signal. Every time the button is pressed, a foreground bus picture, border matte or shadow matte is selected alternately and the corresponding indicator lights.

FRGD BUS: A picture selected with the FOREGROUND bus button

BORD MAT: A border matte

SHAD MAT: A shadow matte

Note

When a signal input to the EXT KEY IN connector is used as a key-source signal, you cannot select a built-in video signal of the foreground bus as a key-source signal.

5 MATTES/BKGD (matte/background) section

This section consists of the buttons and controls to adjust the color-matte generator for a color background, border or shadow of effects, a fill signal or border of a downstream key.

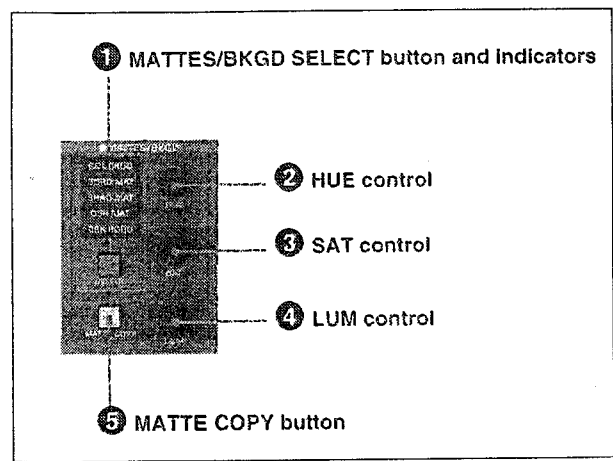

MATTES/BKGD section

1 MATTES/BKGD SELECT (matte/background select) button and indicators

Selects the color matte to be adjusted. Every time the button is pressed, a color background, border matte, shadow matte, DSK matte, or DSK border matte is selected alternately, and the corresponding indicator lights.

COL BKGD: The color background selected with the INT VIDEO button in the primary crosspoint bus section **1**.

BORD MAT: The border matte used for a border selected with the EDGE section **8**, for a compound effect selected with the TRAIL/SHADOW section **12** or for a key-fill signal for a title.

SHAD MAT: The shadow matte which is used for a compound effect selected with the TRAIL/SHADOW section or for a key-fill signal for a title.

DSK MAT: The DSK matte which is used as a key-fill signal for a downstream key.

DSK BORD: The DSK border matte which is used for the border for a downstream key.

Notes

- Each color matte is automatically selected just by pressing the corresponding button. You need not press the SELECT button. For example, when BORDER is selected in the EDGE section **8**, a border matte is automatically selected.
- The DSK matte or DSK border matte cannot be selected when the BKDF-502/502P DSK board (optional) is not installed in the processor unit or when the controller select switch on the SY-172 board in the processor unit is set to BVS-3000.

2 HUE control

Adjusts the hue of the color matte selected with the MATTES/BKGD SELECT button **1**.

3 SAT (saturation) control

Adjusts the saturation level of the color matte selected with the MATTES/BKGD SELECT button.

4 LUM (luminance) control

Adjusts the luminance level of the color matte selected with the MATTES/BKGD SELECT button.

5 MATTE COPY button

Press to copy a color set on a color matte onto another color matte.

For details, see "Copying a Color Matte Data" on page 5-38.

Control Panel

6 DOWNSTREAM KEYER section

This section consists of the buttons and control to make settings for a downstream key, which superimposes characters or figures on a program picture made of a foreground picture and a background picture.

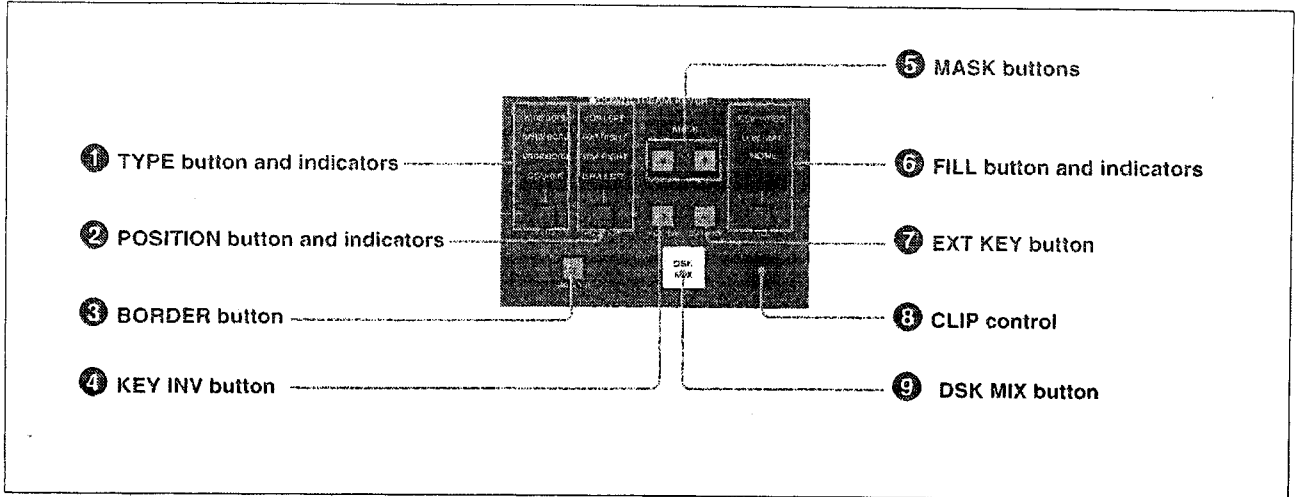

DOWNSTREAM KEYER section

Notes

- A downstream key function cannot be used when the BKDF-502/502P DSK board (optional) is not installed in the processor unit or when the controller select switch on the SY-172 board in the processor unit is set to BVS-3000.
- A signal used for a downstream key is input to the DSK VIDEO IN and DSK KEY IN connectors on the processor unit. These signals should be synchronized with the reference signal generated by the built-in signal generator.

1 TYPE (border type select) button and indicators

Selects a type of border to be added to the downstream-key signal. Every time the TYPE button is pressed, a wider border, narrow border, drop border or double border is selected alternately and the corresponding indicator lights.

WIDE BORD: A wide border

NARW BORD: A narrow border

DROP BORD: A drop border like a shadow

DOUBLE: A double border (combination border of a narrow border and drop border)

2 POSITION (border position select) button and indicators

Selects the position where the drop or double border is added to the downstream-key signal. Every time the button is pressed, the position of top left, top right, bottom right or bottom left is selected alternately, and the corresponding indicator lights.

TOP LEFT: Top left position

TOP RIGHT: Top right position

BTM RIGHT: Bottom right position

BTM LEFT: Bottom left position

3 BORDER (border on/off) button

Press to add the border to the downstream key, and the indicator of the button lights.

Pressing the button again makes the indicator of the button go out and the border disappears.

4 KEY INV (key invert) button

Press to invert the polarity (black and white) of a DSK key-source signal, and the indicator of the button lights. Pressing the button again makes the indicator of the button go out and restores the original polarity.

5 MASK (key mask on/off) buttons

Press to mask a part of the area which is cut with the DSK key-source signal, and the indicator of the button lights (mask mode). Pressing the button again makes the indicator of the button go out and mask mode is released.

NORMAL button: Press to mask the outside of the rectangular area defined with the buttons in the EFFECT CONTROL section [7].

INVERT button: Press to mask the inside of the rectangular area defined with the buttons in the EFFECT CONTROL section.

Note

The NORMAL and INVERT masks cannot be used together.

6 FILL (key-fill signal select) button and indicators

Selects a signal which fills a hole cut with the DSK key-source signal. Every time the button is pressed, a DSK video, DSK matte or no fill signal is selected alternately, and the corresponding indicator lights.

DSK VIDEO: A signal input to the DSK VIDEO IN connector on the processor unit

DSK MAT: A signal generated by the built-in DSK matte generator

NONE: No fill signal is selected, but only a border is added.

Note

When NONE is selected as the key-fill signal, a DSK border is automatically selected. If the DSK border is turned off, no downstream key is inserted even if the DSK MIX button 9 is pressed.

7 EXT KEY (external key) button

Press to select a signal input to the DSK KEY IN connector as a key-source signal, and the indicator of the button lights. Pressing the button again makes the indicator of the button go out, and the key-source signal is changed to a luminance signal of the video signal input to the DSK VIDEO IN connector on the processor unit.

8 CLIP (key clipping level) control

Adjusts the clipping level (threshold luminance level to specify the amount of key) of the downstream-key source signal input to the DSK VIDEO IN connector so that the outline of the characters or figures inserted becomes clear.

Notes

- You cannot use the CLIP control to adjust the clipping level of an external key source signal input to the DSK KEY IN connector. To adjust the level, turn the DSK EXT KEY CLIP VR on the DA-63 board in the processor unit.
- When a downstream-key signal is not inserted in a picture or when the indicator of the EXT KEY button 7 is lit, turning the CLIP control makes a warning sound.

9 DSK MIX (downstream-key mix) button

Press to insert or remove a downstream-key signal to and from a picture. When you press the button, the downstream key signal is gradually inserted with the duration of transition set by the buttons in the keypad section [3]. When the duration is set to 0, the signal is inserted in an instant (cut in).

While the signal is being inserted, the button is lit in amber, and when the signal insertion completes, the button light changes to red, which indicates that the downstream-key signal is inserted. Pressing the button again makes the button light in amber again, and the inserted signal gradually goes out with the specified duration of transition. When the duration is set to 0, the inserted signal disappears in an instant (cut out).

When a downstream-key signal completely disappears, the button light goes out.

Control Panel

7 EFFECT CONTROL section

This section consists of the buttons and controls to set various parameters for effects.

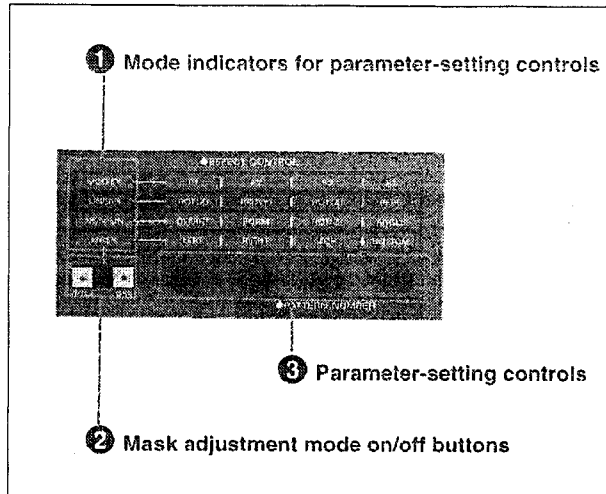

EFFECT CONTROL section

1 Mode indicators for parameter-setting controls

Indicate the control mode using the parameter-setting controls 3.

MODIFY: Indicates that a user-modify effect, whose pattern can be modified, is selected. In this mode, parameters for user-modify effects can be changed.

LINEAR: Indicates that a linear-type (two- or three-dimensional) user-program effect (that a user can make up) can be created or edited.

NON-LIN: Indicates that a non-linear-type user-program effect (that a user can make up) can be created or edited.

MASK: Indicates that one of the mask adjustment mode on/off buttons 2 is pressed. In this mode, the masking area for a title or downstream key can be adjusted.

2 Mask-adjustment mode on/off buttons

Turn on or off the mask adjustment mode for a title key or downstream key.

TITLE button: Press this button, and the indicator of the button and the MASK indicator 1 light. Then you can adjust the title mask area with the parameter-setting controls 3. Pressing the button again releases the title mask mode.

DSK button: Press this button, and the indicator of the button and the MASK indicator light. Then you can adjust the downstream-key mask area with the parameter-setting controls. Pressing the button again releases downstream-key mask mode.

Notes

- When the LINEAR or NON-LIN indicator 1 is lit, mask mode cannot be selected even if you press one of the MASK buttons, but a warning sound is heard. Press the EDIT button in the USER PROGRAM section 13 to make the indicator of the button go out.
- The title mask and downstream-key mask cannot be adjusted simultaneously.

3 Parameter-setting controls

Adjust the parameters in the following four modes:

- When a user-modify effect is selected, these controls, F1 through F4, set the parameters for the effect. Parameters to be set depend on the user-modify effect you select, and some controls cannot be used for some effects. When you turn a control which cannot be used, a warning sound is heard.
See "Parameters for Modifying Effect Patterns" on page A-11.
- In edit mode of the linear-type user-program effects, these controls set the parameters for these user-program effects. The controls from left to right adjust the X-axis rotation (ROT (X)), the Y-axis rotation (ROT (Y)), the Z-axis rotation (ROT (Z)), and perspective (PERS) respectively.
- In edit mode of the non-linear-type user-program effects, these controls set the parameters for these user-program effects. The controls from left to right adjust the degree of modification (OFFSET), type of modification (FORM), Z-axis rotation (ROT (Z)) and angle of effect (ANGLE) respectively.
- When you press one of the mask-adjustment mode on/off buttons 2, these controls adjust the area for the title or downstream-key mask. The controls from left to right adjust the left, right, top and bottom respectively.

8 EDGE section

This section consists of the buttons and control to adjust the edge between the foreground picture and background picture.

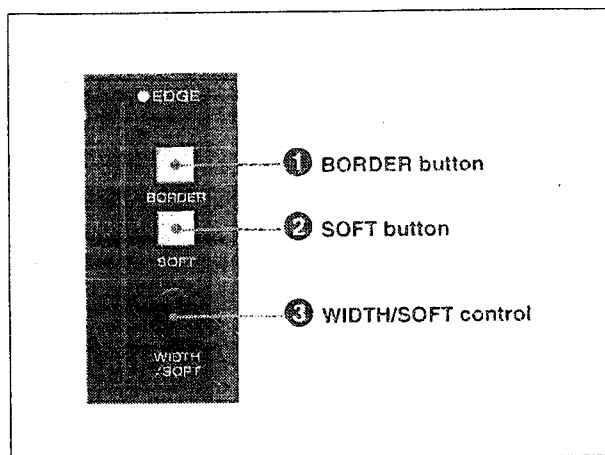

EDGE section

1 BORDER button

Press to add a border line on the edge between the foreground picture and background picture, and the indicator of the button lights. Pressing the button again makes the indicator of the button go out, and the border line disappears.

2 SOFT button

Press to make the edge between the foreground picture and background picture blur, and the indicator of the button lights. Pressing the button again makes the indicator of the button go out, and the edge becomes sharp again.

3 WIDTH/SOFT control

Adjusts the width of the border line or the softness of the edge.

Notes

- A border line and soft edge cannot be used simultaneously.
- A border line or soft edge cannot be added on some effects. When you press the BORDER button or SOFT button with such an effect selected, a warning sound is heard. See "Adjustable Parameters" on page A-8.

9 LOCATION section

This section consists of a button, control and joystick to move the position of an effect pattern.

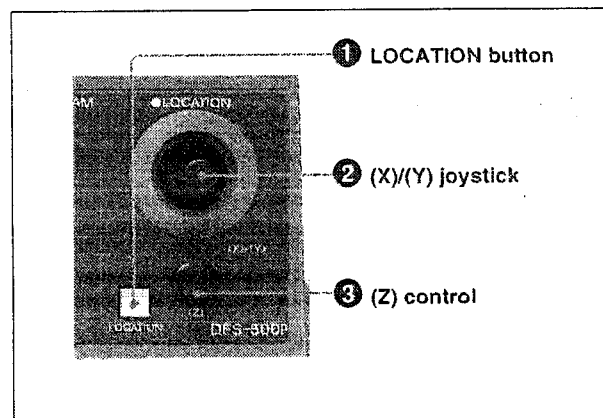

LOCATION section

1 LOCATION button

Press to activate the (X)/(Y) joystick 2 and (Z) control 3, and the indicator of the button lights. Pressing the button again makes the indicator of the button go out, and the (X)/(Y) joystick and (Z) control are disabled, and the position of the selected effect pattern is reset.

Note

When you select an effect pattern whose position cannot be moved, and you press the LOCATION button, the indicator of the button does not light and a warning sound is heard. See "Adjustable Parameters" on page A-8.

2 (X)/(Y) joystick

Moves the effect pattern horizontally (X-axis direction) or vertically (Y-axis direction).

3 (Z) control

Moves the effect pattern in the direction of depth of the screen (Z-axis direction), and changes the size of the pattern.

Note

When you move the (X)/(Y) joystick 2 or (Z) control 3 when they are disabled, a warning sound is heard.

Control Panel

10 SNAP SHOT section

This section consists of the buttons to operate the snap shot function with which settings on the control panel are stored in memory. Up to 100 kinds of settings can be stored in snap shot registers 0 through 99.

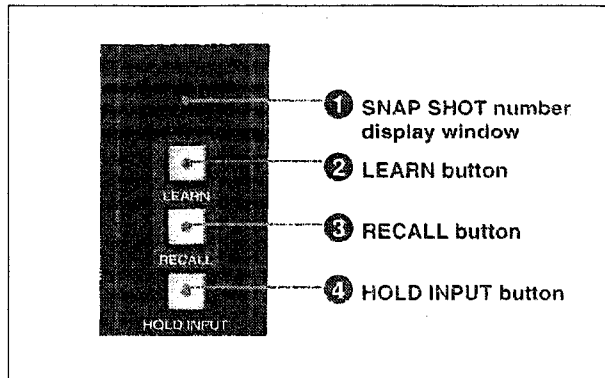

SNAP SHOT section

1 SNAP SHOT number display window

Shows the snap-shot register number, 0 through 99. While entering the number, dots light at the lower right of the digits.

2 LEARN button

Press to store the various settings in the snap shot registers (snap shot learn mode), and the indicator of the button lights.

Enter any number from 0 to 99 using the numeric buttons in the keypad section [3] and press the ENTER button. Then the current settings on the control panel are stored in register of the designated number. When the settings are stored, the indicator of the button goes out and snap shot learn mode is released.

3 RECALL button

Press to recall the settings stored in the snap shot registers (snap shot recall mode), and the indicator of the button lights.

Enter the snap-shot register number to be recalled using the numeric buttons in the key pad section [3], and press the ENTER button. The settings stored in the designated register are recalled at the control panel. When the settings are recalled, the indicator of the button goes out and snap shot recall mode is released.

4 HOLD INPUT button

Press to retain the settings of the primary crosspoint bus section [1] (selected pictures) in snap shot recall mode (hold input mode), and the indicator of this button lights. While the indicator is lit, the input signal does not change in snap shot recall mode. When the data stored in a snap shot register is recalled, settings stored in the designated registers except for those in the primary crosspoint bus section are recalled at the control panel. Pressing the button again makes the indicator of the button go out and hold input mode is released.

11 LIGHTING section

This section consists of the buttons to add lighting effects to a foreground picture.

To use the lighting functions, a BKDF-501/501P trail and lighting board (optional) is necessary.

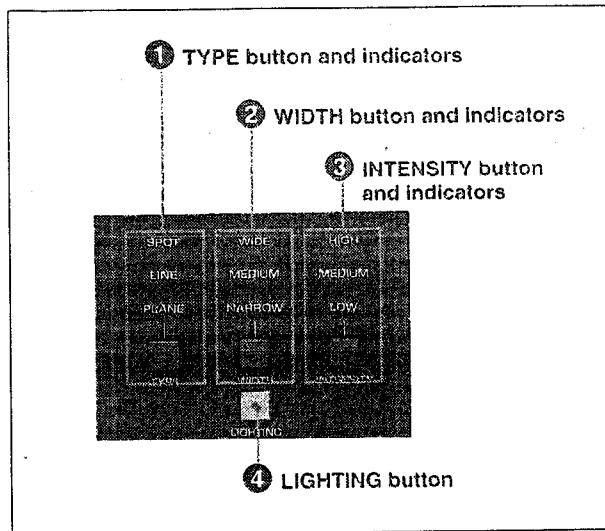

LIGHTING section

1 TYPE (lighting-type select) button and indicators

Selects a type of lighting. Every time the button is pressed, spotlighting, line lighting or plane lighting is selected alternately, and the corresponding indicator lights.

SPOT: Spotlighting

LINE: Line lighting

PLANE: Plane lighting

Note

Types of lighting to be selected depends on the effect pattern.

2 WIDTH (lighting-width select) button and indicators

Selects the width of lighting. Every time the button is pressed, wide lighting, normal-width lighting or narrow lighting is selected alternately.

WIDE: Wide lighting

MEDIUM: Normal-width lighting

NARROW: Narrow lighting

3 INTENSITY (lighting-luminance select) button and indicators

Selects the luminance of lighting. Every time the button is pressed, high luminance, medium luminance or low luminance is selected alternately.

HIGH: High luminance

MEDIUM: Medium luminance

LOW: Low luminance

4 LIGHTING button

Press to turn lighting effects on, and the indicator of the button lights. Pressing the button again turns off the lighting effect and makes the indicator of the button go out.

Note

When you select an effect pattern to which lighting effects cannot be added, and you press the LIGHTING button, a warning sound is heard.

For effect patterns to which lighting effects cannot be added, see "Adjustable Parameters" on page A-8.

Control Panel

12 TRAIL/SHADOW section

This section consists of the buttons and control to make the required settings for trail, drop border and shadow functions, which add optional effects to a foreground picture.

To use these functions, a BKDF-501/501P trail and lighting board (optional) is necessary.

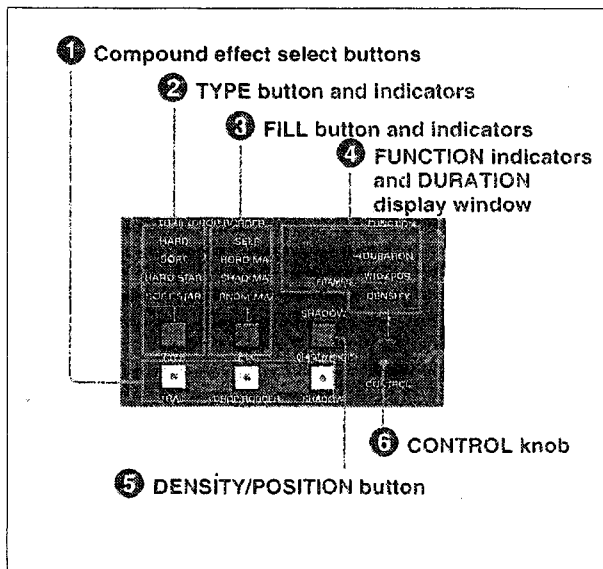

TRAIL/SHADOW section

1 Compound effect select buttons

Press to select a compound effect, and the indicator of the pressed button lights. Pressing the button again makes the indicator of the button go out, and the effect turns off.

TRAIL button: An effect which adds trail to the moving effect pattern

DROP BORDER button: An effect which adds a border behind the selected effect pattern

SHADOW button: An effect which adds shadow to the effect pattern

Notes

- Compound effects above cannot be added to some effect patterns. When you press the compound effect select button with such an effect selected, a warning sound is heard. *For effect patterns to which compound effects cannot be added, see "Adjustable Parameters" on page A-8.*
- Trail, drop-border and shadow effects cannot be added simultaneously.

2 TYPE (trail/drop-border type select) button and indicators

Selects the type of trail or edge of a drop border. Every time the button is pressed, hard, soft, hard star or soft star is selected alternately, and the corresponding indicator lights.

HARD: The trail disappears quickly, or the edge of the drop border is hard.

SOFT: The trail disappears slowly, or the edge of the drop border is soft.

HARD STAR: The trail or the edge of drop border is the same as that of HARD and a stardust effect is added.

SOFT STAR: The trail or the edge of drop border is the same as that of SOFT and a stardust effect is added.

3 FILL (fill-signal select) button and indicators

Selects a signal which fills the inside of the trail or drop border. Every time the button is pressed, a foreground picture (self), border matte, shadow matte or random matte is selected alternately and the corresponding indicator lights.

SELF: The foreground picture

BORD MAT: Border matte

SHAD MAT: Shadow matte

RNDM MAT: Random matte which changes color at random

4 FUNCTION indicators and DURATION display window

Show the parameter for a compound effect selected with the compound effect select button 1 and DENSITY/POSITION button 5. The parameter corresponding to the lit indicator can be set with the CONTROL knob 6.

DURATION: The duration of the trail. On the left window, the set duration appears in units of frames.

WID/POS: The width and position of the drop border, or the position of the shadow is set.

DENSITY: The density of the shadow. When a shadow effect is selected, select WID/POS or DENSITY with the DENSITY/POSITION button.

5 DENSITY/POSITION button

Press to select a parameter for a shadow effect when the indicator of the SHADOW button is lit.

Parameters can be set with the CONTROL knob

6. Every time the button is pressed, DENSITY or WID/POS of the shadow is selected alternately.

6 CONTROL knob

Adjusts the parameter corresponding to the lit FUNCTION indicator 4

13 USER PROGRAM section

This section consists of the button and display windows used to create or edit a user-program effect (user-program edit mode). In this mode, users can make up their own effects. For editing a user-program effect, the keypad section 3 and EFFECT CONTROL section 7 are also used.

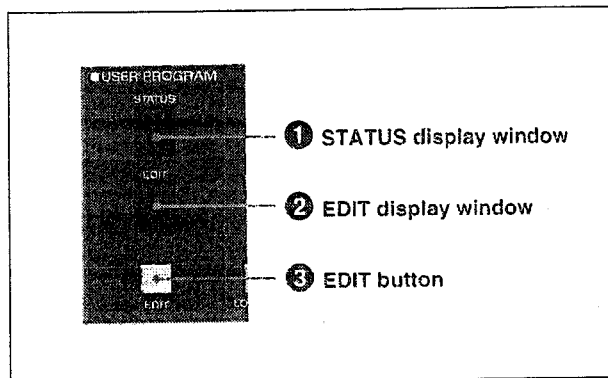

USER PROGRAM section

1 STATUS display window

Shows the number of key frames (up to eight) which the selected effect consists of when you select a user-program effect.

2 EDIT (edit number) display window

Shows the key-frame number which can be edited in user-program edit mode.

3 EDIT button

Press to activate user-program edit mode, and the indicator of the button and the USER PGM indicator in the keypad section 3 light to indicate that user-program edit mode is selected.

Pressing the button again makes the indicator of the button go out, and user-program edit mode is released.

Note

When an effect pattern other than a user-program effect is selected, user-program edit mode cannot be selected even if you press the EDIT button, and a warning sound is heard.

14 EDITOR ENABLE button

Press to enable a connected editing control unit or switcher to control the DFS-500/500P, and the indicator of the button lights. Pressing the button again makes the indicator of the button go out and disables control from the editing control unit or switcher.

15 25-pin connector (on the rear)

Connect to the CONTROL PANEL connector on the processor unit using the supplied 25-pin remote control cable.

Processor Unit

Rear Panel

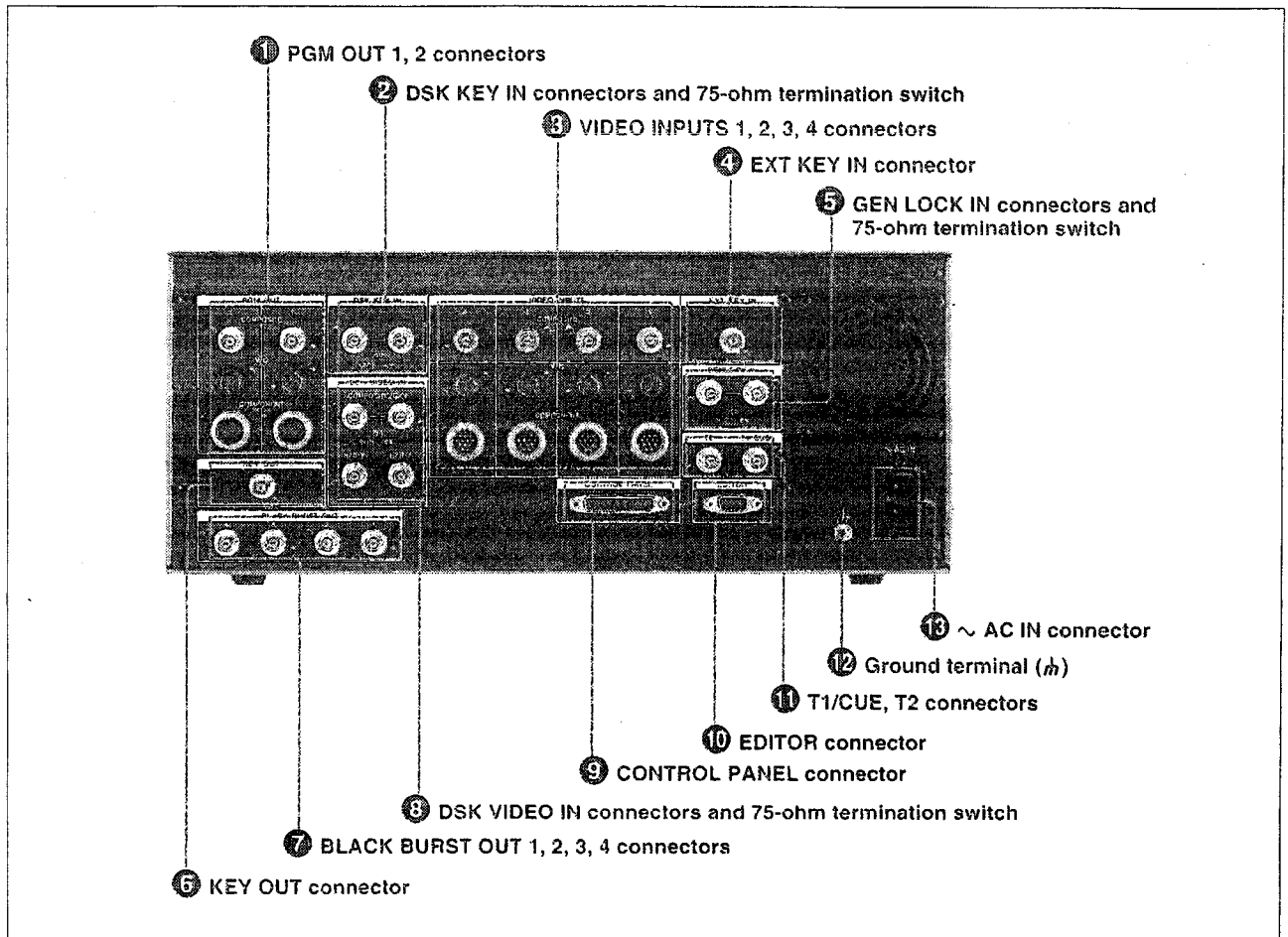

Rear panel

1 PGM OUT (program output) 1, 2 connectors

Output a final picture created with this switcher (a program picture). Connect to the video input connectors on recorder VTRs or a program monitor.

COMPOSITE connectors (BNC type):

Output the composite video signals.

Y/C connectors (4-pin):

Output the S-video (Y/C separate) signals.

COMPONENT connectors (12-pin):

Output the Betacam-format component video signals.

Signals in three different formats can be output simultaneously from these connectors, and the 1 and 2 connectors output the same signals.

2 DSK KEY IN (downstream-key signal input) connectors (BNC type) and 75-ohm termination switch

Input a key-source signal for a downstream key. Connect to an external key-output connector on a character generator. When an external signal is used as a key-source signal (the indicator of the EXT KEY button in the DOWNSTREAM KEYSER section on the control panel is lit), the signal input to this connector is used. If this signal is not used, the signal input to the DSK VIDEO IN connector 3 is used as the key-source signal.

When both connectors are used for a bridging connection, set the 75-ohm termination switch to OFF, and when only one of these connectors is used, set it to ON.

③ VIDEO INPUTS 1, 2, 3, 4 connectors

Input a video signal from a video camera or a player VTR.

COMPOSITE connectors (BNC type):

Input the composite video signals.

Y/C connectors (4-pin):

Input the S-video (Y/C separate) signals.

COMPONENT connectors (12-pin):

Input the Betacam-format component video signals.

Format of the input signal is selected with the input signal-format select switch on the internal board in the processor unit for each connector 1, 2, 3 or 4.

Signals in different format can be input to the 1, 2, 3 and 4 connectors.

④ EXT KEY IN (external-key signal input) connector (BNC type)

Input a key-source signal for title mode. Connect to an external key-signal output connector on a character generator, etc. When an external signal is used as the key-source signal (the indicator of the EXT KEY button in the TITLE section on the control panel is lit), the signal input to this connector is used. If the external signal is not used, the signal input to the VIDEO INPUTS connectors ③ is used as the key-source signal.

⑤ GEN LOCK IN (gen lock input signal) connectors and 75-ohm termination switch

Input an external reference signal (black-burst signal) when this unit operates in external sync mode.

When both connectors are used for bridging connection, set the 75-ohm termination switch to OFF, and when only one of these connectors is used, set it to ON.

⑥ KEY OUT (key-source signal output) connector (BNC type)

Outputs the signal which corresponds to the picture frames of the selected effects as the key-source signal while executing the effect. Connect this connector to the external key input connector of the switcher such as the BVS-3000. In title mode (the indicator of the TITLE button in the TITLE section on the control panel is lit), a key-source signal corresponding to the characters or figures (title) is output.

⑦ BLACK BURST OUT (black-burst signal output) 1, 2, 3, 4 connectors (BNC type)

Output a black-burst signal generated by the built-in sync signal generator.

When an external sync signal is input to the GEN LOCK IN connector ⑤, a black-burst signal synchronized with the external sync signal is output.

When an optional BKDF-502/502P DSK board is installed in this unit, use the signal output from these connectors as a reference sync signal for the signal source for a board such as a character generator.

To improve editing accuracy, supply the black burst signal to the VTRs, editing control unit, etc. for the synchronized operation.

⑧ DSK VIDEO IN (downstream-key video-signal input) connectors and 75-ohm termination switch

Input a fill signal for a downstream key which fills the hole cut with the key-source signal. Input a composite video signal or component video signal (Betacam-format luminance signal and color-difference signal, or RGB signal).

COMPOSITE/G/Y connectors (BNC type):

Input the composite video signal, G signal or Y (luminance) signal.

B/B-Y connector (BNC type):

Input the blue or color-difference (B-Y) signal.

R/R-Y connector (BNC type):

Input the red or color-difference (R-Y) signal.

The signal format is selected with the DSK VIDEO SELECT switch on the DA-63 board in the processor unit according to the input signal.

When a composite video signal is input to this connector, the other COMPOSITE/G/Y connector is used as a loop-through output connector to supply a key-fill signal to the other video equipment. When both connectors are used, set the 75-ohm termination switch to OFF, and when only one of these connectors is used, set it to ON.

When the signal input to the DSK KEY IN connector ② is not used, the luminance signal of the key-fill signal input to this connector is used as the key-source signal.

⑨ CONTROL PANEL connector (25-pin)

Connect to the 25-pin connector of the control panel with the supplied 25-pin remote control cable.

Processor Unit

⑩ EDITOR connector (9-pin)

Connect to the 9-pin remote connector on the editing control unit with the 9-pin remote control cable. Then you can control the DFS-500/500P from an editing control unit such as a BVE-900-series editing control unit or BVS-3000-series video switcher.

⑪ T1/CUE (trigger 1/cue), T2 (trigger 2) connectors (BNC type)

Input a trigger signal to start the effect when executing automatic editing in combination with an editing control unit such as the RM-450, BVE-600. Connect to the cue-output or trigger-output connector of the editing control unit.

For editing using a GPI signal, input the GPI signal to the T1/CUE connector. When another GPI signal is input to the T2 connector, downstream key can be turned on using this signal.

⑫ Ground terminal (♁)

Connect to the ground line if necessary.

⑬ ~ AC IN connector

Connect to an AC outlet using the supplied power cord.

Front Panel and Internal Boards

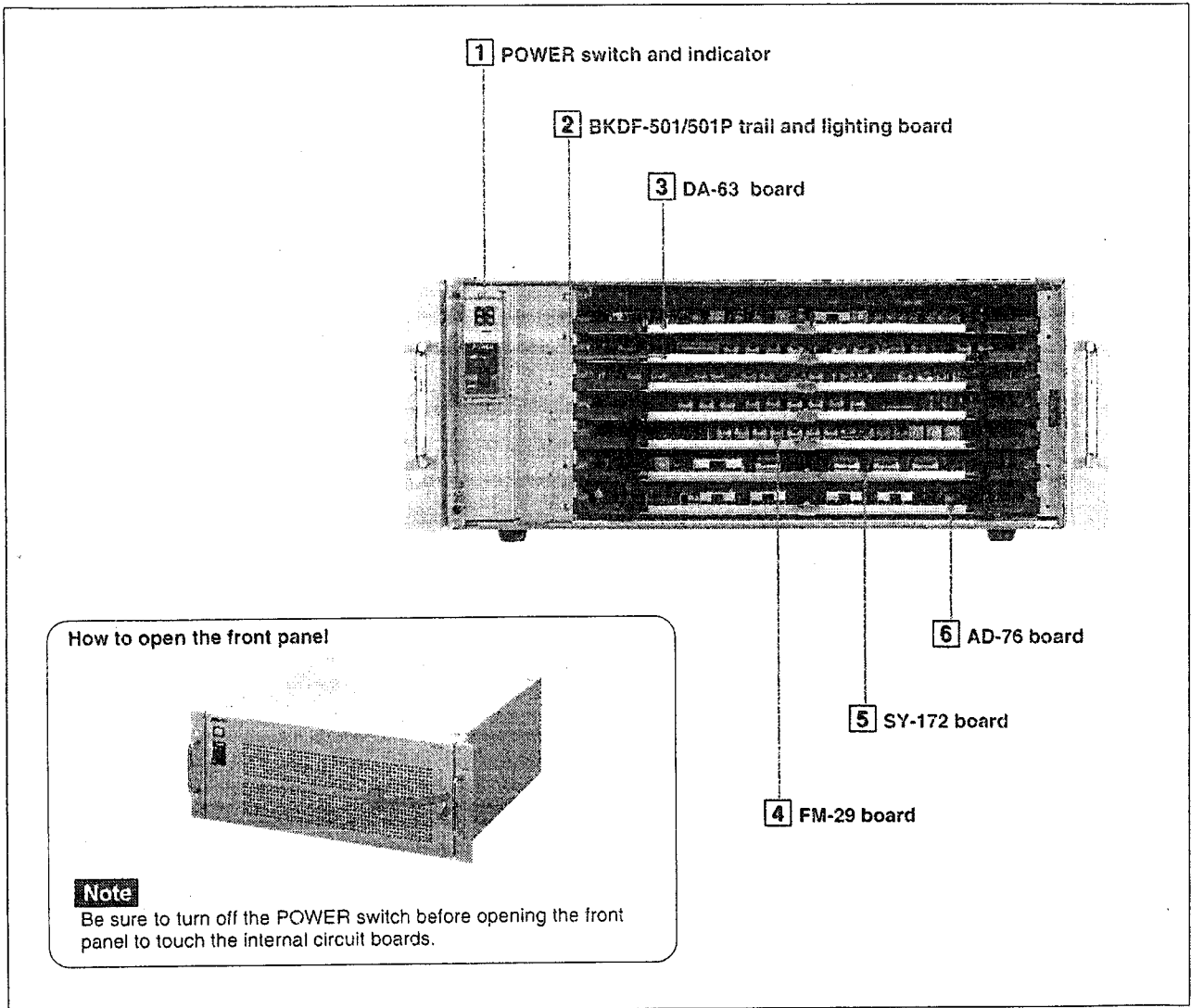

Front panel and internal board

1 POWER switch and indicator

Turn the power ON and OFF. When the power is turned on, the indicator lights.

2 BKDF-501/501P trail and lighting board (optional)

This board is an optional board to add trail, lighting and shadow effects.

Processor Unit

3 DA-63 (D/A converter) board

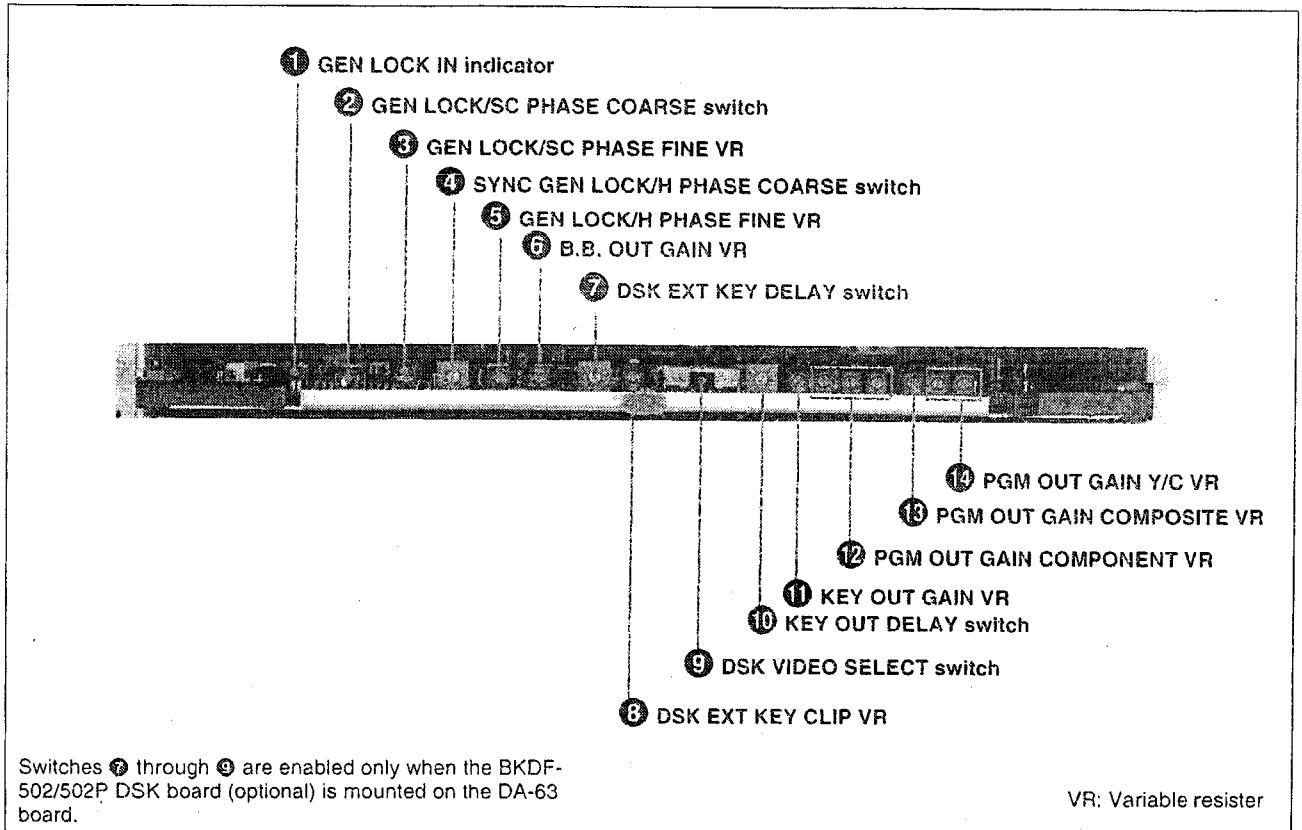

DA-63 board

1 GEN LOCK IN (external sync signal input) indicator

Indicates whether an external sync signal (black-burst signal) is input to the GEN LOCK IN connector on the rear panel.

Lit in red: Indicates that an external sync signal is input. The built-in sync signal generator will be automatically synchronized with the input external sync signal (gen lock mode).

Not lit: Indicates that no external sync signal is input. The built-in sync signal generator generates the sync signal independently (internal sync mode).

2 GEN LOCK/SC PHASE COARSE (sync-signal subcarrier phase coarse adjustment) switch

Roughly adjusts the subcarrier phase of a sync signal generated by the built-in sync-signal generator, which will lock with the external reference sync signal, with respect to that of the reference sync signal input to the GEN LOCK IN connector on the rear panel.

Changing the setting reverses the subcarrier phase by about 180°.

Set the switch to the opposite position when the phases of the two sync signals do not match using the SC PHASE FINE control 3.

3 GEN LOCK/SC PHASE FINE (sync-signal subcarrier-phase fine adjustment) VR

Adjusts the subcarrier phase of the sync signal generated by the built-in sync signal generator precisely so that it matches that of the reference sync signal input to the GEN LOCK IN connector on the rear panel.

④ GEN LOCK/H PHASE COARSE (sync-signal horizontal-phase coarse adjustment) switch

Adjusts the horizontal phase of the sync signal generated by the sync-signal generator roughly so that it matches that of the reference sync signal input to the GEN LOCK IN connector on the rear panel.

The phase can be adjusted in 16 steps of about 280 ns per step.

⑤ GEN LOCK/H PHASE FINE (sync-signal horizontal-phase fine adjustment) VR

Adjusts the horizontal phase of the sync signal generated by the sync-signal generator precisely after adjusting the phase with the GEN LOCK/H PHASE COARSE switch ④.

⑥ B.B. OUT GAIN (black-burst signal-output gain) VR

Adjusts the signal level output from the BLACK BURST OUT 1 through 4 connectors on the rear panel. The adjustable range is about ± 3 dB.

⑦ DSK EXT KEY DELAY (external downstream-key delay) switch

Adjusts the amount of delay of the signal input to the DSK KEY IN connector (external key-source signal for downstream key) on the rear panel with respect to the signal input to the DSK VIDEO IN connector (key-fill signal for downstream key).

The delay can be adjusted in 16 steps of about 70 ns per step.

⑧ DSK EXT KEY CLIP (external downstream-key signal clipping level) VR

Adjusts the clipping level of a key-source signal when a signal input to the DSK KEY IN connector is used as the key-source signal for a downstream key.

⑨ DSK VIDEO SELECT (signal format of a key-fill signal for downstream key select) switch

Set this switch according to the format of the key-fill signal input to the DSK VIDEO IN connector on the rear panel.

COMPOSITE: When a composite video signal is input

Y/R-Y/B-Y: When Betacam-format luminance (Y) and color-difference (R-Y/B-Y) signals are input

R/G/B: When the RGB signals are input (factory setting)

⑩ KEY OUT DELAY (output key-signal delay) switch

Adjusts the amount of delay of the signal output from the KEY OUT connector with respect to the signal output from the PGM OUT connectors.

The delay can be adjusted in 16 steps of about 70 ns per step.

⑪ KEY OUT GAIN (output key-signal gain) VR

Adjusts the signal level output from the KEY OUT connector.

The adjustable range is about ± 3 dB.

⑫ PGM OUT GAIN COMPONENT (program output component-signal level) VR

Adjusts the level of the component video signal (Y/R-Y/B-Y) output from the 12-pin PGM OUT connectors. The adjustable range is about ± 3 dB. The VRs from the left to right adjust the Y signal, R-Y signal and B-Y signal respectively.

⑬ PGM OUT GAIN COMPOSITE (program output composite-signal level) VR

Adjusts the level of the composite video signal output from the BNC-type PGM OUT connectors. The adjustable range is about ± 3 dB.

⑭ PGM OUT GAIN Y/C (program output Y/C-signal level) VR

Adjusts the level of the Y/C signal output from the 4-pin PGM OUT connectors. The left VR adjusts the Y signal, and the right the C signal. The adjustable range is about ± 3 dB.

Processor Unit

4 FM-29 (frame synchronizer) board

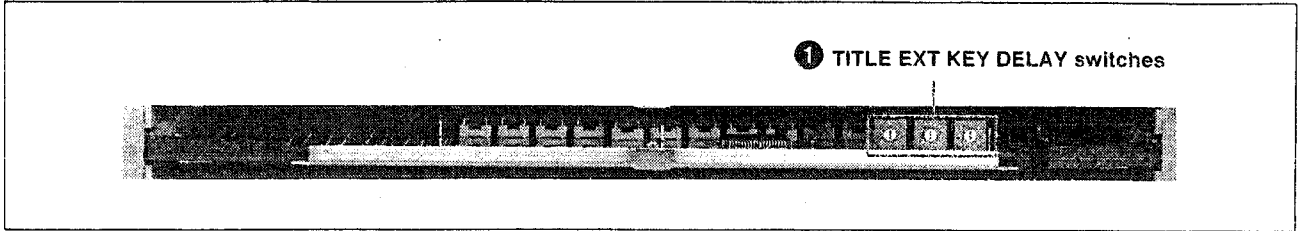

FM-29 board

1 TITLE EXT KEY DELAY (external title-key delay control) switches

Adjust the amount of delay of a key-source signal with respect to a key-fill signal when a signal input to the EXT KEY IN connector on the rear panel is used as the key-source signal for superimposing a title.

COARSE switch (left): Adjusts the amount of delay in 8 steps (from 0 through 7, or from 8 through F) of about 17.8 μ s per step. (Settings for 0 through 7 and 8 through F are the same.)

MID switch (center): Adjusts the amount of delay in 16 steps of about 1120 ns per step.

FINE switch (right): Adjusts the amount of delay in 16 steps of about 70 ns per step.

Note

The amount of delay of the signal input to the EXT KEY IN connector should be adjusted according to the format of the input video signal (composite, Y/C or component). The composite signal should be delayed more than 1 line (63.5 μ s) with respect to the Y/C or component signal.

5 SY-172 (system control) board

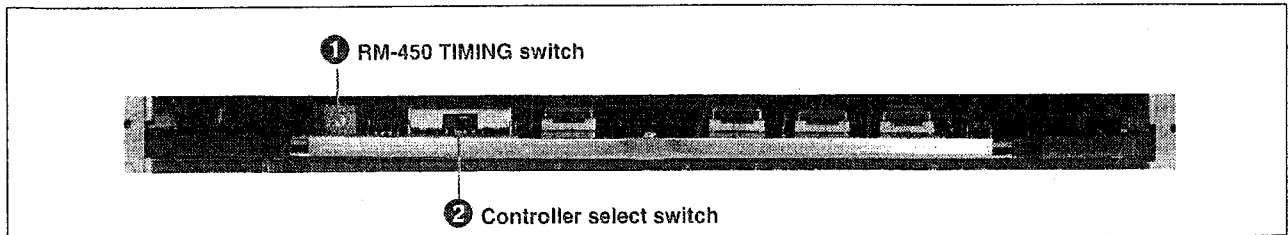

SY-172 board

1 RM-450 TIMING (RM-450 freeze timing) switch

Adjusts the timing of the freeze in point of a background picture (the point to freeze the background picture) against the In point when editing in combination with the RM-450 editing control unit.

Turning the switch in the + direction (9, A... F) delays the timing of the freeze in point, and in the - direction (7, 6 ... 0) advances the timing. The adjustable range is -8 to +7 fields in units of fields. At the factory, the switch is set to 8.

2 Controller select (editing control unit select) switch

Set this switch according to the connected editing control unit or video switcher.

BVE-600/RM-450: When a BVE-600 or RM-450 editing control unit is connected.

ONE-GPI: When equipment corresponding to the GPI (General Purpose Interface) signal is connected

BVE-900: When a BVE-900-series editing control unit is connected (factory setting). Use this position when no editing control unit is connected to the DFS-500/500P.

BVS-3000: When a BVS-3000 series video switcher is connected.

Note

If the switch setting is changed with the power ON, the setting cannot be changed. Press the POWER switch to turn the power off, then reset the switch.

Processor Unit

6 AD-76 (A/D converter) board

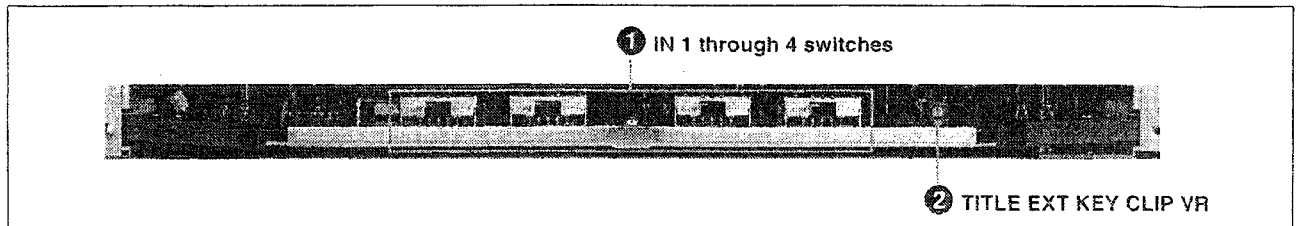

AD-76 board

① IN 1 through 4 (input signal-format select) switches

Select a signal format according to the signal input to the VIDEO INPUTS 1 through 4 connectors on the rear panel respectively.

COMPOSITE (left): When a composite video signal is input

Y/C (center): When a Y/C separate video signal is input

COMPONENT (right): When a Betacam-format, component signal is input

At the factory, switches 1 through 4 are set to COMPOSITE.

② TITLE EXT KEY CLIP (external title-key clipping level) VR

Adjusts the clipping level of the key-source signal when the signal input to the EXT KEY IN connector on the rear panel is used as the key source signal for superimposing a title.

Chapter 3

Preparations

This chapter describes connections and internal switch settings according to your purpose and safety precautions you should be aware of.

Precautions	3-2
Safety Precautions	3-2
Handling Precautions	3-2
Power Connection and Initialization	3-3
Connections	3-5
Basic System Connections	3-5
Key Signal Connections	3-6
A-roll Editing System Connections	3-7
A/B-roll Editing System Connections	3-8
Connections with the BVS-3000	3-10
Settings of the Internal Switches	3-11

Precautions

Safety Precautions

Power Supply

Connect the DFS-500 to a 120 V AC power outlet, or the DFS-500P to a 220 to 240 V AC power line.

Do not drop or place heavy objects on the power cord. If the power cord is damaged, turn off the power immediately. It is dangerous to use the unit with a damaged power cord. Disconnect the power cord from the AC outlet by grasping the plug, not by pulling the cord.

Keep foreign objects out of the cabinet

Dropping flammable or metal objects into the cabinet, or spilling liquids nearby can lead to accidents.

In case of trouble

If you notice an unusual sound, smell or smoke, turn off the power immediately, disconnect the power supply and contact your Sony dealer.

Handling Precautions

Location

Do not store or use the unit under any of the following conditions:

- In excessive heat or cold (permissible temperature range: 5 to 40°C (41 to 104°F).
- In direct sunlight or near heaters. Remember that the temperature inside a locked automobile in summer can rise as high as 50°C (122°F).
- In damp or dusty locations.
- Near vibrations.
- Near strong magnetic fields.
- Near televisions or radios generating strong radio frequency energy.

Protect from impact

Do not drop the unit or subject it to sever shocks.

Keep well ventilated

To keep temperatures from rising inside the unit, keep the unit uncovered and well ventilated while it is in operation.

Maintenance

Clean the cabinet and panels by wiping with a soft, dry cloth.

For severe stains, moisten the cloth with a small amount of neutral solvent, and finish by wiping with a dry cloth. Do not use alcohol, benzene, thinner or volatile liquids, as these may discolor or damage the cabinet surface.

Transporting

Protect from impact by transporting in the supplied carton or a protective case.

Power Connection and Initialization

Power source to be used

The DFS-500 operates on 90 to 132 V AC, 48 to 63 Hz, and the DFS-500P on 180 to 264 V AC, 48 to 63 Hz. Connect the unit to the appropriate power source using the supplied AC power cord.

When the power is supplied for the first time to the DFS-500/500P, the settings at the control panel default to the factory settings. After that, your settings in force when the power is turned off are retrieved when the power is turned on again (resume function).

Backup battery

The DFS-500/500P can retain the data for snap shot which stores the settings on the control panel or user-program effects which the user creates. To retain such data, a backup battery (nickel-cadmium battery) is equipped on the SY-172 board in the processor unit.

Before using the DFS-500/500P for the first time, fully charge the backup battery by continuously supplying the power for about eight hours. If the DFS-500/500P is not used for more than one month, the battery will lose its charge, and your data for items (1) to (4) below will be lost, so the next power-up will retrieve the factory settings. Therefore it is recommended to charge the battery periodically by turning the DFS-500/500P on.

- (1) Resuming user settings when the power is turned off (resume function)
- (2) User-program effects
- (3) Snap shot
- (4) Assignment for direct pattern selection

Replacing the backup battery

The backup battery is guaranteed for about five years under normal operating conditions. Replace the battery as required. Please request battery replacement to the Sony authorized representative.

After replacing the backup battery, continuously supply the power to the DFS-500/500P for about eight hours to charge the battery.

Note

When the backup battery is replaced, the retained data of (1) to (4) mentioned above are lost and the factory settings will be retrieved.

Precautions

Retrieving the factory settings (Initializing the control panel setting)

If an unexpected mode is selected during operation and you lose your steps, the factory setting conditions can be retrieved with the following procedures. Normally you can recall the settings when the power was turned off by turning the power on (resume function).

- 1 If the indicator of the EDIT button in the USER PROGRAM section is lit, press the button to make the indicator go out.
- 2 Press the EDITOR ENABLE button while holding down the RST and DOWN buttons in the keypad section.
A buzzer sounds, and the settings are initialized to the factory settings.

The direct patterns assigned by the user (page 6-3), user-program effects (page 6-19) and snap shot (page 6-23) cannot be initialized with the above procedure. *For initializing these data, see the pages mentioned above in parenthesis.*

Initializing all the data

To initialize all the data, including the direct pattern assignment, user-program effects and snap shot, turn the power on while holding down the RST and DOWN buttons in the keypad section.



Connections

Before connecting any equipment to this unit, be sure to turn the power to the equipment to be connected off.

Basic System Connections

The connections for the essential input and output signals are introduced as follows.

The cable which connects the DFS-500/500P and a VTR depends on the type of the VTR to be connected. Please refer to the instruction manual provided with the VTR.

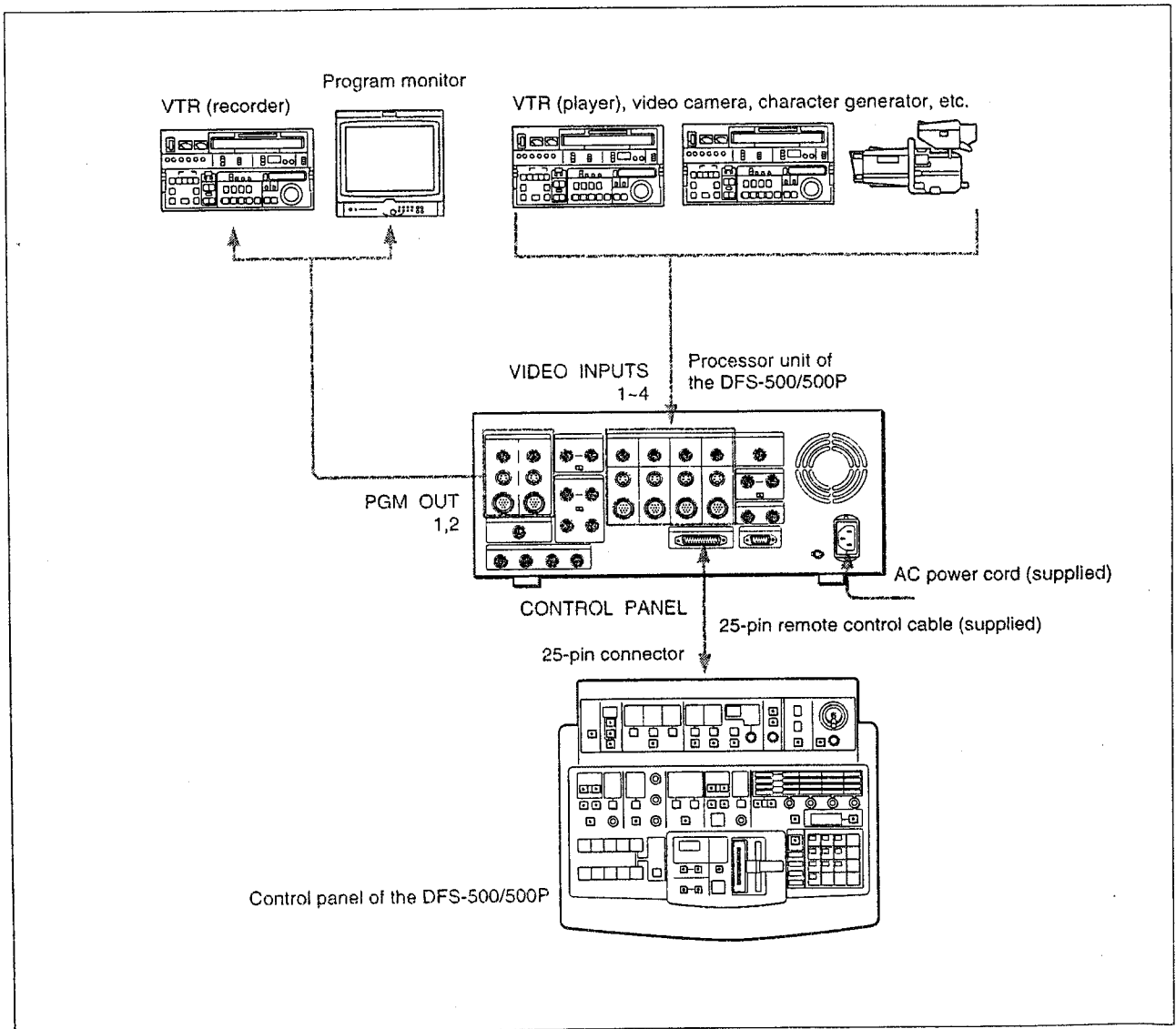

Basic system connections

Connections

Key Signal Connections

These are the connections for key signals for a title key or a downstream key (DSK) for superimposing characters or figures on a picture.

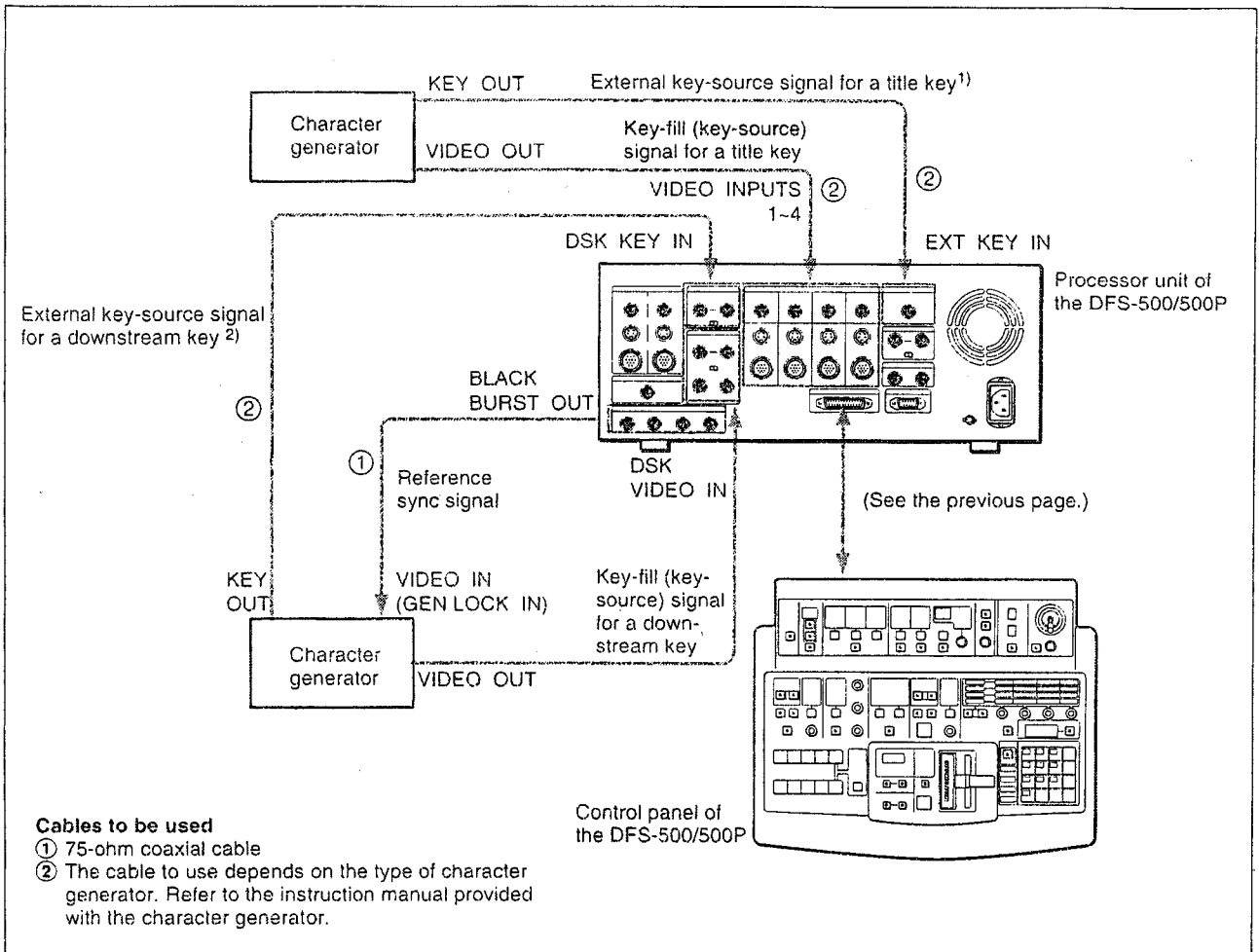

Key signal connections

Notes

- The signal for a downstream key should be synchronized with the internal sync signal of the DFS-500/500P. Be sure to connect the signal output from the BLACK BURST OUT connector to the signal source equipment for the downstream key.
- The key signal for a title key or a downstream key is processed in 1 bit. When the signal played back on a VTR is used as a key-source signal, the outline of the key may be unclear. It is recommended to use a high-quality signal such as that generated by a character generator as a key-source signal for a title key or a downstream key.

1) This connection is unnecessary when the luminance signal of the signal input to the VIDEO INPUTS connector is used as a key-source signal.

2) This connection is unnecessary when the luminance signal of the signal input to the DSK VIDEO IN connector is used as a key-source signal.

A-roll Editing System Connections

When the DFS-500/500P is used in combination with the RM-450 or BVE-600 editing control unit, A-roll editing system which uses two VTRs, one as a player and the other as a recorder, is constructed.

When an editing control unit which supplies a GPI signal is connected, A-roll editing using the GPI signal is also possible.

Note

An RM-440 editing control unit cannot be used with the DFS-500/500P.

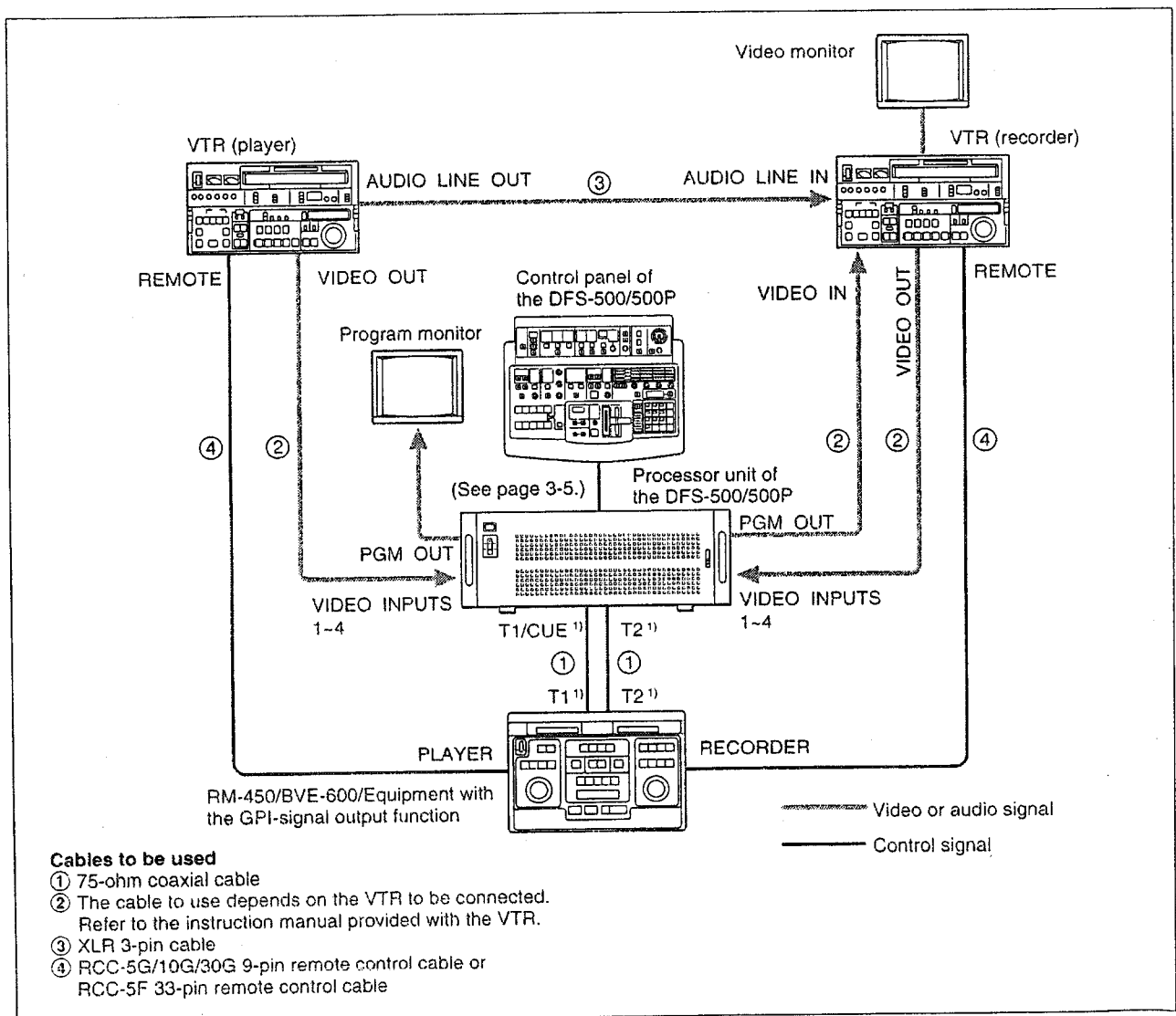

A-roll editing connections

1) Connection with the DFS-500/500P and an editing control unit

When the RM-450 is used: Connect the CUE connector of the RM-450 to the T1/CUE connector of the DFS-500/500P.

When the BVE-600 is used: Connect the T1 and T2 connectors of the BVE-600 to the T1/CUE and T2 connectors on the DFS-500/500P respectively.

When the equipment has a the GPI signal-output function: Connect the GPI output connector to the T1/CUE connector on the DFS-500/500P.

Connections

A/B-roll Editing System Connections

When the DFS-500/500P is used in combination with a BVE-600, BVE-900 or BVE-910 editing control unit, A/B-roll editing system which uses three VTRs, two as players and one as a recorder, is constructed.

With an editing control unit which supplies a GPI signal, A/B-roll editing using the GPI signal is also possible.

Using a GPI signal

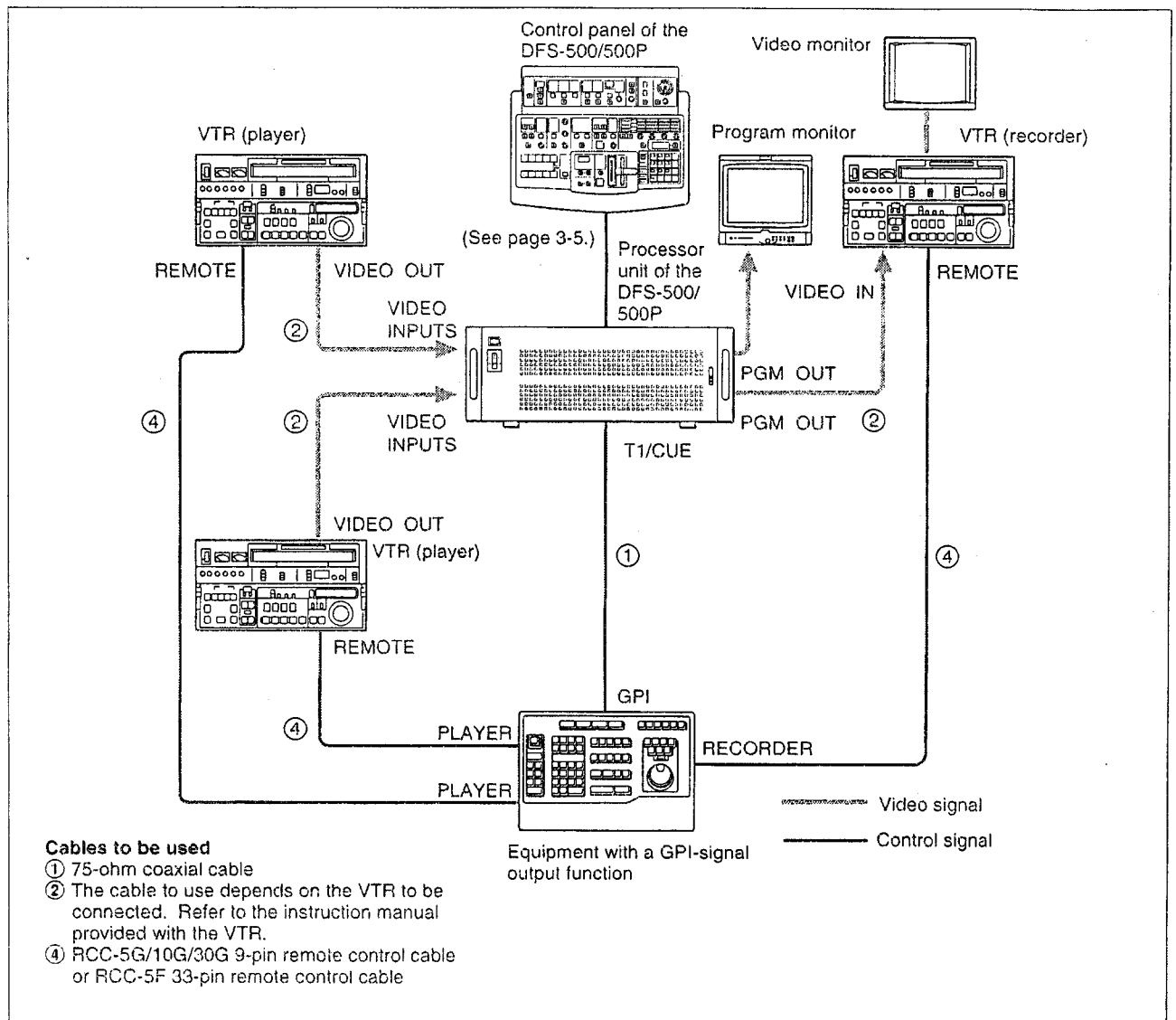

A/B-roll editing system connections (1) – Using a GPI signal

Using a BVE-600/900/910

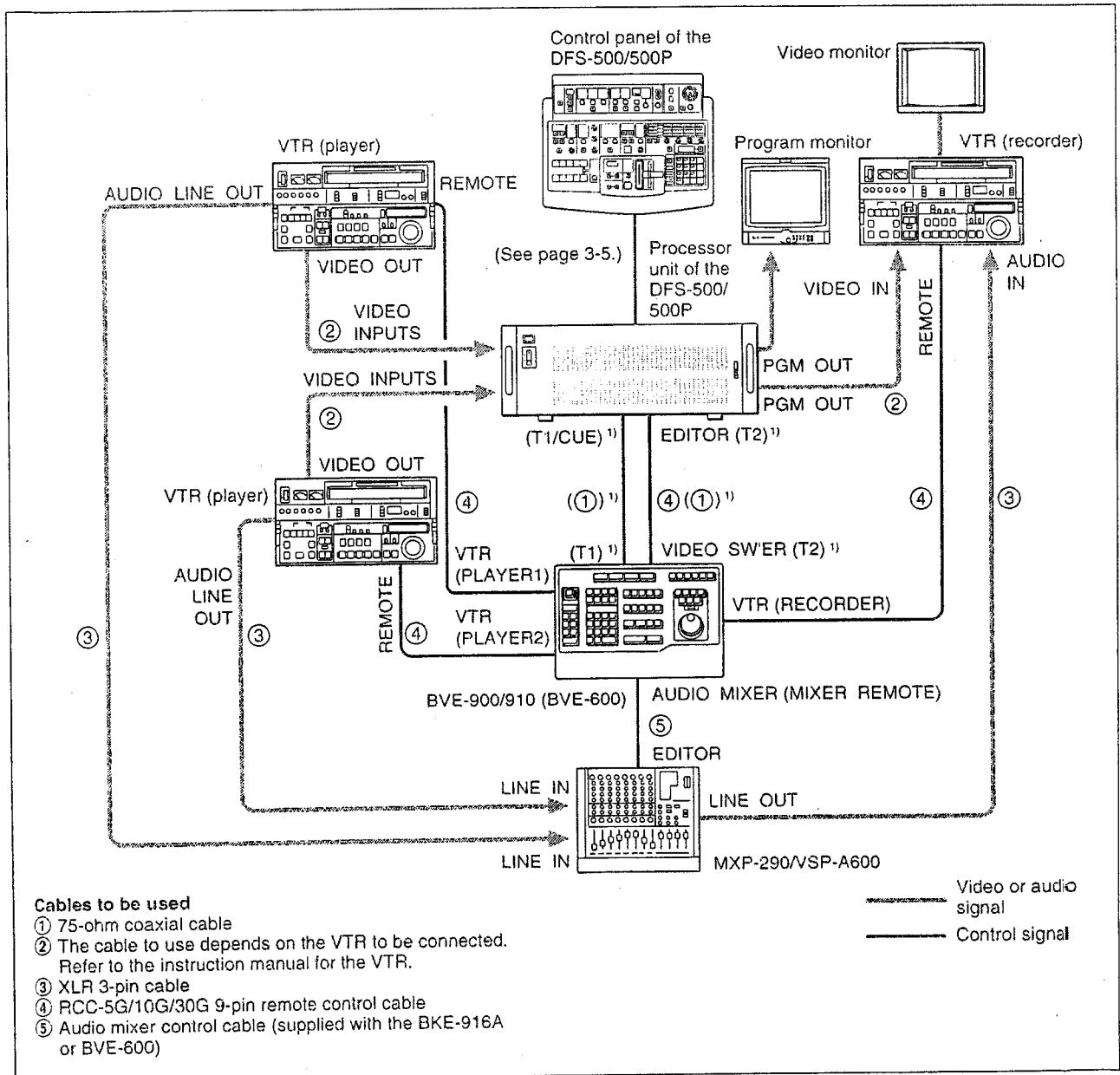

A/B roll editing system connections (2) – Using the BVE-600/900/910

Note

If the BVE-910 is connected to the DFS-500/500P, VTRs, MXP-290 and VSP-A600, the optional interface boards such as a BKE-904, BKE-913, BKE-916A must be installed in the BVE-910.

For details, refer to the instruction manual for the BVE-910.

- 1) Connections with the editing control unit and the DFS-500/500P
When the BVE-900/910 is used: Connect the VIDEO SW'ER connector of the BVE-900/910 to the EDITOR connector on the DFS-500/500P.

When the BVE-600 is used: Connect the T1 and T2 connectors on the BVE-600 to the T1/CUE and T2 connectors on the DFS-500/500P respectively.

Connections

Connections with the BVS-3000

When the DFS-500/500P is used in a BVS-3000 series video switcher system, the effects of this unit can be added to those of the BVS-3000 series.

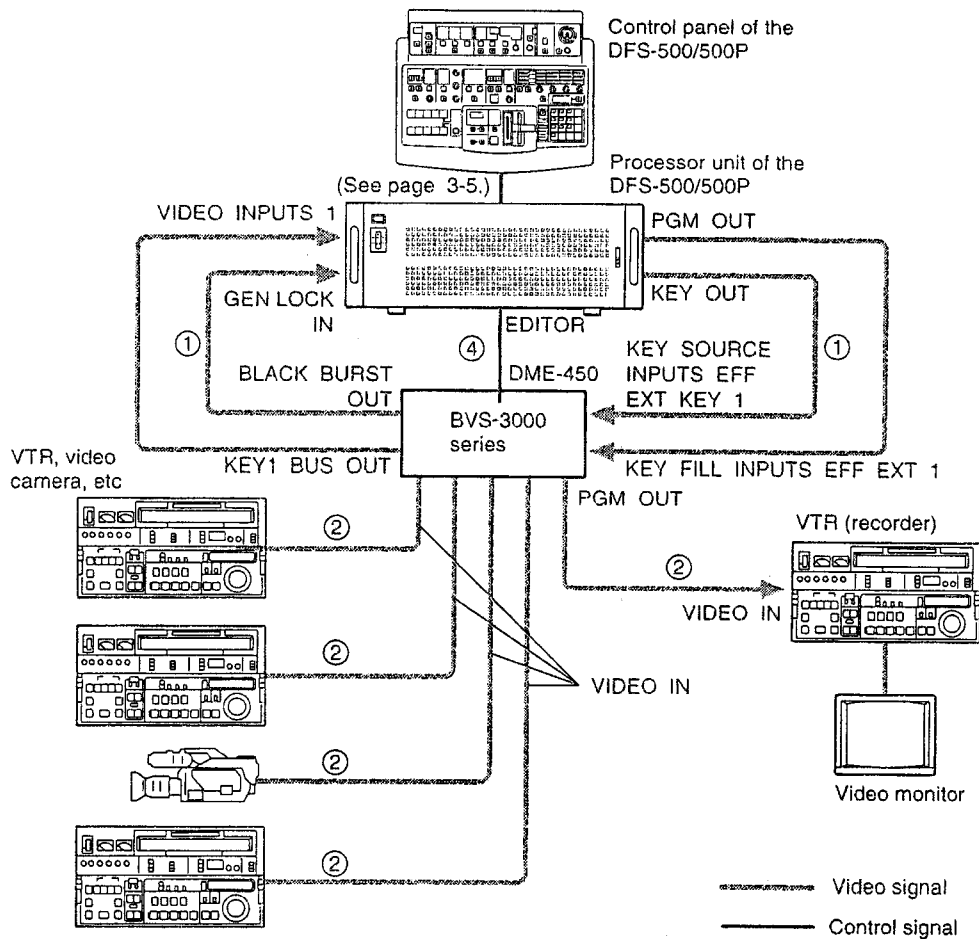

Cables to be used

- ① 75-ohm coaxial cable
- ② The cable to use depends on the VTR to be connected. Refer to the instruction manual for the VTR.
- ④ RCC-5G/10G/30G 9-pin remote control cable

Connections with the BVS-3000

Settings of the Internal Switches

When the connections are completed, set the switches below on the boards in the processor unit according to the connected equipment.

When an editing control unit, video switcher, etc., are used together, adjustments on the connected equipment are also necessary.

See Chapter 7 "Controlling with the Editing Control Unit."

Setting the input signal format: IN 1 to 4 switches (AD-76 board)

Set the switches according to the format of the video signals input to the VIDEO INPUTS connectors respectively.

COMPOSITE: When a composite video signal is input

Y/C: When an S-video signal is input

COMPONENT: When a Betacam-format component signal is input

At the factory, all the switches are set to COMPOSITE.

Setting the control mode: controller select switch (SY-172 board)

Set the switch according to the connected editing control unit or switcher.

BVE-600/RM-450: When a BVE-600 or RM-450 editing control unit is connected

ONE-GPI: When the equipment supporting the GPI (General-Purpose Interface) signal is connected.

BVE-900: When a BVE-900-series editing control unit is connected.

BVS-3000: When a BVS-3000-series video switcher is connected

At the factory, the switch is set to BVE-900. When no editing control unit nor switcher is used, keep the switch to BVE-900, the factory-set position.

Setting the key signal: DSK VIDEO SELECT switch (DA-63 board)

Set this switch according to the format of the signal input to the DSK VIDEO IN connector.

COMPOSITE: When a composite video signal is input

Y/R-Y/B-Y: When a luminance (Y) and color-difference (R-Y/B-Y) signals are input

R/G/B: When RGB signals are input

At the factory, the switch is set to R/G/B.

If adjustment of delay or clipping level of a key signal is required, adjust it with the switches and VRs (variable registers) corresponding to the items to be adjusted.

See "Front Panel and Internal Boards" on page 2-21.

Chapter 4

Introduction to the DME Switcher

This chapter describes basic operation using two types of built-in effects, to familiarize you with a system equipped with the DFS-500/500P. It also explains the demo function which introduces you the most effective editing possibilities using the typical effect patterns.

Flow of Operation	4-2
Basic Operation	4-3
Wipe	4-3
Picture-in-Picture	4-6
Demonstration	4-9

Flow of Operation

The following chart shows the flow of typical operation of the DME switcher. The example on the left shows the basic operation essential for the DME switcher, while that on the right shows advanced operation executed as required. Details of each step are described in Chapter 5.

See the pages indicated in parentheses.

Basic operation

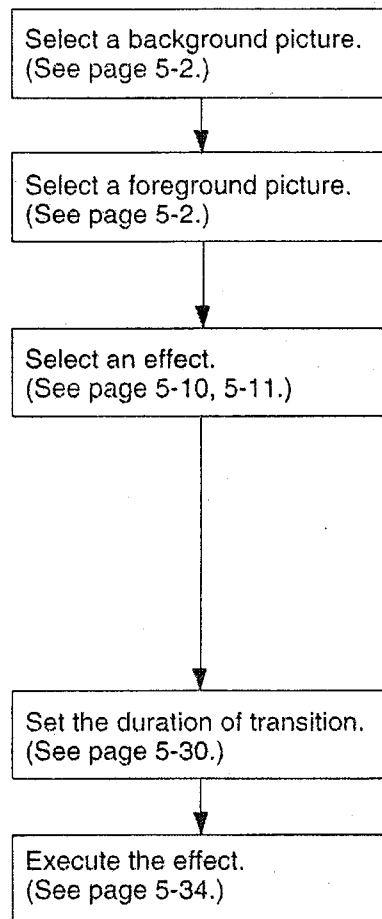

Advanced operation

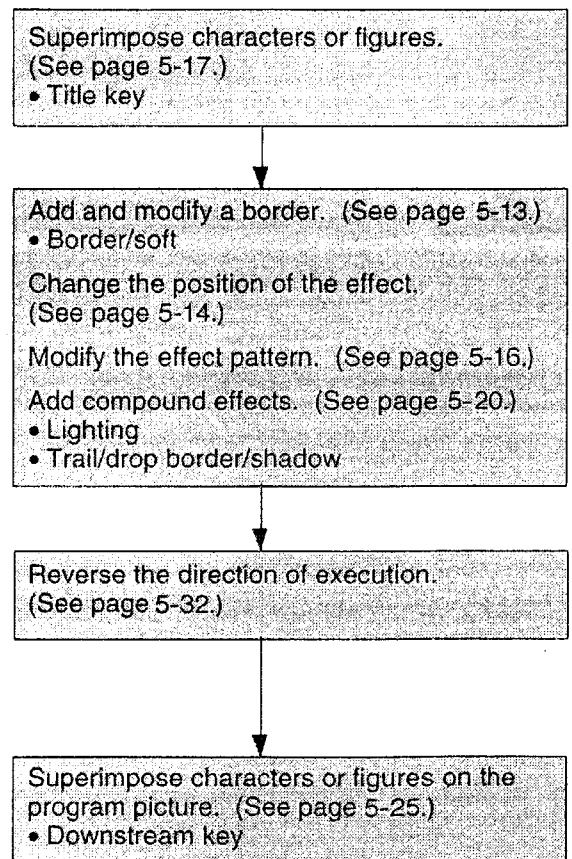

Note

The above procedure is explained supposing that the controller select switch in the processor unit is set to BVE-900. If the switch is set to the position other than BVE-900, the DFS-500/500P may operate in different way from the explanation.

Basic Operation

The flow of operation is introduced here using two typical effects.

Wipe

Wipe a picture from upper left to the lower right to another picture using the AUTO TRANS button.

Items to be set

Set the following four items on the control panel.

The background picture which appears before the effect: A signal input to the VIDEO INPUTS 1 connector for example

The foreground picture which appears after the effect: A signal input to the VIDEO INPUTS 2 connector for example

Effect which is used to change the background picture to the foreground picture: Wipe (pattern number 9) for example

The duration of the transition, which is the period for changing pictures: 30 frames for example

Program picture

While executing the above effect, the picture on the program monitor changes as follows.

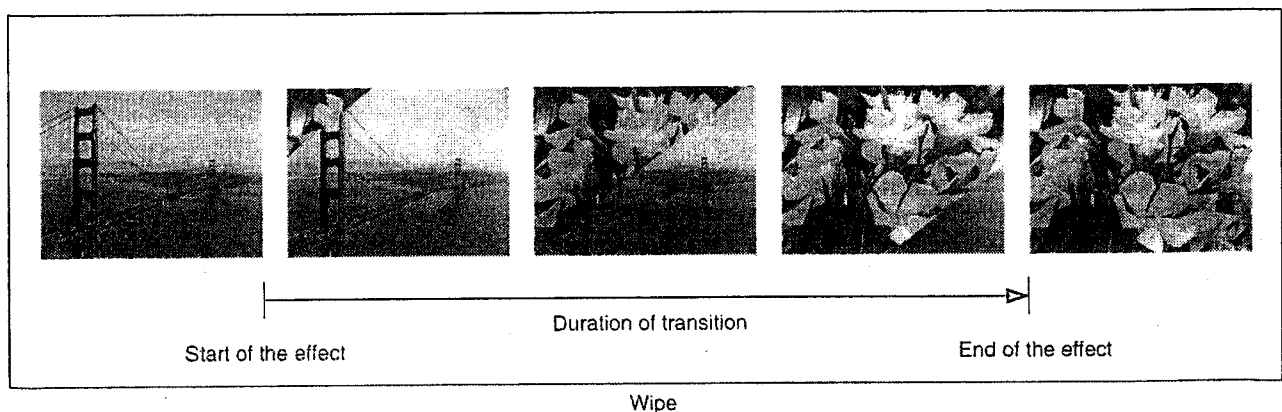

Basic Operation

Operation

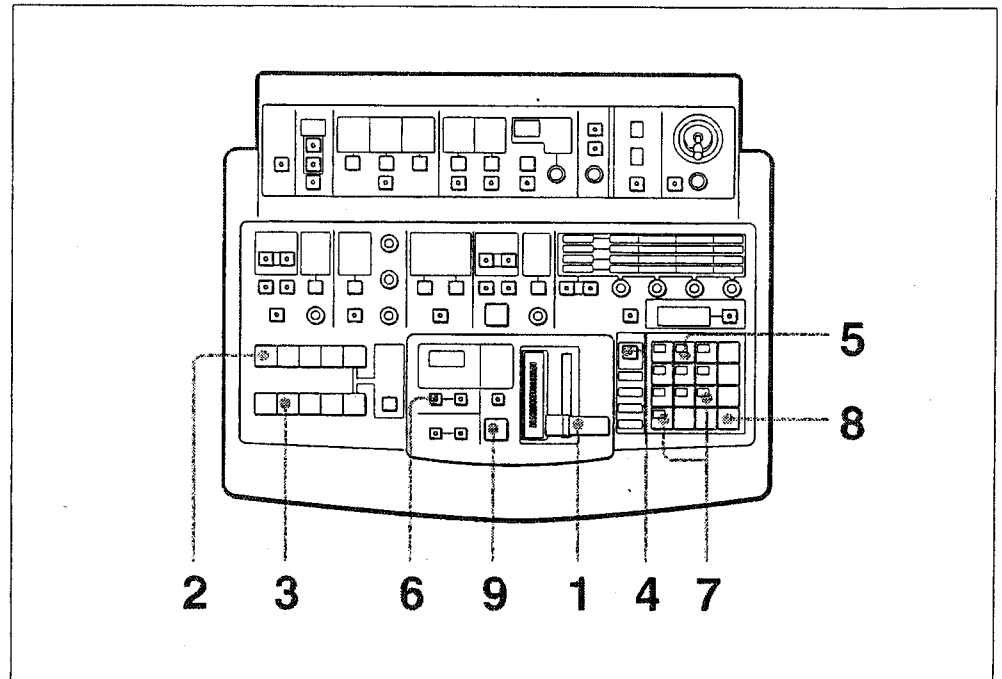

Basic operation (1) – Wipe

Preparation

- 1 Move the fader lever all the way forward.

Picture selection

- 2 Press the BACKGROUND bus button [1].
The pressed button lights in red, and the picture input to the VIDEO INPUTS 1 connector is selected for the background picture.
The selected picture appears on the program monitor screen.

- 3 Press the FOREGROUND bus button [2].
The pressed button lights in amber, and the picture input to the VIDEO INPUTS 2 connector is selected for the foreground picture.
To check the selected picture on the program monitor screen, move the fader lever all the way back. After checking the picture, be sure to return the lever to all the way forward.

Effect selection

- 4 Press the DIRECT PATTERN button to turn on the indicator of the button.
If the indicator is lit, skip this step.
A desired effect can be selected among from the 13 effect patterns assigned on the PATTERN/KEY PAD buttons by pressing the corresponding button (direct pattern select mode).

- 5 Press the PATTERN/KEY PAD button [8].
The pressed button lights, and wipe of pattern 9, which has been assigned to the pressed button is selected. The PATTERN NUMBER display window shows 9.

Duration of the transition setting

- 6** Press the EFFECT button.
The indicator of the button and the EFFECT indicator of the TRANS RATE display window light.
- 7** Press the numeric buttons **3** and **0**.
The TRANS RATE display window shows [.3.0].

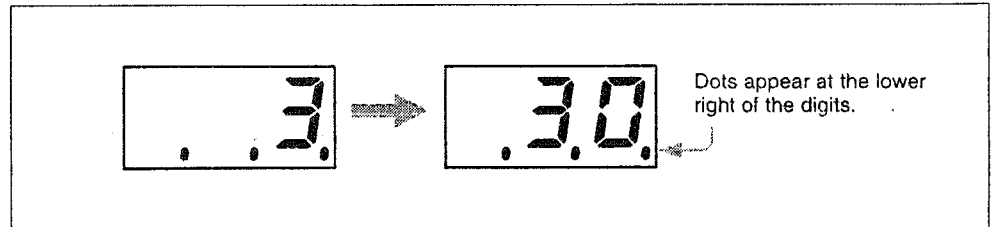

TRANS RATE display window

- 8** Press the ENTER button
The dots disappear, and the value entered in step 7 is set as the duration of the transition.
- 9** Press the AUTO TRANS button.
The background picture is replaced with the foreground picture with a duration of 30 frames for the wipe.
At the end of the transition, the BACKGROUND bus button **2** lights in red instead of the button **1**, and the FOREGROUND bus button **1** lights in amber instead of button **2**.

Effect execution

Basic Operation

Picture-in-Picture

Using the fader lever, insert the foreground picture in the background picture, and add a border around the inserted foreground picture.

Items to be set

Set the following four items at the control panel.

Background picture: A built-in video signal (a color background)

Foreground picture: A picture input to the VIDEO INPUTS 1 connector

Effect: Picture-in-Picture (pattern number 1100)

Border: On

Program picture

When the above effect is executed, the picture on the program monitor screen changes as shown below:

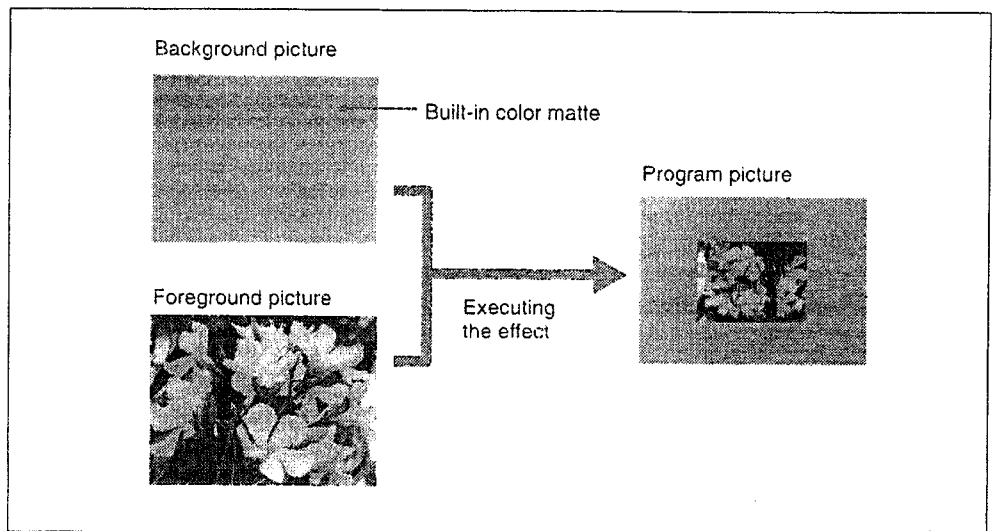

Picture-in-picture

Operation

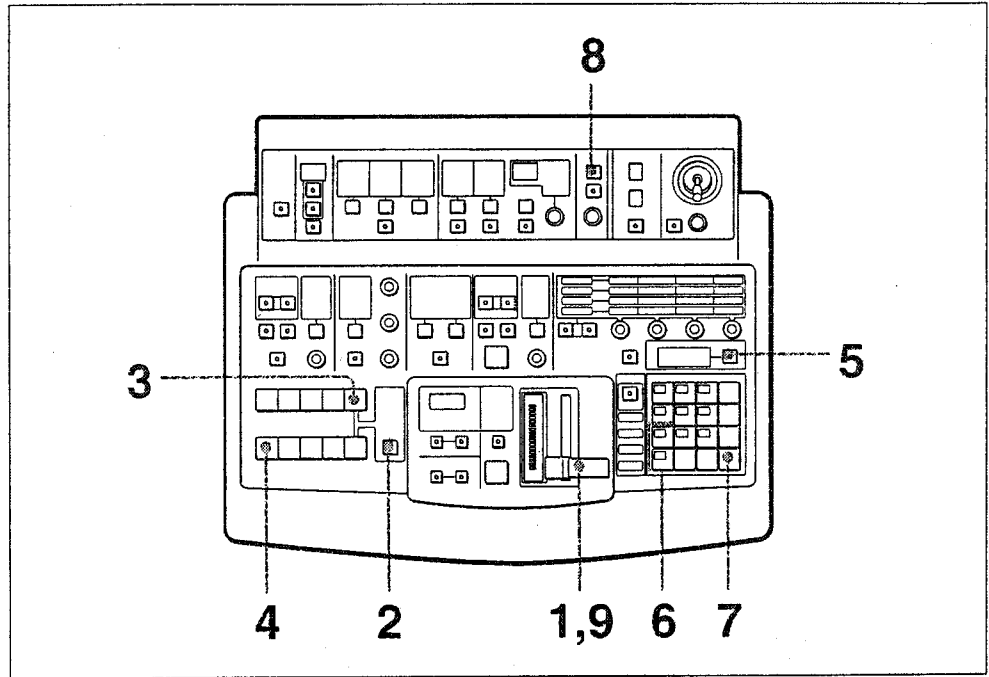

Basic operation (2) – Picture-in-picture

Preparation

- 1 Move the fader lever all the way forward.

Picture selection

- 2 Press the INT VIDEO SELECT button to turn on the COL BKGD indicator. A color background is selected from among the built-in video signals.

- 3 Press the INT VIDEO button of the BACKGROUND bus buttons. The pressed button lights in red, and a color background (color matte) is selected for the background picture. The color of the color matte can be adjusted. See "Adjusting the Color Matte" on page 5-37.

- 4 Press the FOREGROUND bus button **1**. The pressed button lights in amber, and the signal input to the VIDEO INPUTS 1 connector is selected for the foreground picture.

Effect selection

- 5 Press the SET button to turn on the indicator of the button. A pattern number can be entered using the PATTERN/KEY PAD buttons (pattern number designation mode).

Basic Operation

- 6** Press the numeric buttons **1**, **1**, **0** and **0**.
The PATTERN NUMBER display window shows [1.1.0.0.].

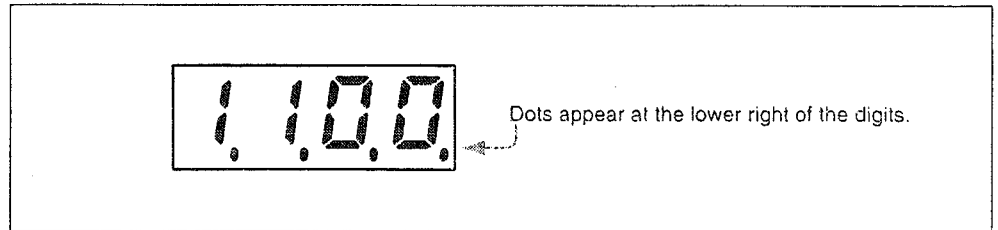

PATTERN NUMBER display window

- 7** Press the ENTER button.
The dots disappear, and a picture-in-picture (pattern number 1100) is selected.
The INT VIDEO button of the BACKGROUND bus buttons and the FOREGROUND bus button **1** light in red.

Addition of a border

- 8** Press the BORDER button.
The indicator of the button lights, and the border appears around the foreground picture.
The color and width of the border can be modified.
See "Modifying the Edge" on page 5-13.

Effect execution

- 9** Move the fader lever all the way back.
As the lever moves, the foreground picture with a border is gradually inserted in the background picture

Demonstration

The DFS-500/500P has a demo function which automatically executes 100 types of effects stored in ROM (read only memory) in the processor unit repeatedly. This demo function introduces the most effective editing possibilities. Use it to see what kinds of effects are available.

This demonstration is designed to execute effects using the signals input to the VIDEO INPUTS 1 and 2 connectors and the built-in video signal. Connect a VTR or a video camera to the VIDEO INPUTS 1 and 2 connectors, and press the HOLD INPUT button in the SNAP SHOT section to turn off the indicator of the button with the controller select switch in the processor unit set to BVE-900.

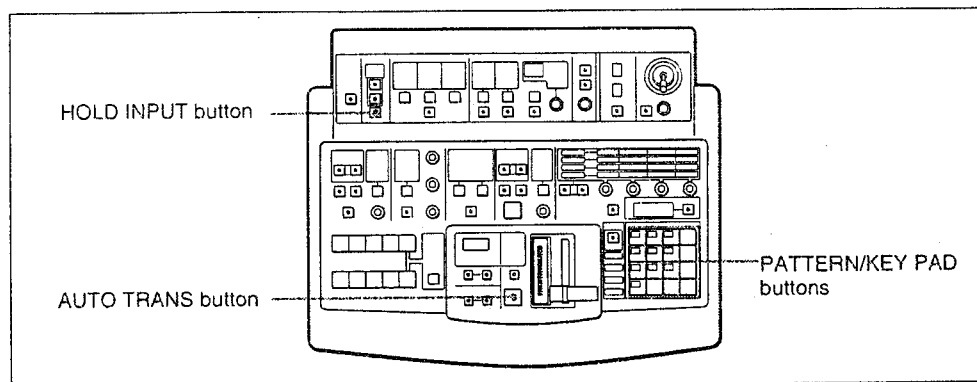

Demonstration

To start the demonstration

Press the AUTO TRANS button while holding down the PATTERN/KEY PAD buttons **1** and **9**.

One hundred effects stored in ROM are automatically executed repeatedly. While executing the demonstration, the PATTERN/KEY PAD buttons are lit up one after another clockwise.

While the demonstration is being executed, the buttons on the control panel other than the AUTO TRANS button are disabled.

To stop the demonstration

Press the AUTO TRANS button again.

The demonstration is finished, and the settings for the effect being executed when you stop the demonstration are recalled at the control panel.

Chapter 5

Operation

This chapter describes operating procedures from the beginning to the executing of effects, and introduces 13 representative effect patterns of the built-in effects. How to superimpose characters on a picture and how to modify effect patterns are also explained here.

The procedures in this section are explained supposing that the controller select switch in the processor unit is set to BVE-900. If the switch is set to the position other than BVE-900, the DFS-500/500P may operate in different way from the explanation.

Selecting Pictures	5-2
Selecting an Effect	5-4
Effects of the DFS-500/500P	5-4
Direct Pattern Select Mode	5-10
Pattern Number Designation Mode	5-11
Modifying the Edge – Border and Soft Edge	5-13
Moving the Location of the Pattern	
– Location (X), (Y), (Z)	5-14
Modifying a Pattern – User-Modify Effects	5-16
Superimposing Characters (1) – Title Key	5-17
Adding Compound Effects	5-20
Lighting	5-21
Trail	5-22
Drop Border	5-23
Shadow	5-24
Superimposing Characters (2) – Downstream Key	5-25
Setting the Transition	5-30
Setting the Duration of the Transition	5-30
Selecting the Direction of the Transition	5-32
Executing the Effect	5-34
Adjusting the Color Matte	5-37
Adjusting the Color	5-37
Copying the Color-Matte Data	5-38

Selecting Pictures

Selecting a foreground picture and a background picture

For the transition-type effect whereby one picture is replaced with another, select the picture before the effect (From picture, which will disappear) and that after the effect (To picture, which will appear). Normally the From picture is called a background picture and the To picture is a foreground picture. After executing a transition-type effect, the program picture changes from the background picture to the foreground picture.

For the animation-type effects with whereby an effect pattern is inserted in a picture or moves on a picture, select a picture which will fill the effect pattern and a picture to be cut with the effect pattern. Normally the former picture is called a foreground picture and the latter a background picture. After executing an animation-type effect, the picture does not replace the other one.

Selecting pictures

Select a video signal to be input to the VIDEO INPUTS 1 through 4 connectors on the rear panel which corresponds with buttons 1 through 4 or a built-in video signal which corresponds with the INT VIDEO button as the background or foreground picture.

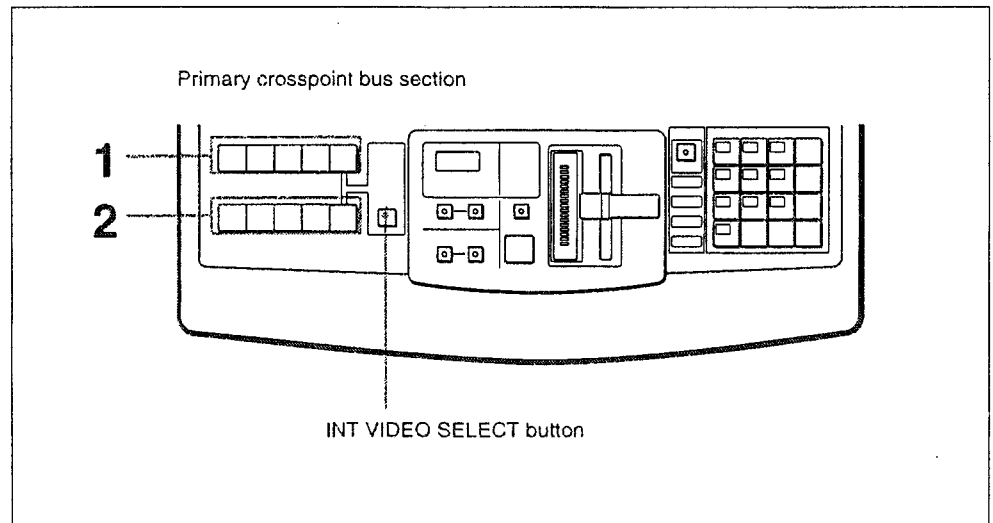

Selecting pictures

- 1** Press one of the BACKGROUND bus buttons to select a background picture. The pressed button lights.
- 2** Press one of the FOREGROUND bus buttons to select a background picture. The pressed button lights.

Monitoring a selected picture

You can monitor the selected picture on a program monitor connected to the PGM OUT connector. The button corresponding to the signal output from the PGM OUT connector is lit in red, and that for a signal not output is lit in amber.

Monitoring a program picture

Move the fader lever all the way back after selecting the background and foreground pictures and selecting an effect. The program picture composed of two pictures appears on the program monitor screen.

Selecting a built-in video signal

On some transition-type effects, the built-in video signal appears midway through the transition. The built-in video signal can also be used as a background or foreground picture.

Operation

Press the INT VIDEO SELECT button to select a built-in video signal from among the following signals. The corresponding indicator lights.

- **COL BKGD:** Color background signal
- **COL BAR:** Color-bar signal
- **GRID:** Grid-pattern signal

When you select a color background signal, a color-matte signal generated by the built-in color-matte generator is generally selected. The color can be adjusted as desired.

For details on color adjustment, see "Adjusting the Color Matte" on page 5-37.

Selecting a pattern signal

As a built-in video signal, 15 pattern signals such as an embossed pattern, can be selected besides the color-matte signal.

Operation

- 1 Press the SELECT button until the COL BKGD indicator lights.
- 2 Press the UP or DOWN button in the PATTERN/KEY PAD buttons, while holding down the INT VIDEO button of the BACKGROUND or FOREGROUND bus buttons.

Selecting an Effect

You can select the effects of the DFS-500/500P with the following two methods.

- Direct pattern select mode
- Pattern number designation mode

Effects of the DFS-500/500P

Kinds of Effects

The DFS-500/500P DME switcher has 365 effect patterns, to each of which a specific pattern number is assigned. Pattern number 1000 and after mean DME (Digital Multi Effects). The effect patterns are classified to several groups according to their pattern, such as wipe, picture-in-picture.

Effects having adjustable parameters

Some effect patterns allow one or more additional effects to be applied to a basic pattern such as a border or moving the pattern location. Parameters to be set depend on the effect pattern.

User-modify effects

Some effects allow the pattern to be modified. These effects are called user-modify effects. Parameters specific to the selected user-modify effects can be set with the parameter-setting controls in the EFFECT CONTROL section.

Transition-type or animation-type effects

Effects patterns are classified into the following two types according to the effect motion.

Transition type: When an effect is executed, a picture is replaced with another one (one-directional motion).

Animation type: After the effect, the picture before the effect is not replaced with another one. When the same effect is executed again, the effect is done in the reverse direction of the previous execution and the picture displayed before the previous execution appears (back-and-forth motion).



As appendixes, the following tables and pattern-image list are attached.

- Types of effects (page A-7)
- Adjustable parameters (page A-8)
- Effects classified by type of motion (page A-10)
- Parameters for modifying effects patterns (page A-11)
- Effect pattern image list (page A-14)

This section introduces the patterns assigned to the PATTERN/KEY PAD buttons at the factory. You can select one of these patterns only by pressing the corresponding button (direct pattern mode).

7 button
Pattern number: 1
Pattern image



Effect type: Wipe
Motion type: Transition
Adjustable parameters: Border, soft edge



Pattern number 1 (wipe)

A foreground picture appears at the left, and the background picture is gradually replaced with the foreground picture from left to right.

8 button
Pattern number: 9
Pattern image



Effect type: Wipe
Motion type: Transition
Adjustable parameters: Border, soft edge



Pattern number 9 (wipe)

A foreground picture appears at the upper left corner, and the background picture is gradually replaced with the foreground picture from the upper left corner to the lower right corner.

Selecting an Effect

9 button

Pattern number: 24

Pattern image



Effect type: Wipe

Motion type: Transition

Adjustable parameters: Border, soft edge, X position, Y position

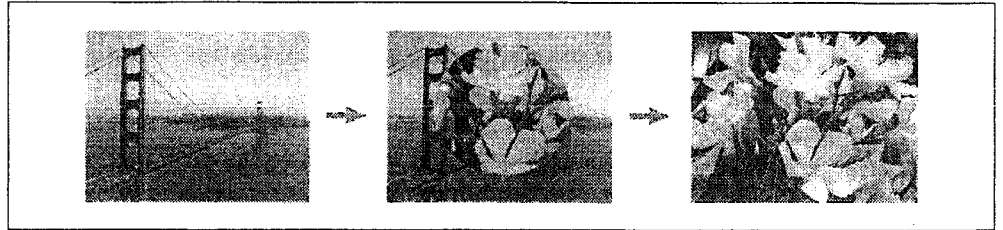

Pattern number 24 (wipe)

A foreground picture appears in a circle, then grows larger and larger until it replaces the background picture.

4 button

Pattern number: 700

Pattern image



Effect type: Matrix wipe

Motion type: Transition

Adjustable parameter: Border, trail, drop border, shadow



Pattern number 700 (matrix wipe)

A foreground picture appears at the upper left corner, and the foreground picture moves in to replace the background picture from the upper left corner to the lower right corner.

INS button

Pattern number: 1059

Effect type: Cut

Motion type: Transition

Adjustable parameter: None

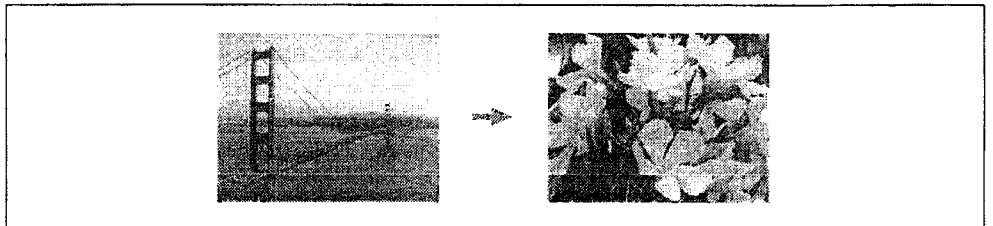

Pattern number 1059 (cut)

A background picture instantaneously changes to a foreground picture.

DEL button
Pattern number: 1080

Effect type: Mix
Motion type: Transition
Adjustable parameters: Trail, drop border, shadow (in title mode only)

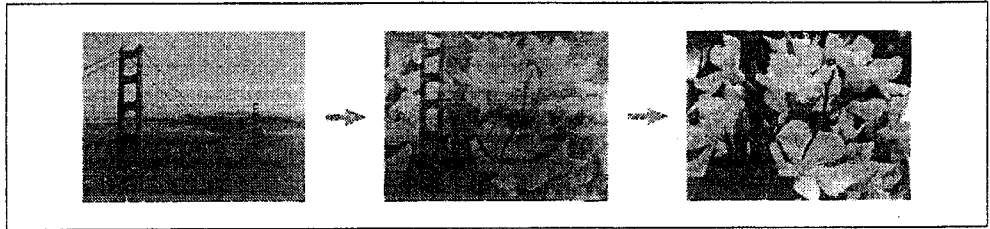

Pattern number 1080 (mix)

A background picture gradually fades out while a foreground picture gradually fades in by mixing with the background picture.

RST button
Pattern number: 1100

Effect type: Picture-in-picture
Motion type: Animation
Adjustable parameters: Border, X position, Y position, trail, drop border, shadow

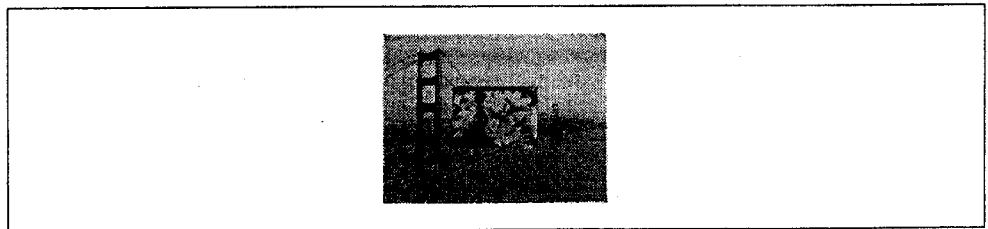

Effect number 1100 (picture-in-picture)

A foreground picture is inserted in a background picture.

5 button
Pattern number: 1300
Pattern image



Effect type: Slide
Motion type: Transition
Adjustable parameters: Border, trail, drop border, shadow



Pattern number 1300 (slide)

A foreground picture appears at the right and gradually slides in to replace the background picture which gradually slides off-screen to the left.

Selecting an Effect

6 button

Pattern number: 1700

Pattern image



Effect type: Three-dimensional turn

Motion type: Transition

Adjustable parameters: Border, lighting (three kinds), trail, drop border, shadow

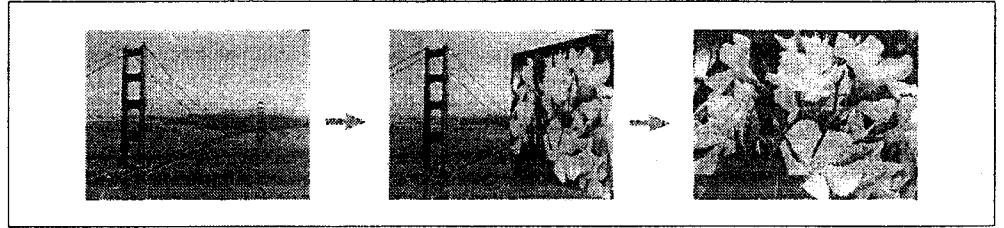

Pattern number 1700 (three-dimensional turn)

A foreground picture appears at the right as a pivot axis, and replaces the background picture gradually with the motion like turning a rigid page.

1 button

Pattern number: 1902

Pattern image



Effect type: Turn

Motion type: Transition

Adjustable parameters: Border, lighting (three kinds), trail, drop border, shadow

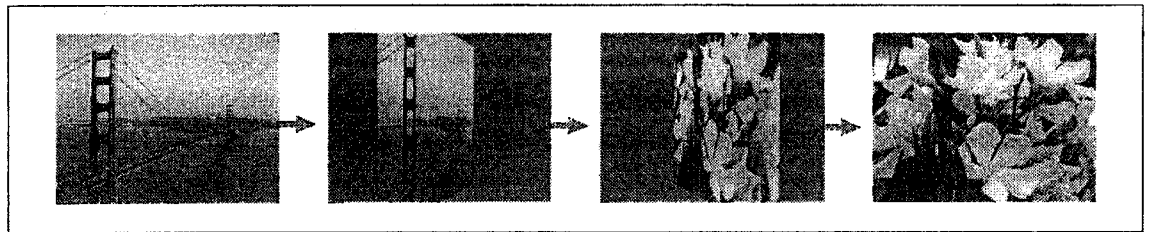

Pattern number 1902 (turn)

A background picture turns around the vertical axis and disappears, and a foreground picture appears instead. (On the background of the replacing pictures, a built-in video signal appears.)

2 button

Pattern number: 2000

Pattern image



Effect type: Twist

Motion type: Transition

Adjustable parameters: Border, lighting (two kinds), trail, drop border, shadow

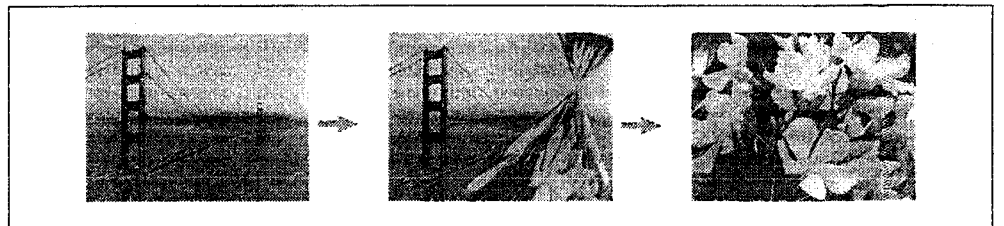

Pattern number 2000 (twist)

A foreground picture appears on a background picture by twisting and replacing it.

3 button

Pattern number: 2100

Pattern image



Effect type: Page turn

Motion type: Transition

Adjustable parameters: Border, lighting (one kind), trail, drop border, shadow

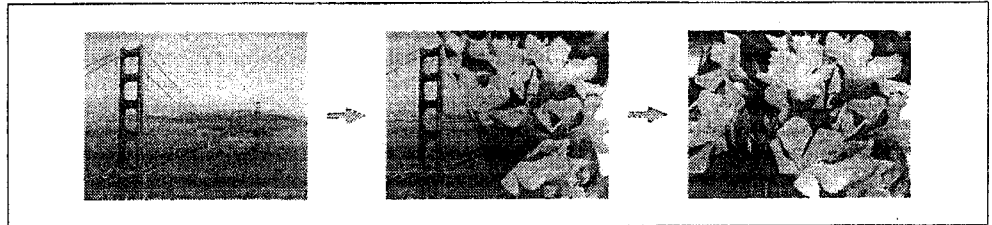

Pattern number 2100 (page turn)

A background picture is replaced with a foreground picture with the motion like turning a page.

0 button

Pattern number: 2200

Pattern image



Effect type: Sphere

Motion type: Transition

Adjustable parameters: Border, lighting (one kind), trail, drop border, shadow



Pattern number 2200 (sphere)

A spherical-form foreground picture appears on a background picture and replaces it.

Selecting an Effect

Direct Pattern Select Mode

You can select a desired effect pattern assigned on the buttons (13 patterns) by pressing the PATTERN/KEY PAD buttons (0 through 9, RST, DEL, INS).

Operation

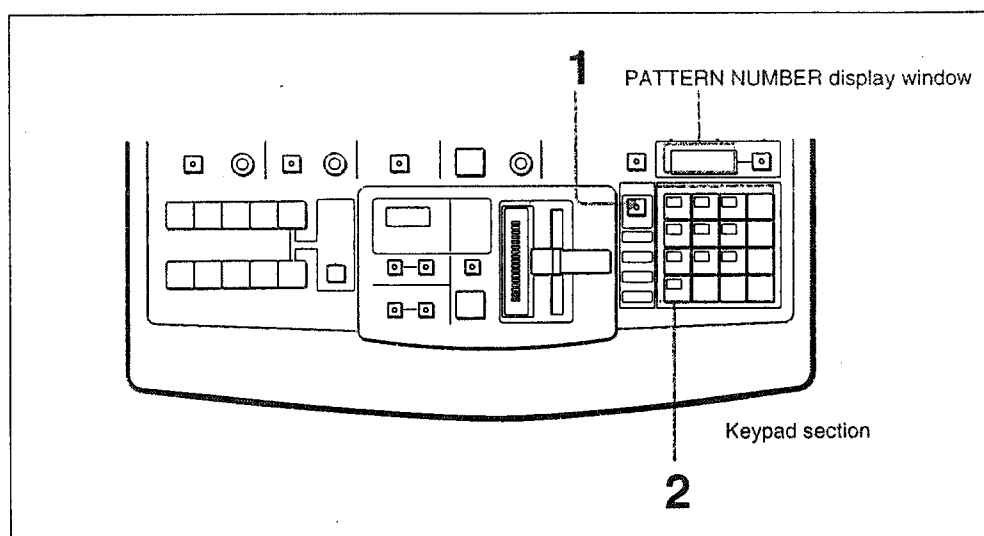

Direct pattern selection

- 1** Press the DIRECT PATTERN button to turn on the indicator of the button. Direct pattern select mode is selected.

Note

When the indicator of the EDIT button in the USER PROGRAM section (see page 2-17) is lit, direct pattern select mode cannot be selected. Press the EDIT button to turn off the indicator.

- 2** Press the button to which the desired effect pattern is assigned. The pressed button lights, and the PATTERN NUMBER display window shows the selected pattern number.

Assignment to the numeric buttons 0 through 9 can be changed as desired, but not for the RST, DEL and INS buttons.

For changing the assignment, see "Changing the Direct Pattern Assignment" on page 6-2.

Pattern Number Designation Mode

You can select a desired effect pattern by designating the pattern number with the numeric buttons.

Operation

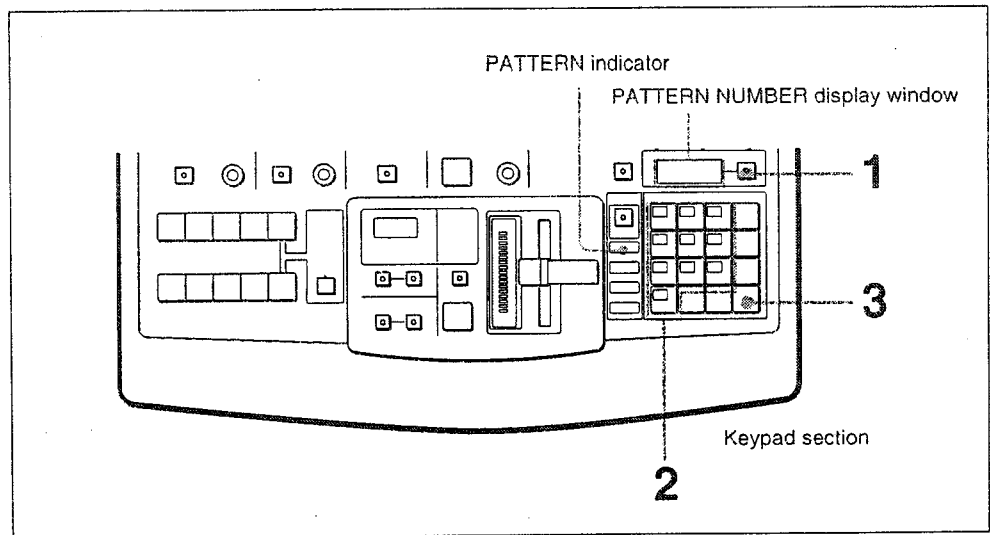

Designating the pattern number

- 1** Press the SET button to turn on the indicator of the button .
The PATTERN indicator also lights, and pattern number designation mode is selected.
- 2** Enter the pattern number using the numeric buttons of the PATTERN/KEY PAD buttons.
The PATTERN NUMBER display window shows the entered number. Dots appear at the lower right of the entered digits to indicate that the entered number is not yet finalized.
- 3** Press the ENTER button.
The dots disappear and the pattern selection is completed.

When the wrong pattern number is entered

Press the RST button to reset the display to 0, and enter the correct number.

Notes

- If the pattern corresponding to the entered number does not exist, the next highest effective number is automatically set. If a number above 9310 is entered, 1 is automatically selected.
- If you designate a pattern number 3000 through 8999 and press the ENTER button, a warning sound is heard.

Selecting an Effect

Selecting a pattern number using the UP or DOWN button

In both direct pattern select mode and pattern number designation mode, you can change the pattern number displayed in the PATTERN NUMBER display window by pressing the UP or DOWN button of the PATTERN/KEY PAD buttons. When dots appear at the lower right of the digits, press the ENTER button after entering the pattern number.



Modifying the Edge – Border and Soft Edge

Some effects allow the edge to be modified by adding a colored border or making the line blurry (giving its soft edge).

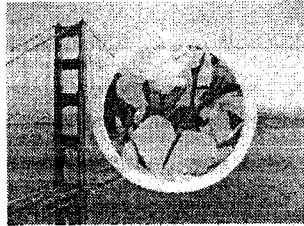

Border

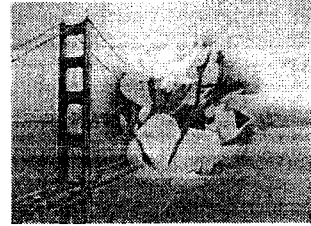

Soft edge

Operation

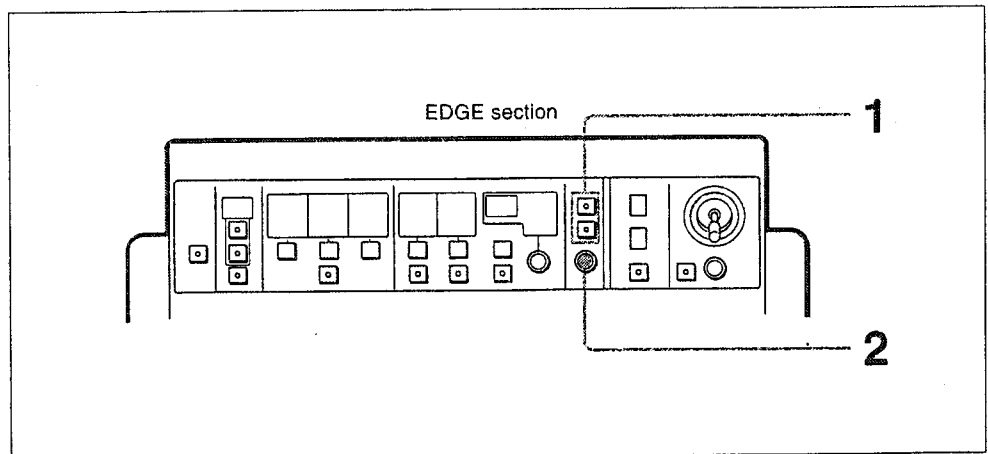

Modifying the edge

- 1 Press the BORDER button for a border, or the SOFT button for a soft edge. The indicator of the pressed button lights.

The color of the border can be changed by adjusting the border-matte signal generated by the built-in color generator.

For adjustment, see "Adjusting the Color Matte" on page 5-37.

- 2 Turn the WIDTH/SOFT control to adjust the width of the border or its softness.

Note

With some effects, a border or soft edge effect cannot be added. When you press the BORDER or SOFT button with such an effect selected, a warning sound is heard.

For the effects to which you cannot add a border or soft edge effect, see "Adjustable Parameters" on page A-8.

Moving the Location of the Pattern – Location (X), (Y), (Z)

Some effects allow the position or size of the effect pattern (a foreground picture, the area which the effect is applied) to be adjusted.

Operation

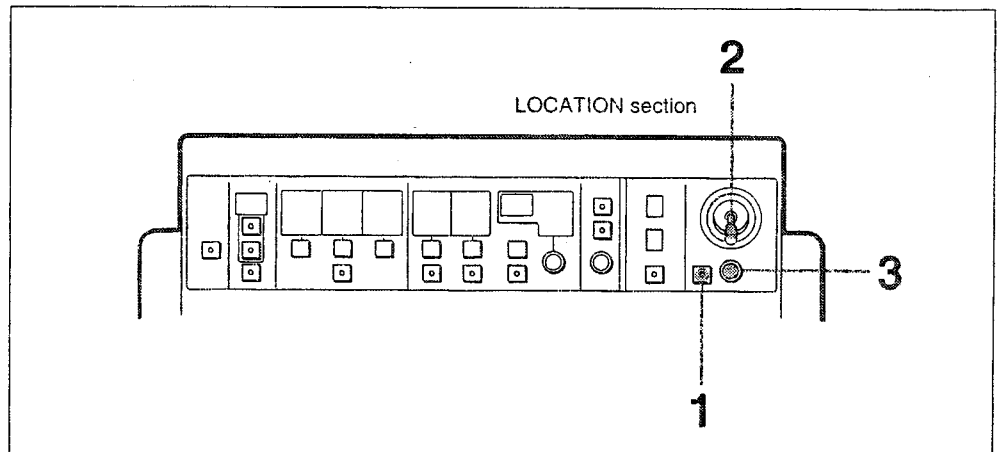

Moving the location of the pattern

- 1** Press the LOCATION button to turn on the indicator of the button.
- 2** Move the (X)/(Y) joystick to locate the pattern horizontally (X-axis direction) or vertically (Y-axis direction) to the desired position.

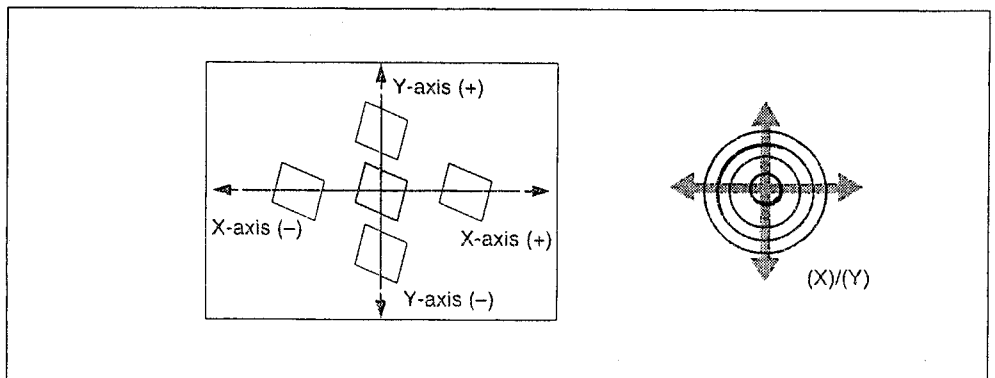

Moving the pattern horizontally and vertically

- 3 Turn the (Z) control to set the size of the effect pattern (depth of the screen, Z-axis direction).

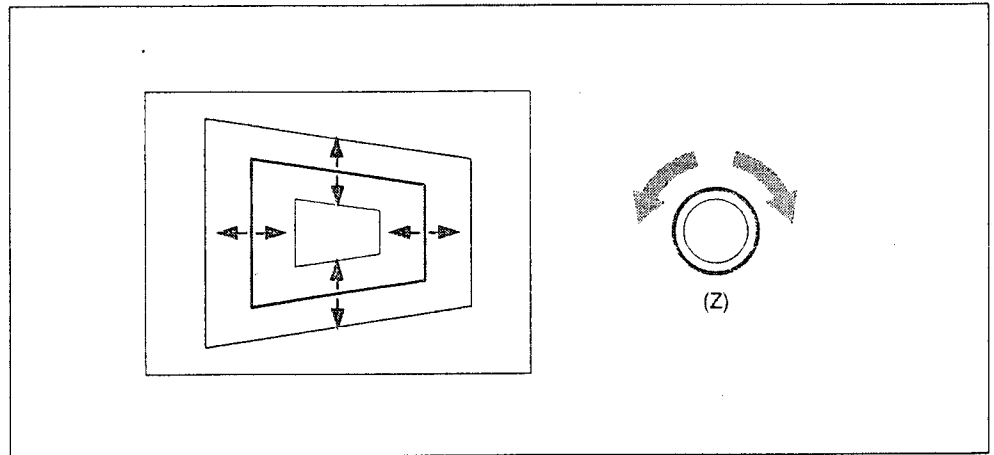

Setting the size of the pattern

To initialize the location and size of the pattern

Press the LOCATION button to turn off the indicator of the button.

Note

When you select an effect pattern whose location and size cannot be modified and press the LOCATION button or move the (X)/(Y) joystick or (Z) control, a warning sound is heard.

For the effects whose location and size cannot be modified, see "Adjustable Parameters" on page A-8.

Modifying a Pattern – User-Modify Effects

When you select an effect whose parameters can be changed (user-modify effect), the MODIFY indicator in the EFFECT CONTROL section lights to indicate that the parameters can be set.

For setting parameters, use the parameter-setting controls F1 through F4 in the EFFECT CONTROL section.

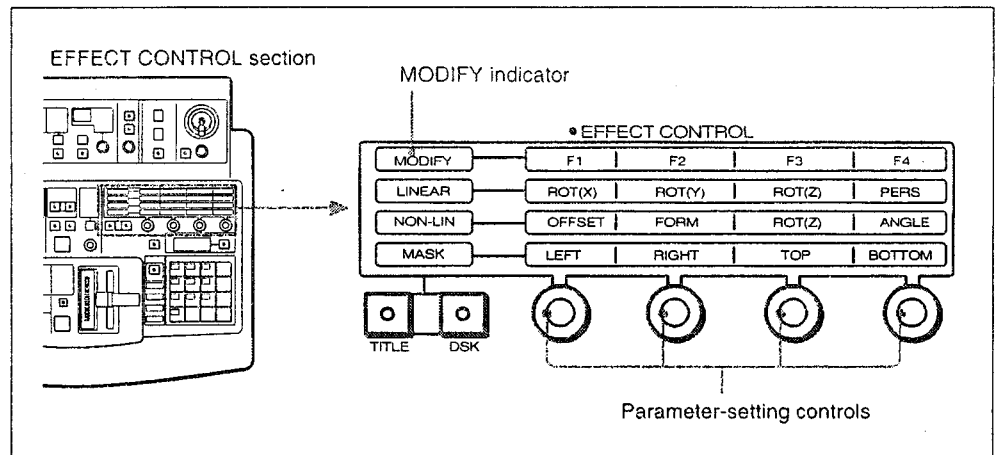

Parameter-setting controls

Check the number of the user-modify effects by referring to "Parameters for Modifying Effect Patterns" on page A-11. The parameters to be set depend on the effect. For details, see "Parameters for Modifying Effect Patterns." When you move the disabled control, a warning sound is heard.

Example Pattern number: 1016
Effect type: Variable mosaic

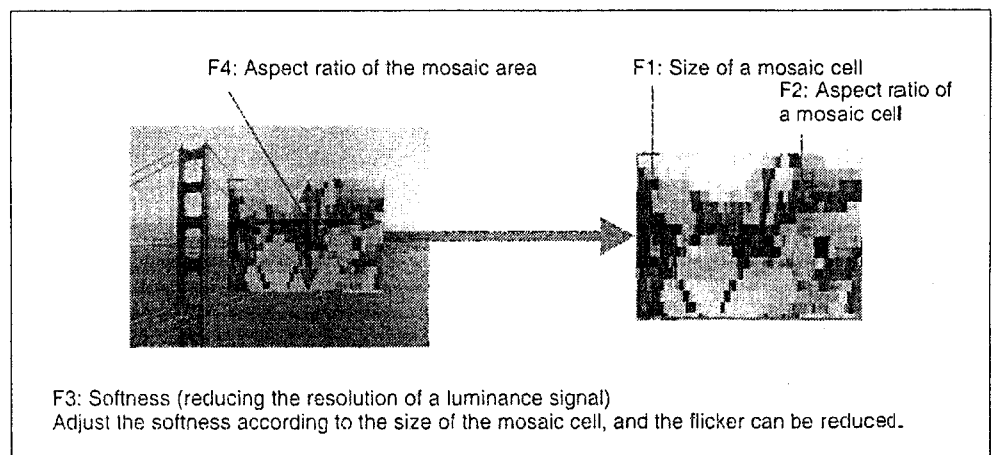

Setting parameters of pattern 1016

This effect allows the location and size of the mosaic area to be adjusted using the (X)/(Y) joystick or (Z) control in the LOCATION section besides allowing to set the parameters shown in figure above.

For details on how to adjust the location and size, see "Moving the Location of the Pattern – Location (X), (Y), (Z)" on page 5-14.

Superimposing Characters (1) – Title Key

You can superimpose characters or figures with an effect applied on the background picture.

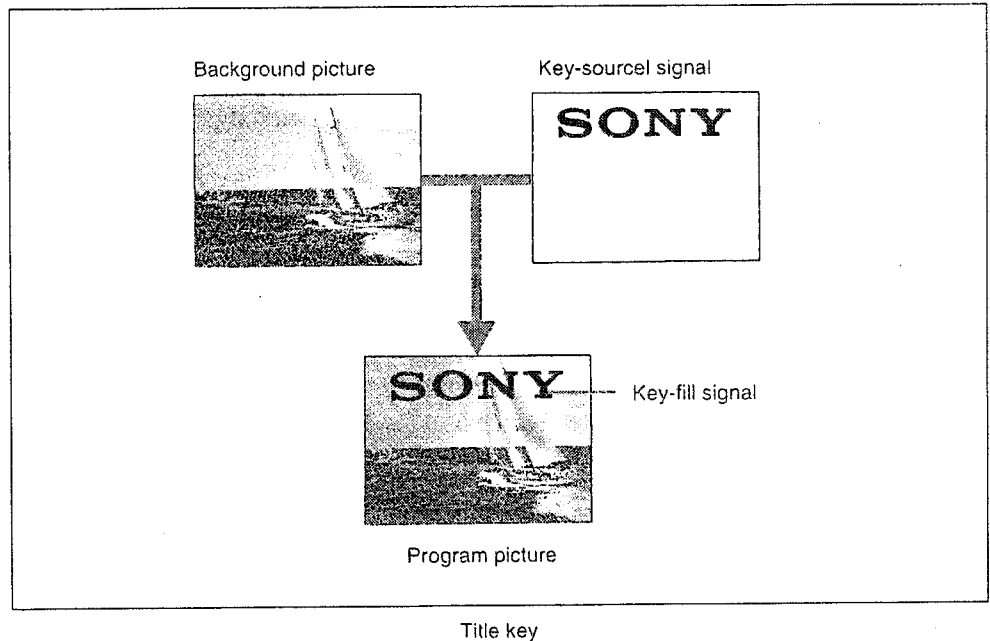

Operation

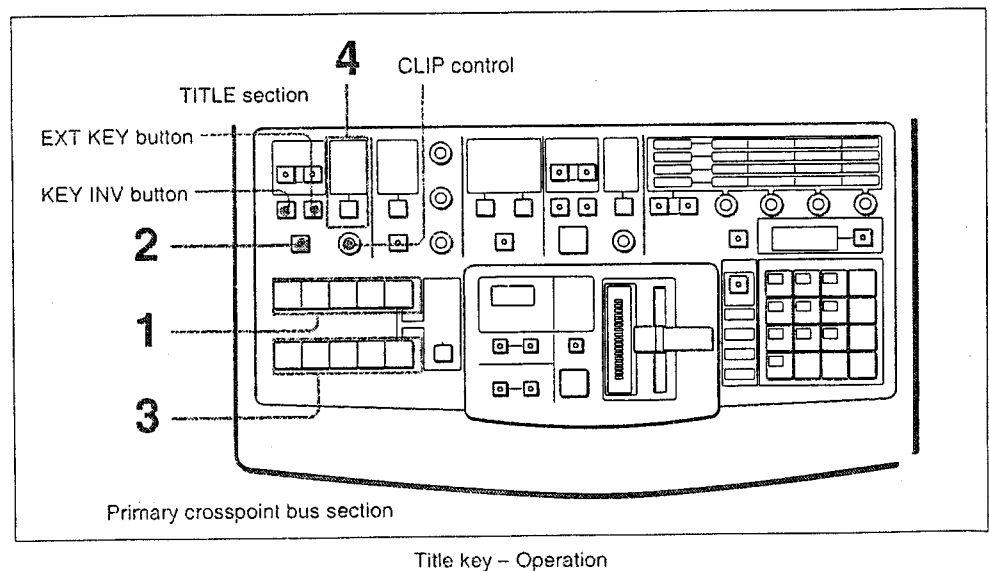

- 1** Press one of the BACKGROUND bus buttons to select a picture in which characters or figures are to be inserted.
- 2** Press the TITLE button to turn on the indicator of the button. Title mode is selected and the NORM/REV indicator in the EFFECT TRANSITION section lights. The motion type of effects will be animation type, and back-and-forth motion will be obtained.

(to be continued)

Superimposing characters (1) – Title Key

- 3** Select a key-source signal which includes characters or figures to be inserted.
To use the signal input to the VIDEO INPUTS connectors (self-key mode), press the FOREGROUND bus button corresponding to the connector. The pressed button lights.
To use an external key-source signal input to the EXT KEY IN connector (external key mode), press the EXT KEY button to turn on the indicator of the button.
- 4** Press the FILL button to select the key-fill signal, which fills the inside of the inserted characters or figures.
FRGD BUS: A picture selected with the FOREGROUND bus button (in self-key mode, a key-source signal is included). In external key mode, a built-in video signal cannot be used.
BORD MAT: Border matte
SHAD MAT: Shadow matte
When you select a border matte or shadow matte, you can adjust the color with the buttons in the MATTES/BKGD section.

When you start the execution of the effect, the title-key signal with that effect is inserted in the background picture.

To release title mode

Press the TITLE button to turn off the indicator of the button.

To adjust the outline of the inserted characters or figures

When the outline of the inserted characters or figures is not sharp, turn the CLIP control to adjust the key clipping level.

In external key mode, turn the TITLE EXT KEY CLIP VR on the AD-76 board in the processor unit.

To invert the key-source signal polarity

Press the KEY INV button according to the signal polarity (black and white) of the key-source signal.

White characters on a black background: The indicator of the KEY INV button does not light.

Black characters on a white background: The indicator of the KEY INV button lights.

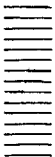

Masking a part of characters or figures

You can mask unnecessary part of the inserted characters or figures.

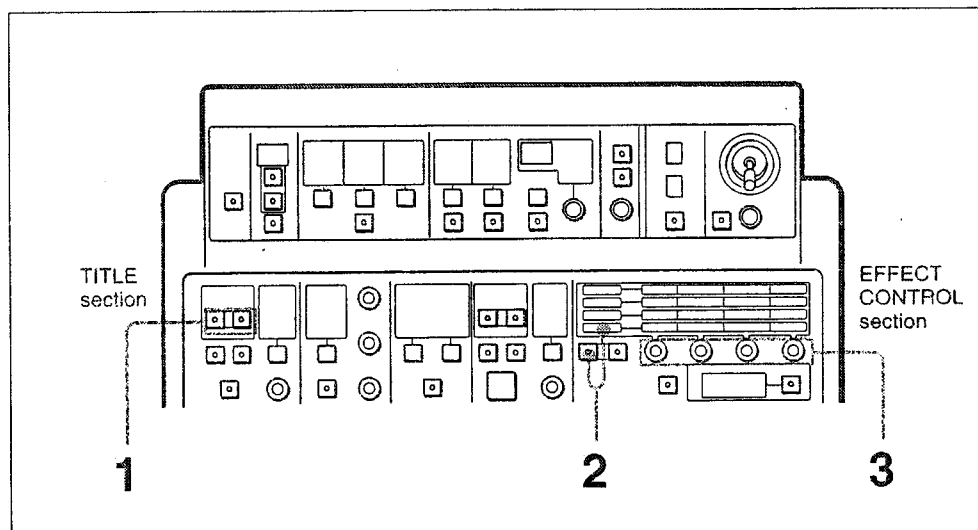

Title key – Masking

- 1** Press the MASK button to turn on the indicator of the button.
NORMAL: To mask the outside of the specified rectangular area
INVERT: To mask the inside of the specified rectangular area
- 2** Check that the indicator of the TITLE button and the MASK indicator in the EFFECT CONTROL section is lit.
If the indicator is not lit, press the TITLE button to turn on the indicators.
- 3** Turn the parameter-setting controls to adjust the rectangular area.
The controls let you specify the left, right, top and bottom of the area respectively.

To stop masking

Press the MASK button again to turn off the indicator of the button.

Adding Compound Effects

The following effects are added to the foreground picture on some effect patterns.

- **Lighting:** Lighting effects are added to.
- **Trail:** An effect pattern moves with a trail.
- **Drop border:** A drop border is added behind the effect pattern which looks like having an extended shadow.
- **Shadow:** A shadow is added around the effect pattern.

Example

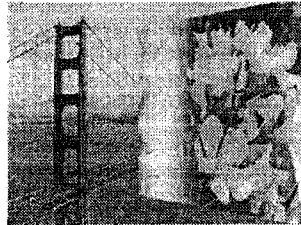

Lighting

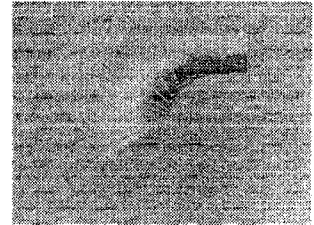

Trail

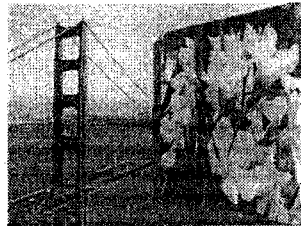

Drop border



Shadow

Notes

- Compound effects are available only when the BKDF-501/501P trail and lighting board (optional) is inserted in the processor unit.
- Compound effects cannot be added on some effect patterns.
See "Adjustable Parameters" on page A-8.
- A trail, drop border and shadow cannot be applied simultaneously, but lighting effects can be applied in combination with these effect.



Lighting

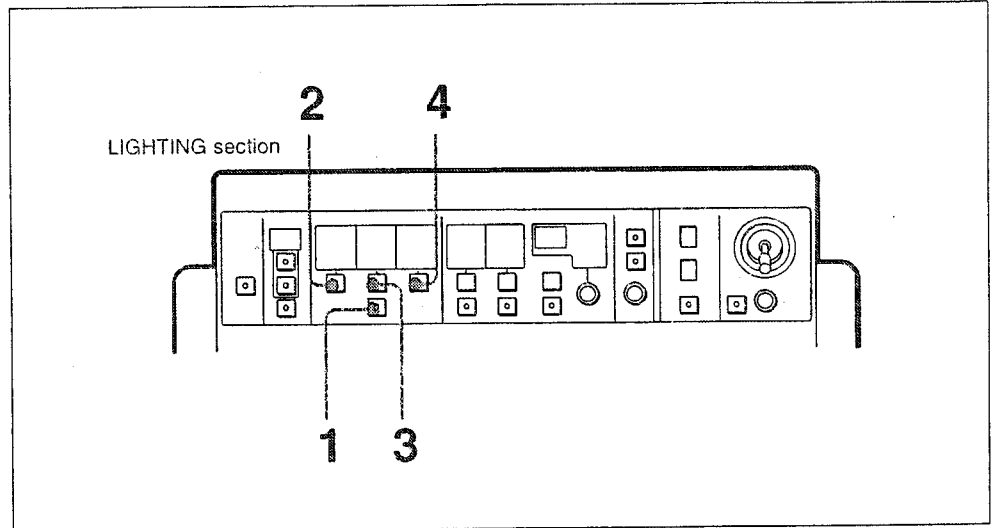

Lighting

- 1** Press the **LIGHTING** button to turn on the indicator of the button. Lighting mode is selected. When you select an effect pattern to which a lighting effect cannot be added, pressing the **LIGHTING** button makes a warning sound.

Note

Lighting effect cannot be applied to linear-type user-program effects, but can be applied to non-linear-type user-program effects.

- 2** Press the **TYPE** button to select the type of the lighting.
SPOT: Spot lighting
LINE: Line lighting
PLANE: Plane lighting
- 3** Press the **WIDTH** button to select the width of the lighting
WIDE: Wide lighting
MEDIUM: Medium-width lighting
NARROW: Narrow lighting
- 4** Press the **INTENSITY** button to select the luminance of lighting.
HIGH: High luminance
MEDIUM: Medium luminance
LOW: Low luminance

Then execute the effect, and the lighting effect set in the above procedures is applied to the foreground picture during execution.

To remove lighting

Press the **LIGHTING** button to turn off the indicator of the button.

Adding Compound Effects

Trail

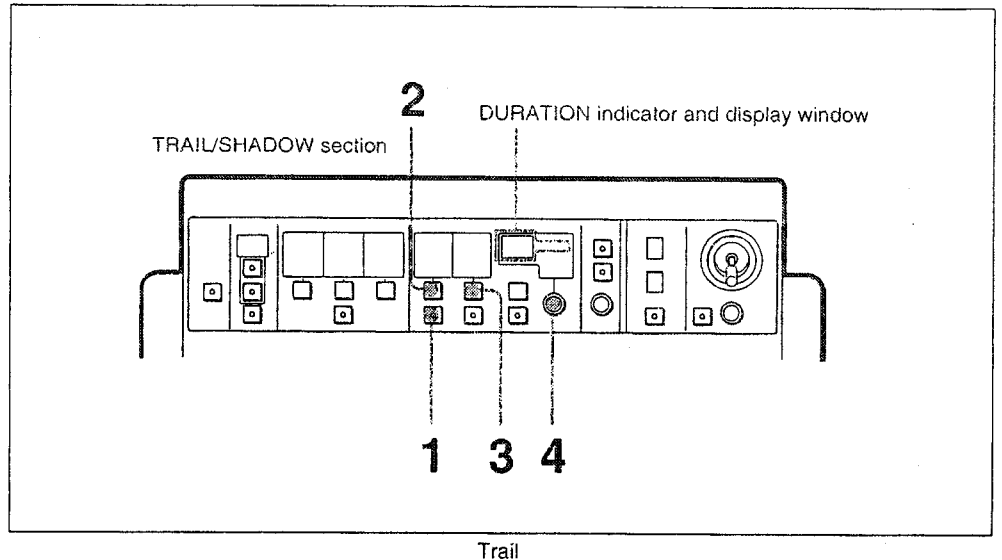

- 1** Press the TRAIL button to turn on the indicator of the button. The DURATION indicator of the FUNCTION indicators also lights, and trail mode is selected. When you select the effect to which a trail cannot be added, pressing the TRAIL button makes a warning sound, and trail mode cannot be selected.
- 2** Press the TYPE button to select the type of trail.
HARD: The trail disappears quickly.
SOFT: The trail disappears slowly.
HARD STAR: The trail disappears quickly with a stardust effect.
SOFT STAR: The trail disappears slowly with a stardust effect.
- 3** Press the FILL button to select a signal to fill the trail.
SELF: A foreground picture
BORD MAT: A border matte
SHAD MAT: A shadow matte
RNDM MAT: A random matte which changes colors at random
When you select a border matte or shadow matte, you can adjust color with the MATTES/BKGD section.
- 4** Turn the CONTROL knob to set the duration of the trail in units of frames. The set duration appears in the DURATION display window. The duration of the trail is different from the duration of the transition for the effect set with the EFFECT TRANSITION section. It is the period until the trail disappears.

Then execute the effect, and the trail is added to the effect pattern for the period set as the duration of the trail in step 4.

To make the trail disappear

Press the TRAIL button to turn off the indicator of the button.

Drop Border

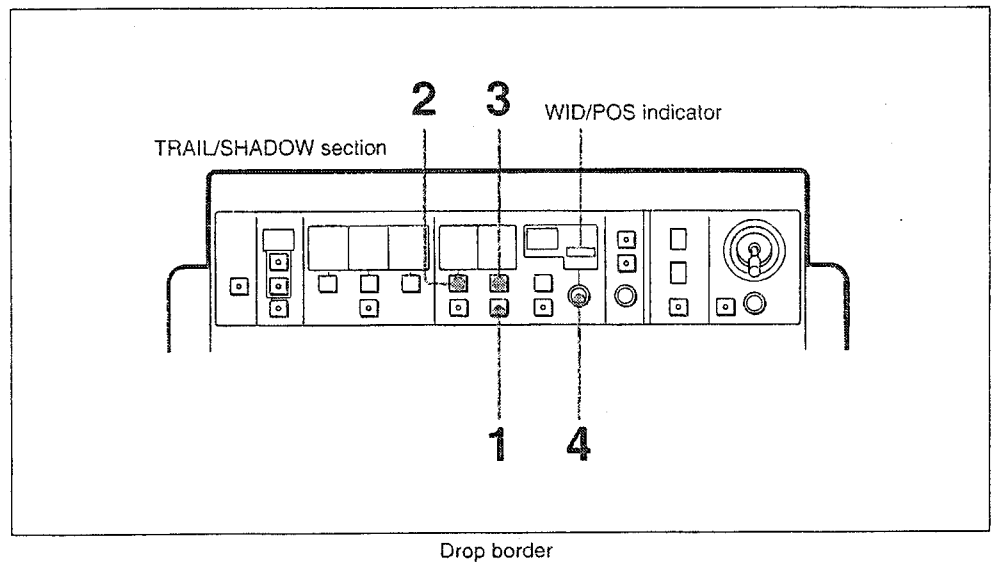

- 1** Press the **DROP BORDER** button to turn on the indicator of the button. The **WID/POS** indicator of the **FUNCTION** indicators also lights, and drop border mode is selected.
When you select an effect pattern to which a border cannot be added, pressing the **DROP BORDER** button makes a warning sound, and drop border mode cannot be selected.
- 2** Press the **TYPE** button to select the type of border.
HARD: The border with a hard edge
SOFT: The border with a soft edge
HARD STAR: The border with a hard edge having a stardust effect
SOFT STAR: The border with a soft edge having a stardust effect
- 3** Press the **FILL** button to select the signal to fill the drop border.
SELF: The foreground picture
BORD MAT: A border matte
SHAD MAT: A shadow matte
RNDM MAT: A random matte which changes colors at random
When you select a border matte or shadow matte, you can adjust color with the **MATTES/BKGD** section.
- 4** Turn the **CONTROL** knob to adjust the width and position of the drop border. Turning the knob counterclockwise places the border at lower left, and turning it clockwise places it at lower right.

Then execute the effect, and the drop border set with the above procedures is added to the effect pattern.

To make the drop border disappear

Press the **DROP BORDER** button to turn off the indicator of the button.

Adding Compound Effects

Shadow

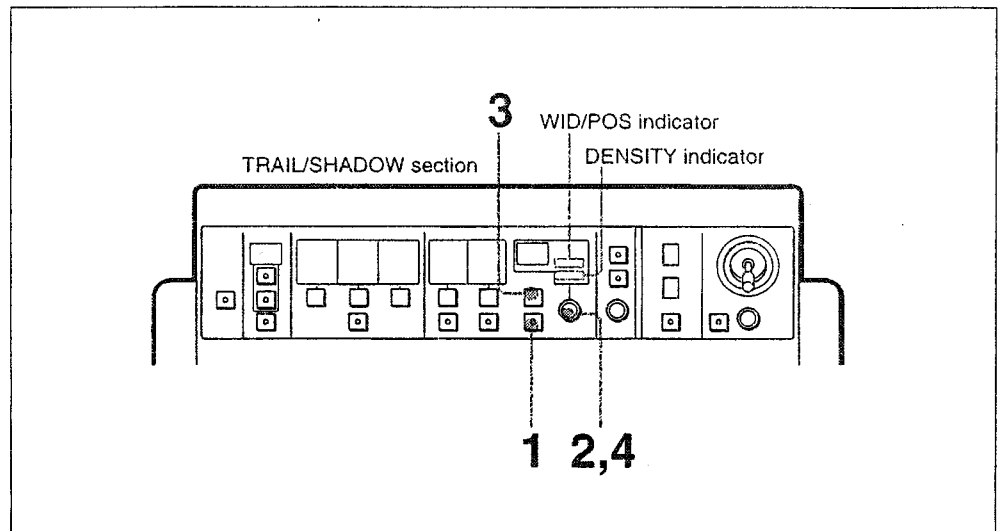

Shadow

- 1** Press the SHADOW button to turn on the indicator of the button. The WID/POS indicator of the FUNCTION indicators also lights, and shadow mode is selected. If the WID/POS indicator does not light, press the DENSITY/POSITION button. When you select an effect pattern to which a shadow cannot be added, a warning sound is heard and shadow mode cannot be selected.
- 2** Turn the CONTROL knob to adjust the position of the shadow. Turning the knob counterclockwise places the shadow at lower left, and turning it clockwise places it at lower right.
- 3** Press the DENSITY/POSITION button. The DENSITY indicator of the FUNCTION indicators lights.
- 4** Turn the CONTROL knob to adjust the density of shadow.

Then execute the effect, and the shadow set with the above procedures is added to the effect pattern.

To adjust the color of the shadow

Adjust the color of the shadow with the MATTES/BKGD section.

To make the shadow disappear

Press the SHADOW button to turn off the indicator of the button.

Superimposing Characters (2)

– Downstream Key

You can superimpose characters or figures on a program picture which is made up of a background picture and a foreground picture using the built-in downstream-keyer circuit.

Unlike a title key, a downstream key is superimposed on a program picture when an effect is executed.

See "Key Signal Connections" on page 3-6 to input required key-source signals and key-fill signals.

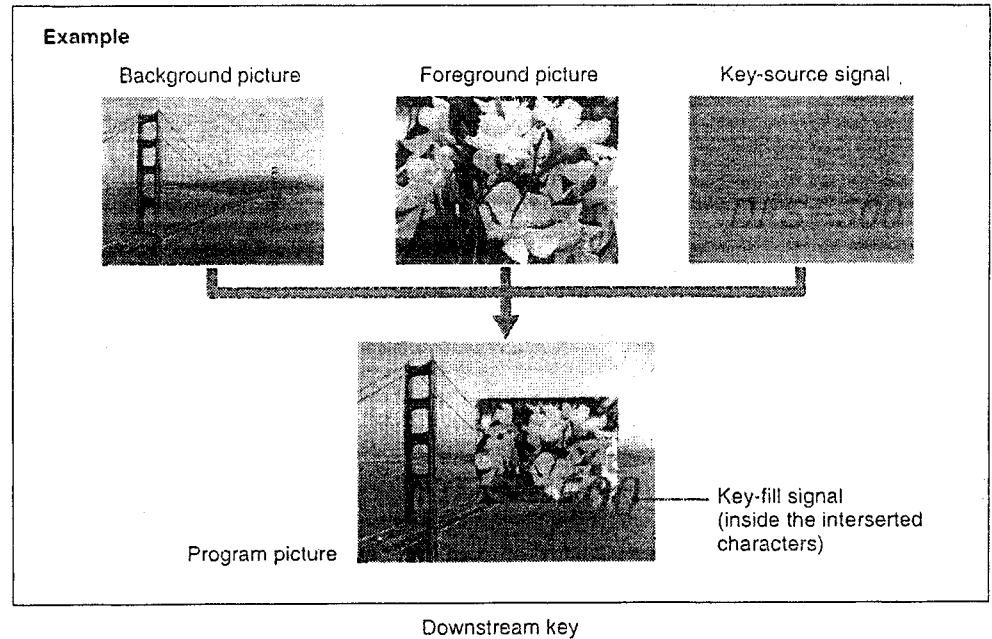

Note

The downstream keyer is disabled when a BKDF-502/502P DSK board (optional) is not mounted on the internal board or when the controller select switch on the SY-172 board is set to BVS-3000.

Superimposing Characters (2) – Downstream Key

Basic Operation

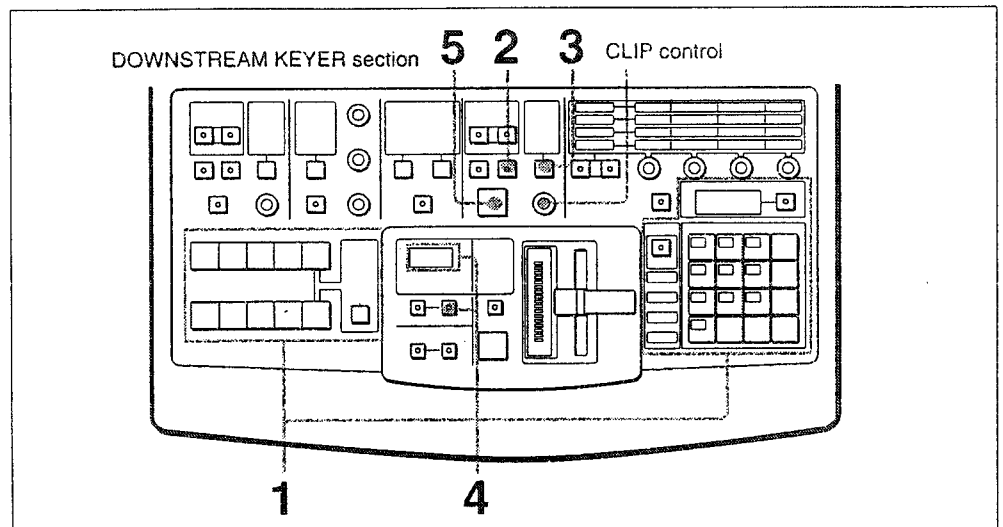

Downstream keyer – Basic operation

- 1** Prepare a picture in which characters or figures are superimposed. Select a background picture, a foreground picture and an effect pattern. See pages 5-2, 5-3, and 5-4.
- 2** Select a key-source signal which includes characters or figures to be superimposed.
To use a signal input to the DSK KEY IN connector as a key-source signal (external key mode), press the EXT KEY button, and the indicator of the button lights.
When the EXT KEY button is not lit (self-key mode), the luminance signal of the signal input to the DSK VIDEO IN connector is used as the key-source signal
- 3** Press the FILL button to select the signal to fill the superimposed characters or figures.
 The corresponding indicator lights.
DSK VIDEO: The signal input to the DSK VIDEO IN connector
DSK MAT: The built-in DSK matte
NONE: No fill signal

Note
 When NONE is selected, the DSK border is automatically turned on. If the DSK border is turned off, a key signal for a downstream key is not superimposed.
- 4** Set the duration of the transition for the downstream key.
For details on the procedures for making the settings, see "Setting the Duration of the Transition" on page 5-30.

5 Press the DSK MIX button.

The characters or figures appear in the program picture with the set duration (fade-in). When the duration of the transition is set to 0, the characters or figures appear instantaneously (cut-in). While the characters or figures are being inserted, the DSK MIX button is lit in amber, then changes to red when they are completely inserted.

Pressing the DSK MIX button again makes the characters or figures fade out or cut out.

To cancel the fade-in or fade-out of the downstream key

After step 5, press the DSK MIX button while holding down the SHIFT button in the keypad section. Then the picture before superimposing the characters or figures is retrieved.

To superimpose the characters or figures instantaneously (cut-in)

In step 5, press the DSK MIX button while holding down the SHIFT button. Then the characters or figures instantaneously appear even if the duration of the transition is set to the value other than 0.

When the characters or figures appear, pressing the DSK MIX button while holding down the SHIFT button makes them disappear instantaneously.

To adjust the outline of the characters or figures

When the outline of the inserted characters or figures is not clear, turn the CLIP control to adjust the key clipping level.

In external key mode, adjust the key clipping level with the DSK EXT KEY CLIP VR on the DA-63 board in the processor unit.

To invert the key-source signal polarity

Press the KEY INV button according to the polarity of the key-source signal (black or white) as follows:

White characters on a black background: The indicator of the button does not light.

Black characters on a white background: The indicator of the button lights.

Superimposing Characters (2) – Downstream Key

Adding a border to the inserted characters or figures

You can add a border to the inserted characters or figures. The color of the border can be adjusted with the DSK border matte.

For details on adjusting the color, see "Adjusting the Color Matte" on page 5-37.

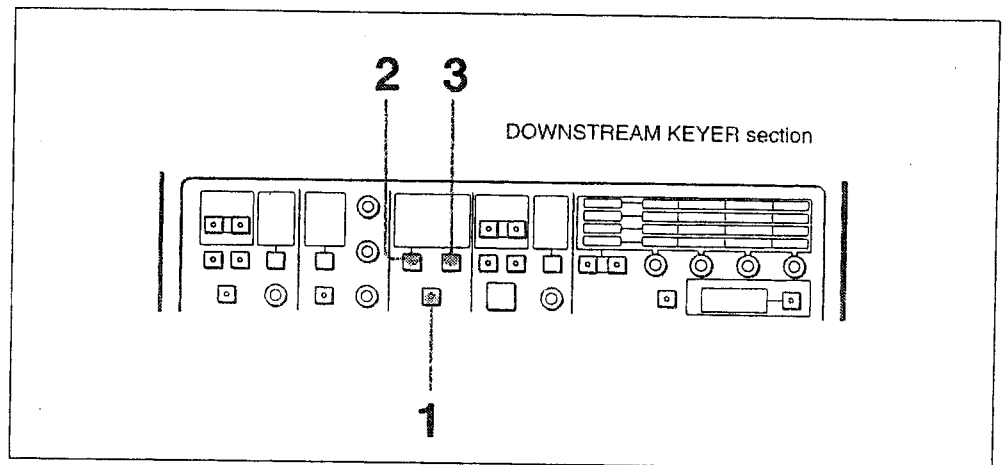

Downstream key – Adding a border

- 1** Press the **BORDER** button to turn on the indicator of the button.
- 2** Press the **TYPE** button to select the type of border.
The corresponding indicator lights.
WIDE BORD: A wide border
NARW BORD: A narrow border
DROP BORD: A drop border like shadowing
DOUBLE: A double border (combination of a narrow border and drop border)
- 3** When you select a drop border or double border, press the **POSITION** button to select the position of the border.
The corresponding indicator lights.
TOP LEFT: The border is extended toward the top left.
TOP RIGHT: The border is extended toward the top right.
BTM RIGHT: The border is extended toward the bottom right.
BTM LEFT: The border is extended toward the bottom left.

Note

When you select a wide border or narrow border, the position cannot be selected. If you press the **POSITION** button, a warning sound is heard, and the indicator does not light.

To make the border disappear

Press the **BORDER** button to turn off the indicator of the button.

Masking a part of the inserted characters or figures

You can mask unnecessary part of the inserted characters or figures.

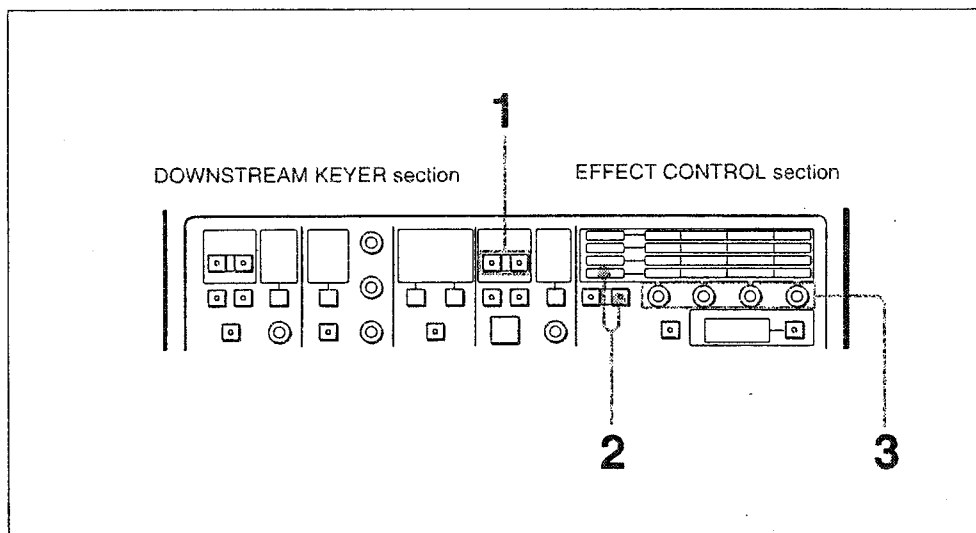

Downstream key — Masking

- 1** Press one of the MASK buttons.
The indicator of the pressed button lights.
NORMAL button: To mask the outside of the specified rectangular area
INVERT button: To mask the inside of the specified rectangular area
- 2** Check that the indicator of the DSK button and the MASK indicator in the EFFECT CONTROL section light.
If the indicators are not lit, press the DSK button to turn on the indicators.
- 3** Turn the parameter-setting controls to set the rectangular area.
Each control from left to right, adjusts the left, right, top and bottom of the area respectively.

To stop masking

Press the MASK button again to turn off the indicator of the button.

Setting the Transition

Setting the Duration of the Transition

The duration of the transition is set in units of frames (thirtieths of a second), which allows automatic transition of pictures at various desired speeds. For a downstream key, the duration to insert characters or figures can be set as desired. When the duration is set to 0, they are inserted and removed instantaneously.

Operation

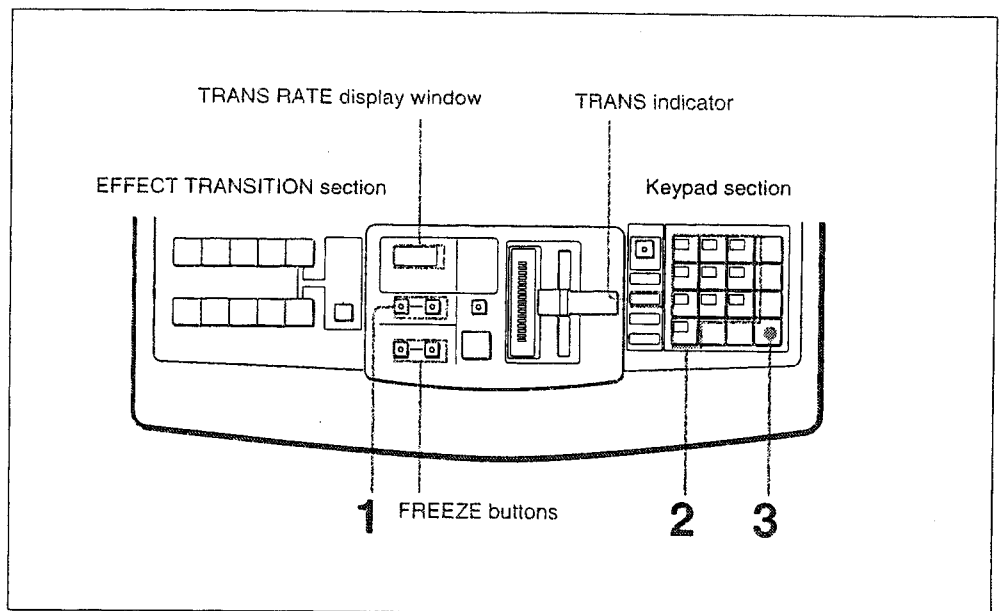

Setting the duration of the transition

- 1** Activate the transition duration setting mode as follows.
To set the duration of the transition for the effect, press the EFFECT button to turn on the indicator of the button.
To set the duration of the transition for downstream key, press the DSK button to turn on the indicator of the button.
The EFFECT or DSK indicator and the TRANS indicator in the keypad section light.

Note

If the indicator of the EDIT button in the USER PROGRAM section is lit, press the EDIT button to turn off the indicator

- 2** Press the numeric buttons to enter the desired duration from 0 to 999 frames. The entered value appears in the TRANS RATE display window. While entering the value, dots appear at the lower right of the digits. The entered value can be changed with the UP or DOWN button.
- 3** Press the ENTER button.
The dots at the lower right of the digits disappear, and the entered value is activated as the duration of the transition.

Setting the Transition

Selecting the Direction of the Transition

Normally for a transition-type effect, a foreground picture is gradually inserted over a background picture, which is finally replaced by the foreground picture (normal direction).

When you press the REVERSE button and the indicator of the button lights, the direction of the transition is reversed, and the background picture gradually goes out and is replaced by the foreground picture (reverse direction).

If you press the REVERSE button again, the indicator of the button goes out, and the effect will be executed in the normal direction.

For an animation-type effect, a foreground picture moves back and forth on a background picture. Every time an effect is executed, the direction is automatically changed. When the indicator of the REVERSE button is not lit, the effect is executed in the normal direction, and after execution, the indicator lights.

When the indicator of the REVERSE button is lit, the effect is executed in the reverse direction, and after execution, the indicator of the button goes out.

While executing an animation-type effect, the NORM/REV indicator lights. If the controller select switch on the internal board is set to BVE-600/RM-450, the indicator does not light.

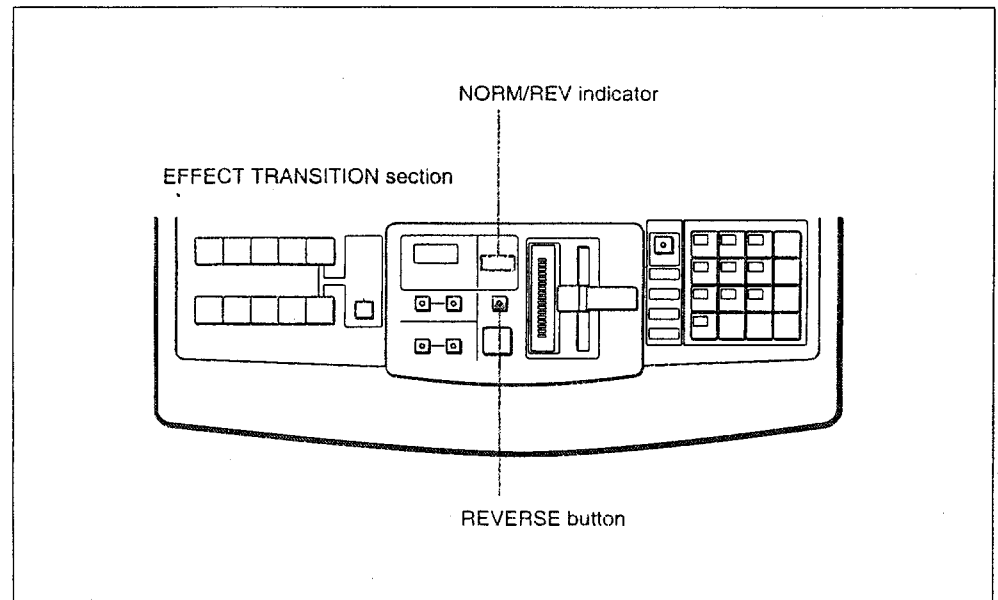

Direction of the transition

Transition-type effect

Normal direction (the indicator of the REVERSE button not lit)

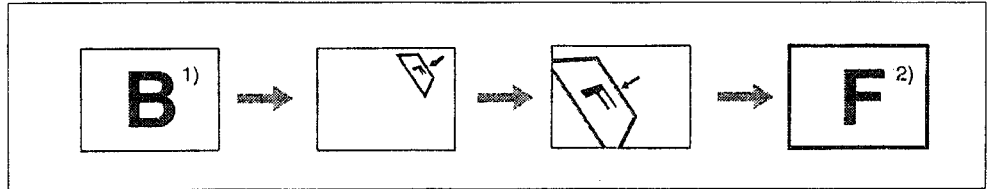

Normal direction of the transition-type effect

Reverse direction (the indicator of the REVERSE button lit)

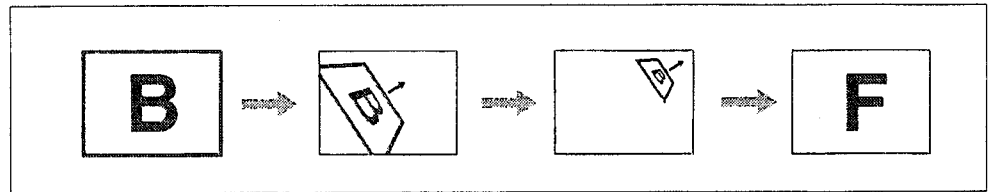

Reverse direction of the transition-type effect

Animation-type effect

Normal direction (the indicator of the REVERSE button not lit)

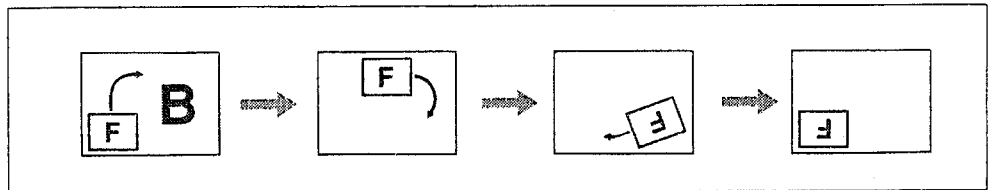

Normal direction of the animation-type effect

Reverse direction (the indicator of the REVERSE button lit)

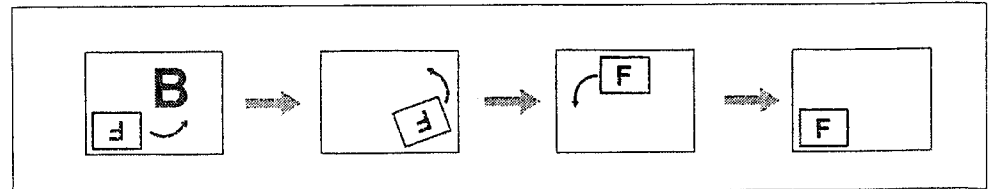

Reverse direction of the animation-type effect

For the motion type of each effect, see "Effects Classified by Type of Motion" on page A-10.

-
- 1) B: Background picture
 - 2) F: Foreground picture

Executing the Effect

You can execute the effect using the fader lever or the AUTO TRANS button after selecting the direction of the transition.

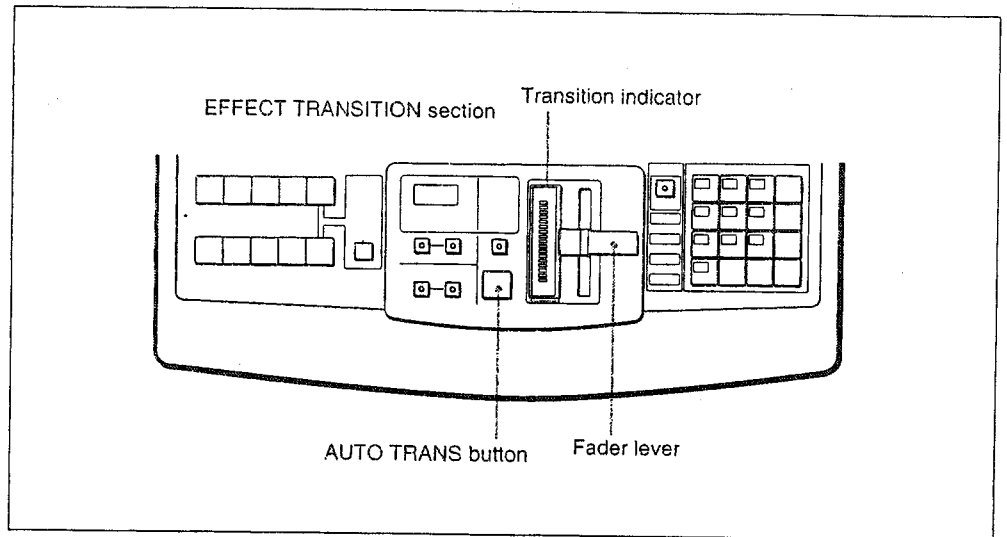

Executing using the fader lever

The fader lever allows you to manually control the transition of the effect. Move the fader lever from one end to the other at the desired speed. As the lever moves, the transition indicator to the left of the lever lights. When the effect whose duration of transition is 0 is to be executed, the effect is executed at the center position of the lever.

To momentarily stop the transition

Stop moving the fader lever.

To resume the transition

Move the fader lever again.

Note

After turning the power on, move the fader lever from one end to the other. Then the fader lever is activated.

Executing using the AUTO TRANS button

Press the AUTO TRANS button, and the effect is automatically executed with the duration set for the transition.

While executing the effect, the pressed button is lit, and when execution ends, the button goes out.

When the duration of the transition is set to 0, the effect is executed as soon as you press the button.

To momentarily stop the transition

Press the AUTO TRANS button to turn off the button.

Note

If the fader lever has been placed at the position in between, the transition momentarily stops at the point corresponding to the fader-lever setting. Not to interrupt the transition, be sure to place the fader lever at the end position.

To resume the transition

Press the AUTO TRANS button again.

Using the fader lever in combination with the AUTO TRANS button

An interrupted transition which was started with the fader lever can be resumed with the AUTO TRANS button, and vice versa.

- When you resume the transition started with the fader lever using the AUTO TRANS button, the duration for the later transition is proportional to the set duration of the transition.
- When you resume the transition started with the AUTO TRANS button using the fader lever, the transition starts again when the lever reaches the position corresponding to the interrupted point.

Executing the Effect

Confirming the direction and transition of the effect

When you start the effect manually or automatically, the transition indicator which is composed of 20 LEDs starts to light from one end. As the transition proceeds, the LEDs light one after another in the direction in which the transition will continue. When the transition is finished, all the LEDs go out.

When the transition is interrupted, the LEDs corresponding to the interrupted position light. You can continue the interrupted transition by moving the lever in the direction where the LEDs are not lit.

The figure below shows that LEDs start to light from upper end and more than half of a transition has been finished.

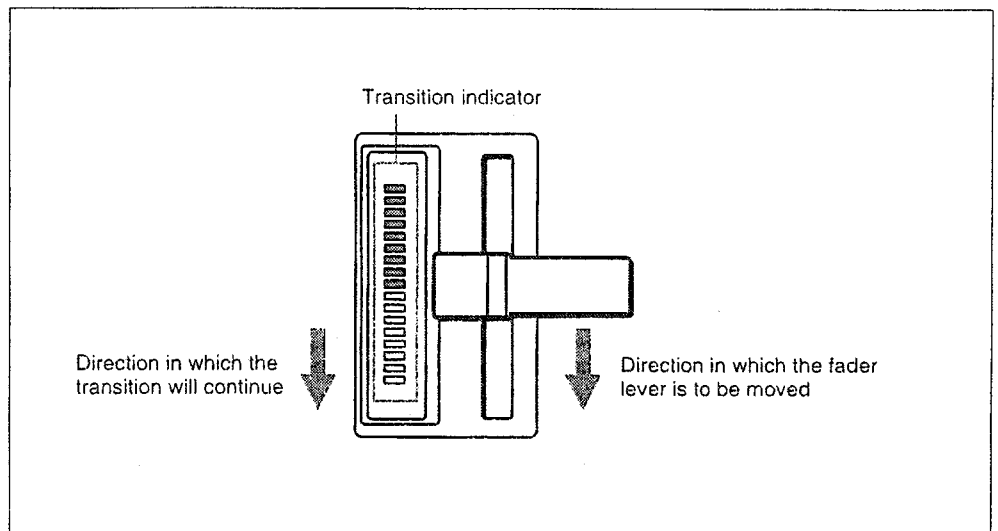

LEDs on the transition indicator



Adjusting the Color Matte

The DFS-500/500P has generators for five color mattes. You can adjust the color of each color matte independently, and the settings can be copied from one color matte to another.

Adjusting the Color

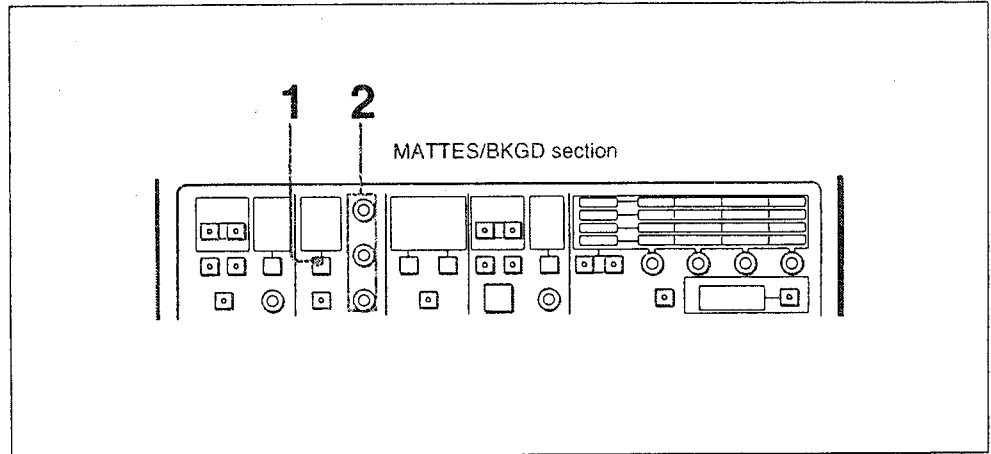

Color matte – Adjusting the color

- 1 Press the SELECT button to select a color matte to be adjusted.

 - COL BKGD (color background):** A color matte used as a foreground picture, background picture or a picture which appears during transition
 - BORD MAT (border matte):** A color matte used for a border added to an effect pattern, characters or figures cut with a title key, or compound effects
 - SHAD MAT (shadow matte):** A color matte used for a compound effect added to an effect pattern, or characters or figures cut with a title key
 - DSK MAT (downstream key matte):** A color matte used for characters or figures cut with a downstream key
 - DSK BORD (downstream key border):** A color matte used for a border for a downstream key
- 2 Turn the HUE, SAT and LUM controls to adjust the hue, saturation and luminance.

Note

When you turn the LUM control with the color-matte signal set to high luminance, the luminance value is automatically compensated so that the signal level does not exceed the specified level.

Adjusting the Color Matte

Copying the Color-Matte Data

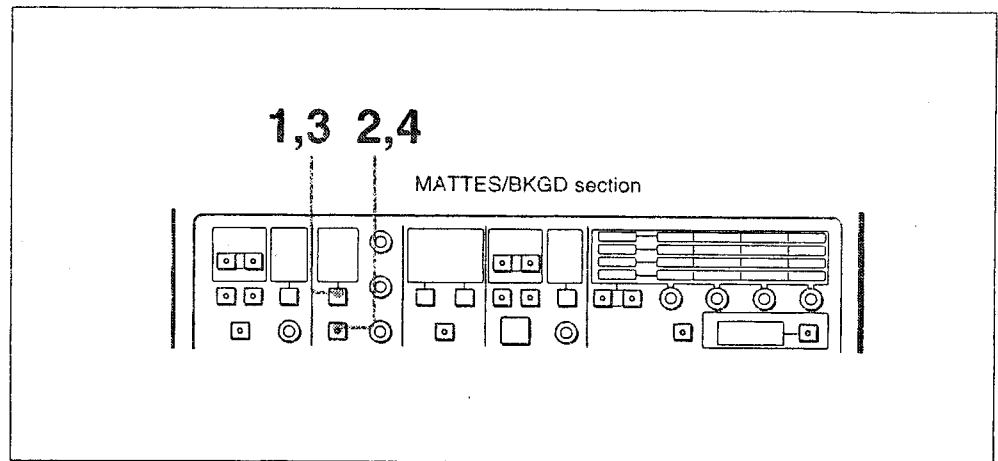

Copying the color-matte data

- 1** Press the SELECT button to select the color matte whose data is to be copied. The corresponding indicator lights.
- 2** Press the MATTE COPY button to turn on the indicator of the button. The color matte data can now be copied.
- 3** Press the SELECT button to select the color matte onto which the data is to be copied. The indicator corresponding to the selected color matte lights, and the indicator of the color matte selected in step 1 starts flashing.
- 4** Press the MATTE COPY button again. The indicator of the button goes out, and the data is copied. The same color as that of the color matte selected in step 1 is set for the color matte selected in step 3.

To stop copying

In step 3, select the same color matte selected in step 1, and press the MATTE COPY button.

Chapter 6

Advanced Operation

This chapter explains a variety of functions using memory to suit the DFS-500/500P for your purpose.

Changing the Direct Pattern Assignment	6-2
User Program	6-4
Required Conditions for User-Program Effects	6-4
Creating a User-Program Effect	6-10
Editing a User-Program Effect	6-12
Executing a User-Program Effect	6-18
Deleting a User-Program Effect	6-19
Snap Shot	6-20
Storing the Snap Shot Data	6-21
Recalling the Snap Shot	6-22

Changing the Direct Pattern Assignment

You can change the assignment of the effect patterns to the numeric buttons (0 through 9) in the keypad section as desired so that patterns which you frequently use may be obtained in direct pattern select mode (direct pattern assign function). Assignment to the INS, DEL and RST buttons cannot be changed.

Operation

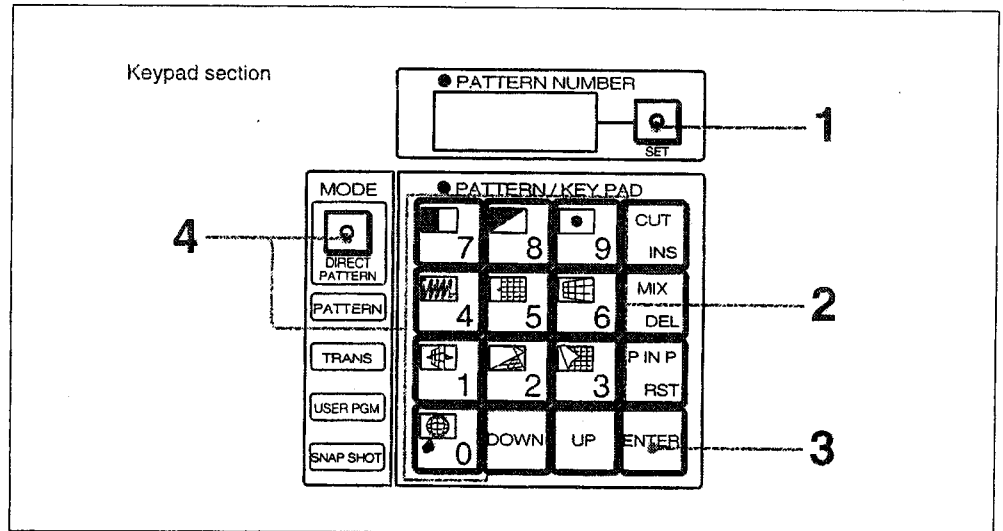

Changing the direct pattern assignment

- 1** Press the SET button.
The indicator of the button and the PATTERN indicator of the mode indicators light, and pattern number assign mode is obtained.
- 2** Press the numeric buttons to enter the pattern number to be assigned to one of the buttons.
The PATTERN NUMBER display window shows the entered number.
- 3** Press the ENTER button.
- 4** Press the numeric button whose assignment is to be changed while holding down the DIRECT PATTERN button.
The pressed numeric button and the pattern number displayed in the PATTERN NUMBER display window flash three times, and the pattern number entered in step 2 is assigned to the button.

Recalling the original assignment (initializing the direct pattern assignment)

The assignment at the factory (see page 5-5) can be restored with the following procedures. The assignment to all the numeric buttons 0 through 9 is reset.

- 1** If the indicator of the EDIT button in the USER PROGRAM section is lit, press the EDIT button to turn off the indicator.
- 2** Press the DIRECT PATTERN button to turn on the indicator of the button.
- 3** Press the DIRECT PATTERN button again while holding down the RST and DOWN buttons of the PATTERN/KEY PAD buttons. A buzzer sounds, and the assignment is initialized.

Replacing labels

The label on a numeric button can be replaced with one of the supplied labels to indicate the new assignment as follows:

- 1** Draw a new pattern image on the supplied label.
- 2** Remove the button whose label is to be changed by inserting a slotted screwdriver into the hole on the side of the button. To remove the button placed at the center, first remove the adjacent buttons.

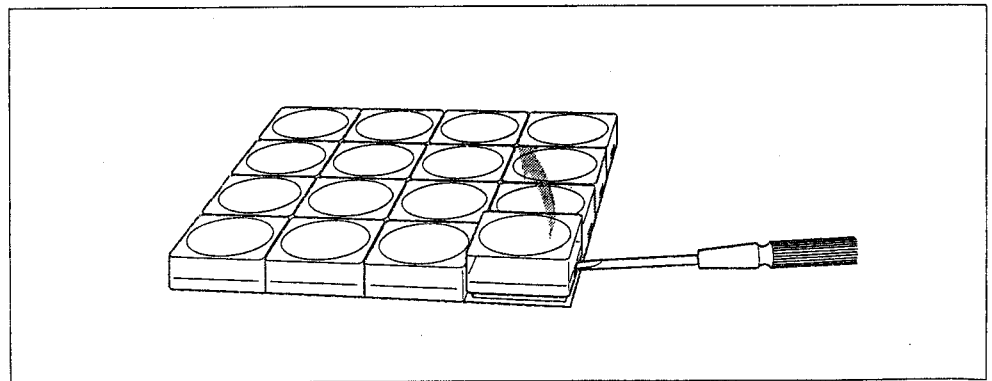

How to remove the button

- 3** Remove the label, and replace it with the new label.
- 4** Replace the button to its original position.

User Program

You can create your own original effect patterns and store up to 40 of them in addition to the built-in effect patterns. These effect patterns are called user-program effects.

The effect patterns created with the user-program function can be executed by designating pattern numbers in the same way as with the built-in patterns.

Required Conditions for User-Program Effects

Construction of the user-program effects

A user program is to register an instantaneous state of the form and motion of a pattern as key frames.

In a user-program effect, up to eight key frames from 1 through 8 can be registered in this order to make a picture selected with the FOREGROUND bus button go off the screen (reverse direction). The created user-program effect is executed from the largest key frame number to the smallest with an equal interval between key frames. You can execute the user-program effect from the smallest key frame by pressing the REVERSE button to turn on the indicator of the button.

When you execute a user-program effect, smooth transition between key frames is available by automatically creating the motion with the spline compensation function. The smoothness of the transition (spline curve) can be adjusted with the EFFECT CONTROL section while executing the program.

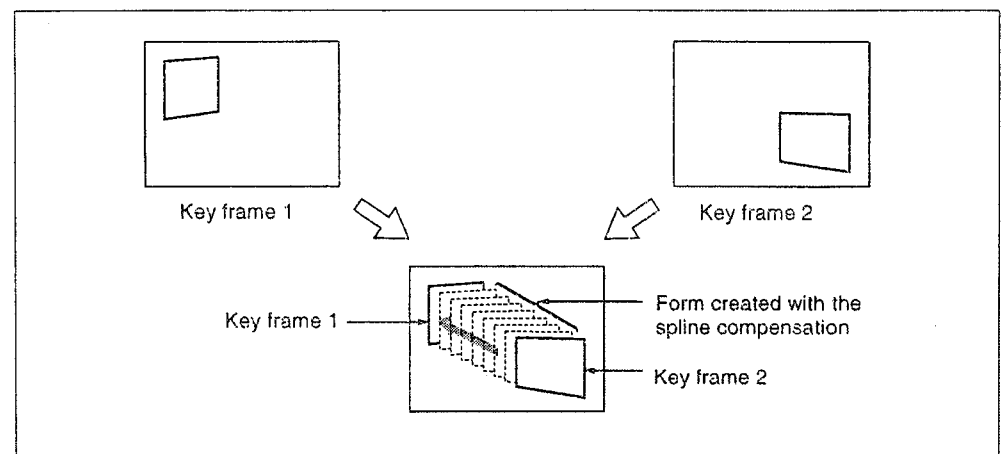

Construction of a user-program effect

When a user-program effect in which only key frame 1 is registered is executed, the form of the key frame 1 appears on a background picture.

Types of user-program effects

Four types of user-program effects are available. Register them to the corresponding numbers as follows.

Types of user-program effects

Type of effect		Pattern number
Linear	Transition	9000 to 9009
	Animation	9100 to 9109
Nonlinear	Transition	9200 to 9209
	Animation	9300 to 9309

Linear type

This type of effects enables the X, Y and Z-axis rotation, expansion, reduction and movement. (For parameters for modifying effect patterns, see page 6-7.)

Nonlinear type

This type of effects enables the page turn, page roll, sphere-type modification, Z-axis rotation, expansion, reduction and movement. (For parameters for modifying effect patterns, see page 6-8.)

Transition type

When this type of effect is executed, a picture is replaced with another, from a background picture (B) to a foreground picture (F).

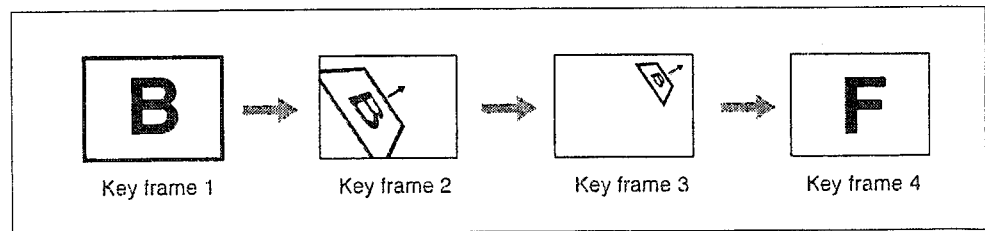

Transition-type effect

When the indicator of the REVERSE button is not lit, the effect registered as above is executed from key frame 4 to 1.

Animation type

A foreground picture (F) is always displayed on a background picture (B), and moves back and forth. Modification or location of a foreground picture can be set.

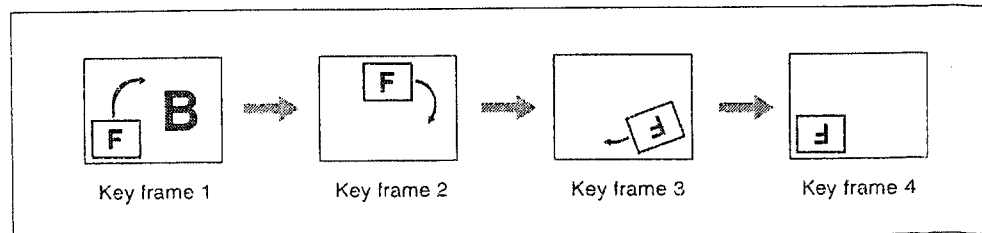

Animation-type effect

When the indicator of the REVERSE button is not lit, the effect registered as above is executed from key frame 4 to 1.

User Program

Parameters for modifying effect patterns

The parameters shown on pages 6-7 and 6-8 can be set to each key frame using the LOCATION and EFFECT CONTROL sections.

When a linear-type user-program effect number is designated, the parameter-setting controls in the EFFECT CONTROL section are set in LINEAR mode, and when non-linear-type user-program number is designated, the controls are set to NON-LIN mode, and the corresponding indicator lights.

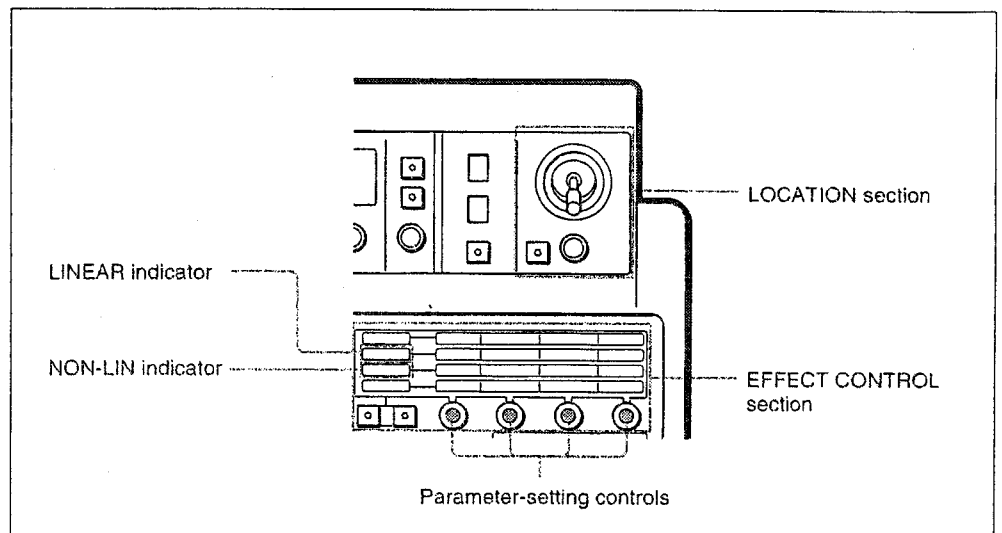

Setting parameters for modifying effect patterns









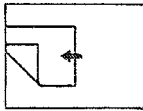
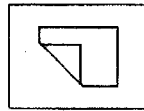
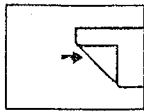
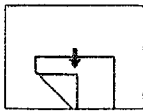

Linear type: 9000 to 9009 and 9100 to 9109

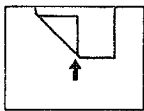
Controls/ parameters	Modified image
(X)/(Y) joystick Movement in the X-axis direction	
(X)/(Y) joystick Movement in the Y-axis direction	
(Z) control Expansion, reduction	
ROT (X) control X-axis rotation	
ROT (Y) control Y-axis rotation	
ROT (Z) control Z-axis rotation	
PERS control Perspective	

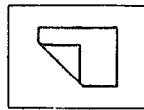
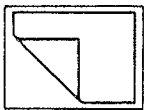
Parameter for modifying linear-type effect patterns

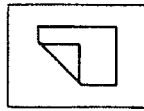
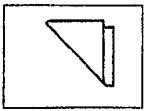
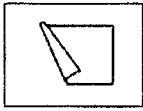
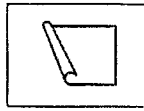
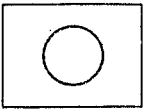
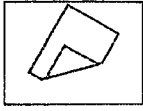
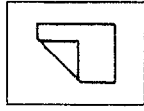
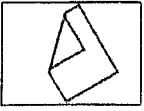
User Program

Nonlinear type: 9200 to 9209 and 9300 to 9309

Controls/ parameters	Modified image		
(X)/(Y) joystick Movement in the X-axis direction			
(X)/(Y) joystick Movement in the Y-axis direction			
(Z) control Expansion, reduction			
OFFSET control Degree of modification			
FORM control Type of modification	 Page turn	 Page roll	 Sphere
ROT (Z) control Z-axis rotation			
ANGLE control Direction of turning			

Parameter for modifying non-linear-type effect patterns

To display the value of parameters

In user-program edit mode (USER PGM indicator lit), the PATTERN NUMBER display window shows the setting value of the corresponding parameter when you press a numeric button in the keypad section. Precise adjustment is possible by referring to the displayed value.

Displayed value of parameters

Parameter	Function	Button to be pressed	Adjustable range	Initial value
LOCATION (X)	Movement in the X-axis direction	7	-5.33 to 5.33 ^{a)}	0.00
LOCATION (Y)	Movement in the Y-axis direction	8	-5.98 to 6.00 ^{b)}	0.00
LOCATION (Z)	Reduction, expansion	9	0.00 to 1.99	1.00
ROT (X)	X-axis rotation	1	-4.00 to 3.99 ^{c)}	0.00
ROT (Y)	Y-axis rotation	2	-4.00 to 3.99 ^{c)}	0.00
ROT (Z)	Z-axis rotation	3	-4.00 to 3.99 ^{c)}	0.00
PERS	Perspective	4	0.50 to 2.00	1.00
OFFSET	Degree of modification	1	0.00 to 1.00	0.00
FORM	Type of modification	2	0 to 7 ^{d)}	0
ROT (Z)	Z-axis rotation	3	-4.00 to 3.99 ^{c)}	0.00
ANGLE	Direction of turning	4	-0.63 to 0.63 ^{c)}	0.13

a) A value of 4.00 means the width of the full screen.

b) A value of 3.00 means the height of the full screen.

c) A value of 1.00 means 360°.

d) The following modifications are assigned to numbers, FORM 0 through 7.

0	Page turn (radius for turning: small)	4	Page roll (radius for rolling: medium)
1	Page turn (radius for turning: medium)	5	Page roll (radius for rolling: large)
2	Page turn (radius for turning: large)	6	Page turn (turning in reverse direction)
3	Page roll (radius for rolling: small)	7	Sphere

ANGLE parameter is not activated with FORM 7.

To initialize changed parameters (reset)

Press the RST button to reset all the parameters, and a pattern with no modifications (full screen) appears on the screen.

To initialize a specific parameter, press the RST button while holding down the corresponding numeric button referring to the table "Displayed value of parameters."

To initialize parameters for LOCATION (X), (Y), (Z), press the LOCATION button to turn off the indicator of the button.

To set parameters for location (X), (Y), (Z) again, press the LOCATION button to turn on the indicator of the button.

User Program

Creating a User-Program Effect

You can create an original effect as a user-program effect as follows.

Operation

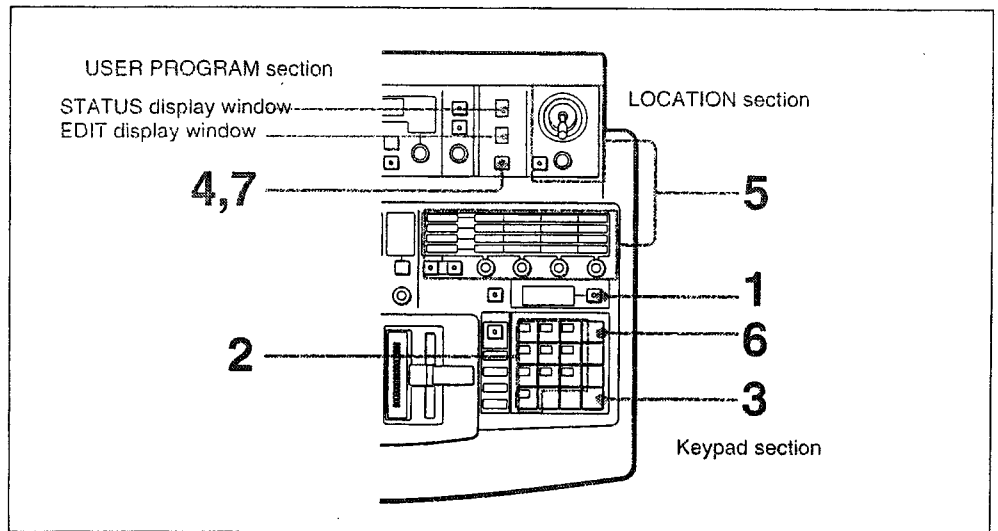

Creating a user-program effect

- 1** Press the SET button.
- 2** Press the appropriate numeric buttons to enter the pattern number for the created user-program effect.
The PATTERN NUMBER display window shows the number.

Type of effect		Pattern number
Linear	Transition	9000 to 9009
	Animation	9100 to 9109
Nonlinear	Transition	9200 to 9209
	Animation	9300 to 9309

- 3** Press the ENTER button.
The STATUS display window shows 1.
If the figure other than 1 appears, follow the procedures below.
To delete the user-program effect, follow the steps in "Deleting a specific user-program effect" on page 6-19, then go to step 5.
To modify the user-program effect, see "Editing a User-Program Effect" on page 6-12, and execute the modification.

Note

When you enter a number other than that for a user-program effect, a warning sound is heard in step 4.

- 4** Press the EDIT button.
The indicator of the button lights, and user-program edit mode is selected. The display for key frame 1 (the picture selected with the FOREGROUND bus button) appears on the monitor screen. When you designate a new number, a full screen is registered for key frame 1.
The EFFECT CONTROL section is set to the mode corresponding to the type selected in step 2, and the corresponding mode indicator lights.
LINEAR: When a linear-type effect number (9000 to 9009 or 9100 to 9109) is entered.
NON-LIN: When a non-linear-type effect number (9200 to 9209 or 9300 to 9309) is entered.
- 5** Set the parameters using the LOCATION and EFFECT CONTROL sections. To use the LOCATION section, press the LOCATION button to turn on the indicator of the button.
- 6** When you are finished setting the parameters, press the INS button. The set parameters are registered as key frame 2. The EDIT display window shows 2.
When you create an animation-type effect, press the ENTER button instead of the INS button to register the parameters set in step 5 as key frame 1.

Repeat the operation of setting parameters and pressing the INS button as required. You can register up to eight key frames.
The STATUS display window shows the number of the registered key frames.
- 7** Press the EDIT button again when the key-frame setting is finished. The indicator of the button goes out, and the created user-program effect is ready to be executed.

Notes on creating a transition-type user program

- As key frame 1, be sure to register a full screen without any modification. When you designate a new number, a full screen is registered for key frame 1.
- At the last key frame, a background picture should completely disappear from the screen by reducing its size to 0 or by moving it off the screen. Then smooth transition of the effect is available.
- As for the PERS parameter for the linear-type user-program effects, or the FORM parameter for the non-linear-type user-program effects, different values cannot be set for each key frame. The values set for the last key frame are used for all the key frames.

User Program

Editing a User-Program Effect

You can change the value for parameters, or add, delete or copy key frames.

Recalling a user-program effect

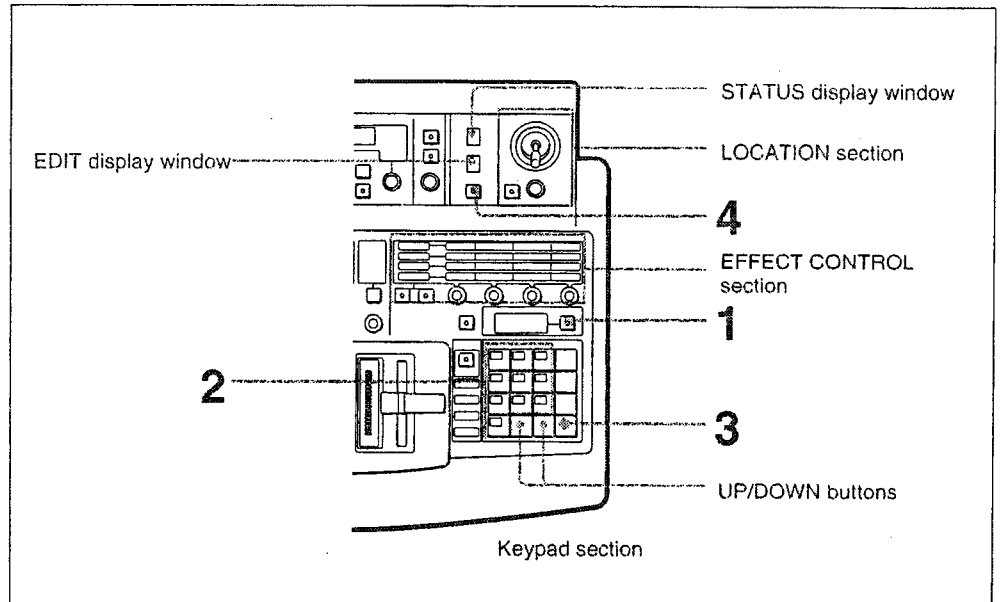

Editing a user-program effect

- 1** Press the SET button.
- 2** Press the numeric buttons to designate the number of the user-program effect to be edited.
The PATTERN NUMBER display window shows the number.
- 3** Press the ENTER button.
- 4** Press the EDIT button.
The indicator of the button lights, and the display (the picture selected with the FOREGROUND bus button) for editing the user-program effect specified in step 2 appears on the monitor screen.
The STATUS display window shows the number of the key frames registered in the designated user program.

Changing the key-frame parameters

Continue the following steps after the steps in "Recalling a user-program effect" mentioned on the previous page.

- 5** Press the UP or DOWN button in the keypad section to designate the key-frame number whose parameters are to be changed and the EDIT display window shows the number.
- 6** Change the parameters using the LOCATION and EFFECT CONTROL sections.
- 7** Press the ENTER button.
The changed parameters are newly registered.

Repeat steps 5, 6 and 7 for all the parameters to be changed.

- 8** Press the EDIT button when you finish all the parameter value changing.
The user-program effect whose parameters is changed are newly registered.

Adding a key frame

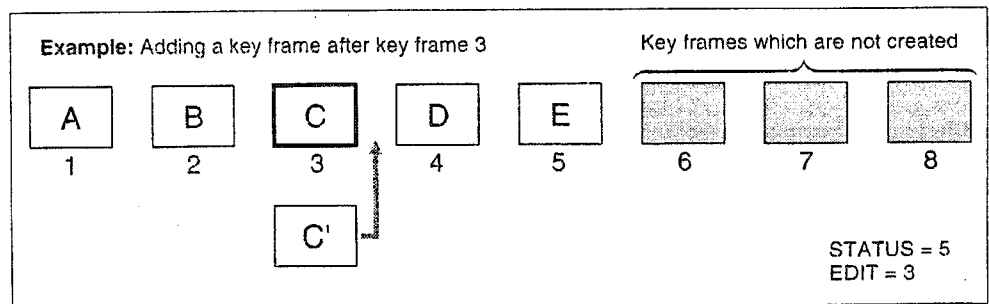

Adding a key frame (before addition)

Continue the following steps after the steps in "Recalling a user-program effect" mentioned before.

- 5** Press the UP or DOWN button in the keypad section to designate the key-frame number just before a new key frame to be inserted (in this example key frame 3).
The EDIT display window shows 3.
- 6** Set the parameters for the key frame to be inserted using the LOCATION and EFFECT CONTROL sections.

(to be continued)

User Program

7 Press the INS button.

A new key frame created in step 6 is inserted after the key frame designated in step 5, and the figure displayed in the STATUS display window increases by one.

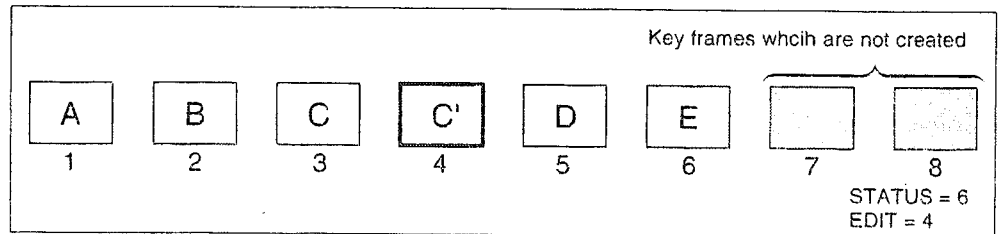

Adding a key frame (after addition)

Repeat steps 5, 6 and 7 as required.

8 Press the EDIT button when you finish adding key frames.

The user-program effect to which you have added new key frames is registered.

Deleting a key frame

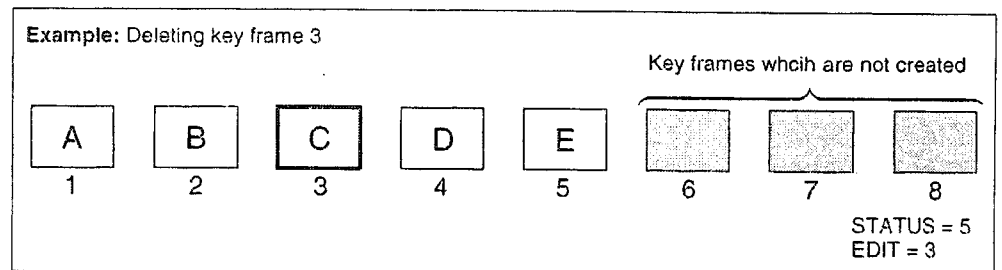

Deleting a key frame (before deletion)

Continue the following steps after the steps in "Recalling a user-program effect" on page 6-12.

5 Press the UP or DOWN button in the keypad section to designate the key-frame number to be deleted (in this example, key frame 3). The EDIT display window shows 3.

- 6** Press the DEL button for more than 0.5 second to avoid unintentional deletion of a key frame.
A buzzer sound, and the key frame designated in step 5 is deleted. The number of key frames displayed in the STATUS display window decreases one.

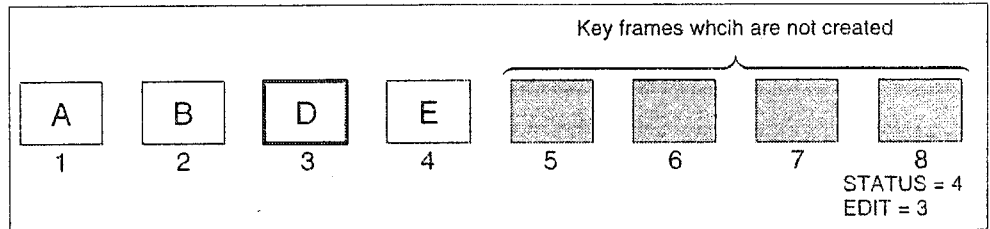

- 7** Press the EDIT button when you finish the deletion.
The user-program effect from which you have deleted a key frame is registered.

Assigning the key-frame data to a numeric button (registration function)

The key-frame data can be temporarily assigned to a numeric buttons from 0 through 9 in the keypad section. The data for the linear-type effects and non-linear-type effects can be assigned respectively so that up to 20 sets of key-frame data can be stored.

The assigned key-frame data can easily be recalled just by pressing the corresponding numeric button, and this can also be used when you wish to change or add a key frame.

To assign the key-frame data

- 1** Press the EDIT button to select user-program edit mode.
- 2** Set the data for a key frame using the EFFECT CONTROL and LOCATION sections.
- 3** Press the ENTER button while holding down one of the numeric buttons in the keypad section.
The pressed button lights, and the key-frame data set in step 2 is assigned to the button.

User Program

To recall the assigned key-frame data

Press the ENTER button while holding down one of the lit numeric buttons in the keypad section in user-program edit mode.

The pressed button goes out, and the key-frame data assigned to the pressed button is recalled.

Notes

- When the assigned data is recalled, the data is automatically cleared. If you want to retain the data, assign it again.
- A key-frame data set for a linear-type effect cannot be used for a non-linear-type effect and vice versa.
- The key-frame data assigned to the numeric buttons is automatically cleared when the power of the DFS-500/500P is turned off.

Copying a key frame

Using the registration function for a key frame, the key-frame data can be copied between user-program effects.

- 1** (1) Press the SET button in the keypad section to select pattern number designation mode.

(2) Press the appropriate numeric buttons from 0 through 9 to designate the user-program effect number which includes key-frame data to be copied. The PATTERN NUMBER display window shows the designated number.

(3) Press the ENTER button.
- 2** Press the EDIT button to select user-program edit mode. The STATUS display window shows the number of key frames registered in the user-program effect designated in step 1.
- 3** Press the UP or DOWN button in the keypad section until the number of the key frame whose data is to be copied appears in the EDIT display window.
- 4** Press the ENTER button while holding down a numeric button. The pressed numeric button lights, and the key-frame data selected in step 3 is assigned to that button.
- 5** Press the EDIT button to release user-program edit mode.
- 6** (1) Press the SET button in the keypad section to select pattern number designation mode.

(2) Press the appropriate numeric buttons 0 through 9 to specify the number of the user-program effect onto which the data is to be copied.

(3) Press the ENTER button.
Be sure to select the same type of effect as that whose data is to be copied (linear-type or nonlinear type).
The PATTERN NUMBER display window shows the designated number.

-
- 7** Press the EDIT button to select user-program edit mode.
The STATUS display window shows the number of key frames registered in the user-program effect selected in step 6.
 - 8** Press the UP or DOWN button in the keypad section until the number of the key frame onto which the data is to be copied appears in the EDIT display window.
The display for the designated key frame will appear on the monitor screen.
 - 9** Press the ENTER button while holding down the numeric button on which the key frame data to be copied has been assigned in step 4.
The pressed numeric button goes out, and the key-frame data is recalled.
 - 10** Press the ENTER button again.
The recalled key-frame data is copied onto the designated key frame.
 - 11** When you finish copying the data, press the EDIT button.
The user-program edit mode is released.

Executing a User-Program Effect

You can execute the created user-program effect in the same way as with the built-in effects.

The form between the registered key frames is automatically created by the spline-compensation function. The smoothness of the transition (spline curve) can be adjusted as required.

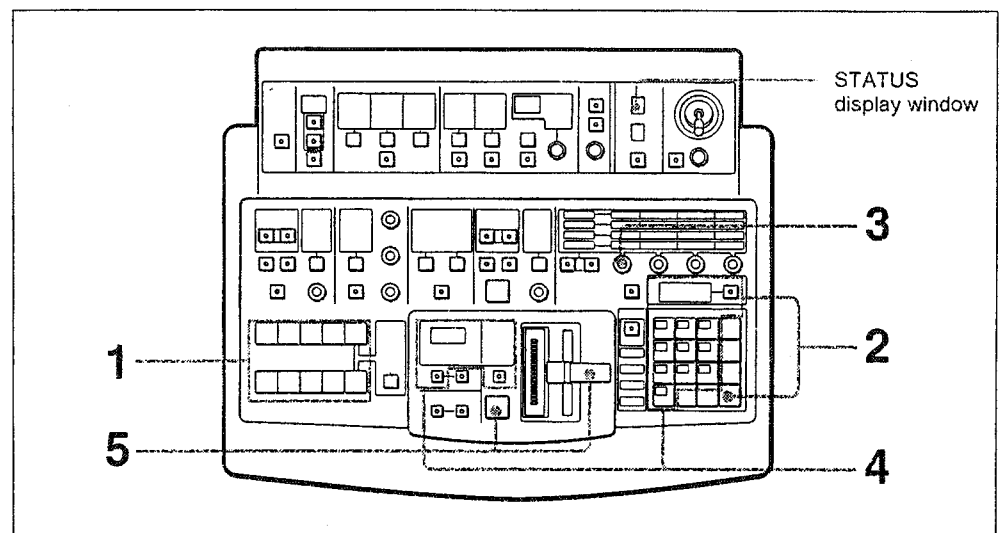

Executing a user-program effect

- 1** Select a background picture and a foreground picture.
- 2** (1) Press the SET button.
(2) Specify the user-program effect number to be executed using the numeric buttons.
(3) Press the ENTER button.
The STATUS display window shows the number of the key frames registered in the designated user program.
- 3** Adjust the smoothness of the key-frame motion with the parameter-setting control (F1) in the EFFECT CONTROL section in MODIFY mode. Turning the control counterclockwise increases the smoothness.
- 4** Set the duration or direction of the transition as required.
- 5** Execute the effect with the fader lever or AUTO TRANS button.

The above procedures are the same as those for executing the built-in effects except for step 3.

For details, see "Executing the Effect" on page 5-34.

Deleting a User-Program Effect

Deleting a specific user-program effect

- 1** (1) Press the SET button in the keypad section to select pattern number designation mode.

(2) Enter the user-program effect number to be deleted with the numeric buttons.

(3) Press the ENTER button.
- 2** Press the EDIT button in the USER PROGRAM section to turn on the indicator of the button.
- 3** Press the DEL button while holding down the RST button in the keypad section for more than 0.5 second to avoid unintentional deletion.
A buzzer sounds, and the key frames registered in the user program are completely deleted. The EDIT and STATUS display windows in the USER PROGRAM section show 1.

Deleting all the user-program effects (initialization)

- 1** (1) Press the SET button in the keypad section to select pattern number designation mode.

(2) Designate any user-program effect number with the numeric buttons. The PATTERN NUMBER display window shows the number.

(3) Press the ENTER button.
- 2** Press the EDIT button in the USER PROGRAM section to turn on the indicator of the button.
- 3** Press the EDIT button again while holding down the RST and DOWN buttons in the keypad section.
A buzzer sounds, and all the user-program effects are completely deleted.

Snap Shot

You can store the setting conditions at the control panel (snap shot data) in the snap shot registers from 0 to 99 in the processor unit. Up to 100 settings can be stored. The data stored in the snap shot registers are called "snap shot." The following settings can be stored for snap shot.

Settings which can be stored for snap shot

Operational section	Settings
Primary crosspoint bus	Selection with the FOREGROUND bus buttons Selection with the BACKGROUND bus buttons Selection with the INT VIDEO SELECT buttons
EFFECT TRANSITION	Duration of the transition Direction of the transition (setting of the REVERSE button) Setting of the FREEZE button
Keypad	Designated pattern number
TITLE	All settings
MATTES/BKGD	Setting for each color matte
DOWNSTREAM KEYER	All settings
EFFECT CONTROL	Settings of parameters for user-modify effects Setting of the smoothness for execution of the user-program effect
EDGE	All settings
LIGHTING	All settings
LOCATION	All settings
TRAIL/SHADOW	All settings

The registered snap shot can be recalled by designating the register number. When the registered data are recalled, all the settings on the control panel are automatically changed according to the recalled data.

Storing the Snap Shot Data

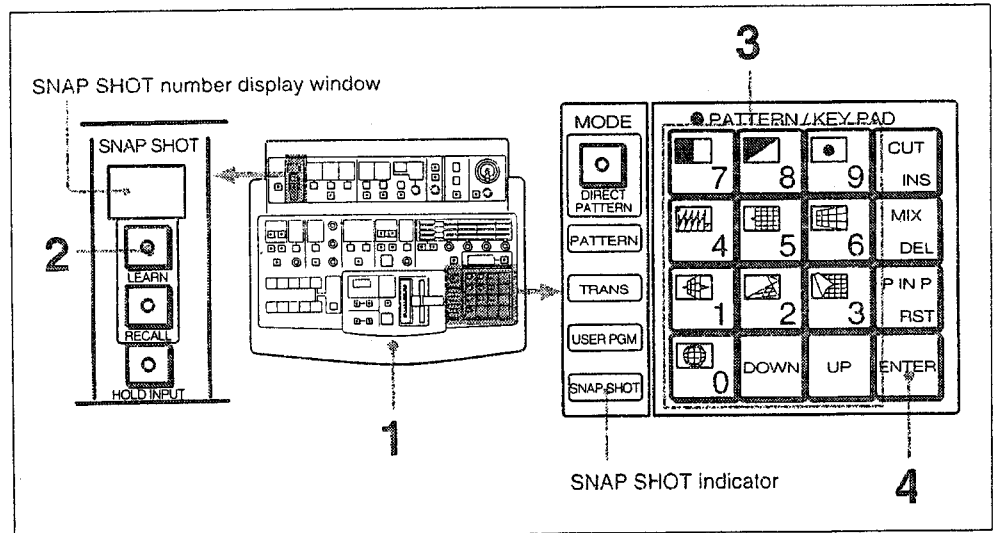

Storing the snap shot data

- 1** Set the buttons and controls on the control panel to the conditions to be stored.
- 2** Press the LEARN button.
The indicator of the button and SNAP SHOT indicator of the mode indicators light (snap shot learn mode).
Dots appear at the lower right of the digits in the SNAP SHOT number display window to indicate that you can enter the numeric data.
- 3** Enter the snap-shot register number to which the data is to be stored using the numeric buttons in the keypad section.
The displayed figure can be changed with the UP or DOWN button.
- 4** Press the ENTER button.
The indicator of the LEARN button and the snap shot number displayed in the SNAP SHOT number display window flash three times, and the current settings on the control panel are stored in the register specified in step 3.
When storing the snap shot data is finished, the indicator of the LEARN button goes out.

To cancel storing the snap shot data

Before pressing the ENTER button in step 4, press the LEARN button again to turn off the indicator of the button.

Snap Shot

Recalling the Snap Shot

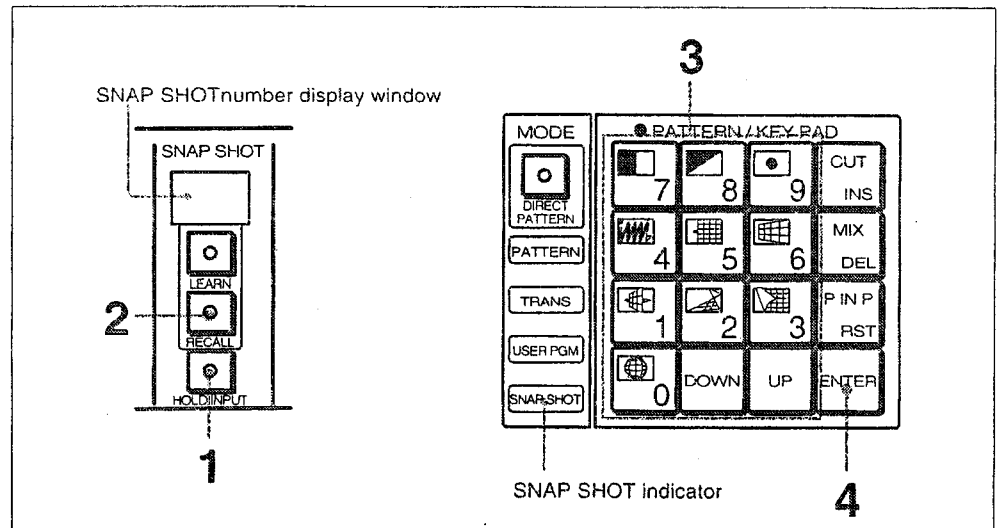

Recalling a snap shot

- 1** If you want to retain the settings in the primary crosspoint bus section, press the HOLD INPUT button to turn on the indicator of the button.
- 2** Press the RECALL button.
The indicator of the button and the SNAP SHOT indicator of the mode indicators light, and the PATTERN/KEY PAD buttons are set to snap shot designation mode.
Dots appear at the lower right of the digits in the SNAP SHOT number display window.
- 3** Enter the snap shot number to be recalled using the numeric buttons.
The displayed number can be changed with the UP or DOWN button.
- 4** Press the ENTER button.
The snap shot data of the designated number is recalled, and the control panel is set according to the recalled snap shot data.
If the HOLD INPUT button is pressed in step 1 and the indicator of the button is lit, the settings in the primary crosspoint bus section do not change.
When the snap shot data is recalled, the indicator of the RECALL button goes out.

To cancel recalling the data

Before pressing the ENTER button in step 4, press the RECALL button again to turn off the indicator of the button.

Demonstration of the snap shot

The registered snap shot can be recalled and the effects stored in the registers can be automatically executed. Use this function to check the data stored in the snap shot registers or for demonstration, the same as with the factory-setting demonstration (see page 4-9.)

To start the demonstration

Press the AUTO TRANS button in the EFFECT TRANSITION section while holding down the numeric buttons **3** and **7** in the keypad section.

The execution of the effects stored in the designated snap shot register when the above-mentioned buttons were pressed, begins, and the effects stored in all the registers will be executed one after another. While the demonstration is being executed, the PATTERN/KEY PAD buttons light up one after another counterclockwise.

- You can retain the setting of the primary bus section by pressing the HOLD INPUT button.
- While the demonstration is being executed, the buttons on the control panel other than the AUTO TRANS button are disabled.

To stop the demonstration

Press the AUTO TRANS button again.

Initializing the snap shot

The snap shot registers are reset to the factory settings by initializing them as follows:

- 1** If the indicator of the EDIT button in the USER PROGRAM section is lit, press the EDIT button to turn off the indicator of the button.
- 2** Press the LEARN button.
- 3** Press the LEARN button again while holding down the RST and DOWN buttons.
A buzzer sounds, and the snap shot registers are reset to the factory settings.

Chapter 7

Control with the Editing Control Unit

This chapter gives the required preparations, settings and conditions when a connected external video equipment such as an editing control unit or video switcher controls the DFS-500/500P.

Refer to the operation manual provided with the connected equipment.

Control from the RM-450	7-2
Control from the BVE-600	7-5
A-roll Editing	7-6
A/B-roll Editing	7-7
Control Using a GPI Signal	7-8
A-roll Editing	7-9
A/B-roll Editing	7-10
Control from the BVE-900 Series	7-12
Control from the BVS-3000 Series	7-14
Interface Functions According to the System Configuration	7-19

Control from the RM-450

With the DFS-500/500P, an A-roll editing system using special effects can be constructed in combination with an RM-450 editing control unit, a recorder and a player.

For the required input and output connections, see "A-roll Editing System Connections" on page 3-7.

The DFS- 500/500P is controlled with the cue signal from the RM-450.

Preparations

On the DFS-500/500P

- Turn the power off, and set the controller select switch on the SY-172 board in the processor unit to BVE-600/RM-450. Then turn the power on again.
- Set the freeze timing switch on the SY-172 board appropriately if necessary. Normally set the switch to 8 (the factory setting), and the picture of the recorder VTR is frozen at three fields before the In point. However the frozen frame may depend on the type of the VTR, so set the switch to the appropriate position while repeating the preview.
- Press the EDITOR ENABLE button on the control panel to turn on the indicator of the button. (When the power is turned on, the indicator automatically lights.)
- Press the FIELD FREEZE button on the control panel to turn on the indicator of the button. If the controller select switch is set to BVE-600/RM-450, the indicator automatically lights when the power is turned on.

On the recorder VTR

- Set the PB, PB/EE selector to PB.
- If the VTR has a built-in TBC, set the VTR to Delayed SYNC mode.

On the RM-450

Set the preroll time for the VTR to five or seven seconds to make the RM-450 output a cue signal one second before the In point.



Signal flow

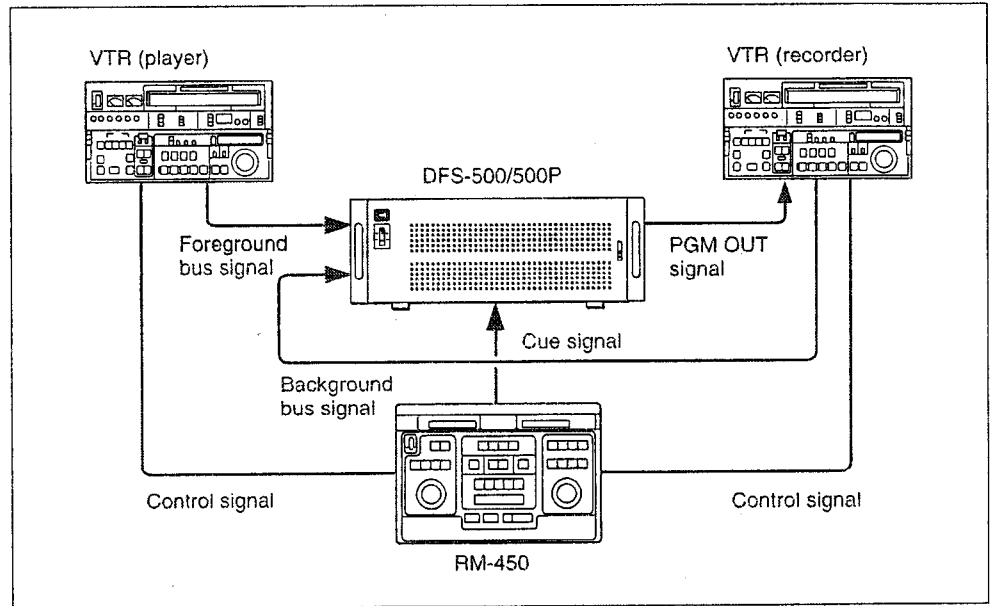

Signal flow

It is recommended to supply the signal (reference sync signal) output from the BLACK BURST OUT connector on the DFS-500/500P to the VTRs and the RM-450 to improve editing accuracy.

Timing of the cue signal

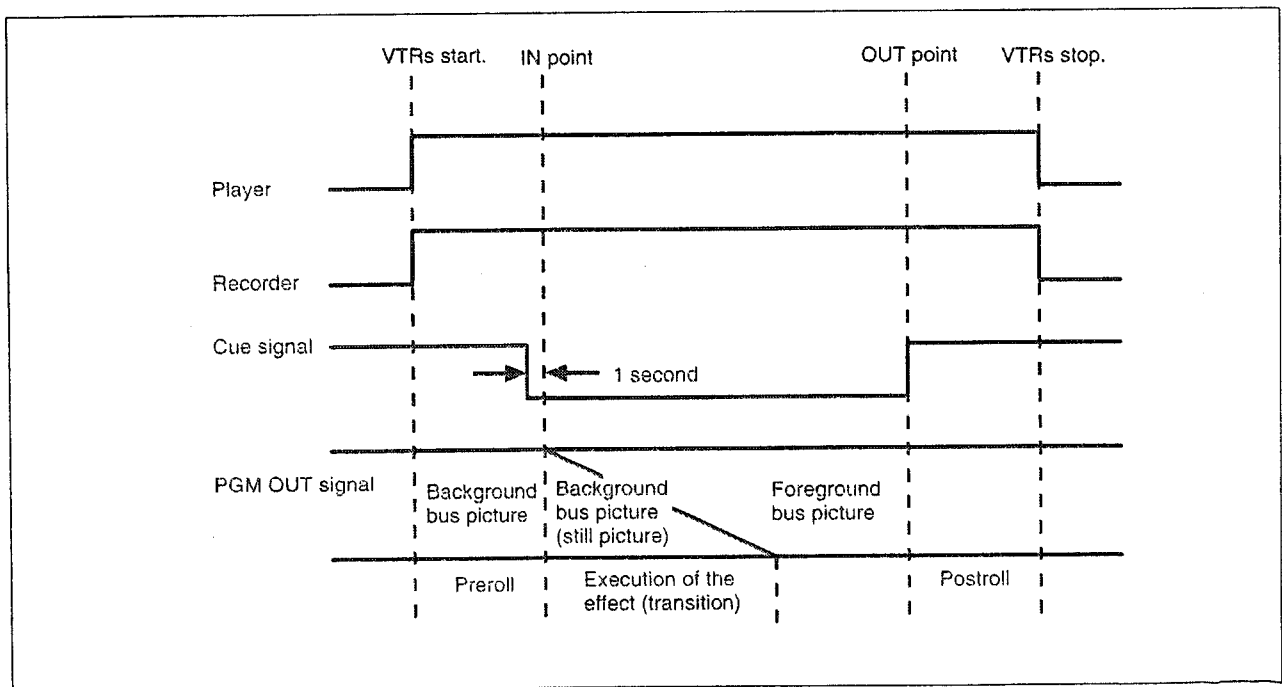

Timing of a cue signal

Control from the RM-450

Basic operation

Please refer to the instruction manual provided with the RM-450.

- 1** Select a picture from the player VTR for the background picture by pressing the BACKGROUND bus button of the DFS-500/500P.
- 2** Decide the In and Out points of the player on the RM-450, monitoring the background picture on the program monitor connected to the DFS-500/500P.
- 3** Change the selection of the picture from the player VTR to the foreground picture by pressing the FOREGROUND bus button of the DFS-500/500P.
- 4** Select a picture from the recorder VTR for the background picture by pressing the BACKGROUND bus button of the DFS-500/500P.
- 5** Decide the In and Out points of the recorder on the RM-450, monitoring the background picture on the program monitor connected to the DFS-500/500P.
- 6** Set the pattern number, transition, etc. on the DFS-500/500P, and check the settings on the program monitor by operating the fader lever or AUTO TRANS button.
- 7** Press the PREVIEW button on the RM-450.
The effect is executed, but recording is not done.
- 8** Press the AUTO EDIT/END button on the RM-450.
The effect is executed. The tapes on the player and recorder run to the preroll point, five or seven seconds before the In point, and run in playback mode. At the In point, a picture from the recorder VTR (a background picture) becomes a still picture, and the effect begins.
The recorder VTR starts recording simultaneously.

Notes

- To display the background picture during or after transition, press the BACKGROUND bus button of the DFS-500/500P.
- The DFS-500/500P has a built-in frame synchronizer. So the actual editing point delays one frame against the edit point of the player VTR set on the RM-450. The edit point on the recorder does not delay.

Example: If the In point of the player VTR is set to 00:00:10:10, recording begins from 00:00:10:09.



Control from the BVE-600

When the BVE-600 editing control unit is used with the DFS-500/500P, an A-roll editing system using a recorder and a player and an A/B-roll editing system using a recorder and two players can be constructed.

The BVE-600 can control the execution of the effects set on the DFS-500/500P using the trigger signals, T1 and T2.

For the required input and output connections, see "A-roll Editing System Connection" on page 3-7, or "A/B-roll system connections – Using the BVE-600/900" on page 3-9.

Note

The built-in switcher of the BVE-600 (BKE-611/612/621/622) cannot be used with the DFS-500/500P.

Preparations

On the DFS-500/500P

- Turn the power off, and set the controller select switch on the SY-172 board in the processor unit to BVE-600/RM-450. Then turn the power on again.
- Press the EDITOR ENABLE button on the control panel to turn on the indicator of the button. (When the power is turned on, the indicator automatically lights.)
- **To execute an effect other than cut with the A-roll editing system, check that the indicator of the FIELD FREEZE button lights.** When the controller select switch is set to BVE-600/RM-450, the indicator automatically lights when the power is turned on.

To execute cut, turn off the indicator of the button.

To execute A/B-roll editing, press the FIELD FREEZE button to turn off the indicator of the button.

On the recorder VTR

- Set the PB, PB/EE selector to PB.
- If the VTR has a built-in TBC, set the VTR to Delayed SYNC mode.

On the BVE-600

Set switch No.3 of the S502 switches and switch No.2 of the S503 switches on the rear panel to their lower position (OFF). (The switch settings are read when the power is turned on. At the factory, all switches are set to their upper position (ON).)

Notes

- To display the background picture during or after transition, press the BACKGROUND bus button of the DFS-500/500P.
- The DFS-500/500P has a built-in frame synchronizer. So the actual editing point delays one frame against the edit point of the player VTR set on the BVE-600. The edit point on the recorder does not delay.

Example: If the In point of the player VTR is set to 00:00:10:10, recording begins from 00:00:10:09.

Control from the BVE-600

A-roll Editing

Signal flow

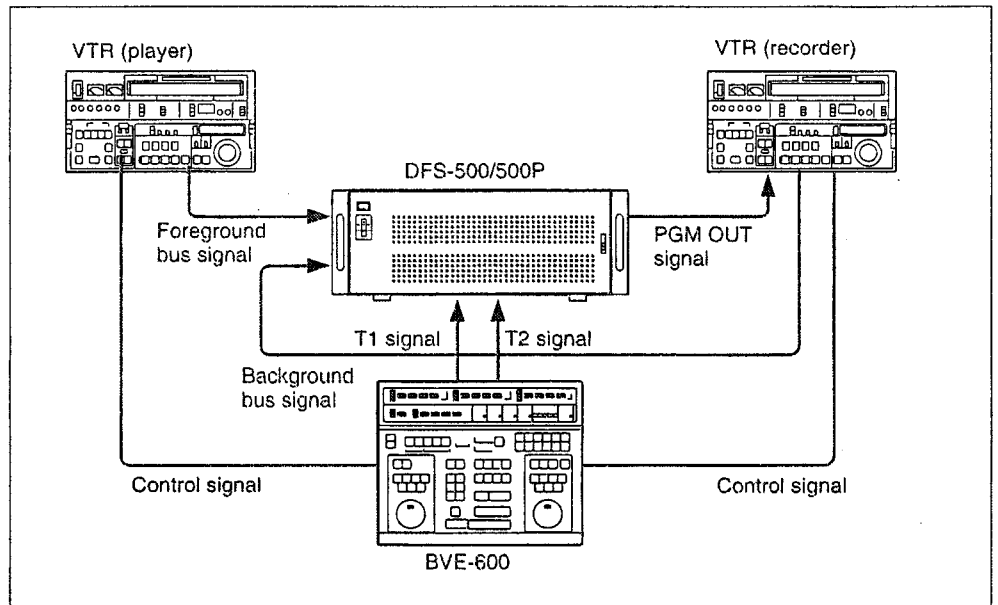

Signal flow

It is recommended to supply the signal (reference sync signal) output from the BLACK BURST OUT connector on the DFS-500/500P to the VTRs and the BVE-600 to improve editing accuracy.

Timing of the trigger (T1/T2) signals

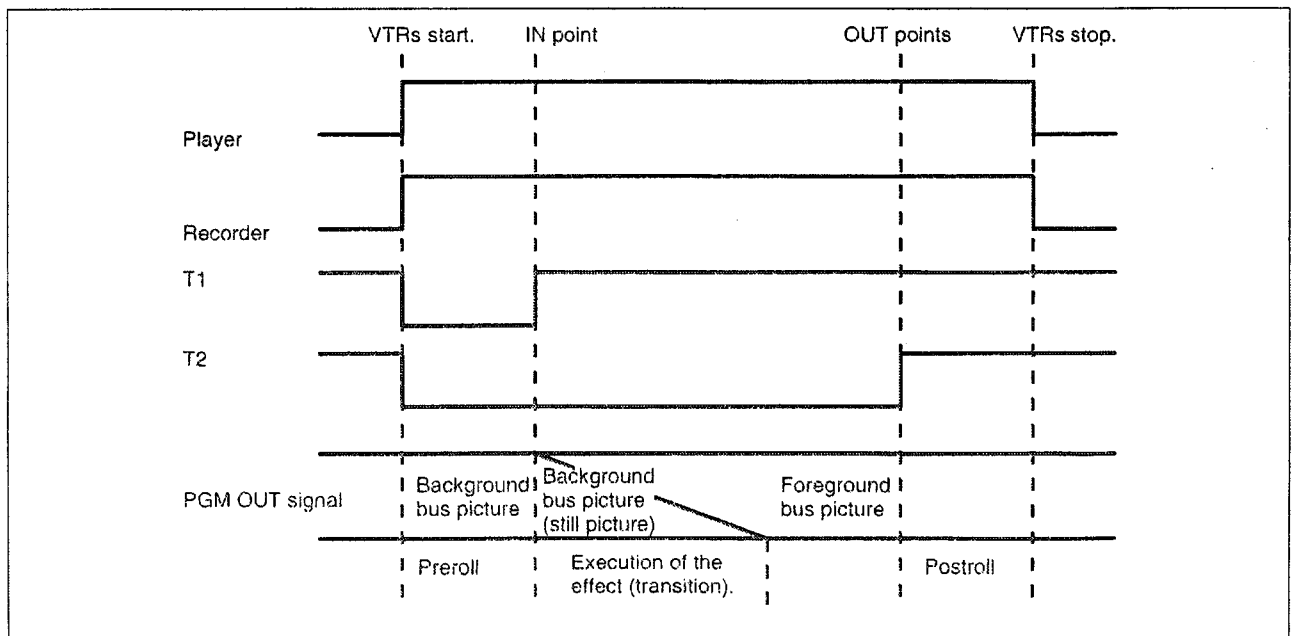

Timing of a trigger signal

A/B-roll Editing

Signal flow

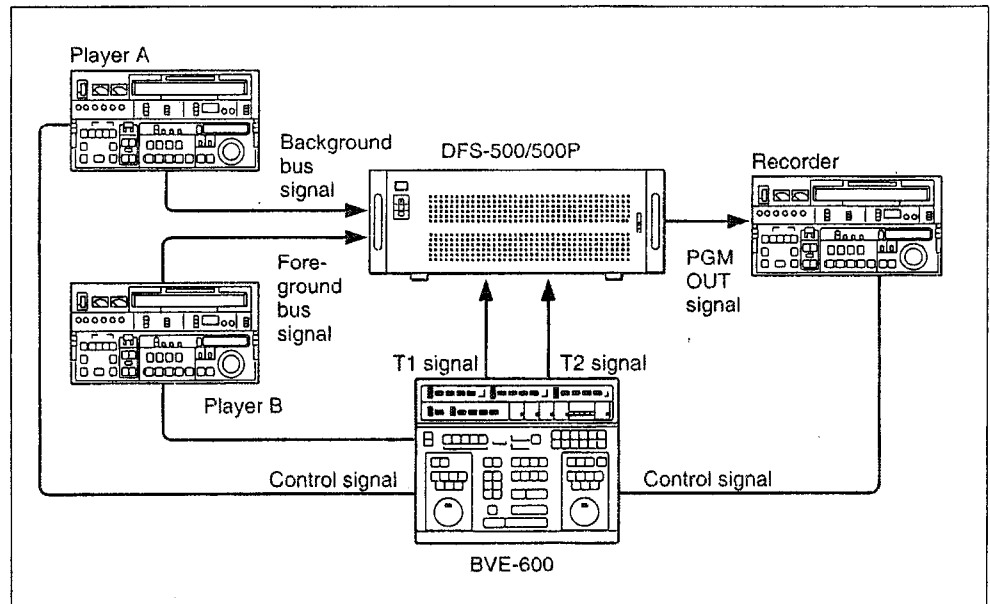

Signal flow

It is recommended to supply the signal (reference sync signal) output from the BLACK BURST OUT connector on the DFS-500/500P to the VTRs and the BVE-600 to improve editing accuracy.

Timing of the trigger (T1/T2) signal

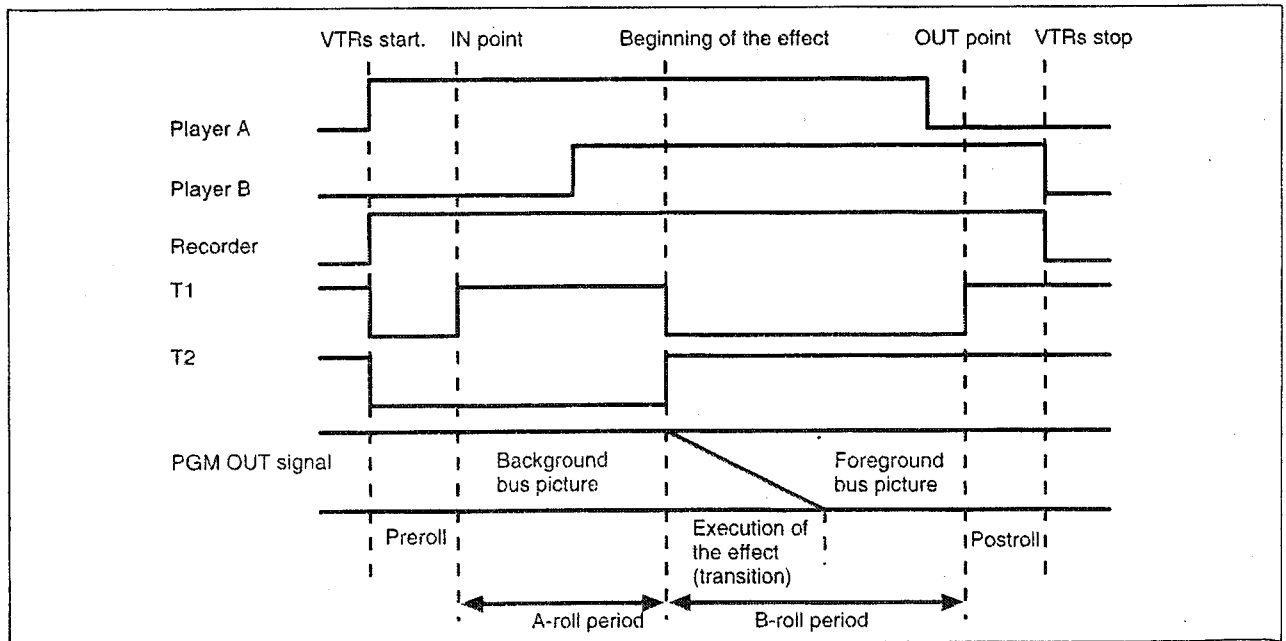

Timing of a trigger signal

Control Using a GPI Signal

When the equipment which outputs a GPI signal is used with the DFS-500/500P, an A-roll editing system using a recorder and a player and an A/B-roll editing system using a recorder and two players can be constructed.

The GPI signal controls the start of the execution of the effects. If two GPI signals are input, the downstream-key function is also controlled with these signals.

For the required input and output connections, see "A/B-roll Editing System Connection – Using the GPI signal" on page 3-8.

Preparations

On the DFS-500/500P

- Turn the power off, and set the controller select switch on the SY-172 board in the processor unit to ONE-GPI. Then turn the power on again.
- To execute an effect in A-roll editing, press the FIELD FREEZE button to turn on the indicator of the button.

On the recorder VTR

- Set the PB, PB/EE selector to PB.
- If the VTR has a built-in TBC, set the VTR to Delayed SYNC mode.

On the editing control unit

Set the timing to output the GPI signal two frames before the In point. (pulse width of a GPI signal: more than one frame)

Notes

- To display the background picture during or after transition, press the BACKGROUND bus button of the DFS-500/500P.
- The DFS-500/500P has a built-in frame synchronizer. So the actual editing point delays one frame against the edit point of the player VTR set on the connected equipment. The edit point on the recorder does not delay.

Example: If the In point of the player VTR is set to 00:00:10:10, recording begins from 00:00:10:09.

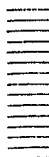

A-roll Editing

Signal flow

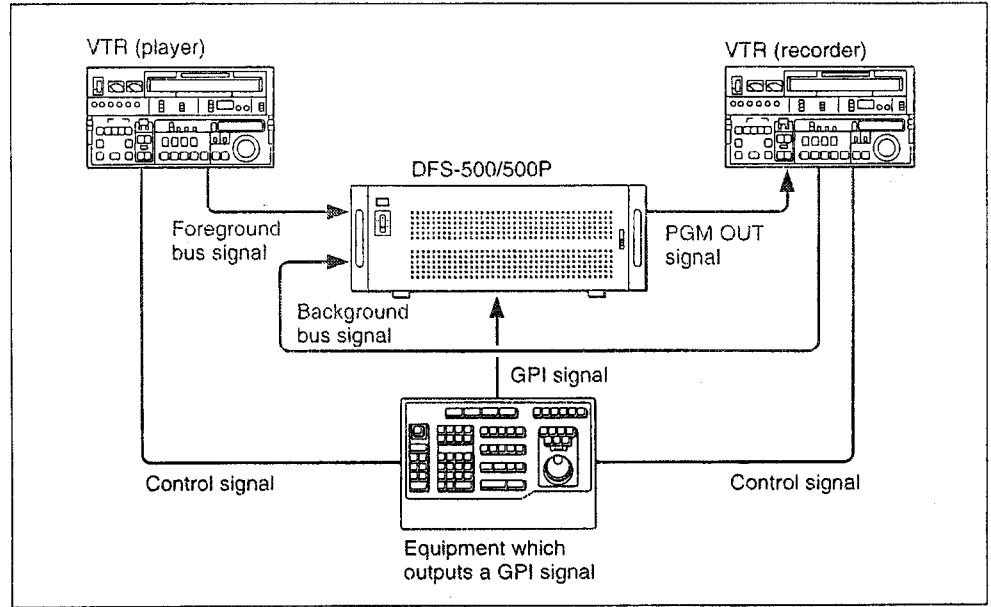

Signal flow

It is recommended to supply the signal (reference sync signal) output from the BLACK BURST OUT connector on the DFS-500/500P to the VTRs and the editing control unit to improve editing accuracy.

Timing of the GPI signal

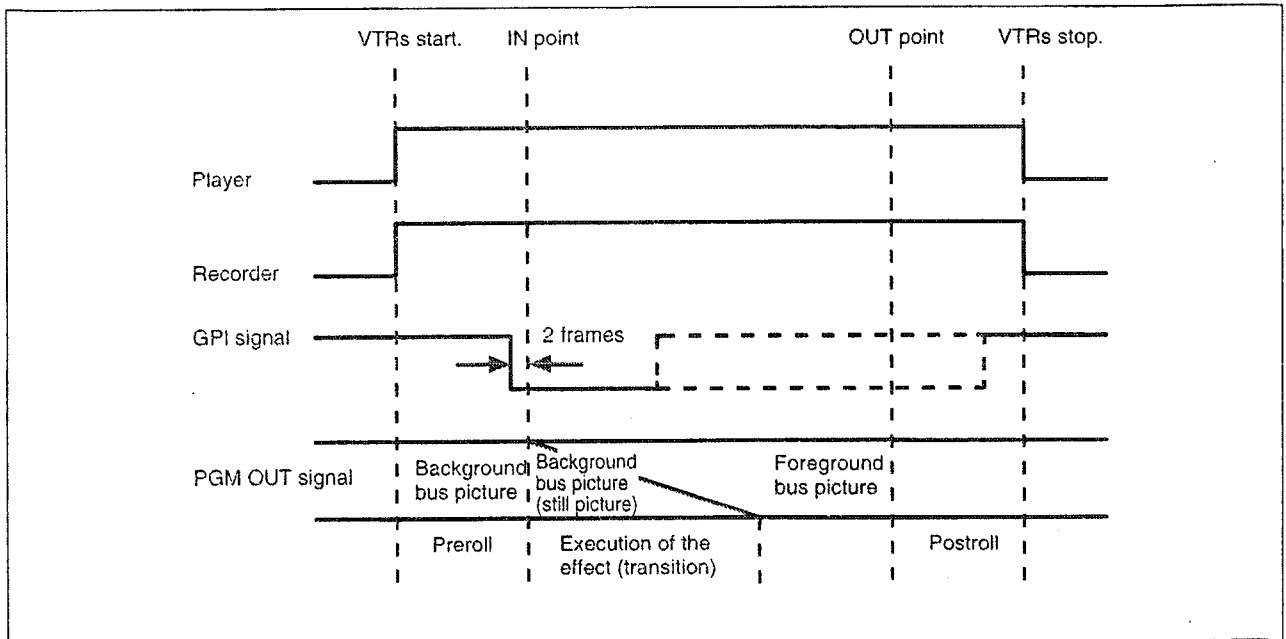

Timing of a GPI signal for A-roll editing

Control Using a GPI Signal

A/B-roll Editing

Signal flow

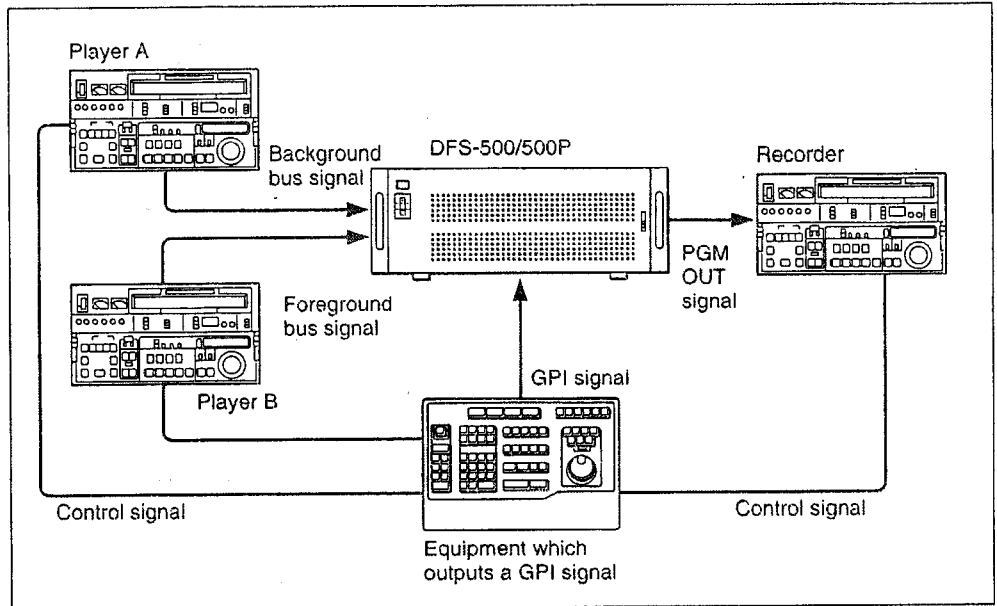

Signal flow

It is recommended to supply the signal (reference sync signal) output from the BLACK BURST OUT connector on the DFS-500/500P to the VTRs and the editing control unit to improve editing accuracy.

Timing of the GPI signal

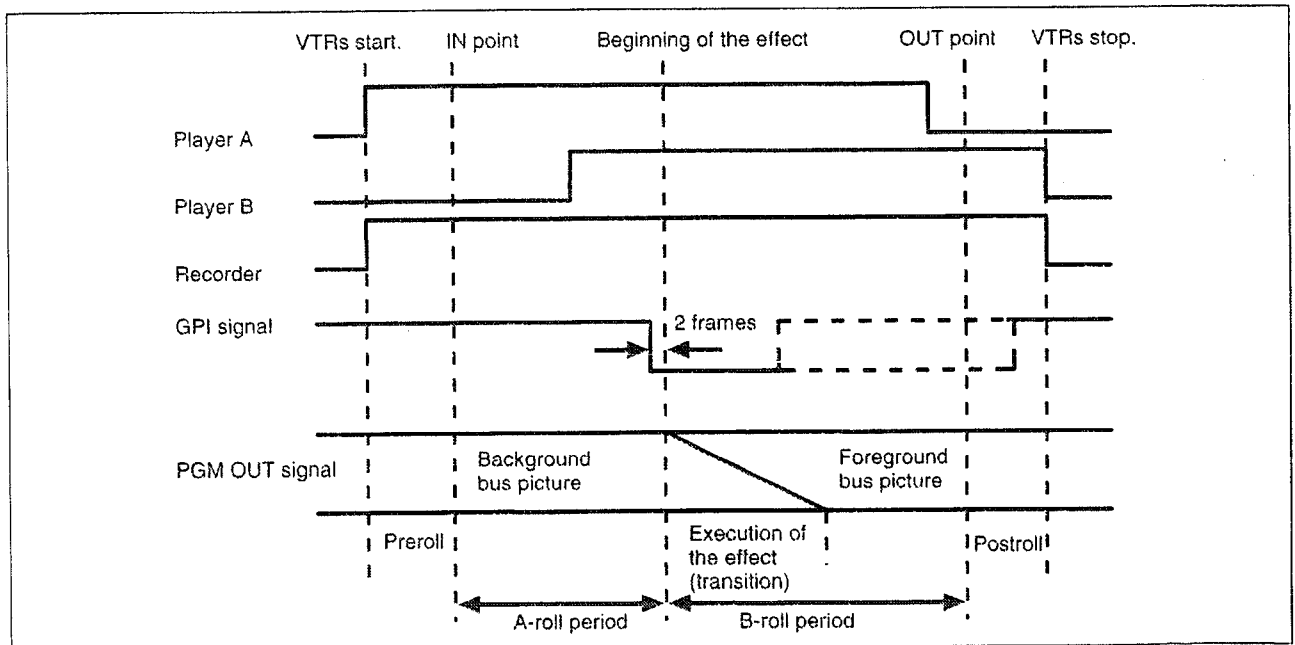

Timing of a GPI signal for A/B-roll editing

Controlling a downstream key

When the controller select switch is set to ONE-GPI, another GPI signal input to the T2 connector on the DFS-500/500P turns on and off a downstream key at the trailing edge of the GPI signal.

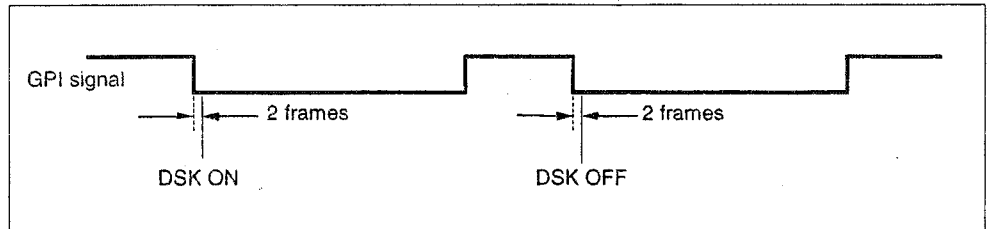

Timing to turn on and off a downstream key

Control from the BVE-900 Series

When the BVE-900 or BVE-910 editing control unit is used with the DFS-500/500P, an A/B-roll editing using two players and a recorder is available.

For the required input and output connections, see "A/B-roll system connections - Using the BVE-600/910" on page 3-9.

The following functions of the DFS-500/500P are controlled with the control signal sent from the BVE-900/910.

- Selecting a background picture and foreground picture
- Designating a pattern number
- Selecting the direction of transition (NORM/REV)
- Setting the duration of transition
- Executing the automatic transition (AUTO TRANS)
- Storing and recalling a snap shot (LEARN/RECALL)
- Saving and loading a user-program data and snap shot data (SAVE/LOAD)

The 9-pin serial control signal or the GPI signal output from the BVE-900/910 also controls the downstream-key function of the DFS-500/500P. To control it with the GPI signal, input the GPI signal from the BVE-900/910 to the T2 connector of the DFS-500/500P. Then the downstream-key function is turned on and off at the trailing edge of the GPI signal.

When the power of the DFS-500/500P is turned on, the indicator of the EDITOR ENABLE button lights, and the control with both the 9-pin serial control signal and the GPI signal is enabled.

If you want to use either of them, proceed as follows:

To turn on and off the GPI signal only, press the EDITOR ENABLE button while holding down the SHIFT button. The indicator of the EDITOR ENABLE button shows whether the GPI signal is turned on or off while the SHIFT button is pressed.

To turn on and off the 9-pin serial control signal only, press the EDITOR ENABLE button.

To control the DFS-500/500P from the BVE-900 series, use the BVE-900, BVE-910 or BKE-913 (optional) with the appropriate ROM version as shown below.

BVE-900	V1.11 or higher
BVE-900 with BKE-900K	V2.01 or higher
BVE-910	V1.02 and higher
BKE-913	V1.06 or higher

Note

The BVE-900 with the BKE-900K editor expansion is used in the same way as the BVE-910. However, when the BKE-900K is not installed, some operations may differ or only a limited number of functions can be controlled.

See "Interface Functions According to the System Configuration" on page 7-19.

Preparations

On the DFS-500/500P

- It is recommended to supply the signal (reference sync signal) output from the BLACK BURST OUT connector on the DFS-500/500P to the VTRs and the editing control unit to improve editing accuracy
- Turn the power off, and set the controller select switch on the SY-172 board in the processor unit to BVE-900. Then turn the power on again.

On the recorder VTR

Set the PB, PB/EE selector to PB.

On the BVE-900/910

Set the PVW mode to EE.

- **BVE-900 with no BKE-900K installed:** Set BYTE-1 of the MAIN BLOCK INTERFACE parameter in the SYSTEM SETUP mode to H"01" (EE).
- **BVE-910 or BVE-900 with the BKE-900K installed:** Set PVW MODE of the SW'ER CONFIGURATION parameter in SYSTEM SETUP mode to EE.

Notes on operation

- The DFS-500/500P has a built-in frame synchronizer. So the actual editing point delays one frame against the edit point of the player VTR set on the BVE-900/910. The edit point on the recorder does not delay.
Example: If the In point of the player VTR is set to 00:00:10:10, recording begins from 00:00:10:09.
- To execute an effect in the reverse direction with the BVE-900/910, add 3000 to the pattern number of the DFS-500/500P.
Example: To execute effect No. 25 in the reverse direction, set 3025.
Example: To execute effect No. 1300 in the reverse direction, set 4300.
As for a user-program effect, add 500 to the pattern number.
Example: To execute effect No. 9203 in the reverse direction, set 9703.
- Effects whose transitions continue as shown in figure (1) cannot be executed. Be sure to keep an interval of 10 frames or more between transitions as shown in figure (2).

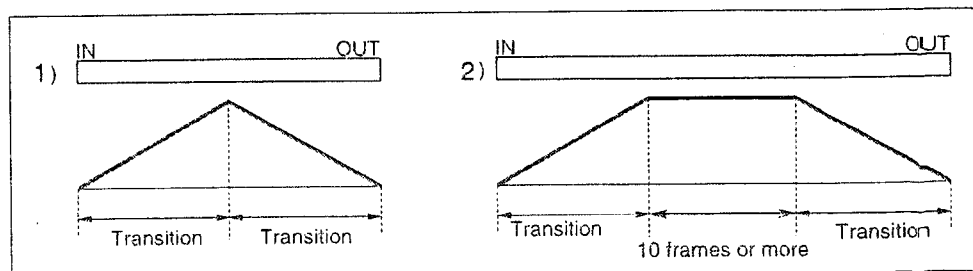

Setting the minimum duration of the transition

Control from the BVS-3000 Series

When the BVS-3000 series video switcher is added to the editing system using the BVE-900 series and DFS-500/500P, the DFS-500/500P functions as an effect generator, and the BVS-3000 as a switcher, which allows construction of an effective editing system.

See "Connections with the BVS-3000" on page 3-10.

Functions of the DFS-500/500P controlled from the BVE-900/910

- Selecting a foreground picture
- Designating an effect pattern number
- Selecting the direction of the transition (NORM/REV)
- Setting the duration of the transition
- Executing the automatic transition (AUTO TRANS)
- Setting the pattern size
- Storing and recalling a snap shot (LEARN/RECALL)
- Saving and loading user program data and snap shot data (SAVE/LOAD)

Functions of the DFS-500/500P controlled from the BVS-3000

- Selecting a foreground picture (KEY-1 bus)
- Designating an effect pattern number
- Selecting the direction of the transition (NORM/REV)
- Setting the duration of the transition
- Executing automatic transition (AUTO TRANS)
- Executing transition with the fader lever
- Setting the pattern size
- Turning on and off the title mode
- Storing and recalling a snap shot (LEARN/RECALL)
- Selecting a background picture for a flip/tumble effect

The BVS-3000 used in the system should be provided with ROM version V3.01 or higher.

Note

The BVE-900 with the BKE-900K editor expansion is used in the same way as the BVE-910. However when the BKE-900K is not installed, some operations may differ or only a limited number of functions can be controlled.

See "Interface Functions According to the System Configuration" on page 7-19.



Preparations

On the DFS-500/500P

Turn the power off, and set the controller select switch on the SY-172 board in the processor unit to BVS-3000. Then turn the power on again.

On the BVE-900/910

Set DATA-5 (ACTIVE BANK) in BLOCK-1 (SW'ER) of GROUP-5 (SW'ER/MIXER) to ME1 + ME3 in SYSTEM SETUP mode. (The standard setting is ME 1.)

To adjust the horizontal and subcarrier phases of the program-output signal of the DFS-500/500P

- 1 Adjust the horizontal and subcarrier phases of the primary video signals of the BVS-3000.
- 2 Press the KEY-1 BUS button on the BVS-3000 to select a color-bar signal.
- 3 Select the effect pattern of number 1056 on the DFS-500/500P, and press the AUTO TRANS button. Then the color-bar signals appear on the program monitor screen.
- 4 Set the transition mode of the BVS-3000 to KEY-1.
- 5 Execute the wipe of number 3 on the BVS-3000, then both the color-bar signal and key signal of the DFS-500/500P appear on the monitor screen, dividing the screen at the center.
- 6 Adjust the position (horizontal phase) and hue (subcarrier phase, if a component signal is used, this adjustment is unnecessary) of both the color-bar signals with the SYNC GEN LOCK switches and VRs on the DA-63 board of the DFS-500/500P.

To adjust the phase of the key signal output from the DFS-500/500P

Adjust the phase while monitoring the picture displayed on the program monitor screen connected to the BVS-3000.

- 1 Select the effect pattern of number 1100 on the DFS-500/500P, and execute the effect with the fader lever until the picture appears on the half of the screen.
- 2 Press the BORDER button on the DFS-500/500P, and the border is added to the effect pattern. Set the width of the border to the minimum.
- 3 Adjust the width of the left and right borders of the effect pattern of number 1100 with the KEY OUT DELAY switch on the DA-63 board of the DFS-500/500P to equal width.

Control from the BVE-3000 Series

To adjust the level of the key-fill signal of the DFS-500

- 1 Select the color-bar signal with the KEY-1 BUS button on the BVS-3000.
- 2 Select the effect pattern of number 1056 on the DFS-500/500P, and press the AUTO TRANS button. The color bar signal appears on the program monitor screen.
- 3 Execute the wipe of number 3 on the BVS-3000 so that the color bar-signal and key signal of the DFS-500/500P appear on the monitor screen dividing the screen at the center.
- 4 Adjust the video signal level for each picture with the GAIN VRs on the DA-63 board in the DFS-500/500P.

Basic operation

To execute the effect of the DFS-500/500P

A background picture corresponds to the From picture and a foreground picture the To picture.

For effect patterns of number 0 through 299, use the patterns of the BVS-3000.

For effect patterns of number 300 and after, use the patterns of the DFS-500/500P.

(If all the switches of the S1-2 on the IFB-3 board of the BKE-913 are set to ON, patterns of number 0 through 299 of the DFS-500/500P can be used. The normal setting for these switches is OFF.)

To control from the BVE-900/910 (setting on the screen of the BVE-900/910)

- 1 Select WIPE as effect type.
- 2 Set the parameters FROM, TO, and TRANSITION.
- 3 Designate a pattern number of the DFS-500/500P as the wipe number.
- 4 Set the edit points on the recorder VTR, player VTR 1 and player VTR 2.
- 5 Press the PREVIEW or REC button.

The effect of the DFS-500/500P designated in step 3 is executed.

To control from the BVS-3000 (setting on the control panel of the BVS-3000)

- 1 Select a background picture on the PGM bus.
- 2 Select a foreground picture on the KEY-1 bus.
- 3 Select DME as the transition type.
- 4 Designate a pattern number of the DFS-500/500P on AUX-1 of wipe.
- 5 Move the fader lever, or press the AUTO TRANS button.

The effect of the DFS-500/500P designated in step 4 is executed.

- To execute the effect of the DFS-500/500P from the BVE-900/910 or BVS-3000, the parameters for the effect should be set on the DFS-500/500P.
- The BVS-3000 cannot control the EDGE, LOCATION, and MATTES/BKGD sections on the DFS-500/500P.

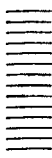

Notes on operation

- To execute an effect in the reverse direction with the BVE-900/910, add 3000 to the pattern number of the DFS-500/500P.

Example: To execute effect No. 25 in the reverse direction, set 3025.

Example: To execute effect No. 1300 in the reverse direction, set 4300.

As for a user-program effect, add 500 to the pattern number.

Example: To execute effect No. 9203 in the reverse direction, set 9703.

To control from the BVS-3000, press the REVERSE button on the control panel of the BVS-3000.

- Effects whose transitions continue as shown in figure (1) cannot be executed. Be sure to keep an interval of 10 frames or more between transitions as shown in figure (2).

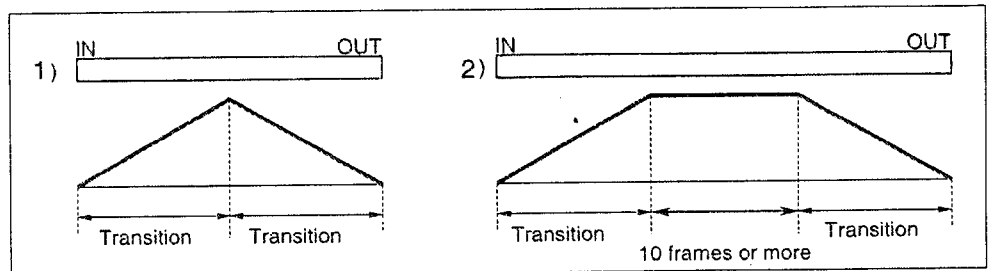

Minimum transition period

- When PVW mode is set to FULL, be careful of the following points.
 - (1) Set the Out point of a foreground picture 10 frames or more after the end of transition.

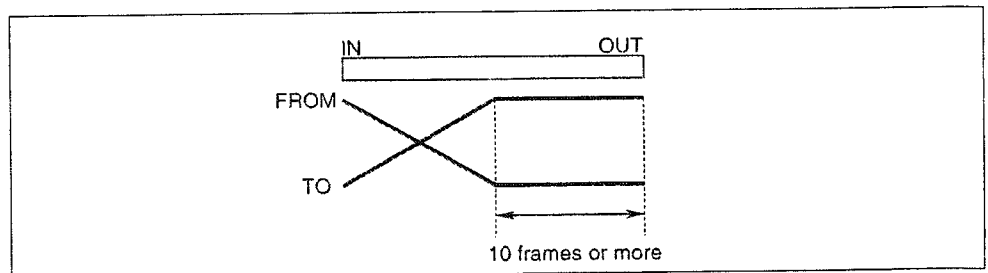

OUT point of a foreground picture

- (2) When the duration of the transition of a background picture is set to 0 (the effect instantaneously begins at the In point), the effect may begin two frames after the In point in preview. When recording, it is executed correctly according to the setting.

Control from the BVE-3000 Series

- The number for the snap shot registers differ between the BVS-3000 and DFS-500/500P. Be careful of the following points when specifying a register number. The BVS-3000 has 10 E-FILE registers from 0 to 9, and the DFS-500/500P has 100 snap shot registers from 0 to 99. If a register number of 9 or above is selected with the BVE-900/910, the corresponding register is selected on the DFS-500/500P, and register 9 is selected on the BVS-3000. If a number 0 through 8 is selected, the corresponding register is selected according to the setting on the control panel of the BVS-3000.



Interface Functions According to the System Configuration

Interface functions according to the system configuration

Functions	System configuration	
	BVE-900/910 and DFS-500/500P	BVE-900/910, BVS-3000 and DFS-500/500P
Cut	Controllable	Controllable (on the BVS-3000)
Dissolve	Controllable	Controllable (on the BVS-3000)
Wipe (including DME patterns)	Controllable	Controllable 0 to 299: Patterns on the BVS-3000 ^{a)} 300 and above: Patterns on the DFS-500/500P
Key wipe	Controllable (same as wipe)	
Pattern key	Not controllable (same as wipe, no size setting)	
Key mix	Controllable (same as mix)	Controllable (on the BVS-3000)
Key fade	Not controllable	Controllable (on the BVS-3000)
Downstream key	Controllable (9-pin or GPI)	Controllable (DSK on the BVS-3000, not on the DFS-500/500P)
User-program effect ^{b)}	Controllable	Controllable
Save and load of INIT PANEL (snap shot)	Controllable with the BVE-910 or the BVE-900 with the BKE-900K installed	Controllable with the BVE-910 or the BVE-900 with the BKE-900K installed
Save and load of a user-program effect to and from the EDL	Controllable with the BVE-910 or the BVE-900 with the BKE-900K installed	Controllable with the BVE-910 or the BVE-900 with the BKE-900K installed
Dump and load of snap shot data and user-program effect data to and from the FDD	Controllable with the BVE-910 or the BVE-900 with the BKE-900K installed	Controllable with the BVE-910 or the BVE-900 with the BKE-900K installed
Usable PVW mode: EE	Controllable	Controllable
Usable PVW mode: MON	Controllable	Controllable
Usable PVW mode: FULL	Not controllable	Controllable

a) If the S1-2 switches on the IFB-3 board of the BKE-913 are set to ON, all patterns can be selected on the DFS-500/500P.

b) Designate pattern number 9xxx for wipe and key wipe.

Appendixes

Specifications	A-2
Recommended Equipment and Cables	A-4
Glossary	A-5
Types of Effects	A-7
Adjustable Parameters	A-8
Effects Classified by Type of Motion	A-10
Parameters for Modifying Effect Patterns	A-11
Effect Pattern Image List	A-14

Specifications

Appendixes

General

Signal system	DFS-500: NTSC system DFS-500P: PAL system
Power requirements	DFS-500: 100/120 V AC, 50/60 Hz DFS-500P: 220/240 V AC, 50/60 Hz
Operating voltage	DFS-500: 90 to 132 V AC, 48 Hz to 63 Hz DFS-500P: 180 to 264 V AC, 48 to 63 Hz
Power consumption	140 W
Operating temperature	0°C to 40°C (32°F to 104°F)
Dimensions	Control panel: 424 × 116 × 344 mm (w/h/d) (16 ³ / ₄ × 4 ⁵ / ₈ × 13 ⁵ / ₈ inches) Processor unit: 424 × 177 × 450 mm (w/h/d) (16 ³ / ₄ × 7 × 17 ³ / ₄ inches)
Mass	Control panel: 3 kg (6 lb 10 oz) Processor unit: 17 kg (37 lb 8 oz)

Input signals

VIDEO INPUTS 1 through 4

COMPOSITE	BNC type (1 in each) VIDEO: 1.0 V _{p-p} , 75 ohms SYNC: 0.286 V _{p-p} (NTSC) or 0.3 V _{p-p} (PAL) BURST: 0.286 V _{p-p} (NTSC) or 0.3 V _{p-p} (PAL)
Y/C	4-pin (1 in each) Y: 1.0 V _{p-p} , 75 ohms C: 0.286 V _{p-p} (NTSC) or 0.3 V _{p-p} (PAL), 75 ohms, burst SYNC: 0.286 V _{p-p} (NTSC) or 0.3 V _{p-p} (PAL)
COMPONENT (Betacam)	12-pin (1 in each) Y: 1.0 V _{p-p} , 75 ohms R-Y/B-Y: 0.7 V _{p-p} (NTSC) or 0.525 V _{p-p} (PAL), 75 ohms, 100/7.5/77/7.5 (NTSC) or 100/0/75/0 (PAL) color bar

DSK VIDEO IN

COMPOSITE/G/Y	BNC type (1, with a loop through output) COMPOSITE VIDEO: 1.0 V _{p-p} , 75 ohms SYNC: 0.286 V _{p-p} (NTSC) or 0.3 V _{p-p} (PAL) BURST: 0.286 V _{p-p} (NTSC) or 0.3 V _{p-p} (PAL) Y: 1.0 V _{p-p} , 75 ohms G: 0.7 V _{p-p} , 75 ohms
B/B-Y	BNC type (1) B-Y: 0.7 V _{p-p} (NTSC) or 0.525 V _{p-p} (PAL), 75 ohms, 100/7.5/77/7.5 (NTSC) or 100/0/75/0 (PAL) color bar B: 0.7 V _{p-p} , 75 ohms
R/R-Y	BNC type (1) R-Y: 0.7 V _{p-p} (NTSC) or 0.525 V _{p-p} (PAL), 75 ohms, 100/7.5/77/7.5 (NTSC) or 100/0/75/0 (PAL) color bar R: 0.7 V _{p-p} , 75 ohms

EXT KEY IN	BNC type (1) 1.0 Vp-p, 75-ohms
DSK KEY IN	BNC type (1, with a loop-through output) 1.0 Vp-p, 75-ohms
GEN LOCK IN	BNC type (1, with a loop-through output) SYNC: 0.286 Vp-p (NTSC) or 0.3 Vp-p (PAL) BURST: 0.286 Vp-p (NTSC) or 0.3 Vp-p (PAL)

Output signals

PGM OUT 1, 2	
COMPOSITE	BNC type (1 in each) VIDEO: 1.0 Vp-p, 75 ohms SYNC: 0.286 Vp-p (NTSC) or 0.3 Vp-p (PAL) BURST: 0.286 Vp-p (NTSC) or 0.3 Vp-p (PAL)
Y/C	4-pin (1 in each) Y: 1.0 Vp-p, 75 ohms C: 0.286 Vp-p (NTSC) or 0.3 Vp-p (PAL), 75 ohms, burst SYNC: 0.286 Vp-p (NTSC) or 0.3 Vp-p (PAL)
COMPONENT (Betacam)	12-pin (1 in each) Y: 1.0 Vp-p, 75 ohms R-Y/B-Y: 0.7 Vp-p (NTSC) or 0.525 Vp-p (PAL), 75 ohms, 100/7.5/77/7.5 (NTSC) or 100/0/75/0 (PAL) color bar
KEY OUT	BNC type (1) 1.0 Vp-p (without sync), 75-ohms
BLACK BURST OUT	BNC type (4) SYNC: 0.286 Vp-p (NTSC) or 0.3 Vp-p (PAL), 75 ohms BURST: 0.286 Vp-p (NTSC) or 0.3 Vp-p (PAL), 75 ohms

Control signals

EDITOR	9-pin remote
T1/CUE, T2	BNC-type (1 in each), TTL level
CONTROL PANE	25-pin remote

Specifications

Electric characteristics

Sampling rate	Y: 910 fH (fH: 15.734 kHz) (NTSC) or 908 fH (fH: 15.625 kHz) (PAL) R-Y/B-Y: $\frac{1}{4} \times 910$ fH (NTSC) or $\frac{1}{4} \times 908$ fH (PAL)
Quantalization	Y/R-Y/B-Y: 8 bits
Linearity (composite output)	DP: Less than 2.5° (composite input) Less than 1.0° (Y/C, component input) DG: Less than 3.5% (composite input) Less than 2.0% (Y/C, component input)
Crosstalk	Less than -50 dB
Frequency response	0 to 5 MHz +0.5 dB/-1 dB
S/N	More than 51 dB (COMPOSITE) More than 55 dB (Y/C, COMPONENT)
Y/C delay	Less than 50 ns (COMPOSITE) Less than 20 ns (COMPONENT)

Supplied accessories

- AC power cord (1)
- 25-pin control cable, 10 m (1)
- Label (1 set)
- Operation manual (1)

Design and specifications subject to change without notice.

Recommended Equipment and Cables

- Editing control unit: RM-450, BVE-600, BVE-900, BVE-910
- Video switcher: BVS-3000 series
- VTR: VO series, BVU series, EVO series, PVW series
- Audio mixer: MXP-290, VSP-A600
- Connecting cable: 9-pin remote control cable RCC-5G/10G/30G,
33-pin remote control cable RCC-5F

Glossary

A-roll editing

A basic editing using a recorder VTR and a player VTR.

A/B-roll editing

An editing using a recorder VTR and two player VTRs. The effects are added to the pictures of the two player VTRs, and the picture with the effect is recorded on the recorder VTR. Using an editing control unit with the three VTRs enables highly accurate editing.

Background picture

A picture to which a foreground picture (effect pattern) is inserted or which disappears from the screen after the effect. It is specified as the From picture. It is selected in the background bus.

Bus

A signal path to use the input signals or color-matte signals for a specific purpose. A signal in the bus is passed to the next process.

B-Y signal

A color-difference signal. The blue signal minus Y signal.

Color bar signal

A test signal displayed on the screen as vertical stripes of different colors. It is used to check hue and saturation of a video camera or a video monitor.

Color matte

A color signal generated by the built-in color-matte generator. The hue, saturation and luminance of the color matte can be adjusted.

Component signal

A video signal whose luminance (Y) and color-difference (R-Y, B-Y) signals are separated.

Composite video signal

A signal containing video, color-burst and sync signals.

Crosspoint

An electronic switch where video or audio signal lines cross. Multiple input lines and one or more output signal lines cross. When the switch is closed, usually by pressing a button, the signal passes.

Cut

An instantaneous switch from one picture to another, or an instantaneous insertion or deletion of a key signal.

Downstream key

A key inserted as characters or figures on a program picture composed of a background picture and a foreground picture. The transition of a background picture and a foreground picture is possible behind the downstream key. Inserting a downstream key requires a key-source signal to cut the background picture and a key-fill signal to fill the hole.

Dissolve

An effect wherein a picture gradually fades out as the next picture gradually fades in.

Editing control unit

A video editor which remotely controls a video tape recorder, video switcher, audio switcher, etc. for video tape editing.

Field

See "Frame."

Foreground picture

A picture to fill as effect pattern which is inserted on to a background picture, or which appears after the effect. It is specified as a To picture. It is selected in the foreground bus.

Frame

In an NTSC color television system, a frame consists of 525 scanning lines, which is double the number of 252.5 horizontal scanning lines comprising a field. The first scanning is called an odd field, and the second one is called an even field. A frame is composed of two fields, odd field and even field.

GPI (General-Purpose Interface)

An interface to control an editing control unit which is not equipped with a defined interface.

Key clip

To specify the reference level of a luminance signal to use a key-source signal for key insertion. The part of the signal higher than this level is filled with the key-fill signal and inserted in the background picture.

Glossary

Key fill

A signal to fill the hole cut with the key-source signal.

Key frame

A set of data to specify the status of a picture which changes as time passes at every moment. An effect can be created as desired by making up multiple key frames in the order of time passing.

Key invert

To reverse the polarity of a key-source signal so that the key-fill signal fills the dark part of the key-source signal.

Key mask

To mask a part of a title key or downstream key signal to show the desired part only. It may be called key crop.

Key source

A signal to cut a part in the background picture for a title key or a downstream key.

Luminance signal

Also called Y signal, contains the brightness information for a video signal.

Mask

See "Key mask."

Mix

An effect where a signal fades in while another signal fades out.

Postroll

To run tapes after the Out point for a specific period of time to check the picture that follows.

Preroll

To run a tape with a specific period of time before the edit In point to obtain stable running of a tape and to synchronize the timing with other VTRs.

R-Y signal

A color-difference signal. The red signal minus Y signal.

Snap shot

Function to store various electronic settings as a set of data, and recall it. The data may be called a snap shot.

Subcarrier (SC)

A signal that contains color information of a video signal. The amplitude represents the saturation, and the relative phase against the color burst signal represents the hue. It is also called color subcarrier.

Superimpose

To put characters or figures on a picture so that both can be seen at the same time.

S-video input and output connector

A connector which inputs and outputs a video signal which is separated into the luminance signal (Y) and chrominance signal (C). The S-video signal assures a high-resolution picture because interference between the luminance and chrominance signals can be avoided.

Title key

Function to cut a part of a background picture and to superimpose characters or figures there. Inserting a title key requires a key-source signal to cut the background picture and a key-fill signal to fill the hole.

Transition

The period during which one picture changes to another. The period to insert or remove the effect pattern or key is also called transition.

Wipe

A transition where a picture replaces another in the shape of a selected pattern from the left, right, top or bottom of the screen. Various patterns such as wiping diagonally, from the center, with a circle, etc. are available. A picture insertion is also possible by pausing the wipe operation.

Types of Effects

The effects of the DFS-500/500P are classified into the following types, and multiple patterns are available for each type.

Effect pattern number 1000 and after mean digital multi effects (DME) and the number 9000s mean user-program effects.

Types of effect

Pattern No.	Types of effects	Quantity	Page No. to be referred
1 to 324	Wipe (single wipe pattern)	33	A-14
700 to 809	Matrix wipe	37	A-15
1000 to 1016	Mosaic	8	A-16
1020 to 1026	Still mirror	6	A-16
1030 to 1056	Y&C modify	8	A-16
1059	Cut	1	A-17
1060 to 1067	Freeze, strobe, cinema	5	A-17
1080	Mix	1	A-17
1100 to 1109	Picture-in-picture	10	A-17
1130 to 1131	Zoom up	2	A-17
1140 to 1151	Active lighting, spotlighting	7	A-17
1200 to 1204	Dynamic mirror	3	A-18
1210 to 1213	Stream	4	A-18
1231 to 1233	Accordion	2	A-18
1240 to 1241	Multi-screen	2	A-18
1250 to 1270	Wave modulation	12	A-18
1300 to 1307	Slide	8	A-19
1330 to 1383	Split slide	21	A-19
1403 to 1451	Multi-split	6	A-20
1500 to 1522	Compression	12	A-20
1603 to 1612	Two-dimensional rotation	4	A-20
1620 to 1644	Two-dimensional rotation + Compression + Slide	6	A-21
1690	Two-dimensional rotation + Compression + Slide (modified)	1	A-21
1700 to 1707	Three-dimensional rotation	8	A-21
1730 to 1742	Door	6	A-21
1760 to 1765	Three-dimensional rotation + Compression	3	A-22
1770 to 1816	Three-dimensional rotation + Compression + Slide	16	A-22
1900 to 1964	Flip, tumble	33	A-23, 24
2000 to 2006	Twist	4	A-24
2100 to 2144	Page turn	40	A-25, 26
2150 to 2154	Page turn (modified)	5	A-26
2200 to 2213	Sphere	9	A-26
2250 to 2251	Picture-in-picture sphere	2	A-26
9000 to 9009	Linear-type user program (transition)	10	—
9100 to 9109	Linear-type user program (animation)	10	—
9200 to 9209	Non-linear-type user program (transition)	10	—
9300 to 9309	Non-linear-type user program (animation)	10	—
Total		365	

Adjustable Parameters

The following functions can be added to each effect pattern

Adjustable parameters

Pattern No.	Parameters (Function)														
	EDGE		LOCATION			EFFECT CONTROL				LIGHTING			TRAIL/SHADOW		
	B	S	X	Y	Z	F1	F2	F3	F4	S	L	P	T	B	S
1 to 23 24, 26 30 to 324 700 to 809	A	A	N	N	N	N	N	N	N	N	N	N	N	N	N
1000 to 1006 1010 to 1011 1015 to 1016	N	N	N	N	N	N	N	N	N	N	N	N	A	A	A
1020 to 1026 1030 to 1033 1040 to 1046 1050 1055 to 1056 1059	N	N	N	N	N	N	N	N	N	N	N	N	A	A	A
1060 to 1061 1065 1066 to 1067 1080	A	N	N	N	N	N	N	N	N	N	N	N	A	A	A
1100 to 1101 1102 to 1109 1130 to 1131 1140 1141 to 1144 1150 to 1151	A	N	A	A	N	N	N	N	N	N	N	N	A	A	A
1200 to 1204 1210 to 1213 1231, 1233 1240 to 1241 1250 to 1251 1252 to 1253 1260 to 1265 1266 1270	A	N	N	N	N	N	N	N	N	N	N	N	A	A	A
1300 to 1349 1350 to 1351 1360 to 1373 1380 to 1383	A	N	N	N	N	N	N	N	N	N	N	N	A	A	A
1403 to 1451 1500 to 1522	N	N	N	N	N	N	N	N	N	N	N	N	A	A	A
1603 to 1644 1690	A	N	N	N	N	N	N	N	N	N	N	N	A	A	A
1700 to 1770 1780 to 1783	A	N	N	N	N	N	N	N	N	A	A	A	A	A	A

Introductory

A: Adjustable

N: Not adjustable

[EDGE] B: Border, S: Soft-edge

[LIGHTING] S: Spotighting, L: Line lighting, P: Plane lighting

[TRAIL & SHADOW] T: Trail, B: Drop border, S: Shadow

[EFFECT CONTROL] F1, F2, F3, F4: See pages A-11, 12, 13 for details on the parameters.

Adjustable parameters

Pattern No.	Parameters (Functions)														
	EDGE		LOCATION			EFFECT CONTROL				LIGHTING			TRAIL/ SHADOW		
	B	S	X	Y	Z	F1	F2	F3	F4	S	L	P	T	B	S
1800 to 1806	A	N	N	N	N	N	N	N	N	A	A	A	A	A	A
1807 to 1811	A	N	N	N	N	N	N	N	N	A	N	A	A	A	A
1812 to 1816	A	N	N	N	N	N	N	N	N	A	A	A	A	A	A
1900 to 1901	A	N	N	N	N	N	N	N	N	N	N	N	A	A	A
1902 to 1945	A	N	N	N	N	N	N	N	N	A	A	A	A	A	A
1946	A	N	N	N	N	N	N	N	N	A	N	A	A	A	A
1947	A	N	N	N	N	N	N	N	N	N	N	N	A	A	A
1948	A	N	N	N	N	N	N	N	N	A	N	A	A	A	A
1949 to 1950	A	N	N	N	N	N	N	N	N	A	A	A	A	A	A
1951 to 1954	A	N	N	N	N	N	N	N	N	N	N	N	A	A	A
1955	A	N	N	N	N	N	N	N	N	A	A	A	A	A	A
1956 to 1959	A	N	N	N	N	N	N	N	N	N	N	N	A	A	A
1960 to 1964	A	N	N	N	N	N	N	N	N	A	A	A	A	A	A
2000 to 2006	A	N	N	N	N	N	N	N	N	A	A	N	A	A	A
2100 to 2144	A	N	N	N	N	N	N	N	N	N	A	N	A	A	A
2150 to 2154	A	N	N	N	N	A	A	N	N	N	A	N	A	A	A
2200 to 2213	A	N	N	N	N	N	N	N	N	A	N	N	A	A	A
2250 to 2251	A	N	A	A	A	A	A	A	A	A	N	N	A	A	A
9000 to 9109	A	N	N	N	N	A	N	N	N	N	N	N	A	A	A
9200 to 9309	A	N	N	N	N	A	N	N	N	N	A	N	A	A	A

Appendixes

Effects Classified by Type of Motion

The effect patterns of the DFS-500/500P can be classified into the following two types according to the direction of the motion and the adjustable parameters.

Effects classified by type of motion

Motion type	Pattern No.
<p>Transition type: A picture moves in one direction independent of the direction of the fader lever. The crosspoint selected on the BACKGROUND bus and the FOREGROUND bus is changed when the effect is executed.</p>	<p>1 to 1000 1003 to 1010 1059 1080 1200 to 1233 1260 to 2213 9000 to 9009 9200 to 9209</p>
<p>Animation type: A effect pattern moves in back-and-forth motion. The crosspoint selected on the BACKGROUND bus and the FOREGROUND bus is not changed when an effect is executed. During effect execution, the NORM/REV indicator lights when the controller select switch is set to the position other than BVE-600/RM-450.</p>	<p>1001 1011 to 1056 1060 to 1067 1100 to 1151 1240 to 1253 2250, 2251 9100 to 9109 9300 to 9309</p>

Parameters for Modifying Effect Patterns

The following parameters for user-modified effects can be adjusted with the pattern-setting controls in the EFFECT CONTROL section.

Parameters for modifying effect patterns

Pattern No.	Outline of the effect pattern or parameter		
	Control	Adjustable Item	Adjustable range Min.: turning the control fully counterclockwise Max.: Turning the control fully clockwise

1010 1011	User mosaic		
	F1	Maximum size of a mosaic cell	(Continuous change)
	F2	Aspect ratio of a mosaic cell	Min.: Wider Center: Square Max.: Higher
	F3	Softness (flicker)	Min.: Off, Max.: Theoretical value (Reciprocal of LPF for the numbers of pixels)
1015 1016	Variable mosaic		
	F1	Maximum size of a mosaic cell	1, 2, 4, 8, ...
	F2	Aspect ratio of a mosaic cell	Min.: Wider Center: Square Max.: Higher
	F3	Softness (flicker)	Min.: Off Max.: Theoretical value (Reciprocal of LPF for the numbers of pixels)
	F4	Aspect ratio of the mosaic area	Min.: Wider Max.: Higher
1040 1043 1046	Bit mask (solarization, posterization) The less significant bits of the luminance and color-difference data for a foreground picture are cut with round up above five and down under four. 1040: a luminance signal and a color-difference signal, 1043: a luminance signal, and 1046: a color-difference signal. A processed picture and a background picture can be mixed using the fader lever.		
	F1	Degree of bit masking	1, 2, 3, ...
1050	Modify A processed picture and a background picture can be mixed using the fader lever.		
	F1	Degree of bit masking	1, 2, 3, ...
	F2	Selecting a positive picture or a negative picture	Color positive, color negative, monochrome, monochrome negative
	F3	Degree of soft luminance	Min.: Off

(continued)

Modifying Parameters

Parameters for modifying effect patterns

1055 1056	Modifying pattern		
	F1	Degree of bit masking	1, 2, 3, ...
	F2	Selecting a positive picture or a negative picture	Color positive, color negative, monochrome, monochrome negative
	F3	Degree of soft luminance	Min.: Off
	F4	Aspect ratio of the area to be processed	Min.: Wider Max.: Higher
1065	Strobe (Number of displayed frames is reduced with the intermittent field freeze.)		
	F1	Number of displayed frames per second	Min.: 30 Max.: 0 (still)
1066 1067	Cinema		
	F1	Number of displayed frames per second	Min.: 30 Max.: 0 (still)
	F2	Degree of a wide screen (screen width)	Min.: Full screen Max.: about 1/3
	F3	Displayed position of a wide screen	Min.: Center (default setting) to Max.: from top to bottom
	F4	Degree of soft-luminance	Min.: Off
1102 1106 1108 1103 1107 1109	Three-dimensional picture-in-picture 1102 1106 1108: Dissolve using the fader lever 1103 1107 1109: Initializing all the parameters using the fader lever		
	F1	X-axis rotation	Min.: 0 (default) to max.: -70° to +70°
	F2	Y-axis rotation	Min.: 0 (default) to max.: -70° to +70°
	F3	Z-axis rotation	Min.: 0 (default) to max.: -70° to +70°
	F4	Perspective	Min.: Small Max.: Large
1104 1105	Skewed a picture-in-picture 1104: Dissolve with the fader 1105: Initializing all the parameters with the fader lever		
	F1	Expansion and reduction along the X-axis	Min.: x1 (default) to max.: 1/8 to 3 times
	F2	Expansion and reduction along the Y-axis	Min.: x1 (default) to max.: 1/8 to 3 times
	F3	Degree of distortion along the X-axis	Min.: No distortion (default)
	F4	Degree of distortion along the Y-axis	Min.: No distortion (default)
1150 1151	Spotlighting		
	F1	Maximum brightness corresponding to the upper end position of the fader lever	
	F4	Aspect ratio of the area to be processed by spotlighting	Min.: Wider Max.: Higher

Parameters for modifying effect patterns

1250 1251 1252 1253 1270	Ripple (1250), flag (1251), ripple glass (1252), ground glass (1253), ripple wipe (1270) Amount of modification		
	F1	Amount of modification 1 (1250: Modification along Y axis)	Min.: 0 (no modification)
	F2	Amount of modification 2 (1250: Modification along X axis, 1251: Direction of modification, 1252 1253 1270: Not used)	Min.: 0 (no modification)
	F3	Cycle of modification	Min.: Long cycle (coarse) Max.: Short cycle (fine)
	F4	Speed of movement	Min.: 0 (still with modification) Max.: High speed
1380 1381 1382 1383	Slide parameter		
	F1	Width of slide	Min.: maximum width Max.: minimum width
	F2	Direction of sliding	One rotation from minimum to maximum
	F3	Z-axis rotation	Min.: 0 (default) to max.: -1 to +1 rotation
1690	Two-dimensional spiral		
	F1	Amount of curving	Min.: 0 (straight line) Max.: Maximum curve
	F2	Direction of curving	One rotation from the minimum to the maximum
	F3	Amount of spiral	Min.: 0 (default) to max.: -2 to +2 rotations
	F4	Z-axis rotation	Min.: 0 (default) to max.: -8 to +8 rotations
2150 2151 2152 2153 2154	Page turn		
	F1	Direction of turning	1.5 turns from minimum to maximum
	F2	Modified amount of direction of turning	Min.: 0 (default) to max.: -1 to +1 turn
2250 2251	Spherical picture-in-picture		
	F1	Degree of modification	Min.: 0 (plane) Max.: Sphere
	F2	Z-axis rotation	Min.: 0 Max.: +1 rotation
	F3	Mapping area along X-axis	Min.: Maximum area Max.: Minimum area
	F4	Mapping area along Y-axis	Min.: Maximum area Max.: Minimum area

Effect Pattern Image List

Appendixes

How to read the pattern

Direction of the effect¹⁾

Left and right mirror picture

Upper and lower mirror pictures

1) Direction of the effect
The pattern shown is for when the effect is executed in the normal direction.

Abbreviation in the illustrated patterns
 FG: Foreground picture
 BG: Background picture
 T: Transition type
 A: Animation type

Wipe (single pattern wipe)									
1		2		3		4		5	
6		7		8		9		10	
11		12		17		18		19	
20		21		22		23		24	
26		30		31		32		33	
310		311		312		313		320	
321		323		324					

Matrix wipe									
700		702		707		710		712	
717		740		742		750		752	
754		760		761		762		763	
764		770				771			
772				773					
774									
787		788		789		790		791	
792		793		794		795		796	
797		798		799				800	
808		809							

Effect Pattern Image List

Appendixes

Mosaic							
1000					1001		
T				A			
1003					1006		
T				T			
1010					1011		
T				A			
1015				1016			
A				A			

Still mirror							
1020				1021			
A				A			
1022				1023			
A				A			
1024				1026			
A				A			



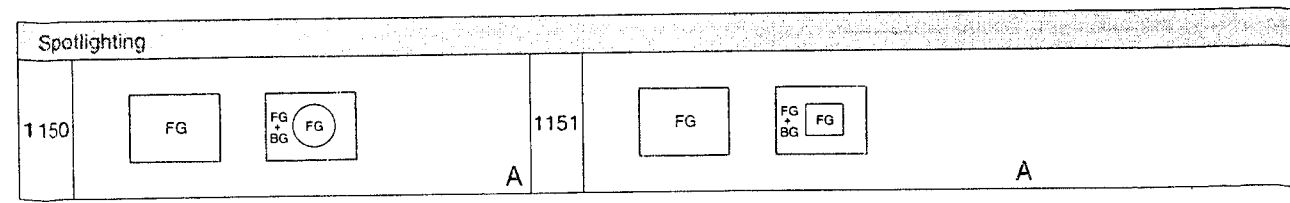
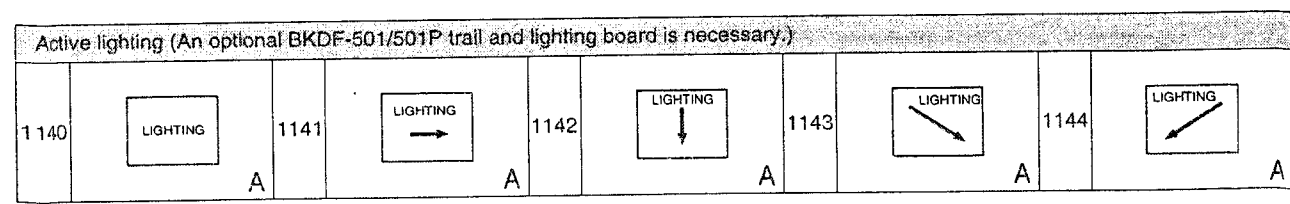
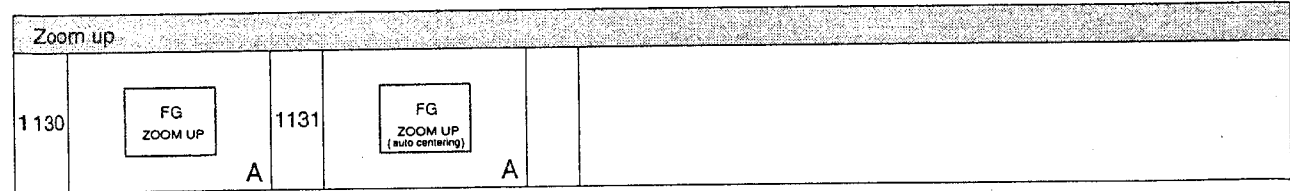
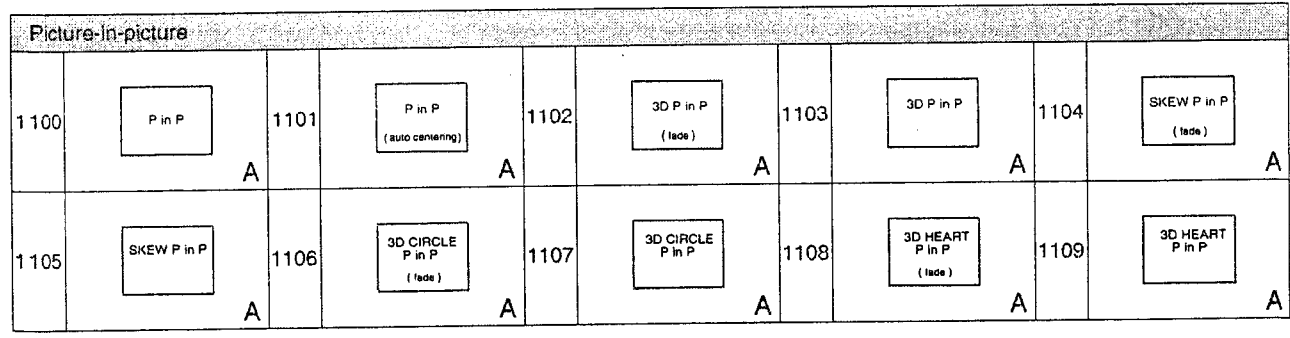
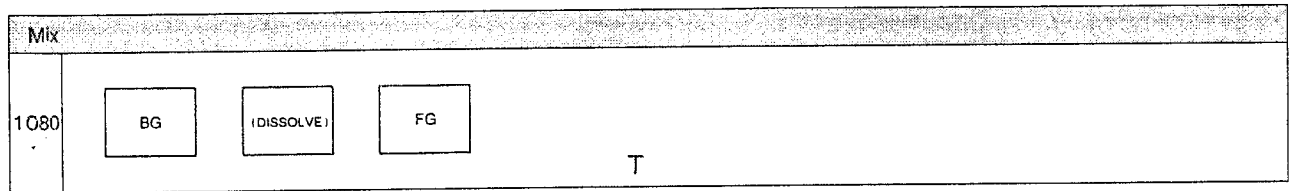
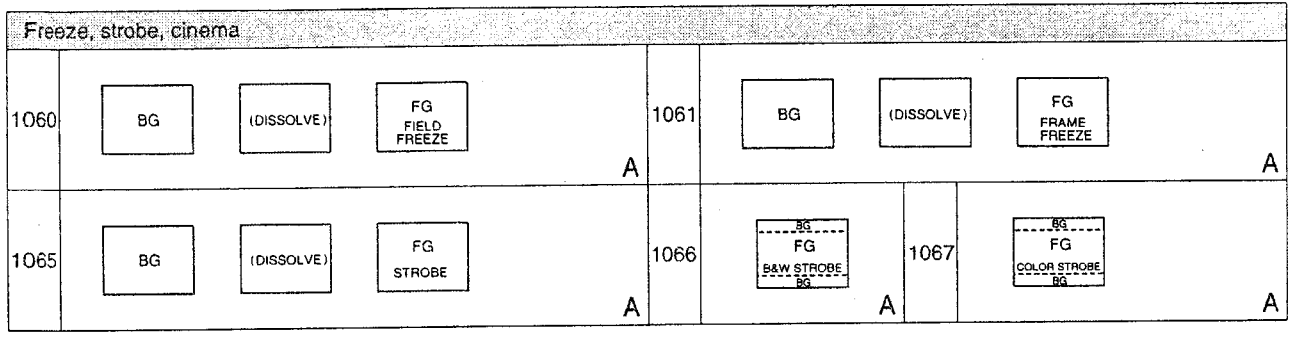
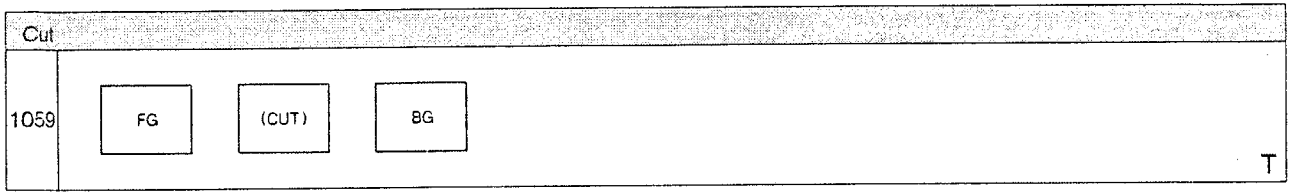





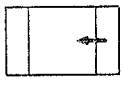
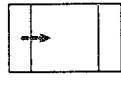
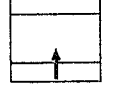
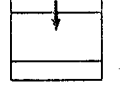
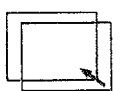
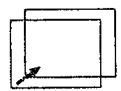
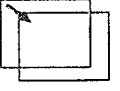
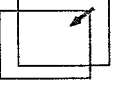

Y&C modify							
1030				1033			
A				A			
1040				1043			
A				A			
1046				1050			
A				A			
1055				1056			
A				A			

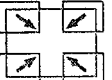
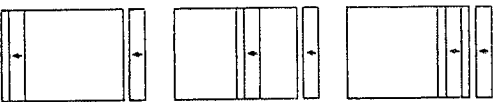
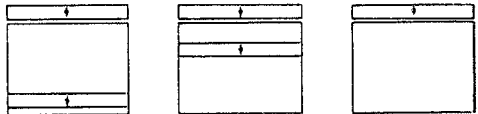
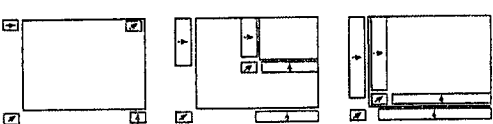
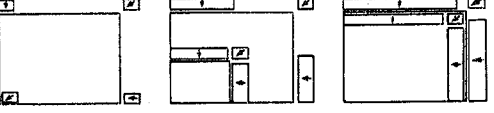
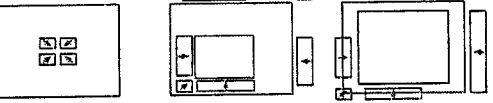
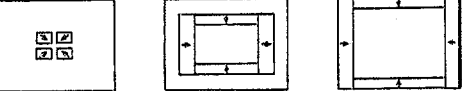
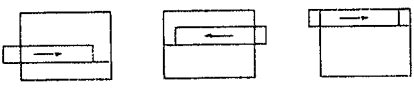
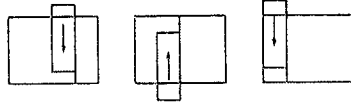
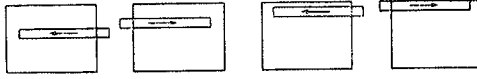
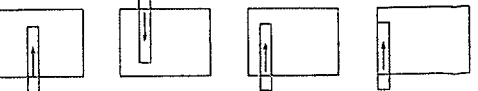

Effect Pattern Image List









Dynamic mirror										
1200										T
1202										T
1204										T
Stream										
1210		1211		1212		1213				T
Accordion										
1231		1233								T
Multi-screen										
1240		(DISSOLVE)		1241		(DISSOLVE)				A
Wave modulation										
1250		1251		1252		1253		1260		T
1261		1262		1263		1264		1265		T
1266		1270								T























Slide			
1300		1301	
1302		1303	
1304		1305	
1306		1307	

Split slide			
1330		1331	
1332			
1340			
1343			
1347			
1349			
1350			
1351			
1360			
1361			
1362			
1363			
1370	1371	1372	1373
			
1380	1381	1382	1383
			

Effect Pattern Image List

Appendixes

Multi-split					
1403		1418		1420	
1432		INT VIDEO			
1447		INT VIDEO			
1451		INT VIDEO			

Compression					
1500				1505	
					
					
1506				1507	
					
					
1508				1510	
1511		1512		1513	
1520		1521		1522	

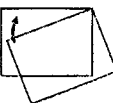
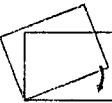
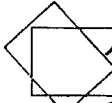
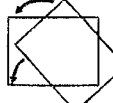
Two-dimensional rotation					
1603		1607		1610	
				1612	

Two-dimensional rotation + Compression+Slide					
1620		T	1630		T
1635		T	1640		T
1643		T	1644		T

Two-dimensional rotation + Compression+Slide (modified)	
1690	<div style="border: 1px solid black; padding: 5px; display: inline-block;"> 2 D (variable) </div> T

Three-dimensional rotation								
1700		T	1701		T	1702		T
1703		T	1704		T	1705		T
1706		T	1707		T			

Door					
1730		T	1731		T
1732		T	1740		T
1741		T	1742		T

Effect Pattern Image List

Appendixes

Three-dimensional rotation+Compression									
1760				T	1762				T
1765				T					

Three-dimensional rotation+Compression+Slide									
1770				T	1780				T
1781				T	1782				T
1783				T	1800				T
1802				T	1806				T
1807				T	1810				T
1811				T	1812				T
1813				T	1814				T
1815				T	1816				T

Flip, tumble











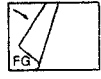

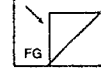

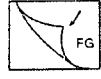
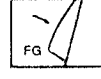
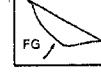
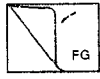

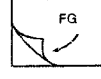
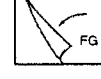
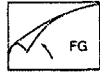
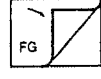

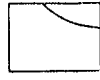
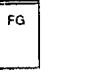
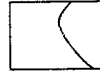
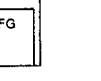
1900		T	1901		T
1902		T	1905		T
1906		T	1909		T
1912		T	1916		T
1920		T	1921		T
1930		T	1933		T
1940		T	1941		T
1942		T	1943		T
1944		T	1945		T
1946		T	1947		T
1948		T	1949		T

Effect Pattern Image List

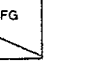
Appendixes

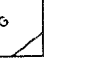
Flip, tumble (continued)					
1950		T	1951		T
1952		T	1954		T
1955		T	1956		T
1958		T	1959		T
1960		T	1962		T
1964		T			

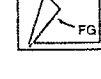
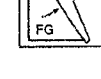
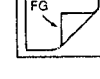
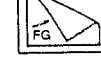
Twist					
2000		T	2002		T
2004		T	2006		T

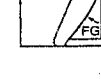
Page turn			
2100		2101	
	T		T
2102		2103	
	T		T
2104		2105	
	T		T
2106		2107	
	T		T
2108		2109	
	T		T
2110		2111	
	T		T
2112		2113	
	T		T
2114		2115	
	T		T
2120		2121	
	T		T
2122		2123	
	T		T
2124		2125	
	T		T
2126		2127	
	T		T
2128		2129	
	T		T
2130		2131	
	T		T
2132		2133	
	T		T
2134		2135	
	T		T
2136		2137	
	T		T

Effect Pattern Image List

Appendixes

Page turn (continued)			
2138		2139	
	T		T
2142		2143	
			T
2144			T

Page turn (modified)			
2150		2151	
	T		T
2152		2153	
	T		T
2154			T

Sphere			
2200		2201	
			T
2202		2203	
			T
2204		2210	
			T
2211		2212	
	T		T
2213			T

Picture-in-picture sphere			
2250		2251	
	A		A

Index

A

A-roll editing 3-7, 7-6, 7-9
A/B-roll editing 3-8, 7-7, 7-10
AD-76 board 2-26
Adjustable parameters A-8, A-9
Advanced operation 6-1
 Changing the direct pattern assignment 6-2
 Snap shot 6-20
 User program 6-4
Animation-type effect 5-2, 5-4, 5-33, 6-5, A-10
AUTO TRANS button 2-5, 5-35

B

BACKGROUND bus button 2-3, 5-2
Background picture 5-2
Backup battery 3-3
B. B. OUT GAIN VR 2-23
BKDF-501/501P 1-5, 2-21
BKDF-502/502P 1-5, 2-22
BKDF-503 1-5
Black-burst signal 2-19
BORD MAT indicator 2-8, 2-9, 2-16, 5-23, 5-37
Border (effect) 5-13
 — (downstream key) 5-28
BORDER button (DOWNSTREAM KEYSER)
 2-10, 5-28
 — (EDGE) 2-13, 5-13
Border matte 2-9, 5-13, 5-37
Built-in video signal 2-3, 5-3
BVE-600 3-7, 3-9, 7-5
BVE-900/910 3-9, 7-12 to 7-17
BVS-3000 3-10, 7-14 to 7-17

C

CLIP control (DOWNSTREAM KEYSER)
 2-11, 5-27
 — (TITLE) 2-8, 5-18
COL BAR indicator 2-3, 5-3
COL BKGD indicator 2-3, 2-9, 5-3
Color background 5-37
Color matte 5-37
 Adjusting the color 5-37
 Copying the color-matte data 5-38

Compound effect 5-20
 Shadow 5-24
 Trail 5-22
 Drop border 5-23
 Lighting 5-21
Connections 3-4
 A-roll editing system connections 3-7
 A/B-roll editing system connections 3-8
 Basic system connections 3-5
 Connections with the BVS-3000 3-10
 Key-signal connections 3-6
CONTROL knob 2-17, 5-22, 5-24
Control panel 2-2
 DOWNSTREAM KEYSER section 2-10
 EDGE section 2-13
 EDITOR ENABLE button 2-17
 EFFECT CONTROL section 2-12
 EFFECT TRANSITION section 2-4
 Keypad section 2-6
 LIGHTING section 2-15
 LOCATION section 2-13
 MATTES/BKGD section 2-9
 Primary crosspoint bus section 2-3
 SNAP SHOT section 2-14
 TITLE section 2-8
 TRAIL/SHADOW section 2-16
 USER PROGRAM section 2-17
 25-pin connector 2-17
Control panel mount adaptor (BKDF-503) 1-5
Control with the editing control unit 7-1
 Control from the BVE-600 7-5
 Control from the BVE-900 series 7-12
 Control from the BVS-3000 series 7-14
 Control from the RM-450 7-2
 Control using the GPI signal 7-8
Controller select switch 2-25, 3-11
Cue signal 2-20, 7-2, 7-3

Index

D

DA-63 board 2-22
DEL button 2-7
Delay 2-23, 2-24
Demonstration (factory setting) 4-9
— (snap shot) 6-23
DENSITY indicator 2-16, 5-24
DENSITY/POSITION button 2-17, 5-24
Digital Multi Effect (DME) 5-4, A-7
DIRECT PATTERN button 2-6, 5-10, 6-2
Direct pattern 5-5, 5-10
Direct pattern assign function 6-2
Direct pattern select mode 5-10
DOUBLE indicator 2-10, 5-28
DOWN button 2-7, 5-12
DOWNSTREAM KEYS section 2-10
 BORDER button 2-10
 CLIP control 2-11
 DSK MIX button 2-11
 EXT KEY button 2-11
 FILL button and indicator 2-11
 KEY INV button 2-10
 MASK button 2-11
 POSITION button and indicator 2-10
 TYPE button and indicator 2-10
Downstream key 2-10, 3-6, 5-25
DROP BORD indicator 2-10, 5-28
DROP BORDER button 2-16, 5-23
Drop border (downstream key) 5-28
— (compound effect) 5-20, 5-23
DSK board (BKPF-502/502P) 1-5
DSK BORD indicator 2-9, 5-37
DSK border matte 5-29
DSK button (EFFECT CONTROL) 2-12, 5-29
— (EFFECT TRANSITION) 2-4, 5-30
DSK indicator 2-4, 5-30
DSK EXT KEY CLIP VR 2-23, 5-27
DSK EXT KEY DELAY switch 2-23
DSK MAT indicator 2-9, 2-11, 5-38
DSK matte 2-9, 5-26
DSK MIX button 2-12, 5-27
DSK VIDEO indicator 2-11, 5-27
DSK VIDEO SELECT switch 2-23
DURATION display window 2-16, 5-22
DURATION indicator 2-16, 5-22
Duration of trail 2-16, 5-22

E

EDGE section 2-13
 BORDER button 2-13
 SOFT button 2-13
 WIDTH/SOFT control 2-13
EDIT button 2-17, 6-12 to 6-17
EDIT display window 2-17, 6-12 to 6-17
Edit (user program) 6-12
EDITOR ENABLE button 2-17
EFFECT button 2-4, 5-30
EFFECT CONTROL section 2-12
 Parameter-setting control 2-19
 Mask-adjustment mode on/off button 2-12
 Mode indicator for parameter-setting controls 2-12
EFFECT indicator 2-4, 5-31
Effect pattern 5-4, A-14
EFFECT TRANSITION section 2-4
 AUTO TRANS button 2-5
 DSK button 2-5
 EFFECT button 2-4
 Fader lever 2-5
 FREEZE button 2-5
 Mode indicators for display window 2-4
 NORM/REV indicator 2-4
 REVERSE button 2-5
 Fader lever torque control 2-5
 TRANS RATE display window 2-4
 Transition indicator 2-5
ENTER button 2-7
EXT KEY button (DOWNSTREAM KEYS)
 2-11, 5-27
 — (TITLE) 2-8, 5-18
External key mode (downstream key) 5-26
— (title key) 5-18
External sync 2-22

Index

F

F1 to F4 controls 2-12, 5-16, A-11 to A-13
Fader lever 2-5, 5-34 to 5-36
Fader torque control 2-5
FIELD button 2-5, 5-31
Field 2-5, 5-31
FILL button (DOWNSTREAM KEYER)
 2-11, 5-26
 — (TITLE) 2-8, 5-18
 — (TRAIL/SHADOW) 2-16, 5-23
FM-29 board 2-24
FOREGROUND bus button 2-3, 5-2
Foreground picture 5-2
FORM control 2-12, 6-8, 6-9
FRAME button 2-5, 5-31
Frame 2-5, 5-31
FREEZE button 2-5, 5-31
Freeze 2-5, 5-31
FRGD BUS indicator 2-8, 5-18
FUNCTION indicator 2-16

G

Gain 2-23
GEN LOCK/H PHASE COARSE switch 2-23
GEN LOCK/H PHASE FINE VR 2-23
GEN LOCK IN indicator 2-22
GEN LOCK/SC PHASE COARSE switch 2-22
GEN LOCK/SC PHAE FINE VR 2-22
GPI (General-Purpose Interface) 3-8, 7-8 to 7-11
GRID indicator 2-3, 5-3

H

HARD indicator 2-16, 5-22
HARD STAR indicator 2-16, 5-22
HOLD INPUT button 2-14, 6-22
Horizontal phase 2-23
HUE control 2-9, 5-37
Hue 2-10, 5-37

I

IN 1 through 4 switches 2-26
Initialize
 Initializing all settings 3-4
 Initializing the assignment of direct pattern
 6-3
 Initializing the control panel 3-4
 Initializing the snap shot 6-23
 Initializing the user program 6-19
INS button 2-7
INT VIDEO SELECT button and indicator
 2-3, 5-3
INTENSITY button 2-15, 5-21
Internal board 2-21
 B.B OUT GAIN VR 2-23
 Controller select switch 2-25
 DSK EXT KEY CLIP VR 2-23
 DSK EXT KEY DELAY switch 2-23
 DSK VIDEO SELECT switch 2-23
 GEN LOCK/H PHASE COARSE switch 2-23
 GEN LOCK/H PHASE FINE VR 2-23
 GEN LOCK IN indicator 2-22
 GEN LOCK/SC PHASE COARSE switch
 2-22
 GEN LOCK/SC PHAE FINE VR 2-22
 IN 1 through 4 switches 2-26
 KEY OUT DELAY switch 2-23
 KEY OUT GAIN VR 2-23
 PGM OUT GAIN COMPONENT VR 2-23
 PGM OUT GAIN COMPOSITE VR 2-23
 PGM OUT GAIN Y/C VR 2-23
 RM-450 TIMING switch 2-25
 TITLE EXT KEY CLIP VR 2-26
 TITLE EXT KEY DELAY switch 2-24
Internal sync mode 2-22
INVERT button (DOWNSTREAM KEYER)
 2-11, 5-29
 — (TITLE) 2-8, 5-19

Index

Index

K

- KEY INV button (DOWNSTREAM KEYS)
 - 2-10, 5-27
 - (TITLE) 2-8, 5-18
- Key frame 6-4, 6-5, 6-13 to 6-17
 - Adding a key frame 6-13
 - Assigning the key-frame data 6-15
 - Copying a key frame 6-16
 - Deleting a key frame 6-14
- Key invert (downstream key) 2-11, 5-29
 - (title key) 2-8, 5-19
- Key mask (downstream key) 2-11, 5-29
 - (title key) 2-8, 5-19
- Key-clipping level (downstream key) 2-11, 5-27
 - (title key) 2-8, 5-18
- Key-fill signal (downstream key) 3-6
 - (title key) 3-6
- KEY OUT DELAY switch 2-23
- KEY OUT GAIN VR 2-23
- Key-source signal (downstream key) 3-6, 5-26
 - (title key) 3-6, 5-18
- Keypad section 2-6
 - DIRECT PATTERN buttons 2-6
 - Mode indicator 2-6
 - PATTERN/KEY PAD buttons 2-7
 - PATTERN NUMBER display window 2-6
 - SET button 2-6
 - SHIFT button 2-6

L

- LEARN button 2-14, 6-21
- Learn 6-21
- LIGHTING section 2-15
 - INTENSITY buttons and indicator 2-15
 - LIGHTING button 2-15
 - TYPE button and indicator 2-15
 - WIDTH button and indicator 2-15
- Lighting 5-20, 5-21
- LINE indicator 2-15, 5-21
- LINEAR indicator 2-12, 6-6
- Linear-type effect 6-5, 6-7
- LOCATION button 2-13
- LOCATION section 2-13
 - LOCATION button 2-13
 - (X)/(Y) joystick 2-13
 - (Z) button 2-13

- LUM control 2-9, 5-37
- Luminance (color matte) 2-9, 5-37
 - (lighting) 2-15, 5-21
- Luminance signal 3-6

M

- MASK button (DOWNSTREAM KEYS)
 - 2-11, 5-29
 - (TITLE) 2-8, 5-19
- MASK indicator (EFFECT CONTROL)
 - 2-12, 5-19, 5-29
- Masking area (downstream key) 5-30
 - (title key) 5-19
- MATTE COPY button 2-9, 5-38
- MATTES/BKGD section 2-9
 - HUE control 2-9
 - LUM control 2-9
 - MATTES/BKGD SELECT button and indicator 2-9
 - MATTE COPY button 2-9
 - SAT control 2-9
- Mode indicator 2-6
- Mode indicator for display window 2-4
- Mode indicator for parameter-setting control 2-12
- MODIFY indicator 2-12
- Modifying a pattern 5-16

N

- NARW BORD indicator 2-10, 5-28
- NON-LIN indicator 2-12, 6-6
- NONE indicator 2-11, 5-26
- Non-linear-type effect 6-5, 6-8
- NORM/REV indicator 2-4, 5-32
- NORMAL button (DOWNSTREAM KEYS)
 - 2-11, 5-29
 - (TITLE) 2-8, 5-19
- Normal (direction) 5-32, 5-33

O

- OFFSET control 2-12, 6-8, 6-9
- Optional board 1-5

P

- Parameter-setting control 2-12, 5-16, 6-6
- Parameters for modifying effect patterns (built-in effects) 5-16, A-11 to A-13
 - (user-program effects) 6-6
- Pattern
 - Location of effect patterns 5-14
 - Modifying a pattern 5-16
- Pattern image 5-5 to 5-9, A-17 to A-26
- PATTERN indicator 2-6, 5-11
- PATTERN KEY/PAD buttons 2-7, 5-10, 5-11
- Pattern number designation mode 5-11
- PATTERN NUMBER display window 2-6
- Pattern signal 5-3
- PERS control 2-13, 6-7, 6-9
- PGM OUT GAIN COMPONENT VR 2-23
- PGM OUT GAIN COMPOSITE VR 2-23
- PGM OUT GIN Y/C VR 2-23
- Picture-in-picture 4-6
- PLANE indicator 2-15, 5-21
- POSITION button 2-10, 5-28
- POWER switch and indicator 2-21
- Primary crosspoint but section 2-3
 - BACKGROUND bus buttons 2-3
 - FOREGROUND bus buttons 2-3
 - INT VIDEO SELECT button and indicators 2-3
- Processor unit 2-18
- Program output 2-18

R

- Rear panel 2-18
 - AC IN connector 2-20
 - BLACK BURST OUT 1 through 4 connectors 2-19
 - CONTROL PANEL connector 2-19
 - DSK KEY IN connectors and 75-ohm termination switch 2-18
 - DSK VIDEO IN connectors and 75-ohm termination switch 2-19
 - EDITOR connector 2-20
 - EXT KEY IN connector 2-19
 - GEN LOCK IN connectors and 75-ohm termination switch 2-19
 - Ground terminal 2-20
 - KEY OUT connector 2-19
 - PGM OUT 1, 2 connectors 2-18
 - T1/CUE, T2 connectors 2-20
 - VIDEO INPUTS 1 through 4 connectors 2-19

- RECALL button 2-14, 6-22
- Recall 6-22
- Registration function 6-15
- Replacing the label 6-3
- REVERSE button 2-5, 5-32
- Reverse (direction) 5-32, 5-33
- RM-450 3-7, 7-2 to 7-4
- RM-450 TIMING switch 2-25
- RNDM MAT indicator 2-16, 5-22, 5-23
- ROT (X) control 2-12, 6-7, 6-9
- ROT (Y) control 2-12, 6-7, 6-9
- ROT (Z) control 2-12, 6-7, 6-9
- RST button 2-7

S

- SAT control 2-9, 5-37
- Saturation 2-9, 5-37
- SELF indicator 2-16, 5-23
- Self-key mode (downstream key) 5-26
 - (title key) 5-18
- SET button 2-6, 5-11, 6-10, 6-12, 6-16, 6-18
- SHAD MAT indicator 2-8, 2-9, 2-16
- SHADOW button 2-16, 5-22
- Shadow 5-20, 5-24
- Shadow-matte 2-9, 5-37
- SHIFT button 2-6
- SNAP SHOT section 2-14
 - HOLD INPUT button 2-14
 - LEARN button 2-14
 - RECALL button 2-14
 - SNAP SHOT number display window 2-14
- SNAP SHOT indicator 2-6
- Snap shot 6-20
 - Storing the snap shot data 6-21
 - Recaling the snap shot 6-22
- SOFT button 2-13, 5-13
- SOFT indicator 2-16, 5-22
- SOFT STAR indicator 2-16, 5-22
- Soft edge 2-13, 5-13
- SPOT indicator 2-15, 5-21
- STATUS display window 2-17, 6-12, 6-18
- Subcarrier 2-22
- Superimpose 2-8, 5-17
- Superimposing characters (downstream key) 5-25
 - (title key) 5-27
- SY-172 board 2-25

Index

T

- Timing of freeze 2-25
- TITLE button (EFFECT CONTROL) 2-12, 5-19
 - (TITLE) 2-8, 5-17
- TITLE section 2-8
 - CLIP control 2-8
 - EXT KEY button 2-8
 - FILL button and indicator 2-9
 - KEY INV button 2-8
 - MASK button 2-8
 - TITLE button 2-8
- TITLE EXT KEY DELAT switch 2-24
- TITLE EXT KEY CLIP VR 2-26
- Title key 2-8, 3-5, 5-17
- TRAIL button 2-16, 5-22
- Trail 5-20, 5-22
- Trail and Lighting board (BKDF-501/501P) 1-5, 2-21
- TRAIL/SHADOW section 2-16
 - CONTROL knob 2-17
 - DENSITY/POSITION button 2-17
 - DURATION display window 2-16
 - FILL button and indicator 2-16
 - FUNCTION indicator 2-16
 - TYPE button and indicator 2-16
 - Compound effect select buttons 2-16
- TRANS indicator 2-6
- TRANS RATE display window 2-4, 5-30
- Transition 2-4, 5-30
 - Direction of transition 5-32
 - Duration of transition 5-30
 - Transition-Indicator 2-5, 5-36
- Transition-type effect 5-2, 5-4, 5-33, 6-5, A-10
- Trigger signal 2-20, 7-5
- TYPE button (DOWNSTREAM KEYS) 2-10, 5-28
 - (LIGHTING) 2-15, 5-21
 - (TRAIL/SHADOW) 2-16, 5-22
- Type of effects A-7
- Type of motion A-10

U

- UP button 2-7, 5-12
- USER PGM indicator 2-6
- USER PROGRAM section 2-17
 - EDIT display window 2-17
 - EDIT button 2-17
 - STATUS display window 2-17
- User-modify effect 5-4, 5-16, A-11 to A-13
- User program 6-4
 - Required conditions for user-program effect 6-4
 - Creating a user-program effect 6-10
 - Editing a user-program effect 6-12
 - Executing a user-program effect 6-18
 - Deleting user-program effect 6-19
 - User-program edit mode 2-17

W/X/Y/Z

- WID/POS indicator 2-16, 5-23, 5-24
- WIDE BORD indicator 2-10, 5-28
- WIDTH button 2-15, 5-21
- WIDTH/SOFT control 2-13, 5-13
- Wipe 4-3, 5-5, 5-6
- (X)/(Y) joystick 2-14, 5-14 to 5-16, 6-7, 6-8
- (Z) control 2-13, 5-15 to 5-16, 6-7, 6-8

Index