

WYSE  
| | | |

WY-85  
*User's  
Guide*

Keyboard-1  
DISPLAY  
DISPLAY  
DISPLAY  
DISPLAY  
DISPLAY

### ***Copyright Notice***

© 1985, Wyse Technology. All rights reserved.

This guide and the firmware described in it are copyrighted by Wyse Technology. You may not reproduce, transmit, transcribe, store in a retrieval system, or translate into any language or computer language, in any form or by any means, electronic, mechanical, magnetic, optical, chemical, manual, or otherwise, any part of this publication without the express written permission of Wyse Technology.

### ***Disclaimer***

Wyse Technology makes no representations or warranties regarding the contents of this document. We reserve the right to revise this document or make changes to the specifications of the product described within it at any time without notice and without obligation to notify any person of such revision or change.

### ***Trademarks***

WYSE® is a registered trademark of Wyse Technology

WY-85™ is a trademark of Wyse Technology

Centronics® is a registered trademark of Centronics Data Computer Corporation

IBM® is a registered trademark of International Business Machines

Dysan® is a registered trademark of Dysan Corporation

Hayes Smartmodem® is a registered trademark of Hayes Microcomputer Products, Inc

VT52™, VT100™, and VT200™ are trademarks of Digital Equipment Corporation

DEC® is a registered trademark of Digital Equipment Corporation

**WYSE**  
| | | | |

**WY-85**  
*User's*  
*Guide*





# Overview

By reading this guide you will be able to quickly install and set up your WY-85 terminal.

The companion guide, the *WY-85 Programmer's Guide*, tells you how to write programs to utilize the terminal's features. To order the *WY-85 Programmer's Guide* simply fill out the business reply card at the back of this guide and mail it to us.

This manual contains four chapters and three appendices:

Chapter 1 contains installation procedures that include unpacking the terminal and attaching a computer, printer, and modem.

Chapter 2 discusses the setup mode. You may have to enter the setup mode to change the terminal's parameters so that it can communicate with a computer, printer, or modem. This chapter also contains instructions to program the function keys.

Chapter 3 describes the capabilities of the terminal including the keyboard (description of each key), multikey commands, communication modes, and special features (i.e., scrolling speed).

Chapter 4 discusses simple troubleshooting procedures for problems such as a locked keyboard or blank screen.

Appendix A contains the terminal specifications.

Appendix B provides connector pin assignments.

Appendix C contains the recognized command sequences.



# Table of Contents

## **1 Installation**

Getting Ready	1-2
Connecting the Terminal to a Computer	1-3
Connecting a Modem	1-7
Connecting a Printer	1-8
Turning on the Terminal	1-9
Adjusting the Terminal	1-10
Completing Installation	1-11

## **2 Configuring the Terminal**

Entering Setup Mode	2-2
Changing the Setup Parameters	2-4
Leaving Setup Mode	2-27

## **3 Terminal Capabilities**

Keyboard Description	3-2
Additional Features	3-10
Operating Modes	3-11

## **4 Troubleshooting**

Introduction	4-2
Symptoms and Solutions	4-2

## **Appendices**

A Terminal Specifications	A-1
B Connector Pin Assignments	B-1
C Recognized Command Sequences	C-1

<b>Index</b>	<b>I-1</b>
--------------	------------

## ***List of Tables***

2-1	Setup Levels _____	2-4
2-2	Directory Functions _____	2-7
2-3	Display One Setup Parameters _____	2-8
2-4	Display Two Setup Parameters _____	2-9
2-5	General One Setup Parameters _____	2-10
2-6	General Two Setup Parameters _____	2-12
2-7	Communications One Setup Parameters _____	2-13
2-8	Communications Two Setup Parameters _____	2-15
2-9	Printer One Setup Parameters _____	2-17
2-10	Printer Two Setup Parameters _____	2-19
2-11	Keyboard One Setup Parameters _____	2-20
2-12	Keyboard Two Setup Parameters _____	2-21
2-13	Send Setup Parameters _____	2-22
3-1	Main Keypad Functions _____	3-3
3-2	Editing Keypad Functions _____	3-5
3-3	PF and Function Key Functions _____	3-7
B-1	COMM Port Configuration _____	B-1
B-2	PR Port Configuration _____	B-3
B-3	20 mA Port Configuration _____	B-4
B-4	Typical Modem Pin Assignments _____	B-4
B-5	Sample Printer Connections _____	B-5



# 1

## *Installing the Terminal*

This chapter provides detailed illustrated installation instructions for your terminal.

<b><i>Getting Ready</i></b> _____	1-2
Unpacking and inspecting the terminal	
<b><i>Connecting the Terminal to a Computer</i></b> _____	1-3
Connecting the terminal cables to a computer	
<b><i>Connecting a Modem</i></b> _____	1-7
Connecting a modem to your terminal	
<b><i>Connecting a Printer</i></b> _____	1-8
Connecting a printer to your terminal	
<b><i>Turning on the Terminal</i></b> _____	1-9
Describes self-test and status messages	
<b><i>Adjusting the Terminal</i></b> _____	1-10
Adjusting the position and brightness of the terminal	
<b><i>Completing Installation</i></b> _____	1-11
Discusses internal setup requirements	

## ***Getting Ready***

As you unpack your terminal, make sure you received everything shown below. If anything is missing or visibly damaged, contact the dealer from whom you purchased the terminal.

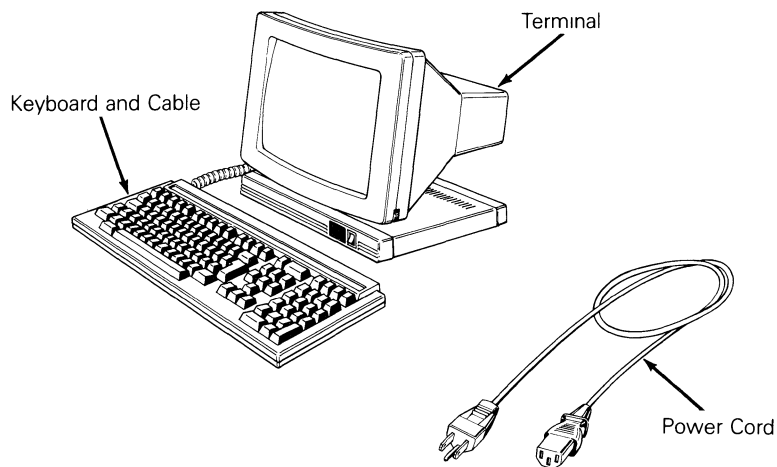

The keyboard cable and the power cord come with your terminal. You'll also need an RS-232C interface cable (fitted with a female 25-pin connector on one end) to connect the terminal to your computer. To connect a serial-type printer directly to your terminal, you'll need a second RS-232C interface cable. These cables can be purchased from your dealer.

The terminal should be located in an area

- Near a grounded, three-pronged power outlet.
- In an area with indirect lighting, and away from windows, if possible. Nearby windows should be on either side of the terminal.
- Large enough to allow three inches of space around the terminal for ventilation.

## ***Connecting the Terminal to a Computer***

To connect the terminal to your computer

1. Press the bottom half of the power switch on the front of the terminal's base to the off position.

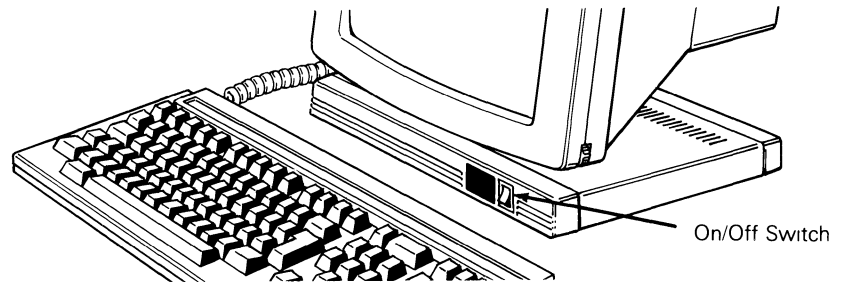

2. Plug the coiled cable into the socket labeled KYBD on the back of the terminal and into the keyboard.

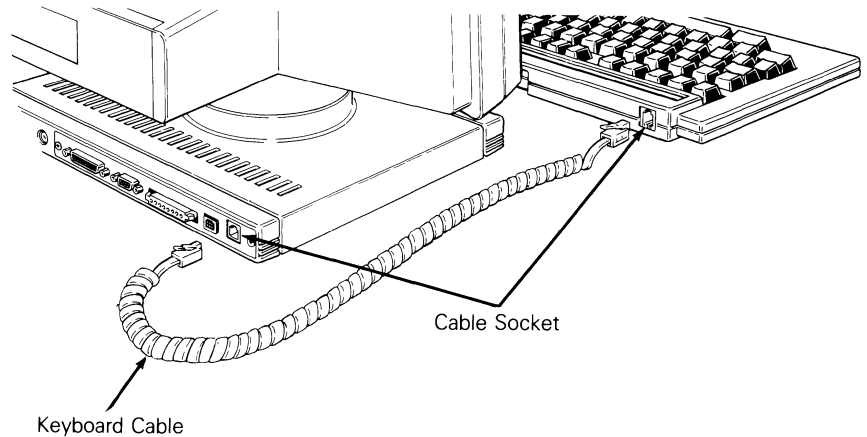

3. Plug the slotted (female) end of the power cord into the three-pronged connector on the back of the terminal.

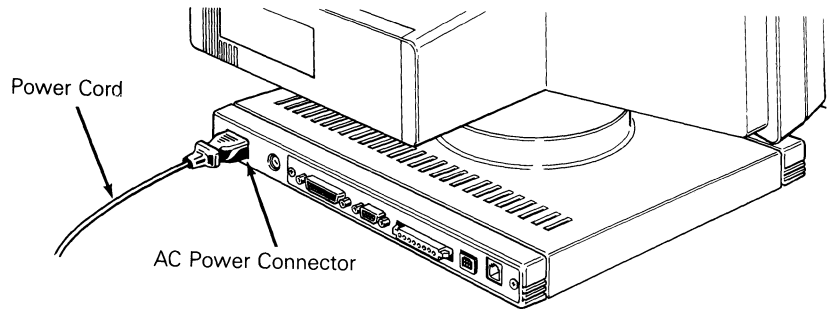

4. The power requirements shown on the label on the back of the terminal should match the voltage in your area. If not, return your terminal to the factory (or contact your distributor) to change the setting.

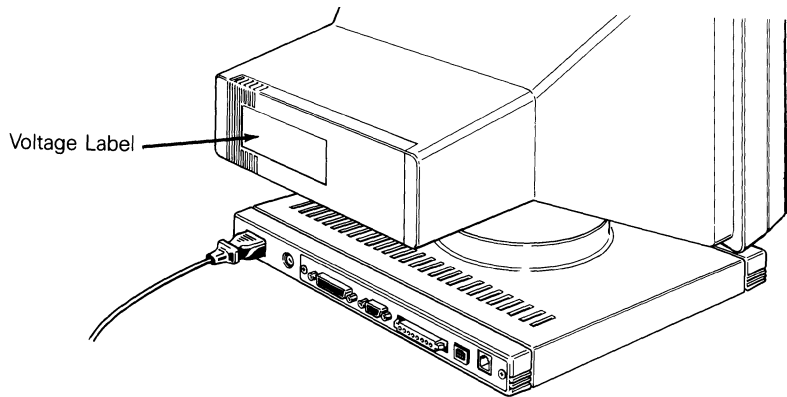

5. Plug the pronged end of the power cord into a three-pronged (in the U.S.), grounded power outlet (or use an adapter for a two-pronged outlet). However, if you only have a two-pronged power outlet, be sure to ground the outlet by attaching the adapter's pigtail to the faceplate screw.

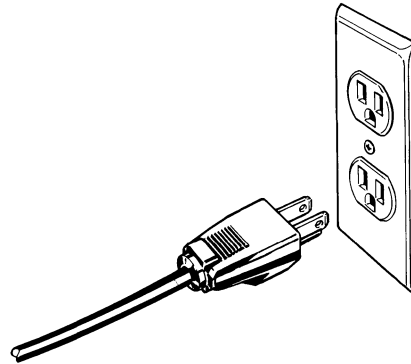

6. Locate your computer's interface cable. It should be an EIA-standard RS-232C or RS-423 cable with a female 25-pin connector on at least one end. If you're connecting a computer configured for current loop (such as a DEC), the interface cable will be an 8-pin, male 20mA connector (MATE-N-LOK).

- **Note** –Not every computer has the same configuration on its RS-232C port. If the pin connector on the RS-232C cable isn't configured to meet the requirements of the computer and the terminal, they won't work as expected (or may not work at all). The pin assignments of the terminal's ports are listed in Appendix B. If the connection pins differ, you should contact the systems analyst for your computer to see about reconfiguration.

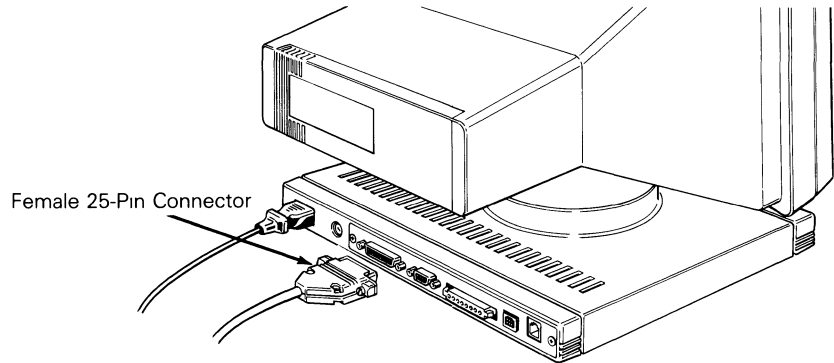

7. Connect the computer interface cable to the terminal's COMM port and to your computer's RS-232C port. If your computer is configured for current loop, connect the 8-pin cable to the terminal's 20mA port and the computer's interface port. The 20mA port is pin-compatible with DEC computers. See Appendix B for pin assignments of the 20mA port.

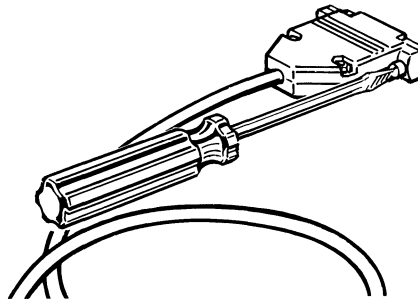

8. With an 1/8-inch, flat-blade screwdriver, tighten the screws on both sides of each connector.

## Connecting a Modem

You can connect a modem to the terminal so it communicates over telephone lines with another computer.

- **Note**—If the pin assignments required by your modem differ from those needed by your computer, you'll need an RS-232C interface cable especially configured for your modem. Your modem may have its own cable. Refer to your modem's reference manual for details.

1. Attach the female end of the 25-pin RS-232C interface cable to the COMM port on the back of the terminal.

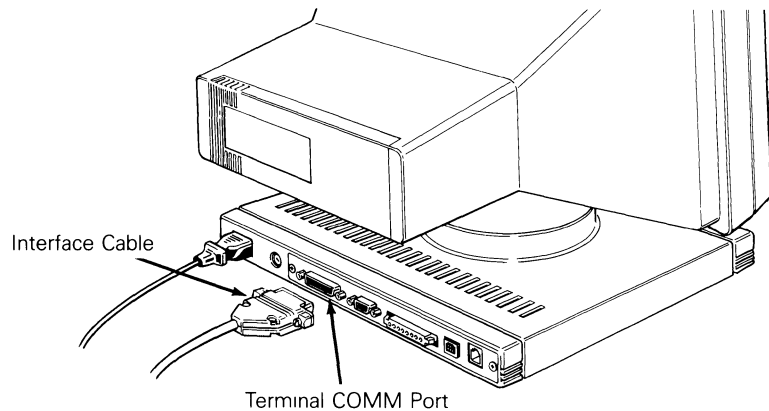

2. Attach the other end of the cable to your modem's RS-232C connector.
3. Follow the instructions in your modem's manual to connect the modem to your telephone.
4. With an 1/8-inch, flat-blade screwdriver, tighten the screws on both sides of each connector to secure the interface.

Appendix B lists the pin connections for the Hayes Smartmodem.

## Connecting a Printer

If your software supports a printer connected to a terminal, you can connect a serial printer directly to the terminal. You'll need an RS-232C interface cable with a 9-pin, D-shaped female connector on one end.

1. Plug the printer interface cable into the PR port on the back of the terminal.

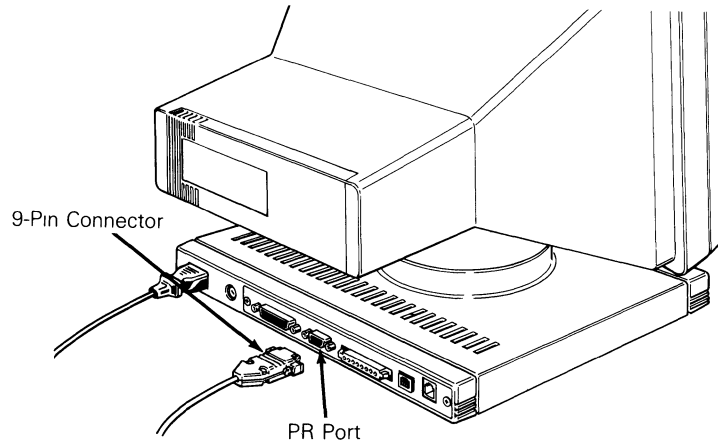

2. With an 1/8-inch, flat-blade screwdriver, tighten the screws on both sides of each connector until secure.
3. Attach the other end of the interface cable to the RS-232C port on the printer.

■ **Note**—The TEST port is for manufacturing purposes only. Do not use this port.

Appendix B lists typical pin connections for a printer.



## *Turning on the Terminal*

After the terminal is properly installed, turn it on by pressing the top half of the terminal's power switch. Listen for an immediate beep indicating that it has received power.

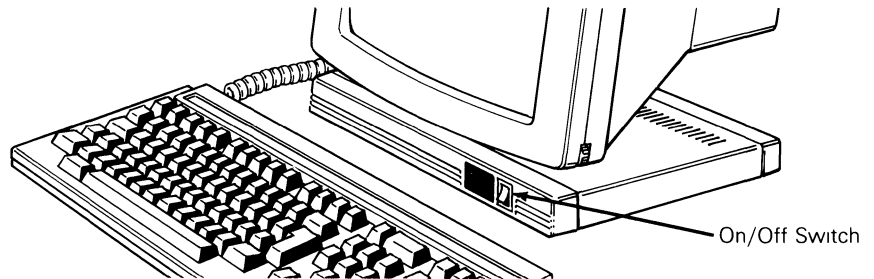

Whenever you turn the terminal on, it automatically runs a five-second self-test. If the terminal has recently been on and the cathode ray tube (CRT) is warm, the screen flashes several display patterns as the self-test runs.

If the terminal encounters a problem during the self-test, a beep sounds and an error code appears in the bottom right-hand corner of the screen. You can't operate the terminal if certain error messages are shown; it may need to be serviced by a qualified technician.

- **Note**—If you see an **X** or **Y** in the bottom right corner of the screen, see the Troubleshooting chapter.

To reset the terminal so that it will rerun its self-test, press the SHIFT key, CTRL key, and SETUP (F3) key simultaneously.

When the cursor is in the upper left corner of the screen, the terminal has passed all of its tests and is ready for operation.

The next thing to appear on the screen is the message line. **LINE**, **LOCL**, **ECHO**, or **BLCK** appear at the top left part of the screen. Later you may see messages about the terminal (called terminal status messages) above the left half of the line. Messages from the computer may appear above the right half of the line.

## ***Adjusting the Terminal***

Adjust your terminal so that the center of the screen is slightly below your eye level. Swivel the screen sideways and up and down until you find the most comfortable angle.

If you want the keyboard tilted slightly, turn it over and pull out the hinged bars. Typing will be more comfortable if the keyboard is at or below your elbow height.

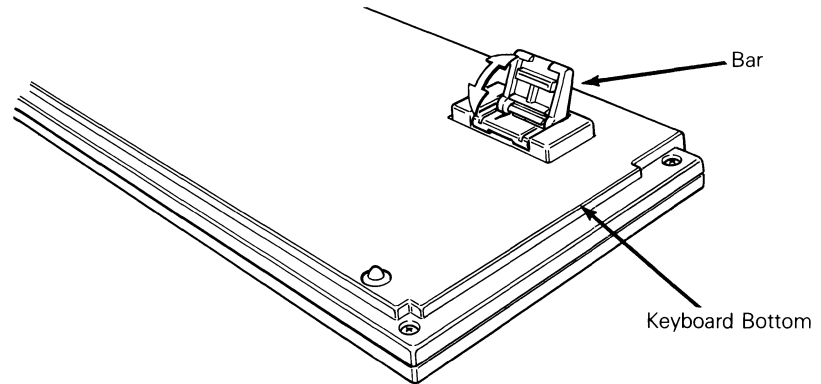

Adjust the intensity of the screen display by turning the brightness control thumbwheel located at the lower front right corner of the terminal.

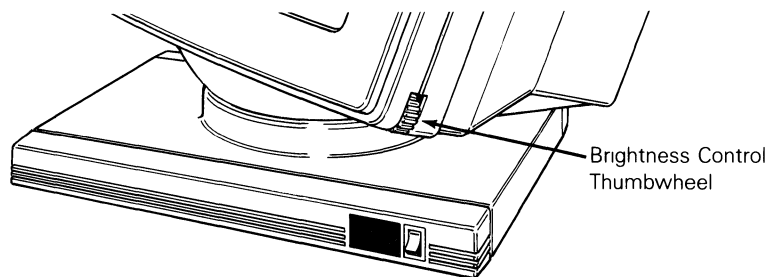

## ***Completing Installation***

Now you've completed the physical installation of the terminal. Before the terminal and computer can communicate, however, you must check the terminal's setup parameters. This is explained in detail in Chapter 2.

# 2

## *Configuring the Terminal*

This chapter discusses the setup mode, which includes the keyboard, communication, printer, and send levels.

<b><i>Entering Setup Mode</i></b> _____	2-2
Describes the setup mode and how to enter it	
<b><i>Changing the Setup Parameters</i></b> _____	2-4
Describes the setup directory and its function; and each setup level	
<b><i>Leaving Setup Mode</i></b> _____	2-27
Describes how to exit the setup mode	

## Introduction

The terminal and computer must have a common language to communicate. This language is determined by a set of variables called parameters. You can change the values of your terminal's parameters in the setup mode to enable the terminal to communicate with many manufacturers' computers.

The way a terminal's parameters are set make up its configuration. The configuration of your terminal and computer (or other device) must match.

Your terminal has a set of default values. Since these default values may not exactly match the device you want to attach, you may need to change some of these values.

In setup mode, you can also change optional parameters, such as the number of columns displayed on the screen or your cursor attributes, as well as program a set of user-defined function keys to perform desired functions.

## Entering Setup Mode

Enter setup mode by pressing the SETUP (F3) key. During setup mode, the cursor temporarily disappears, but reappears when the terminal is in its normal mode. The information you enter remains frozen on the screen and cannot be altered.

- ▼ **Caution** –Do not enter setup mode while data is being transmitted between the terminal and the computer. The terminal cannot receive data during setup mode.

A row of boxes (called *fields*) appear at the top of the screen in setup mode. Each field defines the function of a special key. The fields on the bottom of the screen contain text. These fields make up the setup line and display the parameters you can define for the terminal. See the following figure.

The highlighted field on the setup line is the active field, or the field whose values you can change. Activate desired fields by pressing the ◀ or ▶ cursor key.

The setup line has 44 levels arranged in the order shown in Table 2-1. Each setup level displays a different set of parameters. Table 2-1 lists the setup levels and describes the features you can change in each.

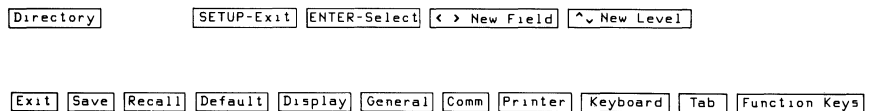

**Table 2-1 Setup Levels**

<b>Level</b>	<b>Display</b>	<b>Function</b>
0	Setup Directory	Main level—accesses other menus, saves data, and exits.
1	Display One	Changes the visual display mode of the terminal.
2	Display Two	
3	General One	Sets general terminal operating characteristics (i.e., how the terminal interprets a pound (#) sign).
4	General Two	
5	Communications One	Sets communications modes and protocols.
6	Communications Two	
7	Printer One	Sets printer modes and protocols.
8	Printer Two	
9	Keyboard One	Sets keyboard modes.
10	Keyboard Two	
11	Send	Sets function keys and data transmission mode.
12	Answerback	Defines answerback message.
13	Tabs	Defines tab stops.
14–28	F6 S to F20 S	Defines the shifted (S) function keys.
29–43	F6 U to F20 U	Redefines the unshifted (U) function keys.

### ***Changing the Setup Parameters***

The first time setup mode is entered, default values appear. Depending on your requirements, you'll probably need to change some of these values.

You can make either device-dependent or optional changes. Optional features, such as a blinking cursor, are a matter of preference and can be changed according to your needs. Device-dependent features must be set according to the requirements of your attached device (modem, printer, etc.).

Consult the user's manual for your computer, modem, and/or printer to determine these device-dependent requirements. Fill in the table below for a record of your device requirements.

	Computer	Printer	Modem	Other
Baud rate	_____	_____	_____	_____
Data bits	_____	_____	_____	_____
Parity type	_____	_____	_____	_____
Handshaking protocol	_____	_____	_____	_____
Stop bits	_____	_____	_____	_____

The following sections describe each setup level, the parameters you can access through them, and the selections available for each parameter.

### *The Setup Directory (Level 0)*

You begin with the setup directory each time you enter setup mode. From this directory you can move to any of the other levels, save changes, reset the terminal's parameters to its default values, or exit setup mode.

Press the SETUP key (F3) to enter setup mode and display the setup directory.

Display-1   SETUP-Dir   ENTER-Next Choice   < > New Field   ^v New Level

Column: 80   Controls Interpret   Autowrap ON   Scroll: Jump   Screen Dark   Rows: 24

The top row of fields on the screen in the setup directory defines the keys you will use to change the values of the parameters on the bottom setup line of the screen. You'll make changes with the cursor keys, spacebar, ENTER key, and the SETUP (F3) key.

Press the ► or ◀ key to highlight a parameter. Press the spacebar or ENTER key to cycle through the possible values of your selected parameter. The choice displayed is the currently active parameter. To return all parameters to their default values, press the ENTER key while you're in the main directory with the Default field highlighted.

Table 2-2 lists the setup directory fields and describes the actions they perform.

**Table 2-2 Directory Functions**

<b>Field</b>	<b>Action</b>
Exit	Exits setup mode and returns to normal terminal operation (same as pressing the SETUP key).
Save	Saves changes in nonvolatile (permanent) memory. When saving changes, the screen goes blank for two to five seconds.
Recall	Restores all parameters to the selections previously saved in memory. The top and bottom screen lines will blank for two seconds. This function clears the soft font and volatile function key data.
Default	Sets all parameters to default values. These values are not saved in nonvolatile memory unless you perform a Save. The top and bottom screen lines will blank for two seconds. This function clears the soft font and volatile function key data.
Display	Enters the first Display setup level.
General	Enters the first General setup level.
Comm	Enters the first Communications setup level.
Printer	Enters the first Printer setup level.
Keyboard	Enters the first Keyboard setup level.
Tab	Enters the Tabs setup level.
Function Key	Enters the Function Key setup level.

You can enter key setup levels by selecting commands from the setup line. You can access unlisted (hidden) levels from nearby levels by pressing the ▲ or ▼ cursor key. To enter the Answerback level, for example, you could select Tab from the setup directory, then press the ▲ key once.

### ***The Display Setup (Levels One and Two)***

The Display setup levels control the visual display of the terminal.

Table 2-3 describes the parameters you can set in the first Display setup level and their possible settings. The default settings are listed first.



**Table 2-3 Display One Setup Parameters**

<b>Parameter</b>	<b>Settings</b>	<b>Explanation</b>
Columns	80	Terminal displays an 80-column screen width.
	132	Terminal displays a 132-column screen width.
Controls	Interpret	Terminal executes escape sequences and control codes but does not display them.
	Display	Terminal displays escape sequences and control codes but does not execute them.
Autowrap	ON	After the cursor reaches the end of a line, it advances to the start of the next line (wraparound).
	OFF	When the cursor reaches the end of a line, it does not advance.
Scroll	Jump	The screen displays data at the rate it's received.
	Smooth-8	The screen scrolls smoothly, eight lines per second.
	Smooth-4	The screen scrolls smoothly, four lines per second.
	Smooth-2	The screen scrolls smoothly, two lines per second.
	Smooth-1	The screen scrolls smoothly, one line per second.
Screen	Dark	Screen has light characters and dark background.
	Light	Screen has dark characters and light background.
Rows	24	The number of data lines displayed is 24.
	25	The number of data lines displayed is 25.

Table 2-4 describes the second Display setup parameters and their possible settings, with default settings listed first.

***Table 2-4 Display Two Setup Parameters***

<b>Parameter</b>	<b>Settings</b>	<b>Explanation</b>
Cursor	Blinking block	Blinking rectangular cursor.
	Steady block	Nonblinking rectangular cursor.
	Blinking line	Blinking underline cursor.
	Steady line	Nonblinking underline cursor.
	OFF	No cursor.
CRT Saver	OFF	Disables screen saver feature and data on the screen is always displayed, regardless of the terminal activity.
	ON	The screen saver feature is on, prolonging the life of the screen's phosphor. If the terminal does not receive data for 15 minutes, the screen blanks until you press a key, but data is not lost.
Width Change Clear	ON	Screen clears when the screen column width is changed.
	OFF	Screen is not cleared when the screen width is changed.
Status Line	ON	The terminal's status line (top line) is displayed.
	OFF	The terminal's status line is not displayed.

### ***The General Setup (Levels Three and Four)***

Parameters in the General levels determine general operating characteristics of the terminal, such as how the terminal interprets a pound sign (#).

Table 2-5 describes the parameters that can be set from the first General setup level and the settings available for each, with default settings listed first.

***Table 2-5 General One Setup Parameters***

<b>Parameter</b>	<b>Settings</b>	<b>Explanation</b>
Mode	VT200 7 Bit	Terminal can run programs written for a DEC VT200 with 7-bit ANSI mode.
	VT200 8 Bit	Terminal can run programs written for a DEC VT200 with 8-bit ANSI mode.
	VT100	Terminal can run programs written for a DEC VT100. Most VT100 programs can also run in the VT200 7-bit mode.
	VT52	Terminal can run programs written for a DEC VT52 (ATS) terminal using nonANSI private codes.
Pound	#	Terminal interprets the 23H character as the American pound symbol (#).
	£	Terminal interprets the 23H character as the British pound symbol (£).
Fkey Lock*	OFF	Shifted function keys F6 through F20 can be redefined by the computer.
	ON	Shifted function keys F6 through F20 can't be redefined by the computer.
Feature Lock	OFF	User-preference features can be redefined from the computer.
	ON	User-preference features can't be redefined from computer.

\*This feature cannot be saved in nonvolatile memory. Its status at power-on is always off.

**Table 2-5 Continued**

<b>Parameter</b>	<b>Settings</b>	<b>Explanation</b>
Newline	OFF	Pressing the RETURN key sends only a carriage return (CR) code. A linefeed (LF) is not interpreted as a CR LF.
	ON	Pressing RETURN sends a CR LF combination. LF is interpreted as CR LF. CR is interpreted as CR.
Local	OFF	Terminal is in conversational mode; it processes all data from the computer normally.
	ON	Terminal is in local mode; it ignores all data from the computer and processes all keyboard data locally.

The affected user-preference features are key repeat, scroll speed, screen color (reverse/normal), tab stops, and keyboard lock. Select OFF when your software controls these features.

Table 2-6 describes the second General setup parameters and their optional settings, with default settings listed first.

**Table 2-6 General Two Setup Parameters**

<b>Parameter</b>	<b>Settings</b>	<b>Explanation</b>
Keypad	Numeric	The keypad on the right side of the keyboard generates numeric codes.
	Application*	The keypad generates escape sequences. See the <i>WY-85 Programmer's Guide</i> for details.
Cursor Keys	Normal	The cursor keys generate the usual cursor motion commands.
	Application*	The cursor keys generate special cursor key application commands. See the <i>WY-85 Programmer's Guide</i> for details.
Transfer Term	Cursor	Print (to printer) and send (to computer) operations end with the character at the cursor position.
	Screen End	Print screen and send screen operations end at the last character on the screen regardless of cursor position; print line and send line operations end at the last character on the cursor line.
Test	OFF	For normal operation.
	ON	DO NOT SELECT; for factory use only.

\*This feature cannot be saved in nonvolatile memory. Power-on status is always normal.

### ***The Communications Setup (Levels Five and Six)***

Communications parameters are set according to the requirements of the device with which the terminal is communicating.

Table 2-7 describes the parameters you can set at the first Communications level and the optional settings for each, with default settings listed first.

**Table 2-7 Communications One Setup Parameters**

<b>Parameter</b>	<b>Settings</b>	<b>Explanation</b>
Transmit	9600	Sets COMM port baud rate (speed at which the terminal sends data to the computer), expressed as bits per second (bps).  If the computer is receiving more data than it can process, it must stop the terminal transmission by sending an XOFF character or lowering the DSR or CTS signal. Alternately, you may select the appropriate value for the XMT LIMIT to slow terminal data transmission. See the Communications Two setup parameter.
	19200	
	38400	
	50	
	75	
	110	
	134.5	
	150	
	300	
	600	
	1200	
	1800	
	2000	
2400		
4800		
7200		
Receive	9600	Sets COMM port baud rate for receiving data from the computer.  Some form of handshake (either XOFF or DTR) is always recommended. This is critical for running at speeds greater than 19200 with smooth scroll, or when performing complex commands such as loading soft fonts.
	19200	
	38400	
	50	
	75	
	110	
	134.5	
	150	
	300	
	600	
	1200	
	1800	
	2000	
2400		
4800		
7200		

**Table 2-7 Continued**

<b>Parameter</b>	<b>Settings</b>	<b>Explanation</b>
Data Bits	8	COMM port transmits 8-bit data words to the computer.
	7	COMM port transmits 7-bit data words to the computer.
Parity	None	Terminal doesn't add or check for a parity bit when it communicates with the computer or a modem.
	Odd	Terminal sends and expects odd parity for sending data.
	Even	Terminal sends and expects even parity for sending data.
	Mark	Terminal sends and expects a high (mark) parity bit.
Parity Check	Space	Terminal sends and expects a low (space) parity bit.
	OFF	Terminal does not check parity.
	ON	Terminal checks parity and indicates bad parity bytes with a reverse question mark.
Echo	OFF	Keyboard data is sent only to the computer. Data can be seen on the screen only if the computer echoes it back to the terminal (full duplex).
	ON	Keyboard data is sent to the screen and computer (half duplex).

Table 2-8 describes the parameters available at the second Communications setup level and their possible settings, with default settings listed first.

**Table 2-8 Communications Two Setup Parameters**

<b>Parameter</b>	<b>Settings</b>	<b>Explanation</b>
Handshake	XOFF	Terminal sends an XOFF character to stop data being received from the computer on the COMM port and sends an XON character when it's ready to receive data again. Terminal also stops sending data when an XOFF character is received from the computer on the COMM port and resumes sending when an XON character is received.
	DTR	Terminal lowers the DTR (data transmit) line (pin 20) to stop data being received on the COMM port and raises the DTR line when it's ready to receive data again. XOFF and XON characters received by the terminal on the COMM port are ignored. High is +3 to +12 volts; and low is -3 to -12 volts.
	Both	Terminal uses both DTR and XON/XOFF handshaking protocols with the computer. XON/XOFF characters received from the computer are recognized.
	None	Terminal doesn't use handshaking protocols and it ignores any XON/XOFF characters received.  This parameter must match the requirements of the device connected to the COMM port.



**Table 2-8 Continued**

<b>Parameter</b>	<b>Settings</b>	<b>Explanation</b>
Stop Bits	1	Terminal sends to the computer and expects one bit to signal the end of a data character.
	2	Terminal sends to the computer and expects two bits to signal the end of a data character.
Port	EIA Data	Terminal transmits and receives data through the RS-232C port; only standard data pins are active.
	EIA Modem	Terminal transmits and receives data through the RS-232C port; modem signals are active on the proper pins. See Appendix B for pin definitions.
	20mA	Terminal transmits and receives data through the 20mA current loop port.
Disconnect	2 sec	Terminal disconnects if received signal line detection (RSLD) is lost for two seconds (pin 8).
	60 ms	Terminal disconnects if RSLD is lost for 60 milliseconds (United Kingdom only).
XMT Limit	None	Terminal transmits all data, except reprogrammed key data, as fast as possible.
	150 cps	Terminal transmits all data at a maximum rate of 150 characters per second (cps), regardless of the baud rate.
	60 cps	Terminal transmits all data at a maximum rate of 60 cps, regardless of the baud rate.

### ***The Printer Setup (Levels Seven and Eight)***

The Printer setup levels should be set to match the parameters of your attached printer. These levels also determine the parameter associated with the printer port and printing functions. Tables 2-9 and 2-10 describe the parameters that can be set from the first Printer and second Printer setup levels. The defaults for each are listed first.

***Table 2-9 Printer One Setup Parameters***

<b>Parameter</b>	<b>Settings</b>	<b>Explanation</b>
Speed	4800	Sets PR port baud rate for transmitting and receiving data.
	7200	
	9600	The printer can stop transmission from the terminal by sending an XOFF character or by lowering the DSR signal on the PR port.
	19200	
	110	
	134.5	
	150	Generally, when printer receive mode is enabled on the printer, it sends an XOFF character and/or lowers the DTR signal (as defined in the printer Handshake parameter) if it isn't ready to receive data from the PR port.
	300	
	600	
	1200	
1800		
2000		
2400		
3600		
Data Bits	8	PR port transmits to the computer and expects only 8-bit data words.
	7	PR port transmits to the computer and expects only 7-bit data words.
Parity	None	Terminal doesn't send or expect a parity bit on the PR port.
	Odd	Terminal sends and expects an odd parity bit on the PR port.

**Table 2-9 Continued**

<b>Parameter</b>	<b>Settings</b>	<b>Explanation</b>
Parity	Even	Terminal sends and expects an even parity bit on the PR port.
	Mark	Terminal sends and expects a high (mark) parity bit on the PR port.
	Space	Terminal sends and expects a low (space) parity bit on the PR port.
Stop Bits	1	Terminal sends one stop bit to the printer, signaling the end of a data character.
	2	Terminal sends two stop bits to the printer, signaling the end of a data character.
Handshake	XOFF	When the buffer is almost full, the terminal sends an XOFF character to the printer; when the buffer is almost empty, the terminal sends an XON character.
	DTR	When the buffer is almost full, the terminal lowers the DTR signal (pin 20); when it's almost empty, the terminal raises the DTR signal.
	Both	Terminal uses both DTR and XON/XOFF handshaking protocols.
	None	Terminal uses no handshaking when communicating with the printer. Not recommended.
Terminator	None	Terminal doesn't send a termination character after it completes a print screen operation.
	FF	Terminal sends a form feed (FF) character after a print screen operation.

**Table 2-10 Printer Two Setup Parameters**

<b>Parameter</b>	<b>Settings</b>	<b>Explanation</b>
Print Region	Full Screen	Sends the entire screen during a print screen operation.
	Scroll Region	Sends scroll region during a print screen operation.
Print Data	ASCII	Prints only ASCII characters. Other characters are replaced with underscores or the closest ASCII character.
	Draw/ASCII	Prints only ASCII and line drawing characters. Other characters are replaced with underscores or the closest ASCII character.
	All	Prints all characters.
Print Mode	Normal	The printer prints data only in response to print line and screen commands.
	Auto print	In response to a LF, FF, VT, or autowrap data prints as the cursor moves to the next line (copy print command).
	Controller	All data is sent from the COMM port to the printer without being displayed (transparent print).
PR Receive	OFF	All data from the printer (PR) port (except XON and XOFF characters) is ignored.
	ON	Data from the printer port is treated like data from the keyboard and is sent to the computer.



### ***The Keyboard Setup (Levels Nine and Ten)***

Keyboard parameters determine how the keyboard responds. Many of these parameters, such as keyclick, are a matter of preference. Others, such as the rate at which data generated by function keys is sent, is determined by your computer's requirements. Tables 2-11 and 2-12 describe the parameters that can be set from the Keyboard levels.

***Table 2-11 Keyboard One Setup Parameters***

<b>Parameter</b>	<b>Settings</b>	<b>Explanation</b>
Lock	Caps	LOCK key is a caps lock key. Alphabetic keys generate only uppercase characters.
	Shift	LOCK key is a shift lock key. Alphabetic keys generate uppercase characters and numeric/symbol keys generate only shifted characters.
	Rev	LOCK is a reverse shift key, reversing the sense of the SHIFT key as it pertains to all alphabetic keys.
Keyrepeat	ON	All keys repeat when held down for more than half a second.
	OFF	No keys repeat when held down.
Keyclick	ON	A click sounds each time a key is pressed or repeated.
	OFF	No click sounds when a key is pressed or repeated.
Margin Bell	OFF	No bell sounds when the cursor moves within eight columns of the right margin.
	ON	The bell sounds when the cursor moves within eight columns of the right margin.
Warning Bell	ON	Received BEL (CTRL G) characters sound the bell.
	OFF	Received BEL characters don't sound the bell.
Break	ON	Break sends a break signal for 250 ms on the XMT line.
	OFF	Break doesn't send a signal.

**Table 2-12 Keyboard Two Setup Parameters**

<b>Parameter</b>	<b>Settings</b>	<b>Explanation</b>
Answerback	ON	The answerback message is sent during a communication reconnect, and at power-on.
	OFF	No answerback message is sent during a communication reconnect or at power-on.  To define the answerback message, see “The Answerback Setup Level” in this chapter.
Compose	ON	The COMPOSE CHARACTER key is enabled.
	OFF	The COMPOSE CHARACTER key is disabled.
	DEL/CAN	The unshifted  key generates a “delete character”; shifted, it generates a “cancel character.”
	BS/DEL	The unshifted  key generates a “backspace character”; shifted, it generates a “delete character.”

### ***The Send Setup (Level 11)***

This level allows you to change the way data is transmitted. Table 2-13 describes the parameters that can be set from the Send setup level. Default settings are listed first.

**Table 2-13 Send Setup Parameters**

<b>Parameters</b>	<b>Settings</b>	<b>Explanation</b>
FKKeys	Remote	The code programmed into keys F6 through F20 (unshifted) is sent to the computer, unless the terminal is in local mode.
	Local	The code programmed into keys F6 through F20 (unshifted) is processed locally by the terminal.
Fkey Xmt	60 cps	Data generated by programmed function keys is transmitted at a maximum rate of 60 characters per second (cps), regardless of baud rate.
	150 cps	Programmed function key data is transmitted at a maximum rate of 150 cps.
	Unlim	Programmed function key data is transmitted as fast as possible.
Send	All	Send line and screen commands transmit all characters.
	Erase	Send commands transmit only characters specified as erasable; a record separator character is transmitted in place of one or more contiguous nonerasable character(s).
Send Area	Full Screen	Send screen operations transmit the entire screen.
	Scroll Region	Send screen operations transmit only active scroll region.
Send Term	None	No character is sent after a send screen operation.
	FF	A form feed (FF) is sent after a send screen operation.

### ***The Answerback Setup (Level 12)***

You can ask the terminal to send an answerback message to the computer before it can log on or access an application. The answerback message may act like a password and can be sent automatically by the terminal, or the message can be sent manually from the keyboard. For purposes of confidentiality, you can conceal this password.

The answerback message is transmitted to the computer in the following cases:

- The computer receives the ENQ character and the terminal is in VT200, VT100, or VT52 mode.
- You press the BREAK (F5) key with the CTRL and SHIFT keys.

To define the answerback message:

1. Press the SETUP key (F3) to enter setup mode and display the setup directory.
2. Press the ► key until the Tabs field in the bottom line is highlighted.
3. Press the spacebar or ENTER key to enter the Tabs setup level.
4. Press the ▲ key to enter the Answerback setup level.
5. Press the <X> key to clear the old message, then type the new message (up to 30 characters).

To conceal the answerback message and keep it from being displayed press the REMOVE key at any time on this level. The answerback message is replaced by the word <CONCEALED> and cannot be redisplayed unless you redefine it.

### ***The Tabs Setup (Level 13)***

By default, tab stops are set every eight columns across the screen, beginning with column nine. When you enter the Tabs setup level, the tab stops (indicated by the letter T) are on a line displayed under the setup line at the bottom of the screen. The tab stops aren't numbered, but you can determine the placement of each by moving the cursor across the line and reading the column number displayed in the message field at the top of the screen.

	T	T	T	T	T	T	T	T	T
(column	9	17	25	33	41	49	57	65	73)



You can clear and set tab stops anywhere within the margins from the Tabs setup level:

1. Press the SETUP key (F3) to display the setup directory.
  2. Highlight the Tab field and press the spacebar or ENTER key to enter the Tabs setup level.
  3. With the cursor on the tab line, position tab stops where you want.
- To move the cursor across the line, press the ► or ◀ cursor keys.
  - To clear all tab stops, press the <X> key.
  - To clear an individual tab stop at the cursor position, press the spacebar.
  - To set an individual tab stop at the cursor position, press the T key.
  - To alternately set or clear a tab at the cursor position, press the ENTER key.
  - To restore all the default tabs, press the TAB key.

### ***The Function Key Setup (Levels 14-43)***

The keyboard's function keys can transmit multiple characters with one keystroke. F6 through F20, including HELP and DO, are programmable; you can assign them any number of possible functions.

If the unshifted function keys have never been programmed, they transmit a set of standard default codes. The *WY-85 Programmer's Guide* lists those codes. The shifted function keys are initially blank and perform no function until programmed.

- ▼ **Caution** – Applications that require default values for the unshifted function keys may not run properly if you redefine these keys.

To program a function key:

- **Note** – If the Key Lock parameter (first Keyboard level) is set to On, you won't be able to program the shifted function keys.
1. Press SETUP (F3) to put the terminal in setup mode and display the setup directory.

2. Highlight Function Keys on the setup line and press the spacebar or ENTER key to enter the first Function Key setup level (level 14).
3. Press the ▼ key until you reach the level containing your key; or press the function key you want to change. Shifted function keys (F6 S through F20 S) are programmed in levels 14 through 28. Unshifted function keys (F6 U through F20 U) are in levels 29 through 43.
4. The normal bottom setup line is replaced with a highlighted field, such as

F 1 S
-------

To program the key, just type the characters you want transmitted. You may enter as many characters as there is space in the field, which is generally 80 characters in 80-column mode and 127 characters in the 132-column mode.

To enter a carriage return (CR) code in the sequence, hold down the CTRL key while pressing M (or RETURN). A carriage return counts as one character.

If you make a mistake, press the ⌫ key to erase the entire line or press the ◀ key to erase one character.

5. To display other function key levels, press the ▲ and ▼ keys, or press the desired function key.
6. To stop programming function keys and display the setup directory, press SETUP (F3) or another function key.

For example, to program F7 (shifted) to send the code sequence DIR<CR> (directory-carriage return), follow these steps:

1. Press the SETUP key (F3).
2. Highlight Function Key on the setup line and press the spacebar or ENTER key.
3. Press the ▼ key once or press the F7 key with SHIFT held down.
4. Type  
DIR
5. Press the M key while holding down CTRL, or press RETURN to send a carriage return.
6. To return to the setup directory, press the SETUP key.

To display the disk's directory, you can just press F7 (or whatever key you've defined), instead of having to type in the command

```
DIR<CR>
```

- **Note**—Your computer's response to a transmitted code depends on the program you're running at the time. Different programs may interpret the same code differently.

You can define the function keys as a group to act as either local or remote keys. Local keys are processed at the terminal only; remote keys transmit characters to the computer first. See "Keyboard Two Setup Level" in this chapter.

There are 400 characters available for all function keys. The first 134 characters are saved in nonvolatile memory; characters beyond that are erased when you turn off the terminal. Those 134 characters saved are indicated by full-intensity characters in the function key definition field; those characters erased will appear dim.

The 134 nonvolatile characters are allocated to the first function keys in sequential order (F6 S through F20 S, then F6 U through F20 U). If you redefine the programs of higher priority keys, be aware that you may alter the volatility of characters in lower priority keys. For more information see the *WY-85 Programmer's Guide*.

## ***Leaving Setup Mode***

When you exit setup mode, you have the choice of saving or not saving the changes you made. Changes you make but don't save still take effect after you exit setup mode but only stay in effect until you turn the terminal off. To exit setup mode and save changes:

1. Press SETUP (F3) to display the setup directory.
2. Select the Save function and press the spacebar or ENTER key. The screen blanks for two to five seconds.
3. You automatically exit setup mode after a save operation.

All changes, including new function key definitions, tab stops, and answerback messages (the first 134 characters only), are saved and will still be in effect after the next power-on.

To exit the setup mode without saving changes:

1. Press the SETUP key (F3).
2. Select EXIT and press the spacebar or ENTER key, or press the SETUP key again.

The terminal operates with the changed setup parameter selections. When the terminal is turned on again, the setup parameters will be what they were before you made these changes.

# 3

## *Terminal Capabilities*

This chapter describes the basic capabilities of the terminal: the keyboard, multikey commands, communication modes, and special features.

<b><i>Keyboard Description</i></b> _____	3-2
Describes the main keyboard, numeric keypad, and function keys	
<b><i>Additional Features</i></b> _____	3-10
Discusses scrolling speed, keyclick, graphics characters, compose characters, and monitor mode	
<b><i>Operating Modes</i></b> _____	3-11
Describes communication between computer and terminal: full duplex, half duplex, and block modes	

## Keyboard Description

The keyboard consists of a main keypad, an editing keypad, an auxiliary keypad, and a row of 20 function keys. The main keypad contains the standard alphanumeric keys of letters, numbers, and symbols usually associated with those on a typewriter keyboard. The editing keypad contains cursor movement keys and special editing keys. The auxiliary keypad contains four PF keys and a standard numeric keypad, which is helpful in heavily numeric text such as that used in accounting records. Function keys F1 through F5 perform predefined local functions. Function keys F6 through F20 either generate predefined codes or they may be reprogrammed to generate user-defined codes (see Chapter 2).

Table 3-1 describes the special keys of the main keypad. Table 3-2 describes the special keys of the editing keypad. Table 3-3 describes the PF keys and the function keys.

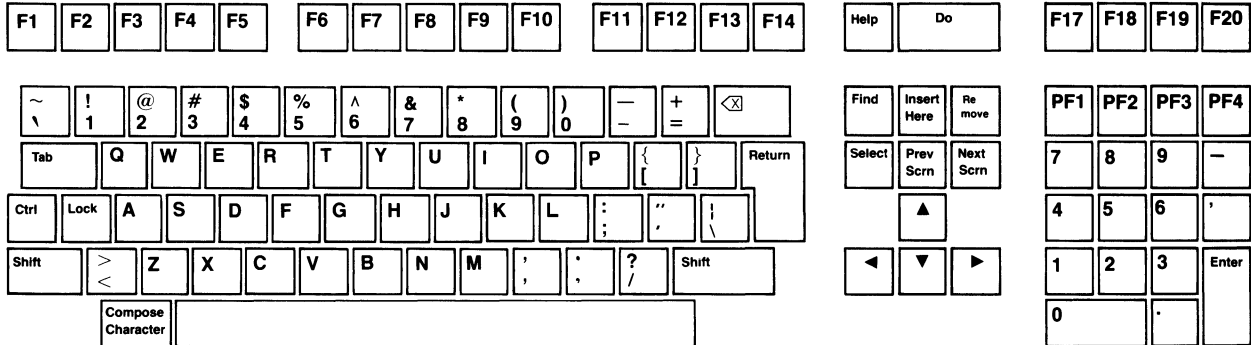

Keys are either local or remote. Local keys cause specific functions to occur, generally without communication to the computer. Remote keys send data to the computer (if the terminal is in full-duplex online mode). This data is interpreted by the computer, which then performs a specific action based on this data.



**Table 3-1 Main Keypad Functions**

<b>Key Description</b>	
<b>COMPOSE CHARACTER</b>	In VT200 mode, this allows you to compose multinational (European) characters not found on the keyboard. In VT100 or VT52 modes, pressing this key simultaneously with another key causes that character to be modified as with the META key found on other terminals. See “Composing Characters” later in this chapter.
<b>CTRL</b>	Pressed simultaneously with another key, CTRL generates a control code. Pressing CTRL by itself has no effect. Normally undisplayed, control codes cause the terminal and/or program to take special action. Press CTRL with SHIFT and SETUP (F3) simultaneously to reset the terminal.
<b>LOCK</b>	<p>Initiates caps lock, shift lock, or reverse shift mode, depending on the selection made for the Lock setup parameter (first Keyboard level, Chapter 2).</p> <p>When Lock is set to CAPS, all alphabetic keys typed appear as uppercase; number and symbol keys are unaffected.</p> <p>When Lock is set to SHIFT, letters are uppercase, and numeric and symbol keys show their shifted character.</p> <p>When Lock is set to REV, the sense of the SHIFT key is reversed as it applies to alphabetic keys. In other words, pressing an alphabetic key simultaneously with the SHIFT key, when the terminal is in the reverse lock mode, generates a lowercase character. Pressing an alphabetic key with the SHIFT key up generates uppercase characters. Number and symbol keys are unaffected.</p> <p>When the terminal is in either caps lock, shift lock, or reverse shift mode, <b>LOCK</b> appears on the status line. Pressing <b>LOCK</b> toggles the terminal in and out of these modes. You can press the SHIFT key to exit the shift lock mode.</p>

**Table 3-1 Continued**

<b>Key</b>	<b>Description</b>
RETURN	Sends a carriage return (CR) code to the computer. The computer's interpretation of this code depends on its program and the Newline parameter (first General setup level, Chapter 2). If Newline is on, a linefeed (LF) code is also sent. This key indicates the end of a data entry to the computer.
SHIFT	When pressed simultaneously with an alphanumeric key, shows the uppercase letter or the upper character shown on the number and symbol keys. Each of the two SHIFT keys function the same. Pressing the SHIFT key by itself has no effect. Press SHIFT, CTRL and SETUP (F3) simultaneously to reset the terminal.
Space Bar	Pressing the space bar creates the space (SP) character.
TAB	Sends the horizontal tab (HT) character. This generally causes the cursor to move to the next tab stop.
 (Delete)	If the  parameter (second Keyboard setup level) is set to DEL/CAN, this key unshifted sends the delete (DEL) character. This generally deletes the character at the cursor and moves the cursor left one position. Pressed with the SHIFT key, the cancel (CAN) character is sent. If the  parameter is set to BS/DEL, this key unshifted sends the backspace (BS) character. This generally moves the cursor left one position. Pressed with the SHIFT key, the DEL character is sent. This generally deletes the character at the cursor and moves the cursor left one position.



**Table 3-2 Editing Keypad Functions**

<b>Key</b>	<b>Description</b>
Cursor Keys	Pressing one of these keys moves the cursor in the direction indicated by the arrow on the key. With the CTRL key held down: Pressing the ▼ selects a slower scrolling rate; pressing the ▲ selects a faster scrolling rate; pressing the ► toggles the status line on and off; and pressing the ◀ toggles the monitor and control execution disable modes on and off.
FIND	Sends the Find command to the computer. The effect of this command depends on the application program being run.
INSERT HERE	In all modes except block mode, pressing this key sends the Insert Here command to the computer. The effect of this command depends on the application program being run. In the block mode, pressing this key toggles the terminal in and out of the insert mode. With the insert mode on, characters are added to the left of the cursor as you type, moving the cursor to the right. With the insert mode off, you type over existing characters.
NEXT SCREEN	In all modes except block mode, pressing this key sends the Next Screen command to the computer. The effect of this command depends on the application program being run.  In block mode, this key clears all text, from the cursor position to the end of the screen.

*Table 3-2 Continued*

<b>Key</b>	<b>Description</b>
PREV SCREEN	In all modes except block mode, this key sends the Previous Screen command to the computer. The effect of this command depends on the application program being run. In block mode, or with the CTRL key held down, it homes the cursor and clears the screen. If the CTRL key is held down while this key is pressed, the screen is cleared and the cursor is sent to the home position, regardless of whether the terminal is in block mode.
REMOVE	<p>In all modes except block mode, this key sends the remove command to the computer. The effect of this command depends on the application program being run.</p> <p>In block mode, this key deletes the character at the cursor position, moving the characters on the right one position left.</p>
SELECT	Sends the Select command to the computer. The effect of this command depends on the application program being run.

**Table 3-3 PF and Function Key Functions**

<b>Key</b>	<b>Function</b>	<b>Description</b>
F1	HOLD SCREEN	If XON/XOFF or DTR handshaking is enabled, the appropriate handshake with the computer is performed. The F1 key toggles data processing on and off. This key is the equivalent of the NO SCROLL key on a VT100 or WY-75 terminal.
F2	PRINT SCREEN	Pressed without CTRL and SHIFT, this key transmits the contents of the screen (from the cursor position to the end of the screen, including protected characters) to the printer. Pressed with CTRL or SHIFT, it toggles in and out of autoprint mode.
F3	RESET/ SETUP	Pressed without CTRL and SHIFT, it puts the terminal in setup mode, displaying the setup directory and setup status line (see Chapter 2). Pressed with CTRL and SHIFT, it performs a hard reset, resetting the terminal to its power-up state. Pressed with only SHIFT, it performs a soft reset, resetting all terminal modes and error conditions.
F4	SEND/ BLOCK	Pressed with SHIFT, it transmits the cursor line. Pressed without SHIFT, it toggles the terminal in and out of block mode.
F5	BREAK	Pressed without SHIFT, it transmits a break signal if the Break parameter (Keyboard one setup level) is on. Pressed with SHIFT, the RTS line on the COMM port is lowered for two seconds. Pressed with both CTRL and SHIFT, the answerback message is transmitted.

**Table 3-3 Continued**

<b>Key</b>	<b>Function</b>	<b>Description</b>
F6-F20 (shifted)		No effect.  F6 through F20, both unshifted and shifted, may be redefined to generate different codes. The following descriptions only apply to F6 through F20 as they are set at the factory, prior to any redefinitions.
F6 (unshifted)		In VT52 and VT100 modes, F6 has no effect. In the VT200 mode, this key sends the F6 command to the computer. The effect of this command depends on the application program being run.
F7 (unshifted)		In VT52 and VT100 modes, F7 has no effect. In the VT200 mode, this key sends the F7 command to the computer. The effect of this command depends on the application program being run.
F8 (unshifted)		In VT52 and VT100 modes, F8 has no effect. In the VT200 mode, this key sends the F8 command to the computer. The effect of this command depends on the application program being run.
F9 (unshifted)		In VT52 and VT100 modes, F9 has no effect. In the VT200 mode, this key sends the F9 command to the computer. The effect of this command depends on the application program being run.
F10 (unshifted)		In VT52 and VT100 modes, F10 has no effect. In the VT200 mode, this key sends the F10 command to the computer. The effect of this command depends on the application program being run.
F11 (unshifted)	ESC	In VT52 and VT100 modes, this key sends the escape character (ESC). Some keys pressed after the F11 ESC key send escape sequences to the computer. The <i>WY-85 Programmer's Guide</i> discusses escape sequences. In VT200 mode, this key sends the F11 command. The effect of this command depends on the application program being run.

*Table 3-3 Continued*

<b>Key</b>	<b>Function</b>	<b>Description</b>
F12 (unshifted)	BS	In VT52 and VT100 modes, this key sends the backspace (BS) character. In VT200 mode, this key sends the F12 command. The effect of this command depends on the application program being run.
F13 (unshifted)	LF	In VT52 and VT100 modes, this key sends the linfeed (LF) character. In VT200 mode, this key sends the F13 command. The effect of this command depends on the application program being run.
F14 (unshifted)	HOME	In VT52 and VT100 modes, this key sends the Home command to the computer, which causes the cursor to move to the top left corner of the screen. In VT200 mode, this key sends the F14 command. The effect of this command depends on the application program being run.
HELP (unshifted)		In VT52 and VT100 modes, this key has no effect. In VT200 mode, this key sends the Help command to the computer. The effect of this command depends on the application program being run.
DO (unshifted)		In VT52 and VT100 modes, this key has no effect. In VT200 mode, this key sends the Do command to the computer. The effect of this command depends on the application program being run.
F17-F19 (unshifted)		In the VT52 and VT100 modes, these keys have no effect. In the VT200 mode, these keys send the F17, F18, or F19 commands to the computer. The effect of these commands depends on the application program being run. In the VT100 and VT52 modes, these keys have no effect.
PF1 through PF4		These keys send escape sequences to the computer that have no effect until these keys are redefined.

## ***Additional Features***

### ***Scrolling Speed***

You can set the general scrolling speed with the Scroll parameter (first Display setup level, see Chapter 2). In addition, you can temporarily alter scrolling speed by pressing CTRL and ▲ to speed up scrolling, and SHIFT with CTRL and ▼ to slow down scrolling. This procedure alters the value of the Scroll parameter, but does not save the change in nonvolatile memory.

### ***Keyclick***

The keyboard has an optional keyclick feature that makes a muted beep each time you press a key. Switch this feature on and off by setting the Keyclick parameter (Keyboard one setup level). You can also switch it on and off by pressing CTRL and ENTER. This procedure alters the values of the Keyclick parameter but does not save the change in nonvolatile memory.

### ***Graphics Characters***

The terminal has several special graphics character sets in addition to its standard characters. However, you can use these additional character sets only with a graphics program that was specially written for them. See the *WY-85 Programmer's Guide* for details.

### ***Compose Characters***

In addition to the standard ASCII character set, you can compose up to 81 multinational (European) characters not found on the keyboard when you are in VT200 7-bit or 8-bit modes. The *WY-85 Programmer's Guide* lists the compose sequences you can type to create new characters.

To compose a new character:

1. Press COMPOSE CHARACTER. **COMP** appears on the status line at the top of the screen.
2. Type the keys required to create the desired character (in the order indicated). Each compose sequence consists of two characters. For example, ^ creates a raised and centered dot (·).
3. When a sequence is entered, the character is sent to your program and **COMP** disappears from the status line. If a sequence is invalid, it's aborted and, if the Warning Bell parameter (first Keyboard setup level) is on, a bell sounds.

### ***Monitor Mode***

You may want to inspect the code characters being sent from the computer. If the terminal is in monitor mode, these code characters appear on the screen with the normal letters. The computer doesn't act on these codes during monitor mode.

To enter monitor mode, press CTRL with the ◀ key, or change the Controls parameter (Display one setup level) to Display. Unless the Status Line parameter (Display two setup level) is set to off, an asterisk (\*) appears next to the communication mode label on the status line. This indicates that the terminal is in monitor mode.

To exit monitor mode, press CTRL with the ◀ key again, and the asterisk disappears.

- **Note**—If the terminal is also in insert mode, an asterisk appears in place of the **INS** label on the status line.

### ***Operating Modes***

The terminal provides three operating modes:

- Setup
- Online
- Local

The setup mode is only selectable from the keyboard. This mode allows you to configure the terminal or to check the previously set configuration (see Chapter 2).

The online operating mode is selectable only in the setup mode by turning off the local mode in the first General setup level. The online mode permits communication between the terminal and the computer in either full-duplex, half-duplex, or block communication modes. The communication modes determine when and where data is transmitted (sent) after you entered it at the keyboard. Half-duplex mode may be selected by the computer or by turning on the Echo field in setup (first Communication level, Chapter 2). Full-duplex mode may be selected either by the computer or by turning off Echo. Block mode may be selected either by the computer or by pressing the F4 key. These three modes also determine how the terminal interacts with the computer. Local mode is only selectable in the setup mode. The following figure illustrates how the terminal handles data in each of these communication modes.

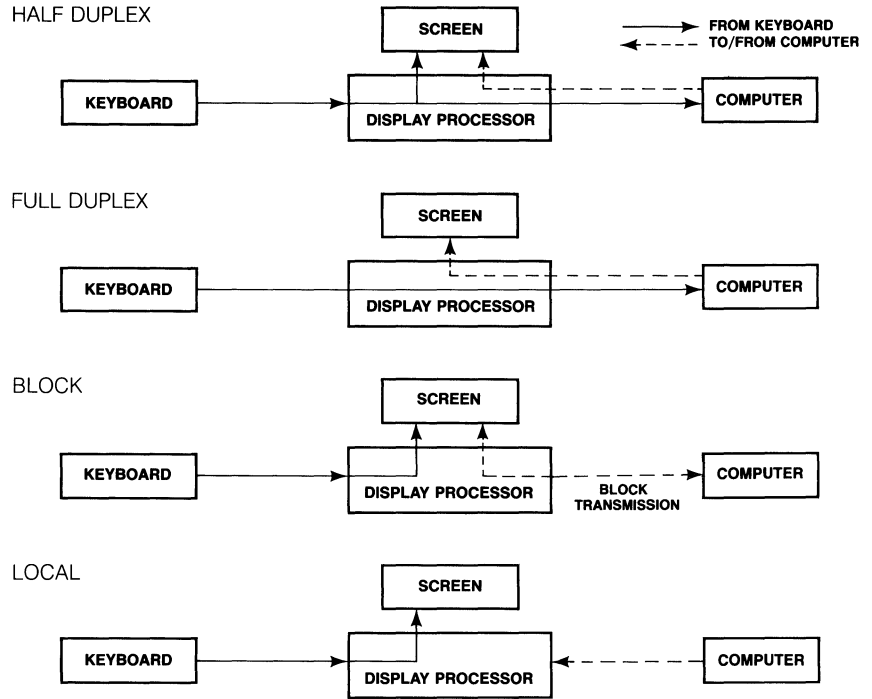

### *Half-Duplex Mode*

In the online half-duplex communication mode, data entered at the keyboard (except escape sequences and control codes) is displayed on the terminal screen and sent to the computer simultaneously; data received from the computer is also shown on the screen. If the terminal is in half-duplex mode and your computer expects it to be in full-duplex mode, the characters you type on the keyboard will appear twice on the screen. When the half-duplex communication mode is selected, **ECHO** is displayed in the status line.



### ***Full-Duplex Mode***

In the online full-duplex communication mode, data entered at the keyboard is sent to the computer and data received from the computer is shown on the screen. In general, this is the normal operating mode. In this mode, **LINE** is displayed in the status line.

### ***Block Mode***

In the online block communication mode, data entered at the keyboard is only displayed on the terminal screen, until you decide to send the block of data to the computer or to the printer. In this mode, data is sent to the computer by pressing the SEND key, or it can be sent directly to the printer by pressing the PRINT SCREEN key. Data received by the terminal from the computer can occur at any time and will be displayed when received. When this mode is selected, **BLCK** is displayed in the terminal status line.

### ***Local Mode***

The local operating mode is only selectable in the setup mode. In local mode, data entered at the keyboard is shown on the display screen, but it is not sent to the computer. Furthermore, data sent by the computer is ignored by the terminal. In this mode, **LOCL** is displayed in the status line. You can work in the local mode to experiment with the various terminal controls without affecting the computer. Here, what you type goes only to the terminal for display on the screen.



# 4

## *Troubleshooting*

This chapter discusses simple troubleshooting procedures.

***Introduction*** \_\_\_\_\_ 4-2

***Symptoms and Solutions*** \_\_\_\_\_ 4-2  
Contains symptoms and possible solutions for  
various terminal problems

## ***Introduction***

For certain problems, the terminal may seem to malfunction when the problem is actually something you can fix yourself. The problem may be the wrong setup value, a loose cable connection, or incorrect pin connections on an interface cable. Before you place a service call, please refer to the solutions listed in this chapter.

- **Warning**—We are NOT suggesting that you try to fix internal problems. Don't open the terminal case unless you are a qualified service technician. When the case is open, dangerous voltages are exposed, even after the power has been turned off.

## ***Symptoms and Solutions***

This section contains symptoms and possible solutions to problems you may encounter with your terminal. The symptom is shown in bold and suggested solutions follow.

### **The terminal doesn't beep when turned on.**

- ▼ **Caution**—The following procedure exposes you to potentially hazardous shock if you don't unplug the power cable.

1. Turn off the power switch and unplug the power cable.
2. Remove the line fuse located on the rear panel next to the power connector by inserting a small flat-head screwdriver into the fuse's slot and turning it counterclockwise.

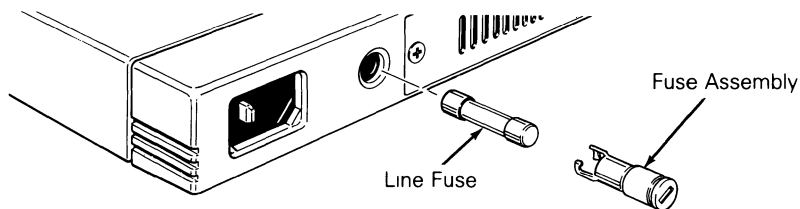

3. If the wire inside the fuse is broken or if the glass is blackened, the fuse may be blown. Replace the fuse only with a 2 amp, 250 volt fuse if this is the case.

4. Reinsert the fuse assembly in the rear panel. While pushing on the fuse assembly with the screwdriver, turn it clockwise about one-half turn. Don't force it.
5. Plug in the power cord and turn on the terminal.

**Terminal beeps after turned on, but you can't see the cursor.**

1. Turn the brightness thumbwheel all the way down (clockwise). See the following illustration.
2. Check the cursor field in the setup mode (Display level two) to make sure the cursor is not set to Off.

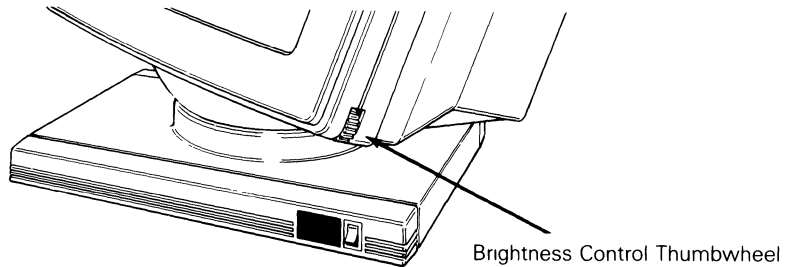

**The screen goes blank while the terminal is on.**

This is a normal condition when the CRT saver parameter is on. You can turn the CRT saver off in the setup mode. After 15 minutes of inactivity, the display disappears but the data is not lost. Press any key to bring back the display (SHIFT will bring back the display without altering it).

**The screen doesn't respond when you press a key.**

1. If **WAIT** appears in the terminal message line your program has locked the keyboard. To unlock it, press **SETUP** with **SHIFT**.
2. Make sure the keyboard cable connection is good.
3. If **LOCK** appears when you press **LOCK**, check the computer communications setup. See the next condition.

**The computer doesn't respond when you type on the keyboard.**

1. Check the interface cable connections. Is the computer interface cable connected to the COMM port? Does it have the correct connector pin assignments (see Appendix B)?
2. Make sure the status line displays **LINE**. If it does not turn the block mode off by pressing F4. To turn **LOCL** off, you must enter the setup mode, General level one. Also check the COMM port baud rate, data bit, handshake, stop bit, and parity bit selections; they should all match your computer.

**When the terminal is turned on, an X or Y displays in the bottom right-hand corner of the screen.**

Hold down the SETUP key to exit self-test. If the error code continues, turn the terminal off and then on again.

**When the terminal is turned on, 0, 1, 2, 3, P, or Z appears in the bottom right-hand corner of the screen.**

The terminal needs to be serviced by a qualified technician.

**Nonsense characters (garbage) appear on the screen.**

1. Match the COMM port baud rate setup parameter in the setup mode with your computer's baud rate.
2. Check the pin connections of the computer interface cable (see Appendix B).

**Characters become garbled as they appear on the screen.**

Make sure the selection for the stop bit, parity, and data bit setup parameters match the requirements of your computer.

**All characters display double when they should be single.**

Turn off the Echo communication level from the setup mode (see Chapter 2).

**The function, cursor, and/or keypad keys do not work.**

Make sure the selection for data bits and parity match the requirements of your computer. Most systems use 8 data bits, no parity.

# Appendix A—Specifications

<b>Screen</b>	Size: 14 inches measured diagonally. Attributes: P138 green, phosphor.
<b>Display Format</b>	26 lines (one terminal status line, 24 or 25 data display lines, zero or one label line/system message line); 80 or 132 columns (user selectable).
<b>Character Formation</b>	80-column: 7 × 9 matrix, 10 × 10 cell. 132-column: 7 × 9 matrix, 9 × 10 cell.
<b>Character Set</b>	US ASCII
<b>Displayed Character Sets</b>	512 characters (94 displayable ASCII characters, 72 control code symbols, 94 special graphics characters, 94 multinational supplement fonts, 32 graphic characters, 126 soft programmable characters).
<b>Cursor Control</b>	Home, up, down, left, right, tab, and carriage return.
<b>Cursor Attributes</b>	Block/line; blinking/steady; on/off.
<b>Communications</b>	One DB-25 EIA RS-423 (RS-232C compatible) interface; one 20mA passive current loop interface; and one DB-9 auxiliary printer interface.
<b>Operating Modes</b>	Setup, online, and local.
<b>Online Communication Modes</b>	Block, half duplex, and full duplex.
<b>Word Structure</b>	7 or 8 data bits; 1 or 2 stop bits.
<b>Parity</b>	Odd, even, mark, none, or space.
<b>Handshake Protocol</b>	XON/XOFF, DTR, both, or none.
<b>Maximum Baud Rates</b>	COMM Port: 38,400 PR Port: 19,200 20mA Port: 38,400
<b>Video Attributes</b>	Normal, dim, bold, blink, blank, underline and reverse (combinable).
<b>Keyboard</b>	Low-profile detached with 6-foot coiled cable; two-position tilt; 105 keys, including 15 programmable function keys (shifted to 30), and numeric keypad.
<b>Fields</b>	Unprotected only.

***Power Requirements***

115 volts AC, 60 Hz; 230 volts AC, 50 Hz.

***Weight***

Net weight 31 pounds.

***Dimensions***

	<b>Height</b>		<b>Width</b>		<b>Depth</b>	
	<b>in</b>	<b>cm</b>	<b>in</b>	<b>cm</b>	<b>in</b>	<b>cm</b>
Video Module	12	30.48	12.3	31.24	13	33.02
Module Base	1.25	3.20	12.25	31.12	10.25	26.04
Keyboard	2.25	5.72	18.7	47.6	6.9	17.6



# Appendix B—Connector Pin Assignments

*Table B-1 COMM Port Configuration (DTE-Data Terminal Equipment)*

<b>Pin</b>	<b>Signal</b>	<b>Mnemonic</b>	<b>Description</b>
1	Shield Ground	PGND	Ground to which cable should be connected.
2	Transmit Data	TXD	(Output) Transmits serial data characters. Held low during idle. Data is only sent when DSR, CTS, and DCD are high if modem control mode is enabled. Held high for 1/4 second during a break.
3	Receive Data	RXD	(Input) Receives serial data characters.
4	Request to Send	RTS	(Output) Lowered for 2 seconds if the shifted Break key is pressed or if modem control mode is enabled and DCD or DSR is low (60 ms or 2 sec).
5	Clear to Send	CTS	(Input) If modem control mode is enabled, data is sent by the terminal when this line and DCD are high. Ignored otherwise.
6	Data Set Ready	DSR	(Input) If modem control mode is enabled, data is only sent by the terminal when this line, CTS, and DCD are high. Ignored otherwise.
7	Signal Ground	SGND	Common ground reference for all connector signals.

**Table B-1 Continued**

<b>Pin</b>	<b>Signal</b>	<b>Mnemonic</b>	<b>Description</b>
8	Data Carrier Detect (Receive Signal Detect)	DCD or RLSD	(Input) If modem control mode is enabled, data is only sent by the terminal when this line, DSR, and CTS are high. Ignored otherwise.
12	Speed Indicator	SPDI	(Input) If modem control mode is enabled, a high level on this line causes the terminal to transmit and receive data at the 1200 baud regardless of the speed selected in setup.
20	Data Terminal Ready	DTR	(Output) When DTR handshake is enabled, this line is lowered when the terminal is not ready to receive any more data.
23	Speed Select	SPDS	(Output) When modem control mode is enabled, this line is lowered if the terminal's receive speed is less than 1200 baud.

**Table B-2 PR Port Configuration**

<b>Pin</b>	<b>Signal</b>	<b>Mnemonic</b>	<b>Description</b>
1	Shield Ground	PGND	Ground to which cable shield should be connected.
2	Transmit Data	TXD	(Output) Transmits serial data characters. Held low during idle. Data is only sent when DSR is high.
3	Receive Data	RXD	(Input) Receives serial data characters.
4	Request to Send	RTS	(Output) This signal is held high when the terminal is powered on.
5	Data Terminal Ready	DTR	(Output) This signal is lowered in bidirectional print mode if the DTR handshake is enabled and the terminal is not ready to receive data.
6	Data Set Ready	DSR	(Input) When this signal is low, data is not sent out the printer port. If this signal has not been high since terminal power-up or reset, and printer DTR handshake is enabled in setup mode, print commands are ignored.
7	Signal Ground	SGND	Common ground references for all signals.

**Table B-3 20mA Port Pin Assignments**

<b>Pin</b>	<b>Signal</b>
1	- 12 volt
2	Negative transmit
3	Negative receive
5	Positive transmit
7	Positive receive
8	Ground

**Table B-4 Typical Modem Pin Assignments**

<b>Terminal (DTE)</b>	<b>Hayes Smartmodem 1200 (DCE)</b>
1	1
2	2
3	3
7	7
20	20

We recommend that pins 6 and 8 be disconnected, since they are modem protocols that may “lock up” the terminal.

- **Note**—Hayes Smartmodem 1200 (front panel) switch settings should be DUDUDDUD (D=down, U=up).

**Table B-5 Sample Printer Connection**

Signal	9-Pin Male PR Port (DTE)	Printer (DTE)	Signal
Transmit Data	2	→ 3	Receive Data
Receive Data	3	← 2	Transmit Data
Request to Send	4	→ 5	Clear to Send
Clear to Send	5	→ 6 to 8	Data Set Ready to Data Carrier Detect
Data Set Ready	6	← 11	Busy
Signal Ground	7	- - - - - 7	Signal Ground

The pin numbers are

9-Pin Male PR Port

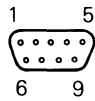

25-Pin Male COMM Port

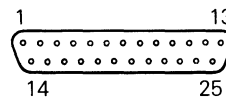

8-Pin Female 20mA Port

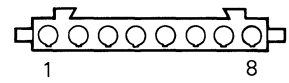



# Appendix C—Recognized Command Sequences

<i>Command</i>	<i>Sequence</i>	<i>Mnemonic</i>
<b>Controlling Functional Modes*</b>		
Lock keyboard	CSI 2 h	KAM
Unlock keyboard	CSI 2 l	KAM
Monitor mode on**	CSI 3 h	CRM
Monitor mode off	CSI 3 l	CRM
Insert mode on	CSI 4 h	IRM
Insert mode off	CSI 4 l	IRM
Local echo off	CSI 12 h	SRM
Local echo on	CSI 12 l	SRM
Control execution off**	CSI 13 h	FEAM
Control execution on	CSI 13 l	FEAM
Transmit through cursor position	CSI 16 h	TTM
Transmit to end of line or end of display	CSI 16 l	TTM
New line mode on	CSI 20 h	LNM
New line mode off	CSI 20 l	LNM
Cursor keys send application-dependent codes	CSI ?1 h	DECCKM
Cursor keys send cursor movement codes	CSI ?1 l	DECCKM
VT52 mode on	CSI ?2 l	DECANM
132-column display	CSI ?3 h	DECCOLM
80-column display	CSI ?3 l	DECCOLM
Smooth scrolling on	CSI ?4 h	DECSCLM
Jump scrolling on	CSI ?4 l	DECSCLM
Reverse screen video on	CSI ?5 h	DECSCNM
Normal screen video on	CSI ?5 l	DECSCNM
Line 1 is top of scrolling region	CSI ?6 h	DECOM
Line 1 is top of display area	CSI ?6 l	DECOM
<u>Autowrap on</u>	CSI ?7 h	DECAWM

\* More than one mode, but less than 17, may be set with one sequence by entering multiple numeric parameters separated by semicolons (;). However, you cannot combine sequences containing the question mark with those that don't contain a question mark. Nor can you combine sequences ending with "h" with those ending in "l".

\*\*To set monitor mode on and control execution off from the keyboard, press CTRL ◀.

<i>Command</i>	<i>Sequence</i>	<i>Mnemonic</i>
<b>Controlling Functional Modes* (continued)</b>		
Autowrap off	CSI ?7 l	DECAWM
Autorepeat on	CSI ?8 h	DECARM
Autorepeat off	CSI ?8 l	DECARM
Block mode on	CSI ?10 h	DECEDM
Block mode off	CSI ?10 l	DECEDM
Unshifted function keys operate locally	CSI ?16 h	DECEKEM
Unshifted function keys operate remotely	CSI ?16 l	DECEKEM
Send FF after print screen operation	CSI ?18 h	DECPFF
No FF sent after print screen operation	CSI ?18 l	DECPFF
Print full screen	CSI ?19 h	DECPEX
Print scrolling region	CSI ?19 l	DECPEX
Display cursor	CSI ?25 h	DECTCEM
Cursor off	CSI ?25 l	DECTCEM
Blank screen	CSI 30 h	WYDSCM
Display screen	CSI 30 l	WYDSCM
Display status line	CSI 31 h	WYSTLINM
Blank status line	CSI 31 l	WYSTLINM
Screen saver	CSI 32 h	WYCRTSAVM
Screen saver off	CSI 32 l	WYCRTSAVM
Cursor steady (nonblinking)	CSI 33 h	WYSTCURM
Cursor blinking	CSI 33 l	WYSTCURM
Underline cursor on	CSI 34 h	WYULCURM
Block cursor on	CSI 34 l	WYULCURM
Don't clear screen after width change	CSI 35 h	WYCLRM
Clear screen after width change	CSI 35 l	WYCLRM
key set to BS/DEL	CSI 36 h	WYDELKM

\*More than one mode, but less than 17, may be set with one sequence by entering multiple numeric parameters separated by semicolons (;). However, you cannot combine sequences containing the question mark with those that don't contain a question mark. Nor can you combine sequences ending with "h" with those ending with "l".



<i>Command</i>	<i>Sequence</i>	<i>Mnemonic</i>
<b>Controlling Functional Modes* (continued)</b>		
ⓧ key set to DEL/CAN	CSI 36 l	WYDELKM
Send erasable and nonerasable characters	CSI 37 h	WYGATM
Send only erasable characters	CSI 37 l	WYGATM
Send full screen	CSI 38 h	WYTEXM
Send scrolling region	CSI 38 l	WYTEXM
Turn 25th line on	CSI 40 h	WYEXTDM
Turn 25th line off	CSI 40 l	WYEXTDM

\*More than one mode, but less than 17, may be set with one sequence by entering multiple numeric parameters separated by semicolons (;). However, you cannot combine sequences containing the question mark with those that don't contain a questions mark. Nor can you combine sequences ending with "h" with those ending with "l".

### Controlling Terminal Compatibility Modes

VT200 8-bit mode on	CSI 62;2 "p	DECSCCL
VT200 7-bit mode on	CSI 62;1 "p	DECSCCL
VT100 mode on	CSI 61 "p	DECSCCL
VT52 mode on	CSI ?2 l	DECANM
8-bit transmission mode on (VT200)	ESC SPACE G	S8C1T
7-bit transmission mode on (VT200)	ESC SPACE F	S7C1T

### Controlling Character Sets

Load soft character font	ESC P <i>f</i> ; <i>n</i> ; <i>e</i> ; <i>ms</i> { <i>abc uc /lc ...ST</i>	DECDDL
<i>f</i>	Soft font	
0	Soft font selected	
2	Soft graphics font selected	

**Controlling Character Sets (continued)**

*n* Indicates initial character position; ASCII character positions are numbered consecutively, beginning with 1 (e.g., to redefine "\$" use "4").

*e* Erase control specified

0 or 2 Erase all characters in set

1 Erase only redefined characters

*ms* Matrix size

0  $7 \times 10$

1  $4 \times 10$

2  $5 \times 10$

3  $6 \times 10$

4  $7 \times 10$

5  $8 \times 10$

{ is a separator

*abc* Font code (fcode)

a U.S. ASCII character from SP to / (optional).

b U.S. ASCII character from SP to / (optional).

c U.S. ASCII character from 0 (zero) to ~ (required).

*uc/lc* Character code

uc U.S. ASCII characters for upper code of character.

/ Required separator

lc U.S. ASCII characters for lower code of character.

Label character set ESC *x fcode* SCS

*x* Label assigned

( G0

) G1

\* G2

+ G3

<i>Command</i>	<i>Sequence</i>	<i>Mnemonic</i>
----------------	-----------------	-----------------

**Controlling Character Sets (continued)**

<i>fcode</i>	Font code		
0	Special graphics		
1	Alternate character		
A	U.K. ASCII		
B	U.S. ASCII		
<	Multinational supplemental		
other	Defined with load soft character font sequence (must match <i>abc</i> field in soft font load to enable soft font)		
Load G0 character set into GL	CTRL O		SO or LS1
Load G1 character set into GL	CTRL N		SI or LS0
Load G1 character set into GR	ESC ~		LS1R
Load G2 character set into GL	ESC n		LS2
Load G2 character set into GR	ESC }		LS2R
Load G3 character set into GL	ESC .		LS3
Load G3 character set into GR	ESC :		LS3R
Shift G2 character set into GL for one character only	ESC N		SS2
Shift G3 character set into GL for one character only	ESC O		SS3

**Controlling Character, Field, and Line Attributes**

Define character attributes*	CSI <i>n m</i>		SGR
<i>n</i>	Character attribute		
0	Normal		
1	Bold		
2	Dim		
4	Underscored		
5	Blink		
7	Reverse video		
8	Concealed		
22	Normal intensity		

\*Attributes may be combined by separating character attribute parameters with semicolons (;).

<i>Command</i>	<i>Sequence</i>	<i>Mnemonic</i>
----------------	-----------------	-----------------

**Controlling Character, Field, and Line Attributes (continued)**

24	Underscore off		
25	Steady (blinking off)		
27	Positive image (reverse off)		
Define erasable character	CSI 0 "q	DECSCA	
	or CSI 2 "q	DECSCA	
Define nonerasable character	CSI 1 "q	DECSCA	
Define top half of double-high, double-wide line	ESC # 3	DECDDL	
Define bottom half of double-high, double-wide line	ESC # 4	DECDDL	
Define single-high, single-wide line	ESC # 5	DECSWL	
Define single-high, double-wide line	ESC # 6	DECDDL	
Define top half of double-high, single-wide line	ESC # :	WYDDL	
Define bottom half of double-high, single-wide line	ESC # ;	WYDDL	

**Controlling the Cursor**

Display cursor	CSI ?25 h	DECTCEM
Cursor off	CSI ?25 l	DECTCEM
Cursor steady (nonblinking)	CSI 33 h	WYSTCURM
Cursor blinking	CSI 33 l	WYSTCURM
Underline cursor on	CSI 34 h	WYULCURM
Block cursor on	CSI 34 l	WYULCURM
Cursor keys send application-dependent codes	CSI ?1 h	DECCKM
Cursor keys send cursor movement codes	CSI ?1 l	DECCKM
Move cursor to <i>n</i> column	CSI <i>n</i> G	CHA
	or CSI <i>n</i> `	HPA
Move cursor up <i>n</i> lines	CSI <i>n</i> A	CUU
Move cursor down <i>n</i> lines	CSI <i>n</i> B	CUD
	or CSI <i>n</i> e	VPR
Move cursor right <i>n</i> columns	CSI <i>n</i> C	CUF
	or CSI <i>n</i> a	HPR

<i>Command</i>	<i>Sequence</i>	<i>Mnemonic</i>
<b>Controlling the Cursor (continued)</b>		
Move cursor left <i>n</i> columns	CSI <i>n</i> D	CUB
Move cursor down <i>n</i> lines to column 1	CSI <i>n</i> E	CNL
Move cursor up <i>n</i> lines to column 1	CSI <i>n</i> F	CPL
Move cursor to line <i>n</i>	CSI <i>n</i> d	VPA
Move cursor to line <i>n1</i> , column <i>n2</i>	CSI <i>n1</i> ; <i>n2</i> H	CUP
	or CSI <i>n1</i> ; <i>n2</i> f	HVP
Move cursor down one line in current column, scroll up if at bottom line	IND	IND
	or ESC D	IND
	or CTRL J	LF
	or CTRL K	VT
	or CTRL L	FF
Move cursor up one line in current column, scroll down if at top line	RI	RI
	or ESC M	RI
Move cursor down one line to column 1	NEL	NEL
	or ESC E	NEL
Save display attributes, cursor position, character sets, wrap flag and origin mode status	ESC 7	DECSC
	or CSI s	WYSC
Restore last saved display attributes, cursor position, character set, wrap flag, and origin mode status	ESC 8	DECR
	or CSI u	WYRC
Backspace cursor	CTRL H	BS
Move cursor to next tab stop	CTRL I	HT
Move cursor to column 1 of current line	CTRL M	CR

<i>Command</i>	<i>Sequence</i>	<i>Mnemonic</i>
<b>Editing Functions</b>		
Erase from cursor to end of display	CSI 0 J	ED
Erase from start of display to cursor	CSI 1 J	ED
Erase entire display	CSI 2 J	ED
Erase from cursor to end of line	CSI 0 K	EL
Erase from start of line to cursor	CSI 1 K	EL
Erase entire line	CSI 2 K	EL
Erase erasable characters from cursor to end of display	CSI ?0 J	DECSED
Erase erasable characters from start of display to cursor	CSI ?1 J	DECSED
Erase erasable characters in entire display	CSI ?2 J	DECSED
Erase erasable characters from cursor to end of line	CSI ?0 K	DECSEL
Erase erasable characters from start of line to cursor	CSI ?1 K	DECSEL
Erase erasable characters from entire line	CSI ?2 K	DECSEL
Erase <i>n</i> characters beginning at cursor	CSI <i>n</i> X	ECH
Insert <i>n</i> blank characters beginning at cursor	CSI <i>n</i> @	ICH
Insert <i>n</i> blank lines beginning at cursor line	CSI <i>n</i> L	IL
Delete <i>n</i> lines beginning at cursor line	CSI <i>n</i> M	DL
Delete <i>n</i> characters beginning at cursor	CSI <i>n</i> P	DCH
<b>Controlling Margins</b>		
Set top/bottom margins	CSI <i>t</i> ; <i>b</i> r	DECSTBM
<p><i>t</i> is the top line number  <i>b</i> (optional) is the bottom line number (if omitted, treated as bottom screen line)</p>		

<i>Command</i>	<i>Sequence</i>	<i>Mnemonic</i>
<b>Controlling Tabs</b>		
Clear tab stop at cursor	CSI 0 g	TBC
	or CSI 2 W	CTC
Clear all tab stops	CSI 3 g	TBC
	or CSI 5 W	CTC
Set tab stop at cursor	CSI 0 W	CTC
	or ESC H	HTS
Set tab stop every 8th column	CSI ?5 W	CTC
Move forward <i>n</i> tab stops	CSI <i>n</i> I	CHT
Move backward <i>n</i> tab stops	CSI <i>n</i> Z	CBT
Move cursor to next tab stop	CTRL I	HT
<b>Controlling Scrolling</b>		
Smooth scrolling on	CSI ?4 h	DECSCLM
Jump scrolling on	CSI ?4 l	DECSCLM
Set 4 lps smooth scrolling speed	CSI 0 z	WYSCRATE
Set 1 lps smooth scrolling speed	CSI 1 z	WYSCRATE
Set 2 lps smooth scrolling speed	CSI 2 z	WYSCRATE
Set 4 lps smooth scrolling speed	CSI 3 z	WYSCRATE
Set 8 lps smooth scrolling speed	CSI 4 z	WYSCRATE
<b>Controlling Function Keys</b>		
Unshifted function keys operate locally	CSI ?16 h	DECEKEM
Unshifted function keys operate remotely	CSI ?16 l	DECEKEM

<i>Command</i>	<i>Sequence</i>	<i>Mnemonic</i>
----------------	-----------------	-----------------

**Controlling Function Keys (continued)**

Program function keys\*                      DCS *c;kl* | *kc/hc* ST    DECUKD

<i>c</i>	Clear		
0	Clear all key definitions		
1	Clear keys only as they are redefined		
<i>kl</i>	Key lock		
0	Lock key definitions		
1	Don't lock key definitions		
<i>kc</i>	Shifted function key	<i>kc</i>	Unshifted function key
17	F6	37	F6
18	F7	38	F7
19	F8	39	F8
20	F9	40	F9
21	F10	41	F10
23	F11	43	F11
24	F12	44	F12
25	F13	45	F13
26	F14	46	F14
28	HELP (F15)	48	HELP (F15)
29	DO (F16)	49	DO (F16)
31	F17	51	F17
32	F18	52	F18
33	F19	53	F19
34	F20	54	F20
<i>hc</i>	Hexadecimal representation of character string assigned to the function key.		

\*Multiple function key definitions can be programmed by entering the <*kc*>/<*hc*> parameters for each, separated by semicolons (;).



<i>Command</i>	<i>Sequence</i>	<i>Mnemonic</i>
----------------	-----------------	-----------------

**Controlling Function Keys (continued)**

Report function key redefinition string

<i>n</i>	Shifted function key	CSI < <i>n</i>	Unshifted function key	WYFKEX
a	F6	A	F6	
b	F7	B	F7	
c	F8	C	F8	
d	F9	D	F9	
e	F10	E	F10	
f	F11	F	F11	
g	F12	G	F12	
h	F13	H	F13	
i	F14	I	F14	
j	HELP (F15)	J	HELP (F15)	
k	DO (F16)	K	DO (F16)	
l	F17	L	F17	
m	F18	M	F18	
n	F19	N	F19	
o	F20	O	F20	

**Auxiliary Keypad Modes**

Auxiliary keypad numeric mode on	ESC >	DECKPNM
Auxiliary keypad applic. mode on	ESC =	DECKPAM

**Transmission/Printer Control**

Transmit through cursor position	CSI 16 h	TTM
Transmit to end of line or end of display	CSI 16 l	TTM
Send FF after print screen operation	CSI ?18 h	DECCPFF
No FF sent after print screen operation	CSI ?18 l	DECCPFF
Print full screen	CSI ?19 h	DECPEX
Print scrolling region	CSI ?19 l	DECPEX

<i>Command</i>	<i>Sequence</i>	<i>Mnemonic</i>
<b>Transmission/Printer Control (continued)</b>		
Send erasable and nonerasable characters	CSI 37 h	WYGATM
Send only erasable characters	CSI 37 l	WYGATM
Send full screen	CSI 38 h	WYTEXM
Send scrolling region	CSI 38 l	WYTEXM
8-bit transmission mode on (VT200)	ESC SPACE G	S8CIT
7-bit transmission mode on (VT200)	ESC SPACE F	S7CIT
Print screen	CSI 0 i	MC
Send screen	CSI 2 i	MC
Transparent print mode off	CSI 4 i	MC
Transparent print mode on	CSI 5 i	MC
PR port receive mode off	CSI 6 i	MC
PR port receive mode on	CSI 7 i	MC
Print line	CSI ?1 i	MC
Send line	CSI ?3 i	MC
Copy print mode off	CSI ?4 i	MC
Copy print mode on	CSI ?5 i	MC
Transmit FF after send screen operation	CSI 1	DECTTC
No FF after send screen operation	CSI 0	DECTTC
Send character at cursor	ESC 5	WYXCH
Send answerback message	CTRL E	ENQ
Suspend transmission	CTRL S	DC3
Resume transmission	CTRL Q	DC1
<b>More Terminal Control Commands</b>		
Delay processing about 250 ms	ESC ,	WYDELAY
Display screen adjustment pattern	ESC # 8	DECALN
Sound bell, if enabled	BEL (CTRL G)	
Abort escape sequence; no character displayed	CAN (CTRL X)	

<i>Command</i>	<i>Sequence</i>	<i>Mnemonic</i>
----------------	-----------------	-----------------

**More Terminal Control Commands (continued)**

Abort escape sequence; display reverse question mark	SUB (CTRL Z)	
Initiate escape sequence	ESC (CTRL [])	

**Terminal Resets**

Soft terminal reset	CSI ! p	DECSTR
Hard terminal reset	ESC c	RIS
Terminal mode reset	ESC ! p	WYSTR

**Controlling L1–L4 Status Line Labels**

Suppress L1–L4 labels	CSI 0 q	DECLL
Display L1 label*	CSI 1 q	DECLL
Display L2 label*	CSI 2 q	DECLL
Display L3 label*	CSI 3 q	DECLL
Display L4 label*	CSI 4 q	DECLL

\*These commands may be combined in one string by separating the numeric parameters with semicolons (;).

**Terminal Status Reports**

<b>Request:</b> Identify product type (VT100 mode only)	ESC SPACE	WYID
<b>Response:</b> Terminal	85 CR	
<b>Request:</b> Report primary attributes	CSI 0 c or ESC Z	DA DECID
<b>Response:</b> VT100 mode VT200 mode	CSI ?1;2c CSI ?62;1;2;6;7;8c	

<i>Command</i>	<i>Sequence</i>	<i>Mnemonic</i>
<b>Terminal Status Reports (continued)</b>		
<b>Request:</b> Report secondary attributes	CSI >0 c	DA
<b>Response:</b> Current revision	CSI >1;rev;0c	
<b>Request:</b> Report terminal status	CSI 5 n	DSR
<b>Response:</b> Terminal functioning and ready	CSI 0 n	
<b>Request:</b> Report cursor position	CSI 6 n	DSR
<b>Response:</b> Cursor at line <i>l</i> , column <i>c</i>	CSI <i>l</i> ; <i>c</i> r	
<b>Request:</b> Report printer status	CSI ?15 n	DSR
<b>Response:</b> Printer ready	CSI ?10 n	
Printer not ready	CSI ?11 n	
Printer not connected	CSI ?13 n	
<b>Request:</b> Report function key status	CSI ?25 n	DSR
<b>Response:</b> Key definitions not locked	CSI ?20 n	
Key definitions locked	CSI ?21 n	
<b>VT52 Mode Escape Sequences</b>		
Move cursor up one line	ESC A	
Move cursor down one line	ESC B	
Move cursor right one column	ESC C	
Move cursor left one column	ESC D	
Move cursor to home position	ESC H	
Move cursor up one line with scroll	ESC I	

**Command****Sequence**

---

**VT52 Mode Escape Sequences (continued)**

Move cursor to line <i>l</i> column <i>c</i>	ESC Y <i>l c</i>
Select graphics character set	ESC F
Select U.S. ASCII character set	ESC G
Erase from cursor to end of display	ESC J
Erase from cursor to end of line	ESC K
Print cursor line	ESC V
Print display	ESC J
Transparent print mode on	ESC W
Transparent print mode off	ESC X
Copy print mode on	ESC ^
Copy print mode off	ESC _
Keypad application mode on	ESC =
Keypad application mode off	ESC >
Enter VT100 mode	ESC <
<b>Request:</b> Identify terminal	ESC Z
<b>Response:</b> VT52	ESC / Z



# Index

## A

Adjustments  
  brightness, 1-10  
  keyboard, 1-10  
  terminal, 1-10  
Answerback message, 2-22, 2-24  
ASCII, 2-20  
Auto print mode, 2-20  
Autowrap mode, 2-8

## B

Background of screen, 2-9  
Baud rate  
  COMM port, 2-14, 4-4  
  printer, 2-18  
Beep, 1-9, 4-2  
Bell  
  how to set, 2-21  
Bit modes  
  eight-bit, 2-15  
  seven-bit, 2-15  
Blank screen, 2-9  
Block mode, 3-13  
BREAK key, 2-22, 2-24  
Brightness  
  adjusting screen, 1-10, 4-3

## C

Cables  
  installing, 1-2  
CAPS key, 2-21  
Carriage return, 2-11  
Changing baud rates, 2-14, 2-18  
Character  
  displayed sets, A-1  
  echo, 4-4  
  graphics, 3-10  
Clearing tabs, 2-25  
Clearing the screen, 2-10  
COMM port, 1-6  
  baud rate, 2-14, 4-4  
  data bits, 2-15

Communication  
  with computer, 2-14  
  with printer, 2-18  
Communication modes  
  block, 3-13  
  full-duplex, 3-13  
  half-duplex, 3-12  
Compatibility  
  VT200, 2-10  
  VT52/VT100, 2-10  
COMPOSE CHARACTER key, 3-3  
Compose characters  
  creating, 3-10  
  European, 3-10  
Computer  
  baud rate, 2-14  
  communications configuration, 4-4  
  connecting terminal, 1-3  
  messages, 1-9  
  sending data to, 2-14, 2-23  
Configuring the terminal, 2-2  
Connecting cables, 1-2  
Connector pin assignments, B-1, 4-4  
  for cables, 1-6  
Control codes, C-1  
Control mode  
  see Monitor mode  
Conversational mode, 2-12  
CRT saver, 2-9  
CTRL key, 3-3  
Current loop, 1-6  
Cursor  
  absence of, 2-2, 4-3  
  attribute settings, 2-9  
  autowrap setting, 2-8  
  blinking, 2-4  
  control keys, 2-6, 2-12  
  home position, 3-9  
  style, 2-9  
Cursor keys, 2-12, 3-5

## D

Damage from shipping, 1-2

Data  
  loss of, 2-14, 2-16  
Data bits  
  computer, 2-15  
  printer, 2-18  
Data terminal ready, 2-18  
Default values of terminal, 2-4  
Delete key, 2-22, 3-4  
Deleting a character, 2-22, 3-4  
Directory  
  for setup mode, 2-4  
Display  
  attributes, 2-9  
  background, 2-9  
  brightness, 1-10  
  parameters, 2-8  
  setup level, 2-8  
DO key, 3-9

**E**  
Echo, 2-15, 3-11, 4-4  
Editing keys, 3-5  
Eight-bit operation, 2-15  
ENTER key, 2-6  
Error codes, 1-9, 4-4

**F**  
Factory default values, 2-4  
Factory test, 2-13  
Fields in setup, 2-3  
FIND key, 3-5  
Full-duplex mode, 3-13  
Function keys, 2-4, 2-23, 2-25, 2-27, 3-7  
  defining, 2-11  
  how to program, 2-25  
Fuse, 4-2

**G**  
Garbage, 4-4  
  on screen, 4-4  
Graphics character set, 3-10

**H**  
Half-duplex mode, 3-12  
Handshaking, 2-16, 2-19  
HELP key, 3-9  
Home position, 3-6, 3-9

**I**  
INSERT HERE key, 3-5  
Installation requirements  
  proper location, 1-2  
  ventilation, 1-2  
  voltage, 1-4  
Installing  
  cables, 1-2  
  keyboard, 1-3  
  modem, 1-7  
  printer, 1-8  
Intensity  
  adjusting display brightness, 1-10  
Interface cables, 1-2

**J**  
Jump scrolling, 2-8

**K**  
Key  
  BREAK, 2-22, 2-24  
  CAPS, 2-21  
  COMPOSE CHARACTER, 3-3  
  CTRL, 3-3  
  Cursor, 2-12, 3-5  
  Delete, 2-22, 3-4  
  DO, 3-9  
  ENTER, 2-6  
  FIND, 3-5  
  Function, 2-4, 2-23, 2-25, 3-7  
  HELP, 3-9  
  INSERT HERE, 3-5  
  LOCK, 3-3  
  NEXT SCREEN, 3-5  
  PF, 3-7  
  PREV SCREEN, 3-6  
  REMOVE, 2-24, 3-6



**Key (continued)**

- RETURN, 2-11, 3-4
- SELECT, 3-6
- SETUP, 2-2, 2-6
- SHIFT, 2-21, 3-4
- TAB, 3-4

**Key repeat, 2-21**

**Keyboard, 3-10**

- adjusting, 1-10
- attaching to terminal, 1-3
- cable, 1-2
- description, 3-2
- numeric keypad, 2-12, 3-2
- unlock, 4-3

**Keyclick option**

- initiating, 3-10

**Keypad**

- main, 3-2, 3-3
- numeric, 2-12, 3-2

**L**

**Linefeed, 2-11**

**Local mode, 2-12, 3-13**

**LOCK key, 3-3**

**Locked keyboard, 4-3**

**M**

**Message line, 1-9**

**Modem**

- baud rate, 2-14
- connecting to terminal, 1-7

**Modes**

- block, 3-13
- full-duplex, 3-13
- half-duplex, 3-12

**Monitor mode**

- description, 3-11
- entering, 3-11

**N**

**NEXT SCREEN key, 3-5**

**Numeric keypad, 2-12**

- description, 3-2

**O**

**On/Off switch, 1-9**

**Online operating mode, 3-11**

**Operating modes**

- local, 3-13
- online, 3-11
- setup, 2-2, 3-11

**P**

**Parameters, 2-5**

**Parity, 2-15**

- computer, 2-17
- printer, 2-18

**Password**

- answerback setup level, 2-24

**PF keys, 3-7**

**Pin assignments, 4-4**

**Pin connections**

- computer, B-1
- printer, B-5

**Port**

- 20mA, 1-6, B-4
- COMM, 1-6, B-1
- data, 2-17
- PR, 1-8, B-3
- RS-232C, 2-17

**Power switch, 1-9**

**Power-on values, 2-4**

**PR Port, 1-8, B-3**

**PREV SCREEN key, 3-6**

**Print**

- data, 2-20
- region, 2-20
- screen, 2-13, 2-20

**Printer**

- auto print mode, 2-20
- baud rate, 2-18
- connecting to terminal, 1-8
- data bits, 2-18
- pin connections, 1-8
- print region, 2-20
- receive, 2-20
- setting baud rate, 2-18

Printer (continued)  
  setting parity, 2-18  
  setting stop bits, 2-19  
Programming function keys, 2-25  
Programs  
  for VT200, 2-10  
  for VT52/VT100, 2-10  
Protocols  
  handshaking, 2-16, 2-19

**R**  
REMOVE key, 2-24, 3-6  
Repeating mode, 2-21  
Resetting terminal, 1-9, 3-3, 3-4  
RETURN key, 2-11, 3-4  
RS-232C cable, 1-5

**S**  
Saver parameter, 2-9  
Saving parameters, 2-7  
Screen  
  background, 2-9  
  brightness, 4-3  
  nonsense characters, 4-4  
  saver parameter, 4-3  
  width, 2-10  
Screen saver, 2-9  
Scroll speed  
  scrolling rate, 2-8, 3-10  
SELECT key, 3-6  
Self-Test  
  factory diagnostic, 2-13  
  passing, 1-9  
  terminal, 1-9  
  when terminal finds error, 1-9  
Sending data  
  to computer, 2-13, 2-17, 2-23  
  to printer, 2-19  
Setting screen width, 2-8  
Setting tabs, 2-24  
Setting up the terminal  
  computer, 1-3, 2-14

Setting up the terminal (continued)  
  interface cables, 1-2  
  introduction, 2-2  
  modem, 1-7  
  power cord, 1-2  
  printer, 1-8, 2-18  
  proper location, 1-2  
  ventilation, 1-2  
  voltage, 1-4  
SETUP key, 2-2, 2-6  
Setup mode  
  active field, 2-3  
  changing values, 2-4  
  description, 2-2  
  directory, 2-5  
  display parameters, 2-8  
  entering, 2-2, 2-6  
  exiting, 2-27  
  levels of, 2-4  
  VT200, 2-10  
  VT52/VT100, 2-10  
Seven-bit operation, 2-15  
SHIFT key, 2-21, 3-4  
Smooth scroll, 2-8  
Space bar, 3-4  
Special characters  
  see Compose characters  
Status line  
  description, 1-9  
  turning on/off, 2-10  
Status messages, 1-9  
Stop bit, 4-4  
  computer, 2-17  
  printer, 2-19  
Style of cursor, 2-9

**T**  
TAB key, 3-4  
Tabs  
  clearing, 2-25  
  default stops, 2-24  
  setting, 2-24  
  setup level, 2-24

Telephone  
  see Modem

Terminal  
  adjustments, 1-10  
  answerback message, 2-22  
  attaching keyboard, 1-3  
  COMM port, 1-6  
  components, 1-2  
  connecting a printer, 1-8  
  connecting to computer, 1-3  
  default values, 2-4  
  installing, 1-2  
  interface cables, 1-2  
  power cord, 1-2  
  PR port, 1-8  
  proper location of, 1-2  
  resetting, 1-9, 3-3, 3-4  
  self-test, 1-9  
  service, 4-4  
  setup mode, 2-2  
  status line, 2-10  
  status messages, 1-9  
  turning on, 1-9  
  unpacking, 1-2  
  ventilation requirements, 1-2  
  voltage requirements, 1-4

Thumbwheel control, 1-10

Transparent print, 2-20

Troubleshooting  
  absence of cursor, 4-3  
  blank screen, 4-3  
  garbage on screen, 4-4  
  keyboard locked, 4-3  
  no beep, 4-2  
  replacing fuse, 4-2

Turning on terminal, 1-9

**V**

Ventilation requirements, 1-2

Video attributes, 2-9

Voltage requirements, 1-4

VT200  
  setup, 2-10

VT52/VT100  
  setup, 2-10

**W**

Warning bell, 2-22

Width of screen, 2-8

Wraparound cursor, 2-8

**X**

XON/XOFF handshaking, 2-16



***FCC Notice***

This equipment generates, uses, and can radiate radio frequency energy, and if not installed and used in accordance with the instruction manual, may cause interference to radio communications. It has been tested and found to comply with the limits for a Class A computing device pursuant to Subpart J of Part 15 of FCC Rules, which are designed to provide reasonable protection against such interference when operated in a commercial environment. Operation of this equipment in a residential area is likely to cause interference, in which case the user, at his own expense, will be required to take whatever measures may be required to correct the interference. If this equipment does cause interference to radio or television reception, which can be determined by turning the equipment off and on, try to correct the interference by one or more of the following measures:

- Reorient the receiving antenna
- Relocate the terminal in relation to the receiver
- Plug the terminal into a different outlet so that terminal and receiver are on different branch circuits.

88-060-01 Rev. B  
May 1985  
Printed in U.S.A.

Wyse Technology  
3571 N. First Street  
San Jose, CA 95134

**WYSE**  
■ ■ ■ ■