

# TAITO

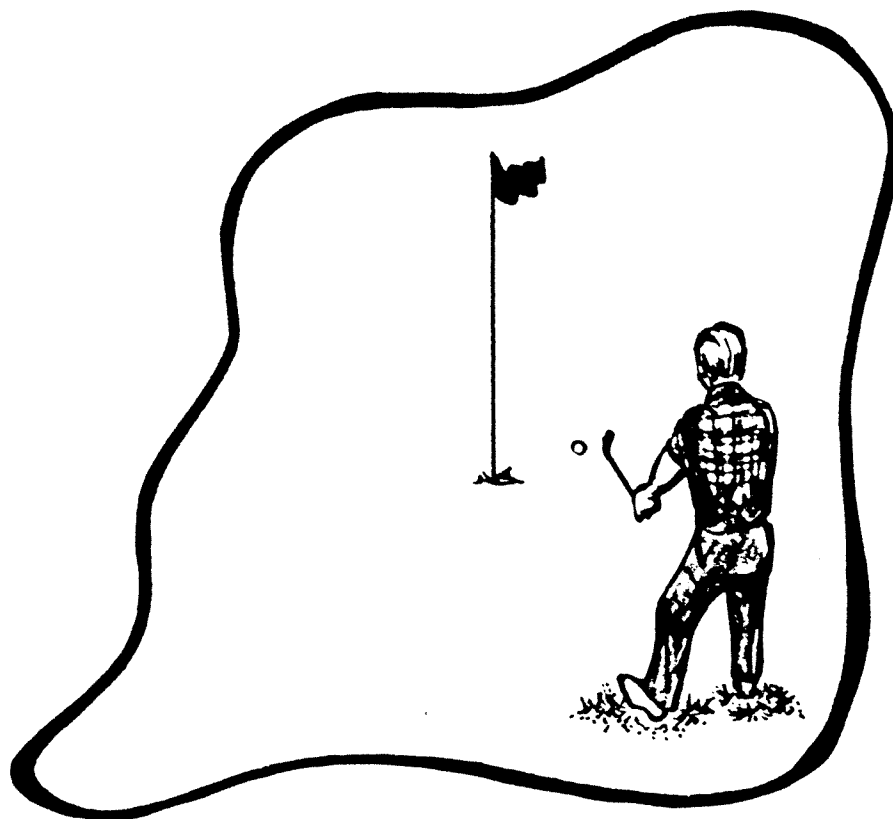

## OPERATING MANUAL



# TAITO

TAITO AMERICA CORPORATION  
660 S. Wheeling Road  
Wheeling, IL 60090  
Telephone (312) 520-9280  
Fax (312) 520-1309

T A B L E O F C O N T E N T S

	Page Numbers
GAME DESCRIPTION & INSTRUCTIONS .....	2
GENERAL INFORMATION & PARTS LISTING.....	3 - 5
GAME PREPARATION & CONVERSION INSTRUCTIONS .....	6 - 7
OPTION DIP-SWITCH SETTINGS .....	8 - 9
WIRING DIAGRAMS .....	9 - 10
CONTROL PANEL LAYOUT .....	11

## GAME INSTRUCTIONS

### GAME DESCRIPTION:

U.S. CLASSIC is a vertical video game and may be played by one or two players alternately. After inserting the proper coinage and starting a one or two player game, the screen displays the conditions for the first hole. This would include the wind velocity, yardage and direction of the green. The screen also displays a complete set of clubs, from the putter and pitching wedge to the 1 wood. The screen points to a suggested club based on wind conditions, terrain and distance which affect each shot. If the player agrees with the suggestion, he simply presses the SELECT button. If the player prefers a different club he may select one by simply rolling the track-ball left or right until the pointer rests on the club he wants. He then presses the SELECT button to enter his choice.

After the club choice is made, the screen displays the player's position on the course together with the distance in yards and wind direction and velocity. Displayed at the right margin of the screen is a complete map of the course showing the player's location and direction to the green. Also displayed is the hole number and whether that particular hole is IN or OUT. The first 9 holes are IN and the last 9 holes are OUT. A 9 hole course is always played on the OUT or last 9 holes.

As the player tees off, his concern is with wind direction, wind velocity and location of the green. In which direction and with how much force to roll the track-ball is dependant on these important factors.

### HOW TO PLAY:

- \* USE BALL CONTROL TO SELECT "9 HOLE" OR "NORMAL."
- \* FOR EACH HOLE UNDER PAR, ONE ADDITIONAL HOLE IS AWARDED.
- \* FOR EACH "HOLE IN ONE", TWO ADDITIONAL HOLES ARE AWARDED.
- \* IF SCORE ON HOLE IS DOUBLE PAR, A "GIVE UP" DISPLAY FLASHES.
- \* PLAYER MAY CONTINUE GAME WHILE THE CONTINUE OPTION IS DISPLAYED.
- \* CLUB SELECTION - Use Ball Control To Select Club.  
Press Select Button To Enter Selection.

W1 - 248 YARDS	14 - 194 YARDS	19 - 128 YARDS
W3 - 235 YARDS	15 - 183 YARDS	PW - 117 YARDS
W4 - 216 YARDS	16 - 172 YARDS	SW - 85 YARDS
W5 - 205 YARDS	17 - 156 YARDS	
13 - 205 YARDS	18 - 139 YARDS	

This manual will guide you in the conversion of your color monitor upright video game into a "U.S. CLASSIC" game. We strongly urge you to read through the instructions carefully before beginning the conversion.

#### WARNINGS AND NOTICES

For safety and reliability, Taito America Corporation does not recommend nor authorize any substitute parts or modifications of Taito America Corporation equipment. In addition, any substitute parts or equipment modifications may void FCC compliance.

Use of non-Taito America parts and/or modifications of game circuitry may adversely affect game performance and safety.

Since "U.S. CLASSIC" is protected by Federal copyright, trademark and patent laws, unauthorized altered versions of this game are illegal under Federal Law. This also applies to unauthorized facsimiles of Taito America equipment, logos, designs, publications, assemblies and/or games (or features not deemed to be in the public domain) whether manufactured with Taito America components or not.

#### NOTICE

Certain parts salvaged from your old game are required to complete your kit. These salvaged parts MUST operate properly to insure the performance and safety level of this game. Always repair circuit board malfunctions and cabinet damage before conversion is attempted.

Check the parts supplied in this kit against the parts list included in this manual.

---

#### CAUTION

FOR SAFE OPERATION IT IS STRONGLY RECOMMENDED THE CABINET BE PROPERLY GROUNDED. THIS GAME IS EQUIPPED WITH A THREE CONDUCTOR POWER CABLE. THE THIRD PRONG (round in shape) WILL AUTOMATICALLY GROUND THE GAME WHEN PLUGGED INTO A PROPERLY GROUNDED THREE PRONG RECEPTICAL. IF IT BECOMES NECESSARY TO USE AN ADAPTOR, THE GROUNDING LUG OR WIRE ON THE ADAPTOR MUST BE PROPERLY GROUNDED TO ASSURE SAFE OPERATION.

---

#### NOTICE

This kit is not intended for use with X-Y monitors. Suitable monitors are the horizontal or vertical raster-scan with inputs for red, green and blue video as well as composite negative sync. (These should be compatible with TTL logic levels.)

Note: "U.S. CLASSIC" USES A COLOR MONITOR IN THE VERTICAL POSITION.

## NOTICE

Be sure the power supply from your old game is capable of +5 vdc regulated at 7A and +12vdc regulated at 2A. These operating voltages are necessary for your kit. Please note the enclosed warning with the PC Board Assembly.

### TAITO AMERICA CORPORATION KIT PARTS PROVIDED

QTY.	DESCRIPTION	REF NO.	PART NO.
1	MARQUEE WITH ARTWORK (STYRENE)		145-108001
1	MONITOR BEZEL		145-208002
1	CONTROL PANEL OVERLAY		145-908004
1	TRACK-BALL MOUNTING PLATE		145-201037
1	TRACK-BALL ASSEMBLY (3 INCH WHITE)		145-201015
2	BUTTONS (WHITE ULTIMATE)	53010011	145-901012
1	BUTTON (YELLOW ULTIMATE)	53010015	145-901033
1	SET OF BUTTON LABELS (3 PCS.)		145-901016
1	WIRING HARNESS (STANDARD JAMMA TYPE)		145-205002
1	ADHESIVE GAME INSTRUCTIONS		145-208005
1	"U.S. CLASSIC" MAIN LOGIC PCB		145-998000
1	OPERATING MANUAL		145-908007
1	R.F. CAGE FOR F.C.C. COMPLIANCE		145-908013
1	PACKING CARTON		145-299002

### TOOLS AND SUPPLIES REQUIRED

- |  |  |
|--|--|
| <ul style="list-style-type: none"> <li><input type="checkbox"/> Screwdriver</li> <li><input type="checkbox"/> Pliers</li> <li><input type="checkbox"/> Hex Driver</li> <li><input type="checkbox"/> Grease Pencil Or Marker</li> <li><input type="checkbox"/> Soldering Iron And Solder</li> <li><input type="checkbox"/> Hacksaw, Jigsaw Or Tablesaw With Carbide-Tipped Blade</li> </ul> | <ul style="list-style-type: none"> <li><input type="checkbox"/> Phillips Screwdriver</li> <li><input type="checkbox"/> Wire Cutters</li> <li><input type="checkbox"/> X-Acto Knife</li> <li><input type="checkbox"/> Electric Drill w/Bits</li> <li><input type="checkbox"/> 180-Grit Sandpaper</li> <li><input type="checkbox"/> Electrical Tape Or Heat-Shrink Tubing</li> </ul> |
|--|--|

\* \* \* TABLE GAME KIT ONLY \* \* \*

TAITO AMERICA CORPORATION KIT PARTS PROVIDED

QTY.	DESCRIPTION	REF NO.	PART NO.
1	MONITOR BEZEL		145-208002
2	CONTROL PANEL OVERLAYS		145-908004
2	TRACK-BALL MOUNTING PLATES		145-201037
2	TRACK-BALL ASSEMBLIES (3 INCH WHITE)		145-201015
2	BUTTONS (WHITE ULTIMATE)	53010011	145-901012
2	BUTTONS (YELLOW ULTIMATE)	53010015	145-901033
1	SET OF BUTTON LABELS (4 PCS.)		145-901016
1	WIRING HARNESS (STANDARD JAMMA TYPE)		145-205002
1	ADHESIVE GAME INSTRUCTIONS		145-208005
1	"U.S. CLASSIC" MAIN LOGIC PCB		145-998000
1	OPERATING MANUAL		145-908007
1	R.F. CAGE FOR F.C.C. COMPLIANCE		145-908013
1	PACKING CARTON		145-299002

All games require a certain amount of maintenance to remain in good operating condition. A periodic check of mechanical controls would be beneficial to guarantee your game will be profitable.

### GAME PREPARATION

#### CLEANING

The exterior of the game, all metal parts and all plastic parts can be cleaned with non-abrasive cleaner. Caution should be used when cleaning the plastic. A dry cloth can cause scratches and result in a foggy worn appearance. Plexiglas cleaner on a soft cloth is suggested to maintain and keep your monitor crt cover looking new.

Inspect your cabinet for any gouges or items stuck on the cabinet like chewing gum. Remove all foreign objects and fill in the gouges with any type of quick hardening wood putty. Sand to ensure the surface is smooth. Wipe the outside of the old cabinet clean. Remember the reason you are converting your old game is to have the increased earnings of a new game. Making your game look like a new game will spark new player-interest.

#### NOTICE

Please make sure you clean the coin mechanisms. It is important that you service them in order for this game to achieve the maximum possible earnings.

#### CONVERSION INSTRUCTIONS

Remove the new "U.S. CLASSIC" Marquee (UPRIGHT GAME KIT ONLY) from the kit. This new Marquee provided with your kit is specifically designed for ease of handling. Place and center the old Marquee on top of the new Marquee. Place masking tape on the area where you intend to cut the new Marquee. Using an X-Acto knife, score the new Marquee and simply break at this score. If your old Marquee is made of glass, remove the paint of the old Marquee and attach the new Marquee behind this glass. If your old Marquee is made of Plexiglas, it is recommended that new clear Plexiglas be used to best provide the brilliance of your new Marquee.

Remove the new "U.S. CLASSIC" monitor bezel from the kit. Place the bezel around the existing monitor. Using an X-Acto knife trim the new monitor bezel to neatly fit around the monitor.

#### CONTROL PANEL

Remove the old control panel lexan decal, buttons and joysticks. Refer to the template provided in this kit to design the best possible positioning for your track-ball(s), buttons and control panel instructions.

Leave your 1 and 2 player start buttons where they are on the old control panel. (Use the enclosed 1 and 2 player button labels if needed.) Drill holes as needed for installation of the track-ball and other buttons. Clean any burrs from around holes. Any hole that is no longer needed we suggest plugging with wood putty or epoxy.

NOTE: A metal plate has been provided for mounting the track-ball to your existing control panel. Use this plate as a template to mark the mounting holes, cut-out, etc. See illustration on page 11.

Cut the new "U.S. CLASSIC" lexan to the appropriate size needed to cover the panel. Leave enough lexan to wrap a small lip around the top and bottom of the panel.

Remove the backing from the "U.S. CLASSIC" lexan and apply it over the old control panel being careful to avoid air pockets.

After the lexan is securely applied, cut the holes on the control panel with an X-Acto knife or razor blade. Install the new track-ball, buttons and button labels and any hardware that might have been removed on the control panel and tighten them down.

## WIRING PROCEDURES

### INSTALLING INTERBOARD WIRING

This game comes with a color-coded cable for easy installation. Refer to the wiring diagram included in this manual for quick connections.

Disconnect the old wiring harness from the old cpu board and carefully remove old circuit boards and FCC cages from the game.

Using the diagrams from your old game, carefully note the function of each wire.

Leaving several inches of wire from the old wiring harness at each connector, cut the wires near the game's coin door, monitor, control panel, power supply and speaker wires. Install the new wiring harness to those points following your wiring diagram. Use electrical tape or heat-shrink tubing to insulate all splices.

Install your FCC cage where the old board set was.

Mount the "U.S. CLASSIC" PCB assembly with the mounting blocks provided in the center of the FCC cage. Plug the wiring harness onto the PCB and close the cage securely. The board cage in this kit must be properly installed and terminated to ground.

Check and clean the input jack on the power supply board. Replace any burned or damaged pins.



## DIP SWITCH SETTINGS

The following option switch settings were designed to allow the customizing of U.S. CLASSIC's various game features to suit different environments. If used wisely, the flexibility they offer can maximize game performance and increase potential earnings.

### DIP SWITCH A

FUNCTION	SETTING	1	2	3	4	5	6	7	8
GAME STYLE	TABLE UPRIGHT	OFF ON							
SCREEN INVERSION	NORMAL INVERTED		OFF ON						
TEST MODE	*NORMAL TEST			OFF ON					
ADJUSTMENT FOR FLYING DISTANCE (Y = YARDS)	*NORMAL RATE NORM. - 30Y NORM. + 10Y NORM. + 20Y NORM. + 30Y NORM. + 40Y NORM. + 50Y NORM. + 60Y				OFF ON OFF ON OFF ON OFF ON	OFF OFF ON ON OFF OFF ON ON	OFF OFF OFF ON ON ON ON		
NOT USED	MUST REMAIN IN "OFF" POSITION							OFF	OFF

\* = FACTORY RECOMMENDED SETTINGS

**CABINET STYLE** - ADJUST THIS SWITCH TO CORRESPOND WITH THE CABINET STYLE BEING CONVERTED.

**SCREEN INVERSION** - THIS SWITCH ALLOWS YOU TO INVERT THE IMAGE ON THE SCREEN, WITHOUT HAVING TO REMOUNT YOUR COLOR MONITOR.

### CLEARING THE BACK-UP RAM

TURN THE POWER TO THE GAME OFF. WITH BOTH THE 1 PLAYER AND 2 PLAYER START BUTTONS DEPRESSED, TURN THE POWER BACK ON. "BKUPRAM CLEARED" WILL BE DISPLAYED. ALL NAMES AND HIGH SCORES WILL RETURN TO THEIR DEFAULT SETTINGS.

DIP SWITCH SETTINGS (cont.)

**DIP SWITCH B**

FUNCTION	SETTING	1	2	3	4	5	6	7	8
GUARANTEED 9 HOLES	2 COINS *3 COINS	OFF ON							
COINAGE	*DOMESTIC FOREIGN		OFF ON						
NUMBER OF GUARANTEED HOLES PER PLAY	*3 HOLES 2 HOLES 1 HOLE 4 HOLES			OFF ON OFF ON	OFF OFF ON ON				
PLAY PRICING COIN A	*1 CO = 1 PL 1 CO = 2 PL 2 CO = 1 PL 2 CO = 3 PL					OFF ON OFF ON	OFF OFF ON ON		
PLAY PRICING COIN B	*1 CO = 1 PL 1 CO = 2 PL 2 CO = 1 PL 2 CO = 3 PL							OFF ON OFF ON	OFF OFF ON ON

\* = FACTORY RECOMMENDED SETTINGS

WIRING DIAGRAM FOR TRACK-BALL HARNESS ASSEMBLY

PIN	COLOR	FUNCTION
1	RED	+5VDC
2	GRN	UP
3	YLW	DOWN
4	BRN	RIGHT
5	ORG	LEFT
6	BLK	GND

**WIRING DIAGRAM FOR "U.S. CLASSIC" KIT HARNESS ASSEMBLY**

**SOLDER SIDE**

**COMPONENT SIDE**

GND	BLK	A	1	BLK	GND
GND	BLK	B	2	BLK	GND
+5VDC	RED	C	3	RED	+5VDC
+5VDC	RED	D	4	RED	+5VDC
	BRN	E	5	BRN	
+12VDC	BLU	F	6	BLU	+12VDC
KEY		H	7		KEY
COIN METER B	WHT/VIO	J	8	BLU/BRN	COIN METER A
COIN LOCKOUT B		K	9		COIN LOCKOUT A
SPEAKER (-)	BLK	L	10	WHT/BLK	SPEAKER (+)
		M	11		
VIDEO GREEN	GRN	N	12	RED	VIDEO RED
VIDEO SYNC	WHT	P	13	BLU	VIDEO BLUE
SERVICE SW.	BRN/WHT	R	14	BLK	VIDEO GND
TILT SW.	WHT/BRN	S	15	YEL	
COIN B	GRN/YEL	T	16	WHT/YEL	COIN A
2PL START	RED/BLK	U	17	PNK/BLK	1PL START
2PL UP	BRN/BLU	V	18	ORG/BLU	1PL UP
2PL DOWN	ORG/WHT	W	19	GRN/ORG	1PL DOWN
2PL LEFT	ORG/GRN	X	20	GRN/BLU	1PL LEFT
2PL RIGHT	WHT/ORG	Y	21	RED/YEL	1PL RIGHT
2PL SELECT	BRN/BLK	Z	22	RED/WHT	1PL SELECT
NOT USED	YEL/WHT	a	23	WHT/RED	NOT USED
NOT USED	BRN/GRN	b	24	YEL/BLK	NOT USED
		c	25		
		d	26		
GND	BLK	e	27	BLK	GND
GND	BLK	f	28	BLK	GND

# SUGGESTED CONTROL PANEL LAYOUT

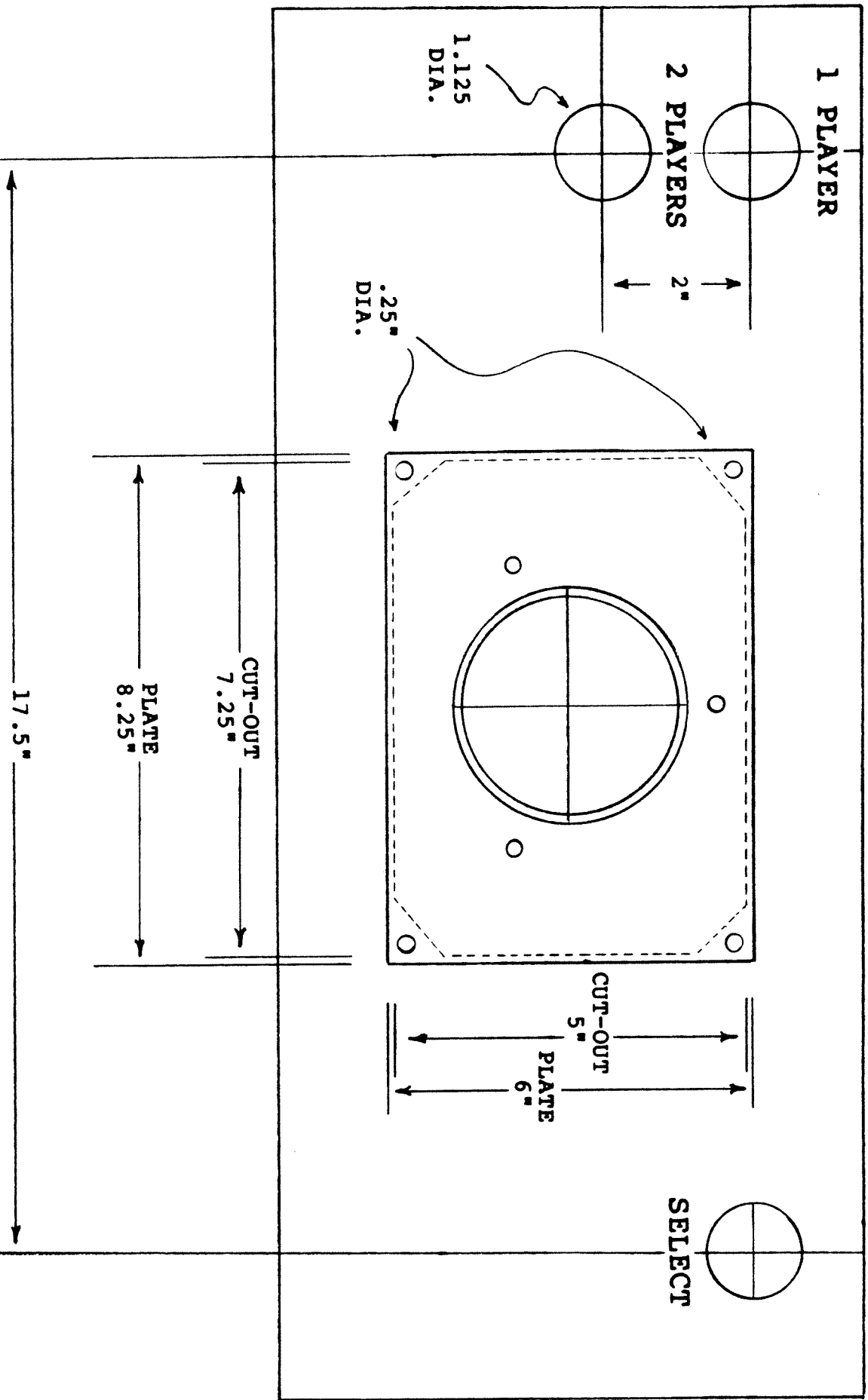

IF POSSIBLE, DO NOT  
OBSTRUCT ARTWORK