



Developer Note

Macintosh LC 520 Computer



Developer Note

Developer Press

© Apple Computer, Inc. 2000

🍏 Apple Computer, Inc.
© 2000, Apple Computer, Inc.
All rights reserved.

No part of this publication may be reproduced, stored in a retrieval system, or transmitted, in any form or by any means, mechanical, electronic, photocopying, recording, or otherwise, without prior written permission of Apple Computer, Inc. Printed in the United States of America.

The Apple logo is a registered trademark of Apple Computer, Inc. Use of the "keyboard" Apple logo (Option-Shift-K) for commercial purposes without the prior written consent of Apple may constitute trademark infringement and unfair competition in violation of federal and state laws.

No licenses, express or implied, are granted with respect to any of the technology described in this book. Apple retains all intellectual property rights associated with the technology described in this book. This book is intended to assist application developers to develop applications only for Apple Macintosh computers.

Apple Computer, Inc.
20525 Mariani Avenue
Cupertino, CA 95014
408-996-1010

Apple, the Apple logo, APDA, AppleLink, AppleTalk, LaserWriter, Macintosh, and SANE are trademarks of Apple Computer, Inc., registered in the United States and other countries.

AppleCD, AppleColor, Apple Desktop Bus, Apple SuperDrive, Macintosh Centris, Macintosh Quadra, Performa, PowerBook, QuickDraw, and System 7.0 are trademarks of Apple Computer, Inc.

Adobe Illustrator and PostScript are trademarks of Adobe Systems Incorporated, which may be registered in certain jurisdictions.

America Online is a service mark of Quantum Computer Services, Inc.

Classic is a registered trademark licensed to Apple Computer, Inc.

CompuServe is a registered service mark of CompuServe, Inc.

FrameMaker is a registered trademark of Frame Technology Corporation.

Helvetica and Palatino are registered trademarks of Linotype Company.

Internet is a trademark of Digital Equipment Corporation.

ITC Zapf Dingbats is a registered trademark of International Typeface Corporation.

Motorola is a registered trademark of Motorola Corporation.

NuBus is a trademark of Texas Instruments.

Trinitron is a trademark of Sony Corporation.

Simultaneously published in the United States and Canada.

LIMITED WARRANTY ON MEDIA AND REPLACEMENT

If you discover physical defects in the manual or in the media on which a software product is distributed, APDA will replace the media or manual at no charge to you provided you return the item to be replaced with proof of purchase to APDA.

ALL IMPLIED WARRANTIES ON THIS MANUAL, INCLUDING IMPLIED WARRANTIES OF MERCHANTABILITY AND FITNESS FOR A PARTICULAR PURPOSE, ARE LIMITED IN DURATION TO NINETY (90) DAYS FROM THE DATE OF THE ORIGINAL RETAIL PURCHASE OF THIS PRODUCT.

Even though Apple has reviewed this manual, APPLE MAKES NO WARRANTY OR REPRESENTATION, EITHER EXPRESS OR IMPLIED, WITH RESPECT TO THIS MANUAL, ITS QUALITY, ACCURACY, MERCHANTABILITY, OR FITNESS FOR A PARTICULAR PURPOSE. AS A RESULT, THIS MANUAL IS SOLD "AS IS," AND YOU, THE PURCHASER, ARE ASSUMING THE ENTIRE RISK AS TO ITS QUALITY AND ACCURACY.

IN NO EVENT WILL APPLE BE LIABLE FOR DIRECT, INDIRECT, SPECIAL, INCIDENTAL, OR CONSEQUENTIAL DAMAGES RESULTING FROM ANY DEFECT OR INACCURACY IN THIS MANUAL, even if advised of the possibility of such damages.

THE WARRANTY AND REMEDIES SET FORTH ABOVE ARE EXCLUSIVE AND IN LIEU OF ALL OTHERS, ORAL OR WRITTEN, EXPRESS OR IMPLIED. No Apple dealer, agent, or employee is authorized to make any modification, extension, or addition to this warranty.

Some states do not allow the exclusion or limitation of implied warranties or liability for incidental or consequential damages, so the above limitation or exclusion may not apply to you. This warranty gives you specific legal rights, and you may also have other rights which vary from state to state.

Contents

Figures and Tables	vii
Preface	About This Note ix
	Contents of This Note ix
	Supplemental Reference Documents x
	Conventions and Abbreviations xi
	Typographical Conventions xi
	Standard Abbreviations xi
Chapter 1	Introduction 1
	Summary of Features 2
	Comparison With the Macintosh Color Classic 2
	Comparison With the Macintosh LC III 3
	Integrated Design 3
	Front View 3
	Back View 4
	Access to the Logic Board 4
	Built-in Color Display 4
	Screen Control Pushbuttons 5
	Video RAM 6
	Power On and Off 6
	Power Saver 7
	RAM Expansion 8
	RAM Configurations 8
	RAM SIMM 8
	PDS Expansion Slot 10
	SCSI Bus 10
	SCSI Connectors 10
	SCSI Bus Termination 10
	Comparison of SCSI Arrangements 12
	Floppy Disk Drive 12
	Serial I/O Ports 13
	ADB Ports 15
	Sound 15
	Microphone 16
	Sound Input Jack 16
	Sound Control Pushbuttons 16
	Keyboard 16

Chapter 2	Architecture	19
	Block Diagram	20
	MC68030 Microprocessor	20
	Ardbeg Custom IC	20
	Ariel Custom IC	20
	Combo Custom IC	22
	Cuda ADB Controller	22
	Sound Circuits	22
	Sound Modes	22
	Sample Rates	23
	Address Map	23
	RAM Addresses	23
	Video RAM	25
	Video Display Timing	25
Chapter 3	Expansion	29
	Expansion Slot	30
	Pin Assignments	30
	Descriptions of the Signals	32
	The PDS Expansion Card	34
	Expansion Card Connectors	35
	Address Space for the Expansion Card	35
	Power for the Expansion Card	36
Chapter 4	Software	37
	ROM Software	38
	Unchanged Functions	38
	MMU Initialization	38
	Machine Identification	38
	RAM Sizing and Addressing	38
	One-Second Interrupt	39
	Pushbutton Interrupts	39
	Power Saver Software	39
	Video Software	39
	System Software	40
	System Enabler	40
	Booting From a CD-ROM	40
	New Control Panels	40
	Sound Control Panel	41
	Screen Control Panel	42

The Screen Driver	42
Screen Driver Calls	42
Open	43
Control	43
Status	44

Chapter 5	Internal Storage Devices	45
-----------	---------------------------------	----

Storage Device Slide-In Bays	46
Front Drive Bezel	47
Connector Adapters	48
Internal CD-ROM Drive	48
Dimensions of the CD-ROM Drive	48
Mounting Method for the CD-ROM Drive	50
Power for the CD-ROM Drive	50
Internal CD-ROM Integration	51

Appendix	AppleCD 300i Specifications	53
----------	------------------------------------	----

General Information	53
Specifications	53

Index	55
--------------	----

Foldouts	59
-----------------	----

Figures and Tables

Chapter 1	Introduction	1	
	Figure 1-1	Front view of the Macintosh LC 520 computer	4
	Figure 1-2	Back view of the Macintosh LC 520 computer	5
	Figure 1-3	Screen control panel	7
	Figure 1-4	RAM configurations	8
	Figure 1-5	RAM expansion SIMM	9
	Figure 1-6	Serial port sockets	14
	Table 1-1	VRAM size and number of colors	6
	Table 1-2	Pin assignments for the internal and external SCSI connectors	11
	Table 1-3	Pin assignments for the internal floppy disk connector	13
	Table 1-4	Serial port signals	14
	Table 1-5	ADB connector pin assignments	15
	Table 1-6	Reset and NMI key combinations	17
Chapter 2	Architecture	19	
	Figure 2-1	Block diagram	21
	Figure 2-2	24-bit and 32-bit address maps	24
	Figure 2-3	Standard video timing	26
	Figure 2-4	Video timing for the Apple IIe card	28
	Table 2-1	Video parameters for the standard display	25
	Table 2-2	Video parameters for the Apple IIe display	27
Chapter 3	Expansion	29	
	Figure 3-1	Generating the card select signal	35
	Table 3-1	Signals on the 96-pin section of the expansion connector	31
	Table 3-2	Signals on the 18-pin section of the expansion connector	32
	Table 3-3	Processor-direct expansion connector signal descriptions	32
	Table 3-4	Expansion slot signals not connected to the MC68030	33
	Table 3-5	Power available for the expansion card	36
Chapter 4	Software	37	
	Figure 4-1	Sound control panel	41
	Figure 4-2	Sound options	41
	Figure 4-3	Screen control panel	42

Chapter 5

Internal Storage Devices 45

Figure 5-1	Installation of the internal CD-ROM drive	46
Figure 5-2	Front drive bezel	47
Figure 5-3	Connector locations on the CD-ROM drive	48
Figure 5-4	Connector locations on the hard disk drive	49
Figure 5-5	Dimensions of the CD-ROM drive	49
Figure 5-6	The AppleCD 300i mounted on the sled	50
Figure 5-7	Pins on the CD-ROM audio connector	51
Table 5-1	Power available for the AppleCD 300i CD-ROM drive	50

Appendix

AppleCD 300i Specifications 53

Table A-1	AppleCD 300i specifications	53
------------------	-----------------------------	----

About This Note

This developer note provides information about the Macintosh LC 520 computer, an integrated model with a built-in 14-inch color display. The Macintosh LC 520 has about the same performance as the Macintosh LC III.

Note

While every attempt has been made to verify the accuracy of the information presented here, it is subject to change without notice. The primary reason for releasing this type of product information is to provide the development community with essential product specifications, theory, and application information for the purpose of stimulating work on compatible third-party products. ♦

Contents of This Note

The information is arranged in five chapters, an Appendix, and a set of foldouts:

- Chapter 1, “Introduction,” gives a summary of the features and describes the external features of the Macintosh LC 520 computer.
- Chapter 2, “Architecture,” includes a block diagram and address maps and describes the integrated circuits that are specific to the Macintosh LC 520 computer.
- Chapter 3, “Expansion,” describes the single expansion slot in the Macintosh LC 520 computer and the expansion card that plugs into it.
- Chapter 4, “Software,” summarizes the features of the ROM software and tells how the system software operates on the Macintosh LC 520 computer.
- Chapter 5, “Internal Storage Devices,” is a developer guide for storage devices to be installed inside the Macintosh LC 520 computer.
- The Appendix gives the specifications for the AppleCD 300i, the internal CD-ROM drive for the Macintosh LC 520 computer.
- The foldouts provide engineering specifications and mechanical drawings for selected parts.

Supplemental Reference Documents

To supplement the information in this developer note, developers should have copies of the appropriate Apple reference books, including *Inside Macintosh*, Volumes IV, V, and VI; *Guide to the Macintosh Family Hardware*, second edition; and *Designing Cards and Drivers for the Macintosh Family*, third edition. These books are available in technical bookstores and through APDA.

Because the Macintosh LC 520 computer has many of the features of the Macintosh LC II and LC III computers, developers should also have copies of the developer notes that describe the Macintosh LC, LC II, and LC III. Those are, respectively:

- *Macintosh IIsx, LC, and Classic Developer Notes*, APDA catalog number M0991LL/A
- *Macintosh Developer Note Number 1*, APDA catalog number R0451LL/A
- *Macintosh Developer Note Number 3*, APDA catalog number R0461LL/A

The developer notes are available from APDA and are also on the developer CDs—the most recent, *Macintosh Developer Note Number 3*, has been available since March 1993.

Note

The numbered developer notes are collections that describe several Macintosh models. In addition to the Macintosh LC II computer, *Macintosh Developer Note Number 1* also covers the Macintosh IIfx, the Macintosh PowerBook 145, 160, and 180, and the Macintosh Quadra 950. Similarly, *Macintosh Developer Note Number 3* covers the Macintosh Color Classic, the Macintosh PowerBook 165c, the Macintosh Centris 610 and 650, and the Macintosh Quadra 800 in addition to the Macintosh LC III. ♦

APDA is Apple's worldwide source for over three hundred development tools, technical resources, training products, and information for anyone interested in developing applications on Apple platforms. Customers receive the quarterly *APDA Tools Catalog* featuring all current versions of Apple development tools and the most popular third-party development tools. Ordering is easy; there are no membership fees, and application forms are not required for most of our products. APDA offers convenient payment and shipping options, including site licensing.

P R E F A C E

To order products or to request a complimentary copy of the *APDA Tools Catalog*, contact

APDA
Apple Computer, Inc.
P.O. Box 319
Buffalo, NY 14207-0319

Telephone	800-282-2732 (United States) 800-637-0029 (Canada) 716-871-6555 (International)
Fax	716-871-6511
AppleLink	APDA
America Online	APDA
CompuServe	76666,2405
Internet	APDA@applelink.apple.com

Conventions and Abbreviations

This developer note uses typographical conventions and abbreviations that are standard in Apple publications.

Typographical Conventions

This note uses the following typographical conventions.

New terms appear in **boldface** where they are first defined.

Computer-language text—any text that is literally the same as it appears in computer input or output—appears in *Courier* font.

Standard Abbreviations

When unusual abbreviations appear in this book, the corresponding terms are also spelled out. Standard units of measure and other widely used abbreviations are not spelled out.

Here are the standard units of measure used this developer note:

A	amperes	K	1024
dB	decibels	KB	kilobytes
GB	gigabytes	kg	kilograms
Hz	hertz	kHz	kilohertz
in.	inches	k Ω	kilohms
k	1000	lb.	pounds

P R E F A C E

mA	milliamperes	μ s	microseconds
μ A	microamperes	ns	nanoseconds
MB	megabytes	sec.	seconds
MHz	megahertz	V	volts
mm	millimeters	W	watts
ms	milliseconds	Ω	ohms

Here are other abbreviations used in this developer note:

$\$n$	hexadecimal value n
AC	alternating current
ADB	Apple Desktop Bus
CD-ROM	compact-disk read-only memory
CLUT	color lookup table
EMI	electromagnetic interference
FPU	floating-point unit
IC	integrated circuit
I/O	input/output
LS	low-power Schottky (used as a standard for IC device loads)
MMU	memory management unit
MOS	metal-oxide semiconductor
NMI	nonmaskable interrupt
PRAM	parameter RAM
PWM	pulse-width modulation
RAM	random-access memory
RMS	root-mean-square
ROM	read-only memory
SANE	Standard Apple Numerics Environment
SCC	serial communications controller
SCSI	Small Computer System Interface
SIMM	single inline memory module
SWIM	Super Woz Integrated Machine, a custom IC that controls the floppy disk interface
TTL	transistor-transistor logic (used as a standard for IC device loads)
VRAM	video RAM

Introduction

Introduction

The Macintosh LC 520 computer is an integrated Macintosh computer with a built-in color display. It is a larger version of the Macintosh Color Classic[®] with many of the performance features of the Macintosh LC III.

This chapter outlines the main features of the Macintosh LC 520 computer and describes its appearance and external features.

Summary of Features

Here is a summary of the hardware features of the Macintosh LC 520 computer (individual features are described in the sections that follow):

- integrated design with built-in 14-inch Trinitron color display
- Motorola MC68030 microprocessor running at 25 MHz
- built-in video hardware using separate video RAM
- installed RAM capacity of 4 MB, expandable to 36 MB
- 1 MB ROM in sockets; optional expansion to 2 MB
- internal hard disk with 40 MB, 80 MB, or 160 MB capacity, using the internal SCSI connector; external SCSI port for additional SCSI devices
- provision for an internal CD-ROM drive or other 5.25-inch storage device
- internal Apple SuperDrive high-density floppy disk drive with 1.4 MB capacity
- standard Macintosh I/O ports: two ADB ports, two serial ports, sound input and output jacks, and a SCSI port
- built-in microphone
- front-panel headphone jack and internal stereo speakers
- 114-pin processor-direct slot (PDS) for hardware expansion (like the PDS on the Macintosh LC III, and compatible with the 96-pin PDS on the Macintosh Color Classic and the Macintosh LC II)
- power on and off from the keyboard
- pushbuttons on the front panel to control sound volume and display intensity
- power saver mode to allow software to turn off the display monitor when the machine is unused for a set period of time

Comparison With the Macintosh Color Classic

Here is a summary of features of the Macintosh LC 520 that are different from those of the Macintosh Color Classic:

- larger 14-inch Trinitron color display
- microprocessor running at 25 MHz instead of 16 MHz; data bus 32 bits wide instead of 16 bits.

Introduction

- integrated case larger than that of the Macintosh Color Classic
- RAM expandable to 36 MB instead of 10 MB
- two internal speakers for stereo sound output
- two sound output jacks, one in front, one in back
- provision for an internal CD-ROM drive
- extended processor-direct slot (PDS) for hardware expansion

Comparison With the Macintosh LC III

The Macintosh LC 520 computer combines the integrated design of the Macintosh Color Classic with many of the functions and capabilities of the Macintosh LC III. Here is a summary of features of the Macintosh LC 520 that are different from those of the Macintosh LC III:

- integrated design with a built-in 14-inch Trinitron color display
- front-panel pushbuttons to control sound level and screen intensity
- built-in microphone
- stereo sound output, with built-in stereo speakers
- two sound output jacks, one in front, one in back
- provision for an internal CD-ROM drive
- expansion socket for the system ROM
- no external video connector
- a different ADB controller IC (the Cuda)

Integrated Design

The Macintosh LC 520 computer has an integrated design similar to that of the Macintosh Color Classic.

Front View

Figure 1-1 on page 4 shows the front of the Macintosh LC 520 computer, including the display screen, the floppy disk slot, the CD-ROM slot, the front-panel headphone jack, and the pushbuttons that control the screen intensity and sound level.

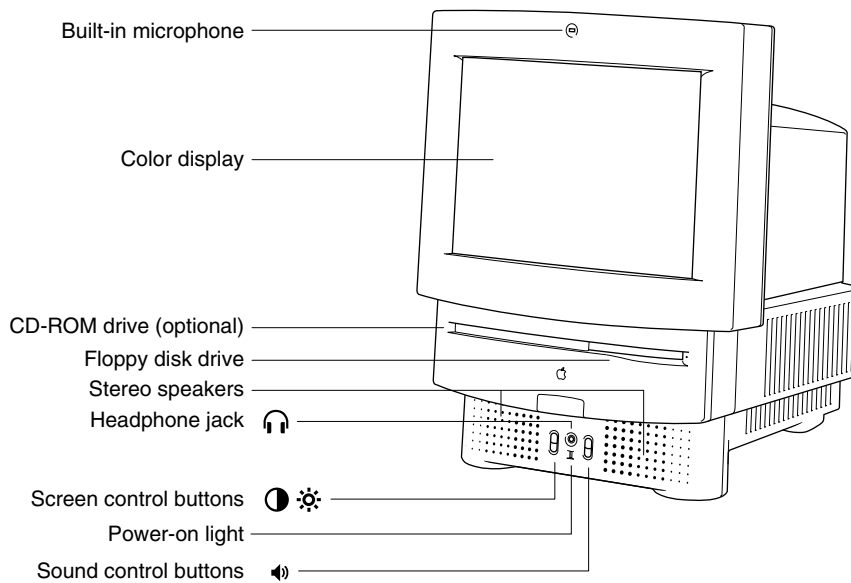
Figure 1-1 Front view of the Macintosh LC 520 computer

Back View

Figure 1-2 shows the back of the Macintosh LC 520 computer. The master power switch is located just beneath the fan grille. The external connectors are located in a row across the lower part of the back.

Access to the Logic Board

Just above the row of I/O connectors on the back of the computer are two projecting tabs. By pushing down on the tabs, the user can remove the connector cover and gain access to the main logic board. The logic board has a custom connector that plugs into a socket at the front so that the user can remove the board from the case by pulling it out the back. Once the board has been removed, the user can add expansion RAM or plug in an expansion card, as described in later sections of this note.

Built-in Color Display

The Macintosh LC 520 computer has a built-in color display with a 14-inch Trinitron monitor. Like the video interface in the Macintosh Color Classic, the video interface in the Macintosh LC 520 computer uses separate VRAM for the screen buffer. The Macintosh LC 520 does not have an external video connector.

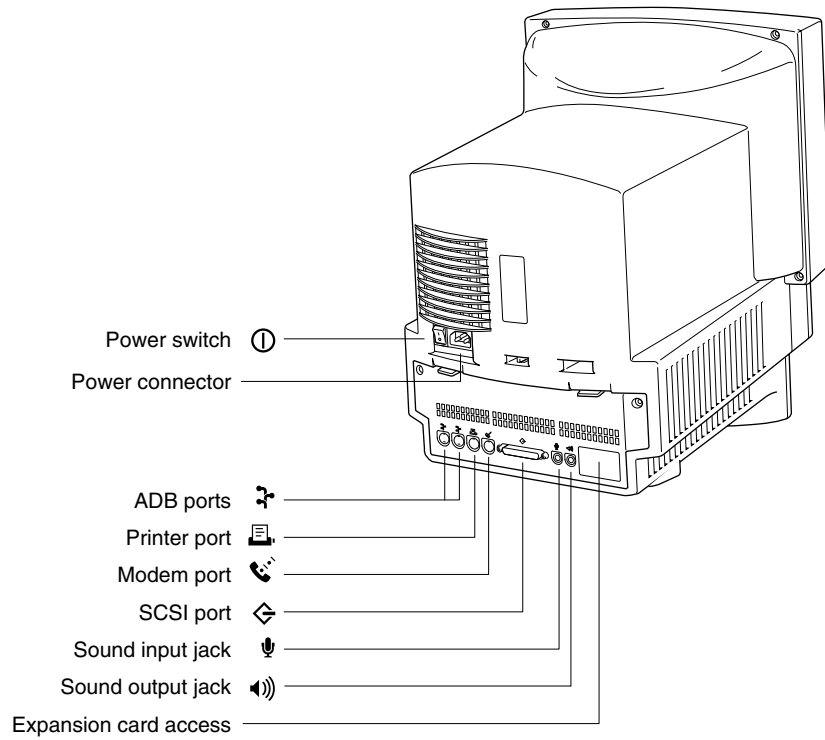
Figure 1-2 Back view of the Macintosh LC 520 computer

The display screen in the Macintosh LC 520 computer displays the same amount of information as the Macintosh 14-inch color display: 640 by 480 pixels.

Note

The Macintosh LC 520 computer also provides a 16-color, 560-by-384-pixel display mode when an Apple IIe Card is installed in the expansion slot. ♦

Screen Control Pushbuttons

The Macintosh LC 520 computer has two pairs of pushbuttons on the front panel. The pair on the left controls the intensity of the screen: pressing the top button causes the intensity to increase, and pressing the bottom button causes the intensity to decrease. If the user holds down a button, the intensity continues to increase (or decrease) until it reaches a maximum (or minimum). (The pair of pushbuttons on the right controls the sound level.)

Note

The user can also control the screen brightness and contrast by means of the Screen control panel, described in the section “Screen Control Panel” on page 42. ♦

Video RAM

The Macintosh LC 520 computer comes with 512 KB of VRAM and a socket for a SIMM with an additional 256 KB of VRAM. The VRAM expansion SIMM is the same 68-pin SIMM used with the Macintosh LC III and Macintosh Quadra computers. It requires VRAM devices with access times of 80 ns or less.

The basic 512 KB VRAM provides up to 8 bits per pixel; the screen displays up to 256 colors, software-selectable from a range of 16 million. With the VRAM SIMM installed, the Macintosh LC 520 has 768 KB of VRAM, allowing it to display up to 16 bits per pixel, which provides 32,768 colors. If the VRAM SIMM has been installed, the user can set the display to 16 bits per pixel by opening the Monitors control panel and choosing Thousands.

Table 1-1 lists the bits per pixel and numbers of colors available for the different sizes of VRAM.

Table 1-1 VRAM size and number of colors

VRAM size	Bits per pixel	Number of colors
512 KB	1, 2, 4, or 8	2, 4, 16, or 256
768 KB	1, 2, 4, 8, or 16	2, 4, 16, 256, or 32,768 (only 15 bits are used)

Power On and Off

The master power switch on the back of the computer must be in the On position for the computer to operate. As long as the master power switch is in the On position, the user can turn the power off and on by pressing the power key on the keyboard.

Note

If you plan to leave the computer turned off for an extended period of time, you should flip the master power switch to the Off position. ♦

If the user attempts to turn off the computer—using either the power key or the Shut Down menu item—while files are still open, the system displays an alert box warning the user that files are open and should be closed to avoid loss of data. If the user turns off the master power switch while the computer is operating, the computer shuts off immediately, without performing the safe shutdown.

Power Saver

The power saver is an optional feature that automatically turns off the display whenever the Macintosh LC 520 computer is turned on but is not used for more than a set period of time. The user selects the power saver and sets the length of time before the screen turns off by adjusting the slider in the Screen control panel, shown in Figure 1-3. After the power saver has turned the display off, the software turns the display back on again whenever the user moves the mouse or presses a key on the keyboard.

Figure 1-3 Screen control panel

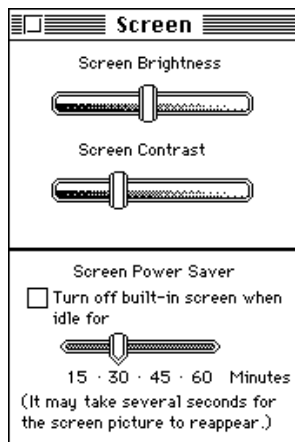

Note

It may take up to several seconds for the screen display to reappear. To let the user know that it has responded to the user's action, the computer emits a series of beeps while this is happening. ♦

RAM Expansion

The Macintosh LC 520 computer comes with 4 MB of RAM built in. By installing a SIMM, the user can expand the RAM up to a maximum of 36 MB.

RAM Configurations

Figure 1-4 shows the RAM configurations for different amounts of RAM. For more information, see the section “RAM Addresses” on page 23.

Figure 1-4 RAM configurations

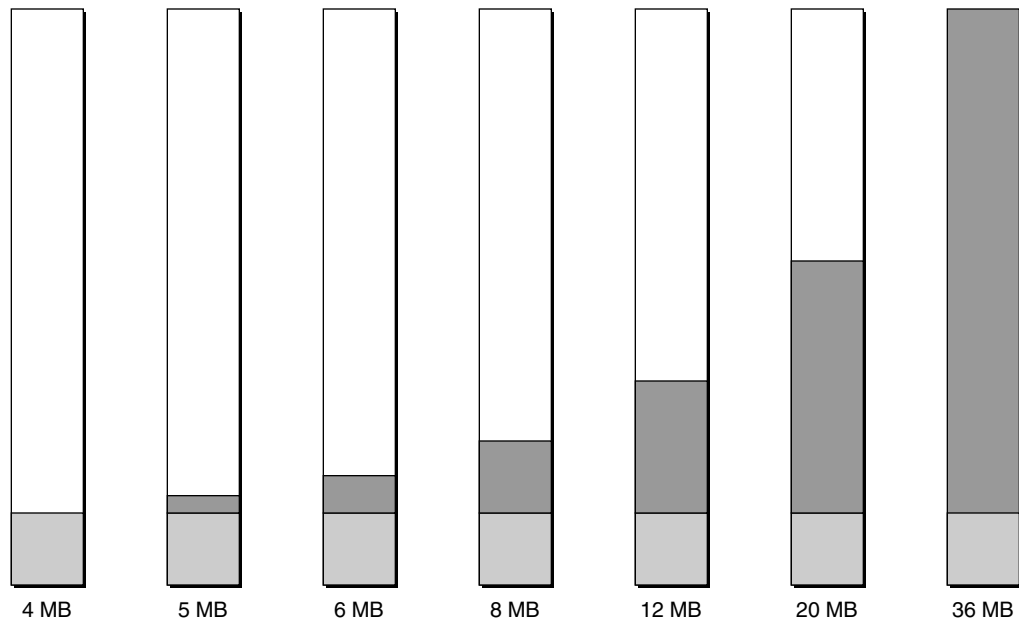

RAM SIMM

The Macintosh LC 520 computer accepts one 72-pin RAM SIMM, illustrated in Figure 1-5. The access time of the RAM must be 80 ns or less. The RAM SIMM can contain 1 MB, 2 MB, 4 MB, 8 MB, 16 MB, or 32 MB of additional RAM.

Note

The SIMM used in the Macintosh LC 520 computer is not the same as the 30-pin SIMMs used on some other Macintosh computers. ♦

Figure 1-5 RAM expansion SIMM

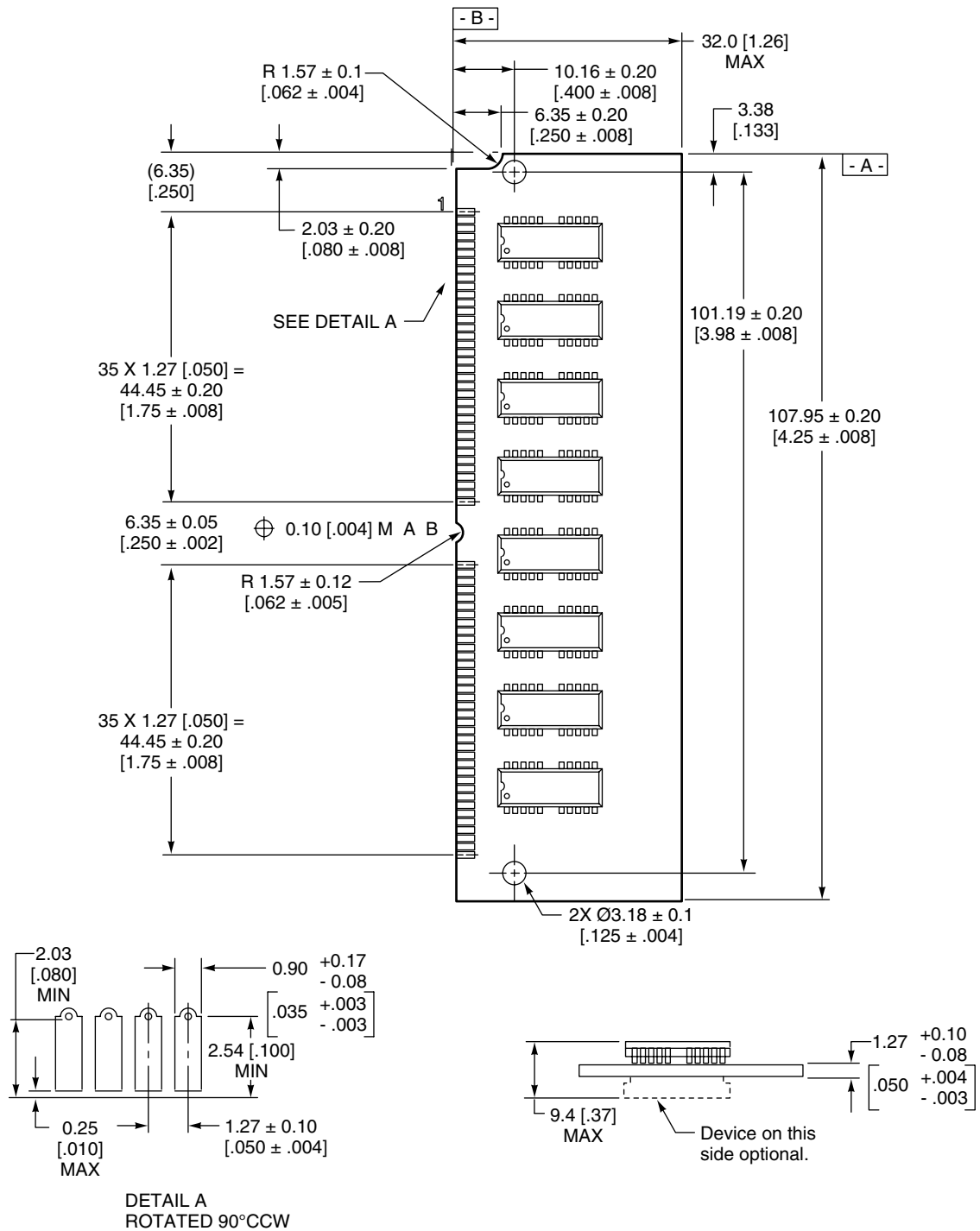

Note: Dimensions are in millimeters with inches in brackets.

PDS Expansion Slot

The Macintosh LC 520 computer has a single internal 114-pin expansion connector that provides direct access to the MC68030 microprocessor from an optional expansion card. The connector can accept a 96-pin expansion card similar to the PDS card for the Macintosh Color Classic. Like the PDS connector on the Macintosh LC III, it can also accept an expansion card that uses all 114 pins to make better use of the power of the MC68030 microprocessor. Chapter 3, “Expansion,” describes the signals on the PDS connector and gives guidelines for designing a PDS card for the Macintosh LC 520.

Note

The PDS connector in the Macintosh LC 520 computer accepts the Apple IIe Card for the Macintosh LC. The internal display provides a 560-by-384-pixel, 16-color display for running Apple IIe software. ♦

SCSI Bus

In addition to the internal hard drive and one or more external SCSI devices, the SCSI bus on the Macintosh LC 520 computer supports the optional internal CD-ROM drive.

SCSI Connectors

The internal SCSI connector is a 50-pin connector with the standard SCSI pin assignments. The external SCSI connector is a 25-pin D-type connector with the same pin assignments as those in other Apple SCSI devices. Table 1-2 shows the pin assignments on the internal and external SCSI connectors.

The internal hard disk and optional CD-ROM drive connect to the SCSI bus by means of connector adapters that allow the drives to slide into their respective mounting bays. For more information about the internal drives and connector adapters, see Chapter 5, “Internal Storage Devices.”

SCSI Bus Termination

Because the internal portion of the SCSI bus must be long enough to connect multiple devices, the bus requires termination at both ends. As on other Macintosh models, the external end of the bus is normally terminated at the last external device. On the Macintosh LC 520 computer, the internal end of the bus—the end at the last internal hard disk drive—is terminated in the drive itself.

Introduction

Table 1-2 Pin assignments for the internal and external SCSI connectors

Internal (50-pin)	External (25-pin)	Signal name
2	8	/DB0
4	21	/DB1
6	22	/DB2
8	10	/DB3
10	23	/DB4
12	11	/DB5
14	12	/DB6
16	13	/DB7
18	20	/DBP
20, 22, 24, 28, 30, and 34	–	n.c.
26	25	TPWR
32	17	/ATN
36	6	/BSY
38	5	/ACK
40	4	/RST
42	2	/MSG
44	19	/SEL
46	15	/C/D
48	1	/REQ
50	3	/I/O
All odd pins (25 total)	7, 9, 14, 16, 18, and 24	GND

The Macintosh LC 520 computer includes a new feature that automatically provides the proper termination when no external device is connected, that is, when the SCSI bus ends at the external connector. When no external device is connected, special circuitry connects the bus to a terminator on the logic board near the external connector. When one or more external SCSI devices are connected, the circuitry detects the external termination during system reset and disconnects the termination on the logic board.

Comparison of SCSI Arrangements

There are now three arrangements of SCSI cabling and termination used in Macintosh computers.

The first arrangement is used on Macintosh computers that support only one internal SCSI device (examples include the Macintosh LC II and the Macintosh Quadra 700). Terminators built into the internal SCSI device terminate the internal end of the SCSI bus. A separate terminator block at the last external device terminates the external end of the SCSI bus.

The second arrangement is used on the Macintosh Quadra 900 and 950 computers. Those machines have two SCSI driver ICs, one for the internal SCSI devices and one for the external devices. (The software treats the two hardware buses as one virtual bus with a single set of SCSI ID numbers.) The internal and external SCSI cables are both terminated on the logic board. In addition, the internal cable is so long that it—like the external cable—requires termination at both ends, so it has built-in SCSI terminators for the last device. While this arrangement provides for higher transmission speeds because the two segments of the bus are terminated separately, it is expensive because it has two driver ICs and two sets of active terminators on the logic board.

The third arrangement is used in the Macintosh LC 520 computer as well as other recently introduced models with more than one internal SCSI device (such as the Macintosh IIvx and the Macintosh Centris 650). As described earlier, that arrangement uses a single SCSI driver IC for both internal and external devices and provides automatic termination on the logic board.

Floppy Disk Drive

The Macintosh LC 520 computer supports one internal high-density floppy disk drive (Apple SuperDrive). The drive is connected to the logic board by a 20-pin connector. Table 1-3 shows the pin assignments for the floppy disk connector.

The floppy disk drive uses a special connector adapter that allows it to be installed by sliding it into a bay in the computer's chassis. See Chapter 5, "Internal Storage Devices," for information about connector adapters.

Table 1-3 Pin assignments for the internal floppy disk connector

Pin number	Signal name	Signal description
1	GND	Ground
2	PH0	Phase 0: state control line
3	GND	Ground
4	PH1	Phase 1: state control line
5	GND	Ground
6	PH2	Phase 2: state control line
7	GND	Ground
8	PH3	Phase 3: register write strobe
9	n.c.	Not connected
10	/WRREQ	Write data request
11	+5V	+5 volts
12	SEL	Head select
13	+12V	+12 volts
14	/ENBL	Drive enable
15	+12V	+12 volts
16	RD	Read data
17	+12V	+12 volts
18	WR	Write data
19	+12V	+12 volts
20	n.c.	Not connected

Serial I/O Ports

The Macintosh LC 520 computer has two serial ports, one for a printer and one for a modem. The printer port uses the standard 8-pin mini-DIN socket. The modem port uses a 9-pin mini-DIN socket. Both sockets accept 8-pin plugs, but only the modem port accepts a 9-pin plug. Figure 1-6 on page 14 shows the mechanical arrangement of the pins on the serial port sockets; Table 1-4 on page 14 shows the signal assignments.

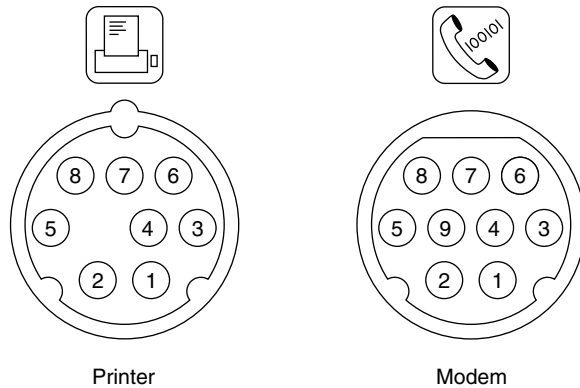
Figure 1-6 Serial port sockets**Table 1-4** Serial port signals

Pin number	Signal description
1	Handshake output
2	Handshake input
3	Transmit data -
4	Ground
5	Receive data -
6	Transmit data +
7	General-purpose input
8	Receive data +
9	+5 volts (modem port only)

The extra pin on the modem connector provides +5V power from the ADB power supply. A modem should draw no more than 100 mA from that pin. The total current available for all devices connected to the +5V supply for the ADB and the modem port is 500 mA.

Both serial ports include the GPi (general-purpose input) signal on pin 7. The GPi signal for each port connects to the corresponding data carrier detect input on the SCC (Serial Communications Controller). On serial port A (the modem port), the GPi line can be connected to the receive/transmit clock (RTxCA) signal on the SCC. That connection supports devices that provide separate transmit and receive data clocks, such as synchronous modems. For more information about the serial ports, see *Guide to the Macintosh Family Hardware*, second edition.

ADB Ports

The ADB ports are functionally the same as those on other Macintosh computers.

The Apple Desktop Bus is a single-master, multiple-slave serial communications bus that uses an asynchronous protocol and connects keyboards, graphics tablets, mouse devices, and other devices to the Macintosh LC 520 computer. The custom ADB microcontroller drives the bus and reads status from the selected external device. A 4-pin mini-DIN connector connects the ADB controller to the outside world. Table 1-5 lists the ADB connector pin assignments. For more information about the ADB, see *Guide to the Macintosh Family Hardware*, second edition.

Table 1-5 ADB connector pin assignments

Pin number	Name	Description
1	ADB	Bidirectional data bus used for input and output. It is an open-collector signal pulled up to +5 volts through a 470-ohm resistor on the main logic board.
2	PSW	Power-on signal that generates reset and interrupt key combinations.
3	+5V	+5 volts from the computer. A 1-ampere fuse at the output satisfies safety requirements.
4	GND	Ground from the computer.

Note

The total current available for all devices connected to the +5V pins on the ADB and the modem port is 500 mA. Each device should use no more than 100 mA. ♦

Sound

Like other Macintosh computers, the Macintosh LC 520 computer can create sounds digitally and play the sounds through its internal stereo speakers or send the sound signals out through the sound out connectors. For recording sound, the Macintosh LC 520 computer has a built-in microphone as well as an external sound input jack.

The sound system includes a playthrough feature that allows an external audio source to be mixed with computer-generated sound and played through the speakers or the sound out connector. For more information, see the section “Sound Modes” beginning on page 22.

Microphone

The Macintosh LC 520 computer has a built-in microphone at the front of the case. The microphone is connected internally to the main logic board.

The user selects the built-in microphone as the sound source by using the Sound control panel. For more information, see the section “Sound Control Panel” beginning on page 41.

Sound Input Jack

There is a sound input jack on the back of the computer for connecting an external microphone or other sound source. The sound input jack accepts a standard $\frac{1}{8}$ -inch phone plug, either monophonic or stereophonic (two signals plus ground).

The sound input jack accepts either the external microphone for the Macintosh LC 520 computer or a pair of line-level (amplified) signals. When the user selects the corresponding input device in the Sound control panel, the computer sets the gain appropriately. The internal circuitry mixes the pair of stereophonic signals into a monophonic signal.

Note

The external microphone requires power from the main computer, which it obtains by way of an extra-long, 4-conductor plug that makes contact with a 5-volt pin inside the sound input jack. ♦

Sound Control Pushbuttons

The Macintosh LC 520 computer has two pairs of pushbuttons on the front panel. The pair of buttons on the right controls the sound level: pressing the top button causes the level to increase, and pressing the bottom button causes the level to decrease. (The left pair of pushbuttons controls the intensity of the display.) If the computer is playing a sound when you press one of the sound control pushbuttons, the sound level changes as long as you continue to press the button. If no sound is playing when you press a sound control pushbutton, the computer plays an alert sound to confirm the new level setting.

Keyboard

The Macintosh LC 520 computer comes with a separate keyboard like the one used with the Macintosh Color Classic. The keyboard has a power key, identified by the symbol ⏻.

There are no programmer’s switches on the Macintosh LC 520 case, so the reset and NMI functions are generated by pressing the power key on the keyboard while holding down other keys, as shown in Table 1-6. The Command key is identified by the symbols ⌘ and ⌘.

Introduction

Note

The user must hold down a key combination for at least 1 second to allow the ADB microcontroller enough time to respond to the NMI or hard-reset signal. ♦

Table 1-6 Reset and NMI key combinations

Key combination	Function
Power (⌘)	Power on and off
Command-Power (⌘-⌘)	NMI (always active)
Control-Command-Power (Control-⌘-⌘)	Reset

Note

The NMI in the Macintosh LC 520 computer can always be activated from the keyboard. This is a change from the Macintosh LC computer, where the keyboard NMI function can be deactivated by the software. ♦

Architecture

This chapter describes the architecture of the Macintosh LC 520 computer. It describes the main components on the logic board and explains the features that are different from those of earlier Macintosh computers.

Block Diagram

The architecture of the Macintosh LC 520 computer is based on the design of the Macintosh LC III. The Macintosh LC 520 uses several new custom ICs, as shown in the block diagram in Figure 2-1.

MC68030 Microprocessor

The Macintosh LC 520 computer uses a Motorola MC68030 microprocessor running at a clock speed of 25 MHz.

The Macintosh LC 520 computer does not have a built-in floating-point unit (FPU). The main circuit board has a socket for adding an FPU. Also, an expansion board can provide an FPU, because the /FPU select signal is available on the expansion connector. For more information, see Chapter 3, “Expansion.”

Ardbeg Custom IC

A custom IC called Ardbeg combines several functions performed by individual ICs in older machines:

- timing and clock generation
- memory mapping
- VIA1 and VIA2 registers
- video addressing and timing
- SWIM II floppy disk interface
- sound timing and control
- interface to front-panel pushbuttons

The VIA functions are similar to those in the Macintosh LC III. The first VIA is a full-function VIA, and the second is a set of registers like those in the V8 custom IC.

Ariel Custom IC

Another custom IC, called Ariel, contains the video CLUT (color look-up table) and DAC. The Ariel IC is pin and software compatible with the AC843 but does not support 24 bits per pixel. For information about the number of bits per pixel provided on different video monitors, see the section “Video RAM” on page 25.

Figure 2-1 Block diagram

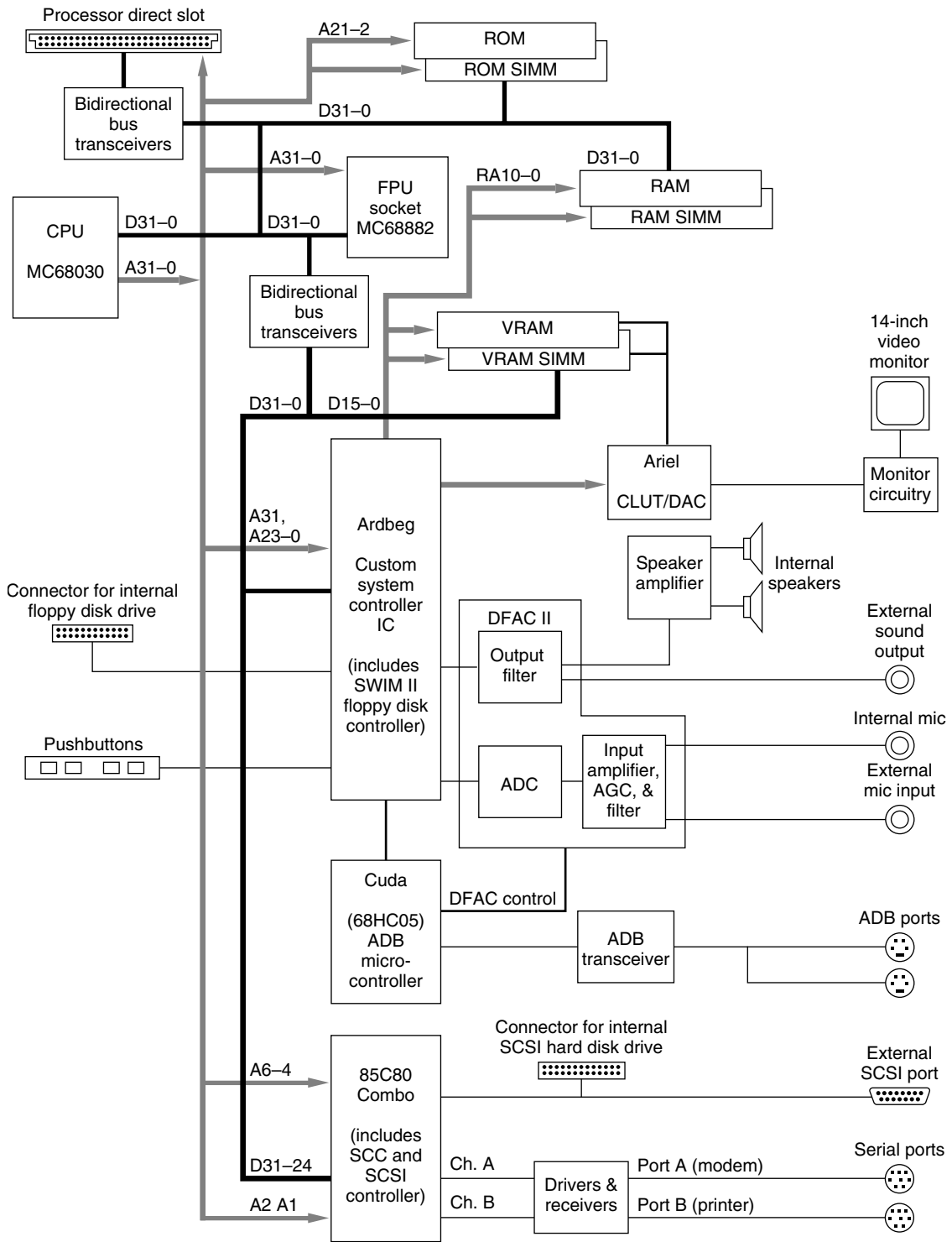

Combo Custom IC

In the Macintosh LC 520 computer, the functions of two interface ICs, the SCC (85C30) and the SCSI (53C80), are combined into one device, the Combo IC (85C80). The SCSI port on the Macintosh LC 520 is the same as that on the Macintosh LC III.

The SCC (serial) ports are also like their counterparts except that they include the GPi signal (on pin 7). The GPi signal can be used for input handshaking or for a receive clock input to support a synchronous modem. The pin assignments for the serial ports are listed in Table 1-4 on page 14.

Cuda ADB Controller

The Cuda IC is a version of the 68HC05 microcontroller. It provides the ADB interface and control signals to the DFAC II IC along with parameter RAM, the real-time clock, and soft-power control. For a description of soft power, see the section “Power On and Off” beginning on page 6.

Sound Circuits

The analog sound processing devices in the Macintosh LC 520 computer are built into a custom IC called the DFAC II. In addition, the Ardbeg custom IC performs sound routing and control along with its other digital functions.

For sound input, the DFAC II processes the signal from the internal microphone or the sound input jack through a sound input amplifier (with automatic gain control), an input filter, an A/D converter, and the necessary switching circuits.

For sound output, circuits in the Ardbeg custom IC receive data from the sound buffer and generate a pulse-width-modulated (PWM) signal that is sent to the DFAC II. After low-pass filtering in the DFAC II, the signal is sent to the sound output jacks and to separate amplifiers that drive the built-in speakers. Inserting a plug into either sound output jack disconnects the internal speakers.

Sound Modes

The DFAC II is normally used in one of four modes of operation:

- Sound playback: computer-generated sound is sent to the speaker and the sound output jack.
- Sound playback with playthrough: computer sound and sound input are mixed and sent to the output.
- Sound record: sound input is recorded; this is the preferred method for recording, especially when using the built-in microphone.
- Sound record with playthrough: input sound is recorded and also fed through to the output.

Architecture

One way of using sound record with playthrough is in the recording of sounds from a CD or CD-ROM.

IMPORTANT

As in the Macintosh LC, the sound mode is selected by means of a call to the Sound Manager. To prevent feedback that might be audible, an application should not let the user select playthrough mode when either microphone has been selected as the sound input source. For more information, see the section “Sound Control Panel” beginning on page 41. ▲

Sample Rates

The Macintosh LC 520 computer records and plays back sound at either of two sample rates: 11k samples per second and 22k samples per second. For sound input, the system switches the input filter between two cutoff frequencies that correspond to the two sampling rates: 3.5 kHz cutoff for the 11k sample rate and 7 kHz cutoff for the 22k sample rate.

Similarly on playback, the system switches between a filter with a 3.5 kHz cutoff frequency for sounds at 11k samples per second and a 7 kHz filter for sounds at 22k samples per second.

Address Map

The Macintosh LC 520 computer supports both 24-bit and 32-bit addressing. Figure 2-2 on page 24 shows the relationship between the 24-bit addresses and the 32-bit addresses. The address map is similar to that of the Macintosh LC III.

Note

Developers should not use actual hardware addresses in applications but should always communicate with hardware devices by means of system software. ◆

RAM Addresses

The first 1 GB of the address space is reserved for RAM. The actual amount of RAM installed can be from 4 MB to 36 MB. At startup time, a routine in the ROM determines the amount of RAM available and stores the size in a low-memory global variable.

Figure 2-2 24-bit and 32-bit address maps

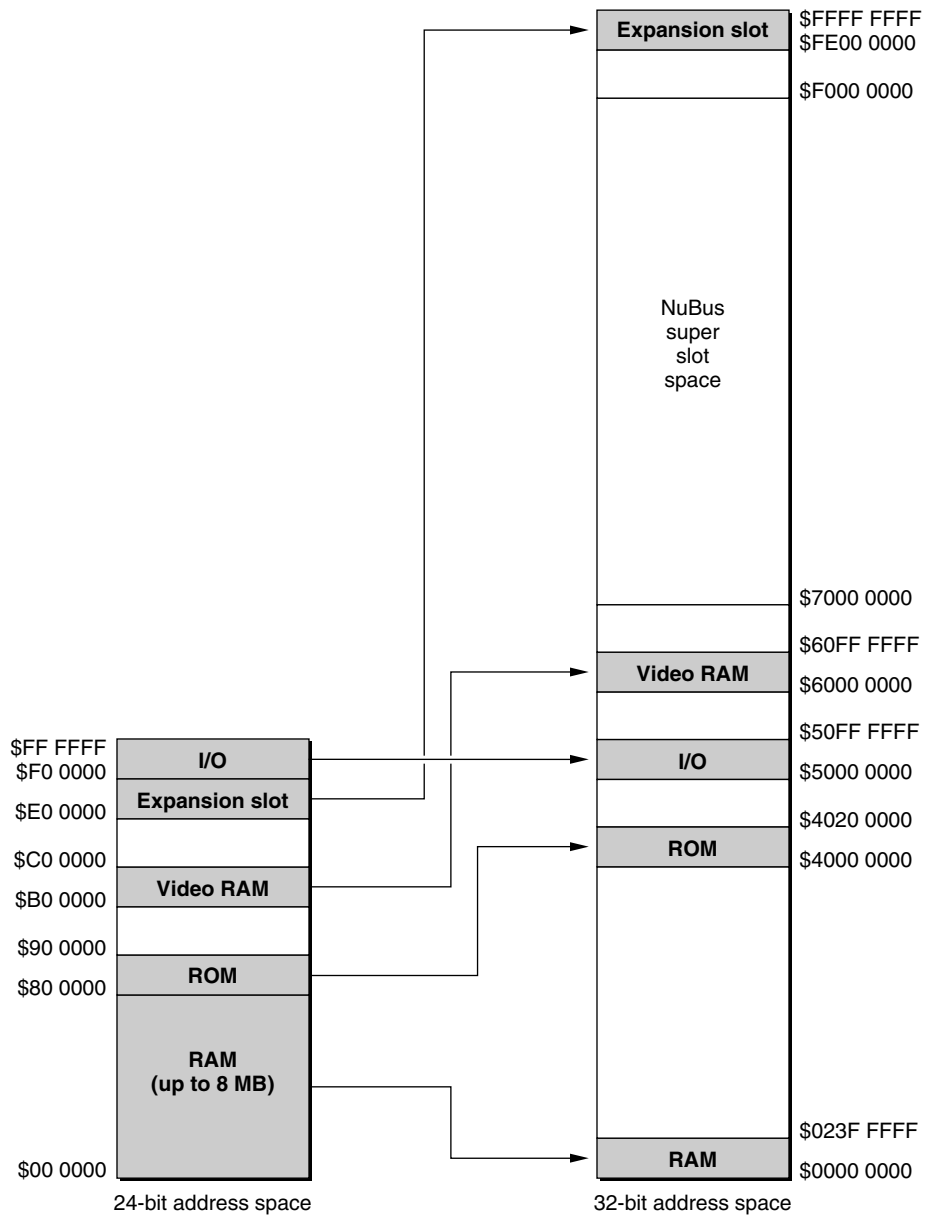

Video RAM

The Macintosh LC 520 computer uses separate video RAM (VRAM) to store the screen buffer. The video RAM occupies a dedicated address space, as shown in Figure 2-2.

The computer comes with 512 KB of VRAM soldered to the main logic board. A 68-pin SIMM socket accepts an additional 256 KB for a total of 768 KB of VRAM. The VRAM SIMM is the same size and has the same pin assignments as the VRAM expansion SIMM for the Macintosh Display Card 8•24. The system interface to the VRAM is a 16-bit data bus using bits 31–16.

Note

The 256 KB VRAM SIMM used in the Macintosh LC 520 computer is the same as that used in the Macintosh Color Classic; it is not the same as the 512 KB VRAM SIMM used in the Macintosh LC and Macintosh LC II computers. ♦

A color lookup table (CLUT) provides color values for 4-bit and 8-bit video modes. With the Monitors control panel set to black-and-white, the CLUT is still used, but all three color components (R, G, and B) are the same.

Video Display Timing

The standard video display on the Macintosh LC 520 computer has the same number of pixels as the display used with the AppleColor High-Resolution RGB Monitor: 640 by 480 pixels. Table 2-1 lists the video parameters; Figure 2-3 on page 26 shows the timing and the synchronizing signals.

Table 2-1 Video parameters for the standard display

Parameter	Value
Dot clock	30.24 MHz
Dot time	33.07 ns
Line rate	35.00 kHz
Line time	28.57 μ s
Frame rate	66.67 Hz
Frame time	15.00 ms

Figure 2-3 Standard video timing

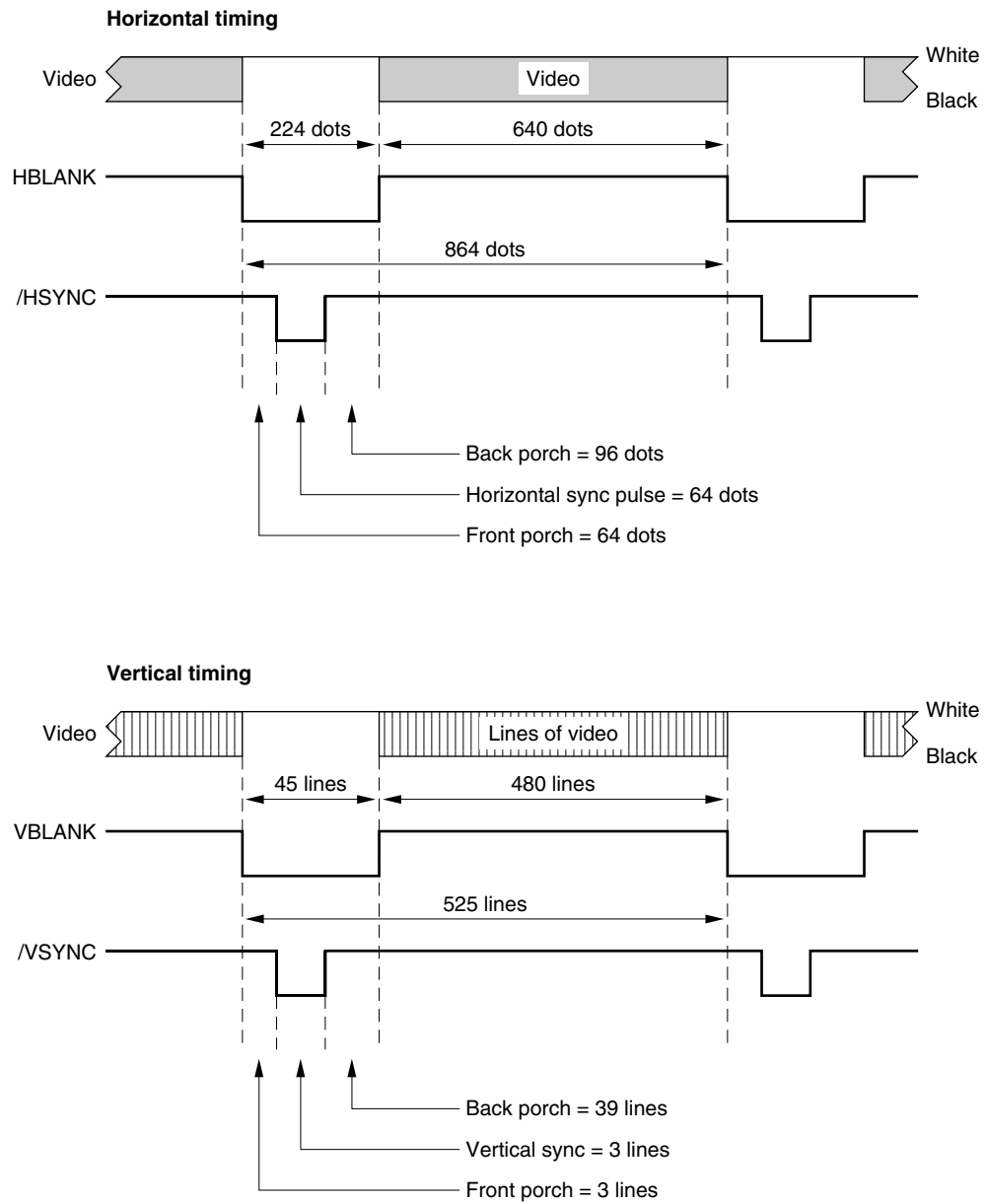

Architecture

When the Apple IIe Card for the Macintosh is installed in the expansion slot, the Macintosh LC 520 computer generates a 560-by-384-pixel video display. Table 2-2 lists the video parameters for the Apple IIe display and Figure 2-4 on page 28 shows the timing and synchronizing signals.

Table 2-2 Video parameters for the Apple IIe display

Parameter	Value
Dot clock	17.234 MHz
Dot time	58.02 ns
Line rate	24.48 kHz
Line time	40.85 μ s
Frame rate	60.15 Hz
Frame time	16.63 ms

Figure 2-4 Video timing for the Apple IIe card

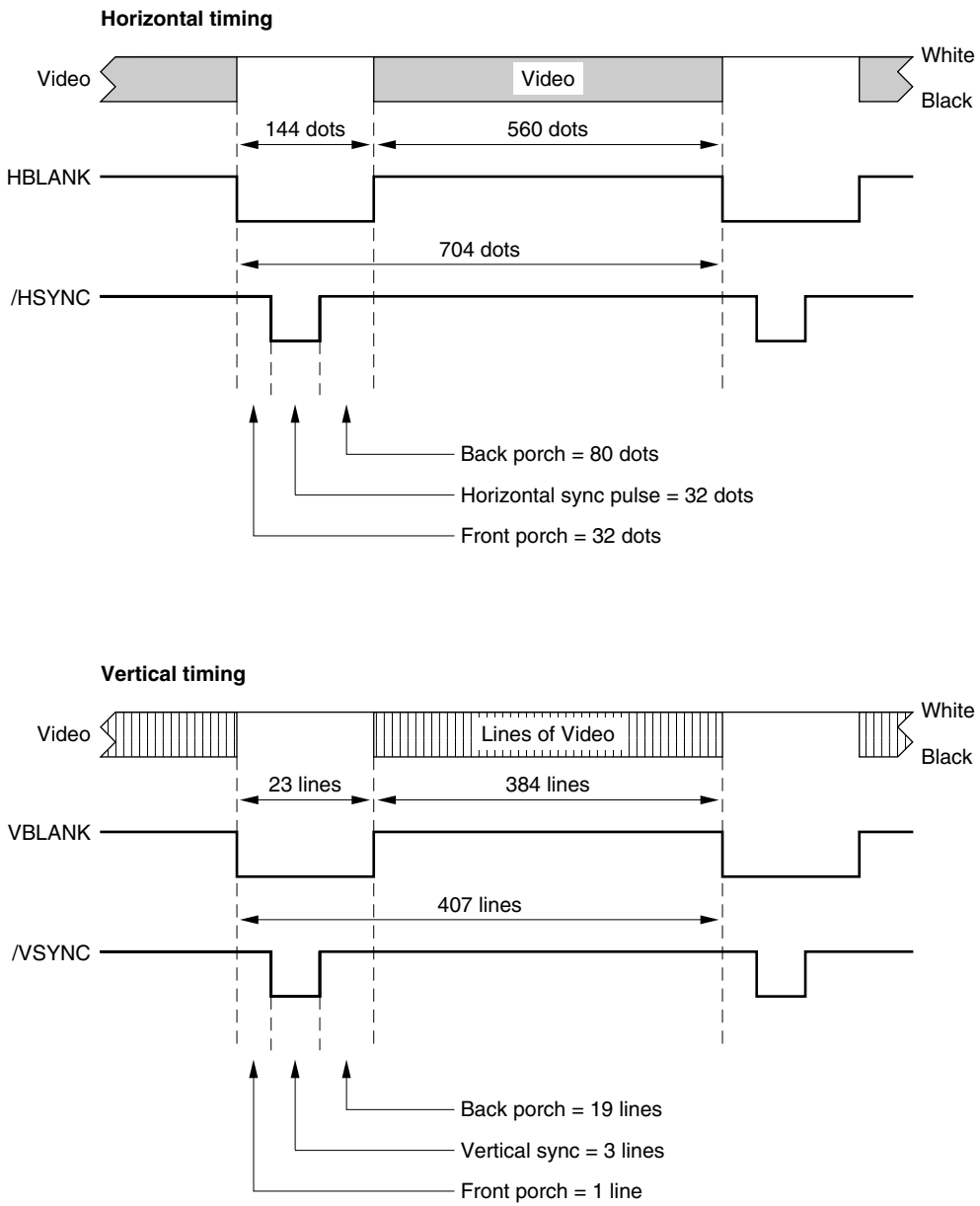

Expansion

Expansion

The expansion feature of the Macintosh LC 520 computer is a processor-direct slot that connects directly to the MC68030 microprocessor. This chapter describes the expansion slot and gives the specifications for an expansion card.

Expansion Slot

The expansion slot in the Macintosh LC 520 computer is an extended processor-direct slot that accepts either of two types of PDS cards: the 96-pin PDS card used in the Macintosh LC II computer or the 114-pin PDS card used in the Macintosh LC III. The 114-pin connector provides additional signals to support features of the MC68030 microprocessor that are not available with the 96-pin card.

Note

An expansion card designed for the Macintosh LC II computer will work in the Macintosh LC 520 computer if the card's designer has followed the guidelines in *Designing Cards and Drivers for the Macintosh Family*, third edition. ♦

The PDS expansion connector in the Macintosh LC 520 computer is mechanically the same as the expansion connector in the Macintosh LC III. It is essentially a 120-pin Euro-DIN connector with six pins removed to make a notch. The notch divides the connector into two sections: a 96-pin section that accepts the 96-pin connector used on expansion cards for the Macintosh LC II, and a separate 18-pin section for the additional signals.

Pin Assignments

Pins numbered 1–32 in rows A, B, and C correspond to the 96-pin section of the connector. Table 3-1 gives the pin assignments for the 96-pin section.

Except for one signal, 16MASTER (on pin B31 and described in Table 3-4), the pin assignments on the 96-pin section of the extended PDS are the same as those on the PDS in the Macintosh LC II. On the Macintosh LC II, pin B31 is the Apple II clock input.

Pins 33 and 34 in all three rows are missing—those pins correspond to the notch in the connector. Pins 35–40 in rows A, B, and C make up the 18-pin section of the extended connector. Table 3-2 on page 32 gives the pin assignments for the 18-pin section.

Note

Signal names starting with a slash (/) are active when their signal lines are driven to a logical zero (0). ♦

IMPORTANT

Under no circumstances should you use the Analog GND pin (Pin 1, Row B) for a digital ground on your expansion card. Doing so will cause digital noise to be coupled into the audio system, resulting in degraded sound quality. ▲

Expansion

Table 3-1 Signals on the 96-pin section of the expansion connector

Pin number	Row A	Row B	Row C
1	SNDOUT	Analog GND	/FPU.SEL
2	/SLOTIRQ	/R/W	/DS
3	/PDS.AS	+5V	/BERR
4	/PDS.DSACK1	+5V	/PDS.DSACK0
5	/HALT	SIZ1	SIZ0
6	FC2	GND	FC1
7	FC0	CLK16M	/RESET
8	RMC	GND	/SLOT.BG
9	D31	D30	D29
10	D28	D27	D26
11	D25	D24	D23
12	D22	D21	D20
13	D19	D18	D17
14	D16	D15	D14
15	D13	D12	D11
16	D10	D9	D8
17	/BGACK	/BR	A0
18	A1	A31	A27
19	A26	A25	A24
20	A23	A22	A21
21	A20	IPL2	IPL1
22	IPL0	D3	D4
23	D2	D5	D6
24	D1	D0	D7
25	A4	A2	A3
26	A6	A12	A5
27	A11	A13	A7
28	A9	A8	A10
29	A16	A15	A14
30	A18	A17	A19
31	n.c.	16MASTER	FC3
32	+12V	GND	-5V

Expansion

Table 3-2 Signals on the 18-pin section of the expansion connector

Pin number	Row A	Row B	Row C
35	A28	/CPU.BG	CPU.CLK
36	A29	CPU.TYPE	A30
37	/CIOUT	/CPU.AS	/STERM
38	/CBACK	/CPU.DISABLE	/CBREQ
39	/SLOTIRQ.D	/DSACK0	/SLOTIRQ.C
40	CACHE	GND	/DSACK1

All the signals on the expansion connector are capable of driving at least one TTL load (1.6 mA sink, 400 μ A source). Most of the signals are connected to other MOS devices on the main logic board; for those signals, the DC load on the bus signals is small. The high-order 16 data lines (D16–D31) have one LS load connected to them.

Descriptions of the Signals

Most of the signals on the expansion connector are connected directly to the signal of the same name on the MC68030 microprocessor. Table 3-3 describes the functions of those processor-direct signals. Table 3-4 gives the signal descriptions for the signals that are not connected to the MC68030.

Table 3-3 Processor-direct expansion connector signal descriptions

Signal name	Signal description
A0–A31	Address lines.
/BERR	Bus error; bidirectional signal indicating that invalid bus operation is being attempted.
/BGACK	Bus grant acknowledge; input signal indicating that external device has become bus master.
/BR	Bus request; input signal indicating that external device is requesting to become bus master.
/CBACK	CPU burst acknowledge; used with /STERM during a burst transfer to indicate that individual elements of a burst transfer are ready.
/CBREQ	CPU burst request; used to initiate a quadruple longword burst transfer.
/CIOUT	Cache inhibit out signal from main processor, indicating that a second-level cache is allowed to participate in the current bus transaction.
/CPU.AS	Processor's address strobe; three-state output signal indicating that an active bus transaction is occurring.

continued

Expansion

Table 3-3 Processor-direct expansion connector signal descriptions (continued)

Signal name	Signal description
/CPU.BG	Processor bus grant; signal from the external device can become bus master following completion of current processor bus cycle.
D0–D31	Data lines.
/DS	Data strobe. During read operation, /DS indicates that external device should place data on data bus; during write operation, /DS indicates that the main processor has placed valid data on the data bus.
/DSACK0, /DSACK1	Data transfer acknowledge signals; indicate completion of data transfer operation from main processor; inform the processor of the size of the data port.
FC0–FC2	Function code used to identify address space of current bus cycle.
/HALT	Signal indicating that main processor should suspend all bus activity.
IPL0–IPL2	Interrupt priority-level lines.
/RESET	Bidirectional signal that initiates system reset.
RMC	Three-state output signal that identifies current bus cycle as part of indivisible read-modify-write operation.
/R/W	Read/write; three-state output signal that defines direction of bus transfer with respect to the main processor.
SIZ0–SIZ1	Three-state output signals that work in conjunction with processor's dynamic bus sizing capabilities to indicate number of bytes remaining to be transferred during current bus cycle.
/STERM	Connected to the /STERM signal on the main processor; indicates termination of a transfer using the MC68030 synchronous cycle.

Table 3-4 Expansion slot signals not connected to the MC68030

Signal name	Signal description
CACHE	Signal from the card, indicating that the current bus transaction can be satisfied by the external cache on the card.
CLK16M	Independent clock running at 15.6672 MHz; provided for compatibility with Macintosh LC and LC II PDS cards.
CPU.CLK	Main processor clock (25.0 MHz).
/CPU.DISABLE	Disables the MC68030 CPU (and MC68882 FPU, if installed) on the main logic board. This signal is used by a PDS card that replaces the main processor.
CPU.TYPE	Defines bus protocol for the PDS; logical one (1) for MC68020 and MC68030, logical zero (0) for MC68040.
FC3	Additional function code bit, used to indicate that the software is running in 32-bit address mode. (As in the Macintosh LC II, the software always runs in 32-bit mode.)

continued

Table 3-4 Expansion slot signals not connected to the MC68030 (continued)

Signal name	Signal description
/FPU.SEL	Select signal for an optional MC68881 or MC68882 FPU on the card.
/PDS.AS	Address strobe synchronized to 16 MHz regardless of the actual processor speed; used to indicate the occurrence of an active bus transaction. /PDS.AS is asserted only when a valid slot address is being generated by the bus master or by an access to the FPU. Slot addresses are in the slot \$E range (\$xxExxxxx in 24-bit mode, \$FExxxxxx or \$Exxxxxx in 32-bit mode). When a PDS card is the active bus master, the card may drive either /PDS.AS or /CPU.AS, but not both.
/PDS.DSACK0, /PDS.DSACK1	Data transfer acknowledge signals from the PDS card.
16MASTER	Indicates the width of the data port when the card is alternate bus master. A logical one (1) indicates a 16-bit port; logical zero (0) indicates a 32-bit port. The signal is pulled high on the main logic board.
/SLOT.BG	Bus grant signal to the expansion card. A bus master card may take control of the system bus after all pending bus traffic has been completed (when /PDS.AS, /BGACK, and all /DSACK signals are inactive).
/SLOTIRQ	Interrupt request line from the card; reported to the system by way of the SLOTE request; when low, generates a level-2 interrupt if the slot interrupt enable bit is set.
/SLOTIRQ.C, /SLOTIRQ.D	For future expansion; not used in the Macintosh LC 520 computer.
SNDOUT	Input to the speaker amplifier so that the card can drive the speaker independently of the main processor. This signal accepts only sound output by the method used on the original Apple II, using 1's and 0's.

▲ **WARNING**

The SNDOUT pin must not be grounded; doing so will short-circuit the +5V power to the sound circuitry. If you don't use the SNDOUT pin, leave it unconnected. ▲

The PDS Expansion Card

The PDS expansion card for the Macintosh LC 520 computer is approximately 3 inches wide by 5 inches long. It mounts parallel to the main logic board and reaches to an opening in the back of the case (normally filled by a snap-out cover). The opening provides access to a 15-pin D-type connector on the card for external I/O.

The PDS card for the Macintosh LC 520 computer is the same size and shape as the PDS card for the Macintosh LC III computer. The section "Foldouts" at the end of this developer note contains mechanical drawings showing the recommended design guidelines for the PDS card. Foldout 1 shows the maximum dimensions of the expansion card and the location of the PDS connector. Foldout 2 provides component height

Expansion

restrictions for the expansion card. Foldout 3 shows how the card is installed on the main logic board.

Expansion Card Connectors

The custom 114-pin PDS connector on the computer's main logic board accepts either a 96-pin or 120-pin standard Euro-DIN connector. You can order connectors meeting Apple specifications from Amp Incorporated, Harrisburg, PA 17105 or from Augat Incorporated, Interconnect Products Division, P. O. Box 779, Attleboro, MA 02703. Refer to *Designing Cards and Drivers for the Macintosh Family*, third edition, for more information about those connectors.

Address Space for the Expansion Card

The expansion card's address space depends on the memory addressing mode. In 24-bit mode, the card appears in the address space \$E0 0000–\$EF FFFF; in 32-bit mode, the card appears in the address space \$8000 0000–\$FFFF FFFF. To match the conventions used by the Slot Manager, software should address the card as if it were in slot space \$E: either the 16 MB slot space \$FE00 0000–\$FEFF FFFF or the super slot space \$E000 0000–\$EFFF FFFF.

The expansion card must generate its own select signal from the address and function code signals on the connector. The card select signal must be disabled when FC0, FC1, and FC2 are all active; that condition corresponds to a function code of 111 (CPU space). Figure 3-1 shows a typical logic circuit for generating the card select signal.

Figure 3-1 Generating the card select signal

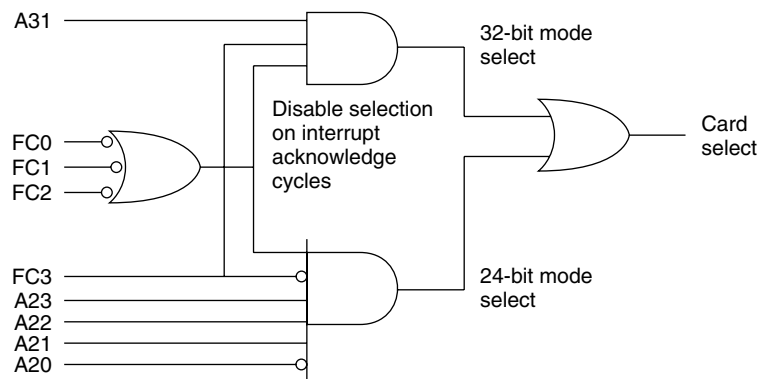

IMPORTANT

To ensure compatibility with future hardware and software, you should minimize the chance of address conflicts by decoding all the address bits. To ensure that the Slot Manager recognizes your card, the card's declaration ROM must reside at the upper address limit of the 16 MB address space (\$FE00 0000–\$FEFF FFFF). ▲

Expansion

Power for the Expansion Card

The PDS card uses power supplied through the 96-pin connector. The maximum current available at each supply voltage is shown in Table 3-5. The card must not dissipate more than 5 W total; for example, if the card uses the maximum current at -5 V and +12 V, it must not use more than 500 mA from the +5 V supply.

Table 3-5 Power available for the expansion card

Voltage	Current
+5	1.0 A
-5	20 mA
+12	200 mA

▲ **WARNING**

Cards dissipating more than 5 watts may overheat and damage the Macintosh LC 520 computer's circuitry or cause it to become inoperable. ▲

Software

Software

The first part of this chapter describes the software in the Macintosh LC 520 computer's ROM. The second part describes the system software that supports the new features of the Macintosh LC 520 computer.

ROM Software

The ROM in the Macintosh LC 520 computer is based on the ROM for the Macintosh LC III with the necessary changes to support machine-specific hardware.

Unchanged Functions

Many ROM software components in the Macintosh LC 520 computer are functionally the same as their counterparts in the Macintosh LC III. Those components are

- the Slot Manager
- network booting routines
- Color QuickDraw
- floating-point arithmetic routines
- SANE routines

The AppleTalk routines are no longer in the ROM; they are now in the system software, but they are similar to their counterparts in the ROM in the Macintosh LC III.

MMU Initialization

The code has been modified to support the memory addressing used by the Macintosh LC 520 computer. There are new MMU tables to match the address mapping.

Machine Identification

The ROM includes new tables and code for identifying the machine.

Applications can find out which computer they are running on by using the Gestalt Manager routines; see *Inside Macintosh*, Volume VI. The 'gestaltMachineType' value for the Macintosh LC 520 computer is 56 (hexadecimal \$38).

RAM Sizing and Addressing

The Macintosh LC 520 computer uses the same code as the Macintosh LC III for determining the size of RAM, for setting up the MMU to make the RAM addresses contiguous, and for address decoding.

To be able to run with virtual memory active, the Macintosh LC 520 computer uses the 32-bit Memory Manager and runs in 32-bit mode.

One-Second Interrupt

As on the Macintosh Color Classic and Macintosh LC III computers, the one-second interrupt on the Macintosh LC 520 computer is provided by the ADB microcontroller, which sends the one-second interrupt to the main processor as a pseudodevice transaction. In those cases where a one-second interrupt has been missed, the ADB microcontroller sends the current value of the real-time clock so that the system software can update the value stored in the `Time` global variable.

Pushbutton Interrupts

The ROM in the Macintosh LC 520 computer includes routines for initializing the pushbutton interrupt bits in the interrupt enable and flag registers and for initializing other new registers that support the pushbuttons.

Pushing any of the four pushbuttons on the front of the case causes the machine to set a bit in a new register, the Pushbutton register, which in turn causes a level-2 interrupt. The interrupt handler disables the pushbutton interrupt until the button that caused the interrupt is released.

Power Saver Software

The software that controls the brightness of the display also includes code that implements the power saver mode, which turns off the power to the display after a set interval of time. Applications can turn the monitor on and off and read its status by making the appropriate call to the Screen driver (`.BCScreen`). For more information, see the section “The Screen Driver” beginning on page 42.

Note

The screen can remain dark for several seconds after the screen is reactivated, so the system emits a series of beeps to reassure the user that the computer is still operating. The Screen driver call that turns the monitor back on also causes a call to the Notification Manager to play the `SysBeep` sounds. When the screen is being reactivated, the keyboard and mouse are disabled until the screen reappears. ♦

Video Software

Video support on the Macintosh LC 520 computer uses the same code as that used in the Macintosh LC III computer. The only difference is that VRAM is always present in the Macintosh LC 520.

System Software

The Macintosh LC 520 computer requires System 7.1 or a later version of system software. The disk labeled “Install Me First” includes a system enabler file that contains the resources the system needs to start up and initialize the Macintosh LC 520 computer.

The system disk includes an Installer application to install the control panels for the new features of the machine.

System Enabler

Starting with the international release of System 7.1, each reference release of the Macintosh system software supports a new startup extension, the system enabler. The **system enabler** is a software resource that is able to perform the correct startup process for one or more Macintosh computers.

As soon as the system software on disk takes over the startup process, it searches for all system enablers that can start up the particular machine. Each system enabler contains a resource that specifies which computers it is able to start up and the time and date of its creation. If the system software finds more than one enabler for the particular computer, it passes control to the one with the most recent time and date.

In general, the system enabler included in each reference release of system software is able to start up all previous computers. The system enabler that accompanies a later computer will be able to start up that computer, possibly using resources from the previous reference release.

Booting From a CD-ROM

The Macintosh LC 520 computer can start up (boot) from a built-in CD-ROM drive. Starting up in this fashion is not recommended, because the system software was not designed to operate from a locked storage device—one that the software can't write to. The system software that Apple Computer uses on the system CD-ROM includes only one control panel file—for setting the startup disk—along with Installer software to install the system onto a hard disk. Developers may wish to use a similar arrangement to distribute bulky software.

New Control Panels

The system software for the Macintosh LC 520 computer includes new control panels for the sound level and the screen brightness and contrast.

Software

Sound Control Panel

The Sound control panel on the Macintosh LC 520 computer is able to update its slider to reflect changes in the sound level caused by the user pressing one of the sound pushbuttons on the front of the case. The control panel also has a Mute checkbox to turn off the sound. When the user adjusts the sound level, either with the control panel or with the pushbuttons, the software also turns off the Mute checkbox. Figure 4-1 shows the Sound control panel.

Figure 4-1 Sound control panel

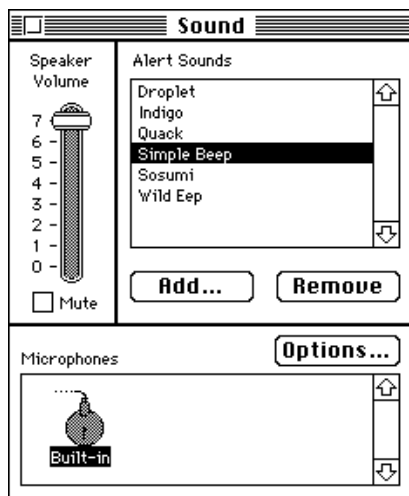

The Sound control panel also allows the user to select the source of sound input, which can be either the built-in microphone or a device plugged into the sound input jack. When the user clicks the Options button, a dialog box appears, as shown in Figure 4-2. The user can then select either the internal microphone, an external microphone, or the line-level inputs.

Either the external microphone or line-level inputs can be plugged into the sound input jack. When the user selects the corresponding input device in the Sound control panel, the computer sets the gain appropriately.

Figure 4-2 Sound options

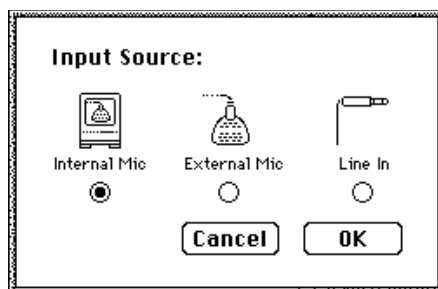

Software

Screen Control Panel

The Screen control panel has sliders for adjusting brightness and contrast. The user can adjust either slider by dragging with the mouse and can adjust the contrast using the arrow keys or the number keys. Figure 4-3 shows the Screen control panel.

Figure 4-3 Screen control panel

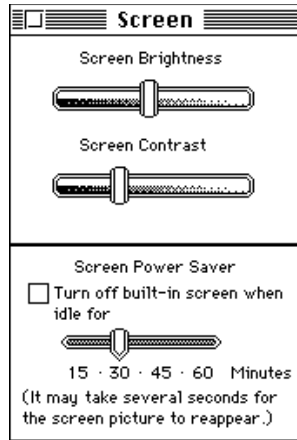

Note

The Screen control panel uses minimum and maximum values supplied by the Screen driver so as not to set the screen so dark that the user cannot see the control panel to make further adjustments. ◆

The Screen Driver

Applications can read and set the brightness and contrast of the screen by making appropriate status and control calls to the Screen driver (.BCScreen). The system startup code uses the Screen driver to set the initial screen values.

The current values of brightness and contrast are stored as byte values in parameter RAM. If the startup software finds a value below the minimum startup value, it sets it to a default midrange value.

IMPORTANT

The Screen Driver is machine specific; it does not support all Macintosh models. ▲

Screen Driver Calls

Screen driver calls use the `ParamBlockRec` method as described in the Device Manager chapter of *Inside Macintosh*. The parameter passing conventions are the standard ones: the calling program passes a pointer to the parameter block in register A0.

Software

Because the Screen driver is opened at startup and is never closed, and because there is nothing to read or write, the following calls are not supported:

- CloseDriver
- FSRead
- FSWrite
- KillIO

The following are calls supported by the Screen Driver.

Open

PBOpen (paramBlock: ParmBlkPtr; async: BOOLEAN) : OSErr_Open

Parameter block

→	ioCompletion	Nil.
←	ioResult	noErr (zero).
→	ioNamePtr	Pointer to the name .BCScreen.
←	ioRefNum	Driver's reference number.
→	ioPermsn	Must be fsCurPerm.

When the system software opens the Screen driver at startup time, the Device Manager creates a device control entry (DCE) and stores its handle in the proper unit table entry. Subsequent Open calls merely return refNum and a result (noErr). Programs can use the Open call to obtain the refNum value for use in control and status calls.

High-level call:

OpenDriver (name: Str255; VAR refNum: INTEGER) : OSErr

Control

PBControl (paramBlock: ParmBlkPtr; async: BOOLEAN) : OSErr_Control

Parameter block

→	ioCompletion	Nil.
←	ioResult	controlErr (-17) if csCode is unimplemented; otherwise noErr (0).
→	ioRefNum	Driver's reference number.
→	csCode	Identifies the call; described below.
→	csParam	Depends on the call; described with the csCode values where it is used (csParam is an array of 11 shorts).

Software

csCode values:

Name	Value	Description
CtrlScrnBright	\$4301	Set screen brightness PWM value to csParam[0] (value = 0-255).
CtrlSaveBright	\$4302	Store current brightness to PRAM.
CtrlScrnCont	\$4307	Set screen contrast PWM value to csParam[0] (value = 0-255).
CtrlSaveCont	\$4308	Store current contrast to PRAM.
CtrlScreenOff	\$4309	Turn off power to internal monitor.
CtrlScreenOn	\$4310	Turn on power to internal monitor.

High-level call:

```
Control(refNum: INTEGER; csCode: INTEGER; csParamPtr: Ptr) : OSerr
```

Status

```
PBStatus (paramBlock: ParmBlkPtr; async: BOOLEAN) : OSerr_Status
```

Parameter block

→	ioCompletion	Nil.
←	ioResult	controlErr (-17) if csCode value is unimplemented; otherwise, noErr (0).
→	ioRefNum	Driver's reference number.
→	csCode	Identifies the call; described below.
→	csParam	Depends on the call; described with the csCode values where it is used (csParam is an array of 11 shorts).

csCode values:

Name	Value	Description
StatScrnBright	\$5301	Return current screen brightness in csParam[0] (value = 0-255).
StatBrtMinMax	\$5303	Return minimum and maximum brightness values: csParam[0] = maximum brightness, csParam[1] = minimum brightness.
StatScrnCont	\$5307	Return current screen contrast in csParam[0] (value = 0-255).
StatConMinMax	\$5308	Return minimum and maximum contrast values: csParam[0] = maximum contrast, csParam[1] = minimum contrast.
StatScrnOnOff	\$5309	Return state of internal monitor in csParam[0]: \$00FF = monitor power is on, \$0000 = monitor power is off.

High-level call:

```
Status(refNum: INTEGER; csCode: INTEGER; csParamPtr: Ptr) : OSerr
```

Internal Storage Devices

Internal Storage Devices

This chapter describes the internal storage devices in the Macintosh LC 520 computer. The computer accommodates one floppy disk drive, one half-high hard disk, and an optional AppleCD 300i CD-ROM drive.

IMPORTANT

This chapter describes the internal storage devices in the Macintosh LC 520 computer, but does not include design guides for developers. Because the front drive bezel does not include a separate component for the CD-ROM drive, and because the internal drives are specially modified to permit slide-in mounting, Apple Computer, Inc., does not recommend that developers provide internal storage devices for the Macintosh LC 520 computer. ▲

Storage Device Slide-In Bays

The hard disk drive, floppy disk drive, and optional CD-ROM drive slide into their respective mounting bays in the computer chassis. Connections to each drive are made by one or more connector adapters that fit onto the connector pins on the drive. When you slide a drive into its bay, the connector adapter fits into a matching socket at the back of the bay. Figure 5-1 shows how the AppleCD 300i CD-ROM drive slides into its bay in the front of the computer. The other internal storage devices are installed in much the same way, except that the bay for the hard disk drive is in the back of the computer, behind the removable back cover.

Figure 5-1 Installation of the internal CD-ROM drive

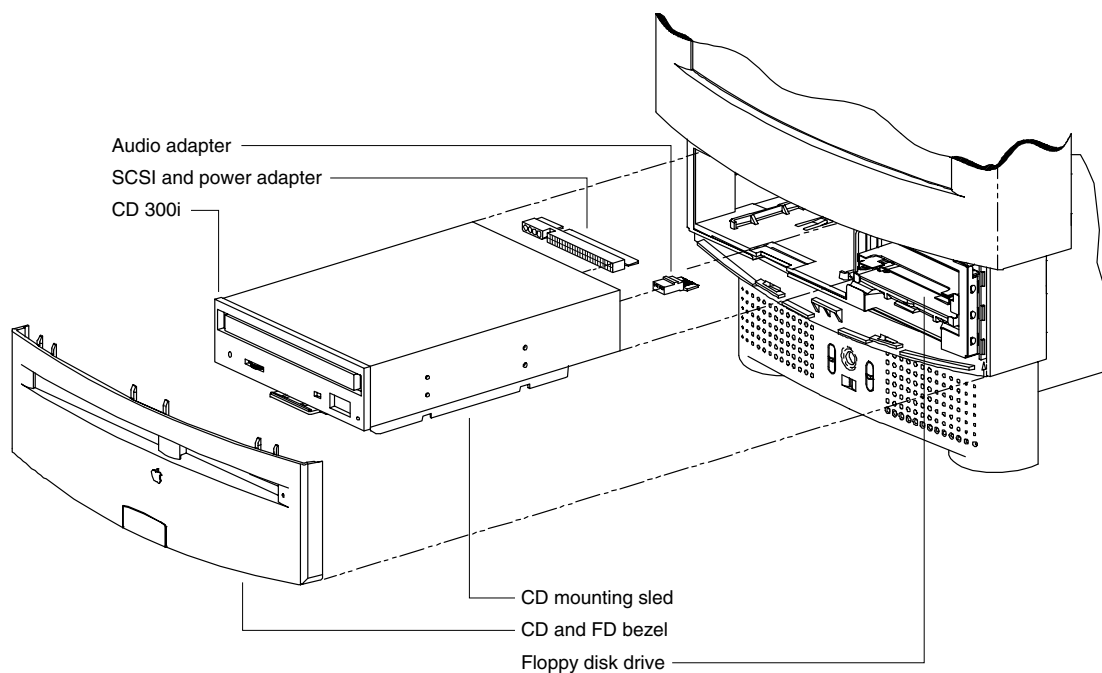

Front Drive Bezel

The front drive bezel has openings for access to removable media. On computers with no internal CD-ROM drive, the bezel has only the opening for floppy disks. Figure 5-2 shows the two views of the front drive bezel for the Macintosh LC 520 computer with the AppleCD 300i internal CD-ROM drive.

Note

To remove the front drive bezel, insert a flat screwdriver into the slot on the bottom of the bezel and twist while sliding the bezel downwards. ♦

Figure 5-2 Front drive bezel

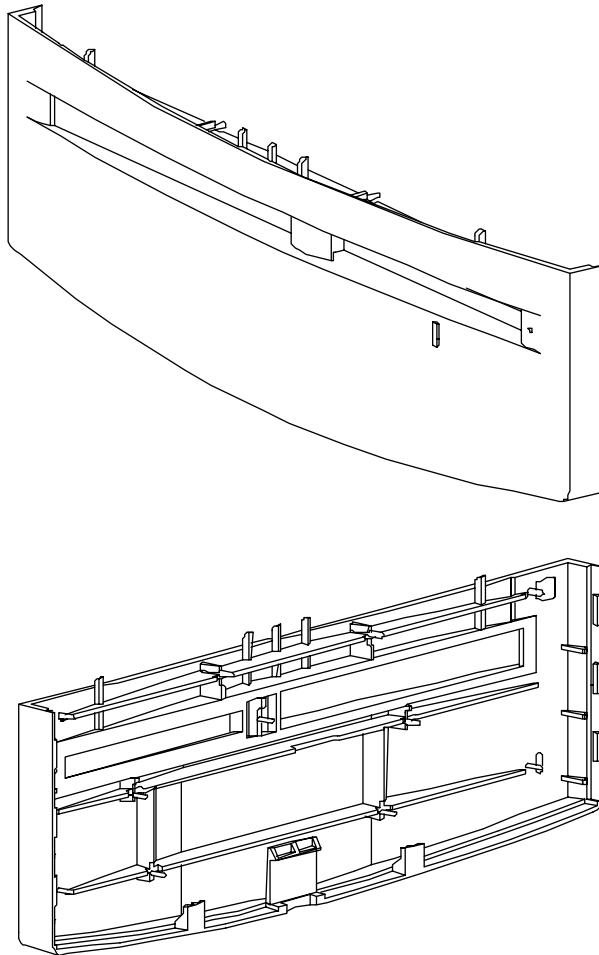

Connector Adapters

As Figure 5-1 illustrates, the Macintosh LC 520 computer uses special adapters that allow internal storage devices to slide into place and plug directly into the computer. The connectors on the devices themselves must be located properly so that the connector adapters will fit. Figure 5-3 shows the connector locations on the internal CD-ROM drive. Figure 5-4 shows the connector locations on the internal hard disk drive.

The internal hard disk uses a single connector adapter that incorporates both the signal pins and the power pins. The optional CD-ROM drive uses two connector adapters. The first of those is similar to the hard disk adapter and incorporates both signal and power pins. The second adapter is for the separate audio connector.

Figure 5-3 Connector locations on the CD-ROM drive

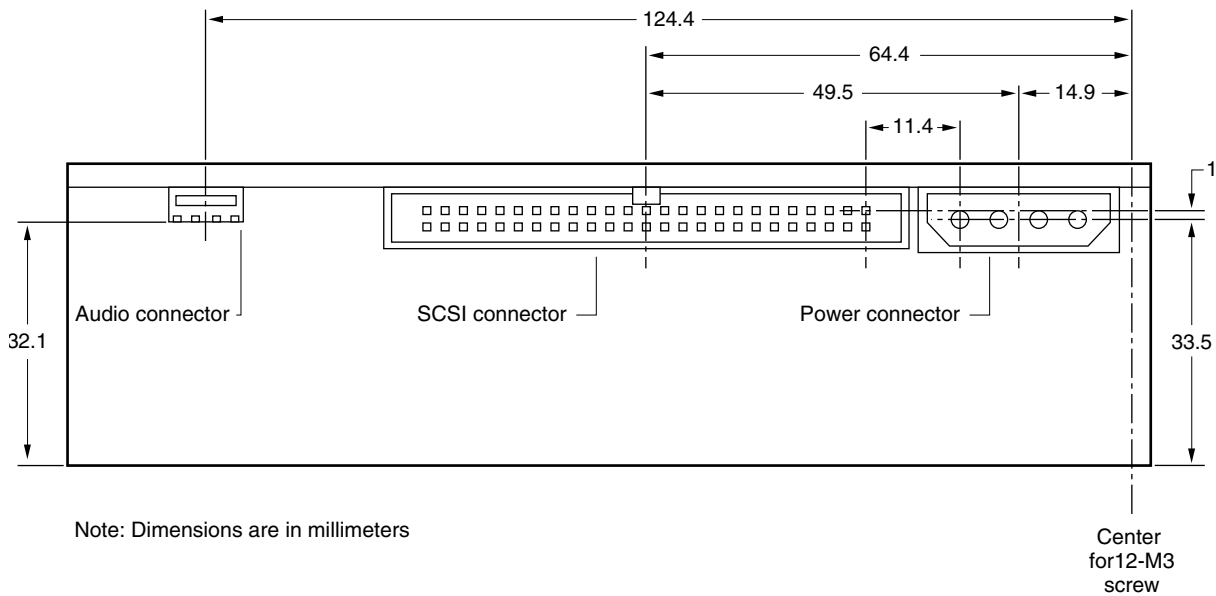

Internal CD-ROM Drive

This section describes the dimensions, mounting method, and power budget for the AppleCD 300i CD-ROM drive installed in the Macintosh LC 520 computer.

Dimensions of the CD-ROM Drive

Figure 5-5 shows the dimensions of the AppleCD 300i CD-ROM drive. The Appendix gives the other specifications of the AppleCD 300i.

Internal Storage Devices

Figure 5-4 Connector locations on the hard disk drive

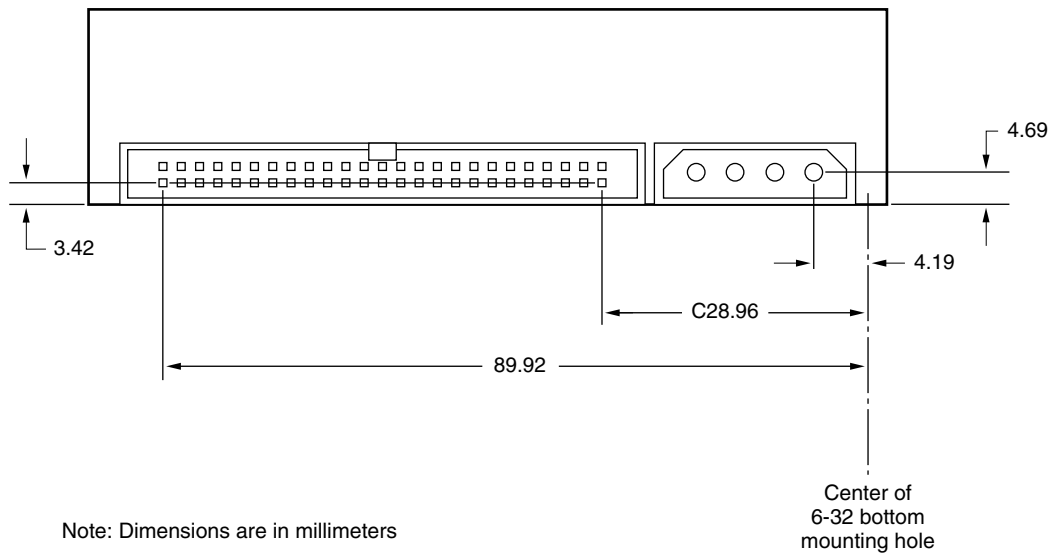
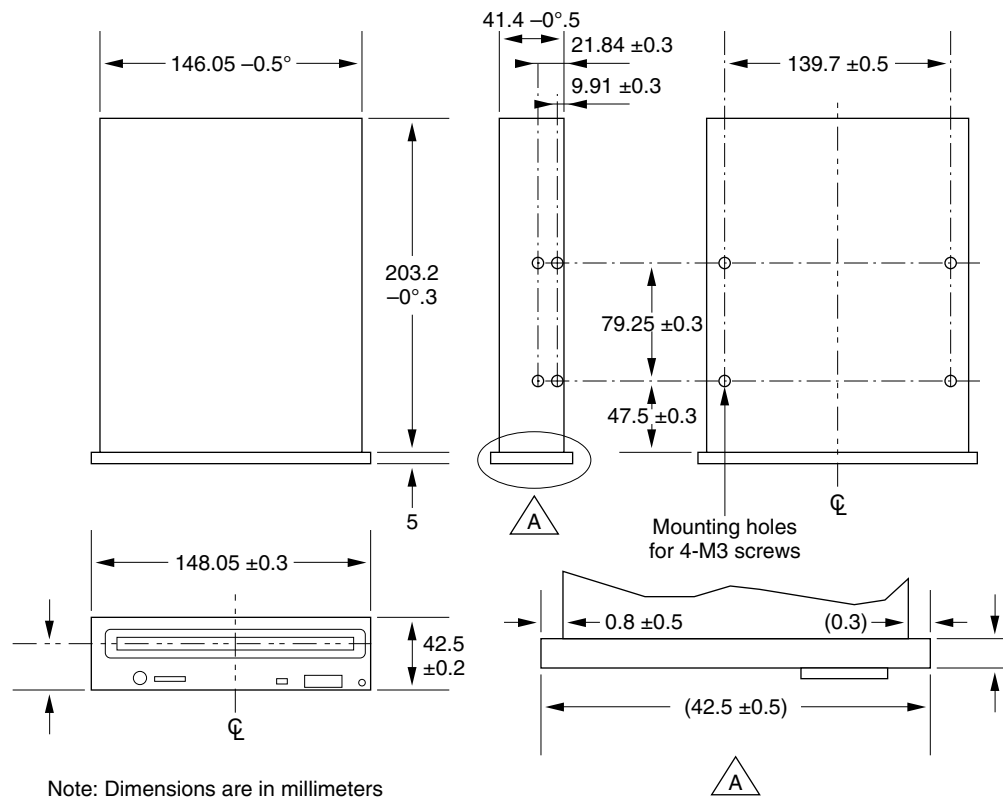

Figure 5-5 Dimensions of the CD-ROM drive



Mounting Method for the CD-ROM Drive

Figure 5-6 shows the AppleCD 300i CD-ROM drive mounted on the sled that secures it in the mounting bay. The sled is included in the AppleCD 300i mounting kit for the Macintosh LC 520 computer.

Figure 5-6 The AppleCD 300i mounted on the sled

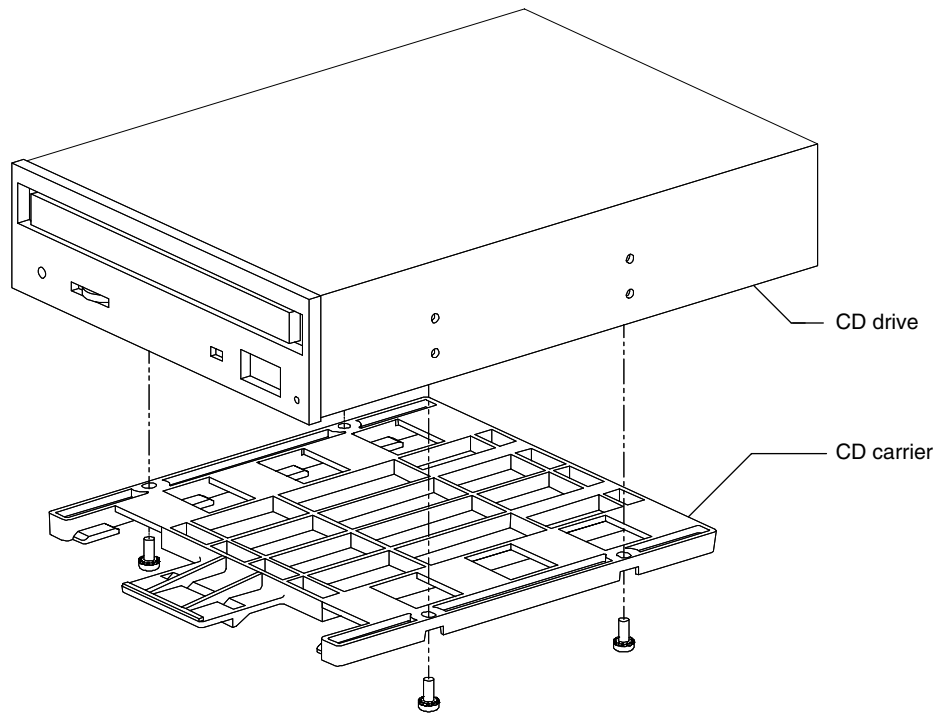

Power for the CD-ROM Drive

Table 5-1 shows the power budget for the AppleCD 300i CD-ROM drive in the Macintosh LC 520 computer.

Table 5-1 Power available for the AppleCD 300i CD-ROM drive

Voltage	Current
+5	500 mA max.
+12	800 mA max., 1.5 A peak (300 ms, 50% duty cycle)

Internal Storage Devices

Note

The AppleCD 300i CD-ROM drive connects to the internal SCSI bus. The drive does not have a SCSI terminator, because the internal SCSI bus is terminated in the built-in hard disk. ♦

Internal CD-ROM Integration

Apple's internal CD-ROM drive uses SCSI ID number 3.

Audio from the CD-ROM is connected to the computer by a separate connector adapter. Figure 5-7 shows the pin assignments. Each channel has its own ground return; the computer's audio circuits have differential inputs. The maximum signal level for the audio is $0.7 \text{ V} \pm 0.1 \text{ V RMS}$ at $47 \text{ K}\Omega$.

Figure 5-7 Pins on the CD-ROM audio connector

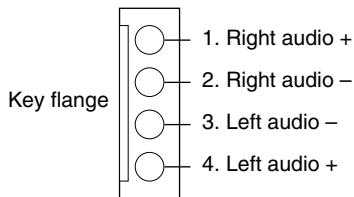

AppleCD 300i Specifications

This Appendix describes the performance and capabilities of the AppleCD 300i drive, the internal CD-ROM drive included in some configurations of the Macintosh LC 520 computer.

General Information

The AppleCD 300i supports the world wide standards and specifications for CD-ROM and CD-digital audio discs described in the Sony/Phillips Yellow Book and Red Book. The drive can read CD-ROM, CD-ROM XA, CD-I, and PhotoCD discs as well as play standard audio discs.

For improved performance, the AppleCD 300i features a new double-speed mechanism that supports sustained data transfer rates of 300 KB per second—double the transfer rate of previous drives. A 256 KB buffer on the drive controller further enhances performance.

Specifications

Table A-1 lists the specifications and performance characteristics of the AppleCD 300i drive.

Table A-1 AppleCD 300i specifications

Physical

Depth (excluding bezel)	203.2 mm (8.00 in.)
Width	146.0 mm (5.75 in.)
Height	41.4 mm (1.63 in.)
Weight	1.25 kg (2.75 lb.)

General

Spin up time (maximum)	3 sec. (double speed), 2 sec. (normal speed)
Spin down time (maximum)	1.5 sec. (double speed), 1 sec. (normal speed)
Eject time (maximum)	7 sec. (double speed), 6.5 sec. (normal speed)

continued

Table A-1 AppleCD 300i specifications (continued)**CD-ROM**

Modes supported	CD-ROM (Mode 1 and Mode 2), CD-ROM XA (Mode 2, Form 1 and Form 2), and CD-I (Mode 2, Form 1 and Form 2)
Block lengths supported	
CD-ROM Mode 1	2048, 1024, and 512 bytes
CD-ROM Mode 2	2340, 2336, 1024, and 512 bytes
CD-ROM XA	2647, 2353, and 2336 bytes
Blocks per disc	336,150 (typical)
Data capacity	656 MB, Mode 1 748 MB, Mode 2
Address description	Minutes, seconds, frames
Transfer rate (sustained)	300 KB/sec., Mode 1 (double speed) 150 KB/sec., Mode 1 (normal speed) 342.2 KB/sec., Mode 2 (double speed) 171.1 KB/sec., Mode 2 (normal speed)
Blocks per second	150 (double speed), 75 (normal speed)
Access time (typical)	
Full stroke (first to last block)	520 ms (double speed), 550 ms (normal speed)
Random (block to block)	295 ms (double speed), 350 ms (normal speed)
Track to adjacent track	2 ms
SCSI transfer rate (burst)	1.5 MB/sec., Mode 1 and Mode 2, asynchronous 4 MB/sec., Mode 1 and Mode 2, synchronous
SCSI buffer memory	256 KB
Uncorrected error rate (maximum)	
ECC enabled (Mode 1)	< 1 bit error per 10^{-12} blocks read (double speed) < 1 bit error per 10^{-15} blocks read (normal speed)
ECC disabled (Mode 1 or Mode 2)	< 1 bit error per 10^{-9} blocks read (double speed) < 1 bit error per 10^{-12} blocks read (normal speed)
CD-audio	
Block lengths supported	2448, 2368, and 2352 bytes
Playing time	74 minutes, 42 seconds
Line output	0.7 volts RMS at 47 K Ω
Headphone output (front panel)	0.65 volts RMS at 32 Ω
Distortion	< 0.04 percent at 1 KHz
Signal to noise ratio	> 80 dB
Frequency response	5 Hz to 20 KHz

Index

Numerals

24-bit addressing 23
32-bit addressing 23, 38
68HC05 microcontroller 22

A

abbreviations xi to xii
access to the logic board 4
ADB (Apple Desktop Bus) ports 15
ADB controller 22
address maps 24
address modes 23
AppleCD 300i 48
 features 53
Apple IIe card 10
 video display for 27
Apple SuperDrive 12
Ardbeg custom IC 20, 22
automatic termination 11

B

bezel, for front drives 47
block diagram 21
booting from CD-ROM 40

C

carrier for CD-ROM drive 50
CD-ROM booting 40
CD-ROM drive 48
 audio signals from 51
 bezel for 47
 connector 48
 mounting sled for 50
 power for 50
 SCSI ID number 51
CD-ROM formats 53
clock speed 20

color lookup table (CLUT) 25
Combo IC 22
connector adapters 48
connectors
 ADB 15
 floppy disk 12
 for expansion card 35
 SCSI 10
 serial I/O 13
 sound input jack 16, 41
 sound output jack 22
Control call 43
control panels
 Screen 42
 Sound 41
custom ICs
 Ardbeg 20, 22
 Combo 22
 DFAC II 22

D

DFAC II custom IC 22

E

expansion card. *See* PDS card

F

features summary 2
floppy disk connector 12
floppy disk controller 20
FPU (floating-point unit) 20

G

Gestalt Manager 38
GPi (general-purpose input)
 signal 14, 22

H

hard disk, connector 48

I, J

internal storage devices, bezel for
 front drives 47
interrupts
 for the pushbuttons 39
 one-second 39

K, L

keyboard
 power key 6, 16
 reset and NMI functions 16

M, N

machine identification 38
master power switch 6
 location of 4
MC68030 microprocessor
 clock speed 20
 signals on PDS connector 32
microphone
 built-in 16
 connector for 16, 41
 power for 16

O

one-second interrupt 39
Open call 43

P, Q

parameter RAM 22
 PDS (processor-direct slot) 10, 34
 PDS card 34
 addresses 35
 card select signal 35
 compatibility with
 Macintosh LC II 30
 connector for 35
 design guidelines 35
 power, maximum 36
 signal loading 32
 PDS connector signals 32
 power, safe shutdown 6
 power button 6
 power for CD-ROM drive 50
 power for PDS card 36
 power key 6, 16
 power saver 7, 39
 power switch 6
 location of 4
 pushbutton interrupts 39
 Pushbutton register 39
 pushbuttons
 interrupts for 39
 location of 3
 screen control 5
 sound level 16

R

RAM
 address space 23
 configurations 8
 expansion 8
 RAM SIMM 8
 reactivating the screen 39
 removing the logic board 4

S

Screen control panel 42
 screen control pushbuttons 5
 Screen driver
 Control call 43
 Open call 43
 Status call 44
 SCSI, bus termination 10 to 12
 SCSI connector 10
 SCSI controller 22
 serial I/O controller 22
 serial I/O ports 13
 GPI signal on 22
 modem power 14
 sound
 filters 23
 input jack 16, 41
 microphone 16
 modes of operation 22
 output jack 22
 playthrough feature 22
 pushbuttons 16
 sample rates 23
 sound circuits 22
 Sound control panel 41
 sound input jack 16, 41
 sound output jack 22
 standard abbreviations xi to xii
 startup from CD-ROM 40
 Status call 44
 summary of features 2
 System 7.1 40
 system enabler 40
 system software 40

T, U

termination, of the SCSI bus 10 to
 12
 automatic 11

V, W, X, Y, Z

VIA registers 20
 video display
 for Apple IIe card 5, 27
 bits per pixel 6
 dimensions 5
 dimming by power saver 7
 intensity of 5
 timing 25
 VRAM 6
 video RAM. *See* VRAM
 virtual memory 38
 VRAM 25
 expansion 6
 SIMM 25
 VRAM data bus 25

Foldouts

UNLESS OTHERWISE SPECIFIED

OPTIONAL TOOLING HOLES; IF USED WITH STANDOFF REFER TO APPLE P/N 815-0308.

HOLE RECOMMENDED FOR STANDOFF. REFER TO APPLE P/N 815-0177.

CONNECTOR, STRAIGHT HEADER : 96-PIN, APPLE P/N 515-0860, COMPATIBLE W/ LC FAMILY 120-PIN, APPLE P/N 515-0861, COMPATIBLE W/ LCI) AND SUBSEQUENT VERSIONS.

SHIELD PLATE REQUIRED TO MAINTAIN INTEGRITY OF EMI/RFI SEAM. REFER TO APPLE P/N 062-0489.

DO NOT PLACE HOT COMPONENTS IN THIS AREA.

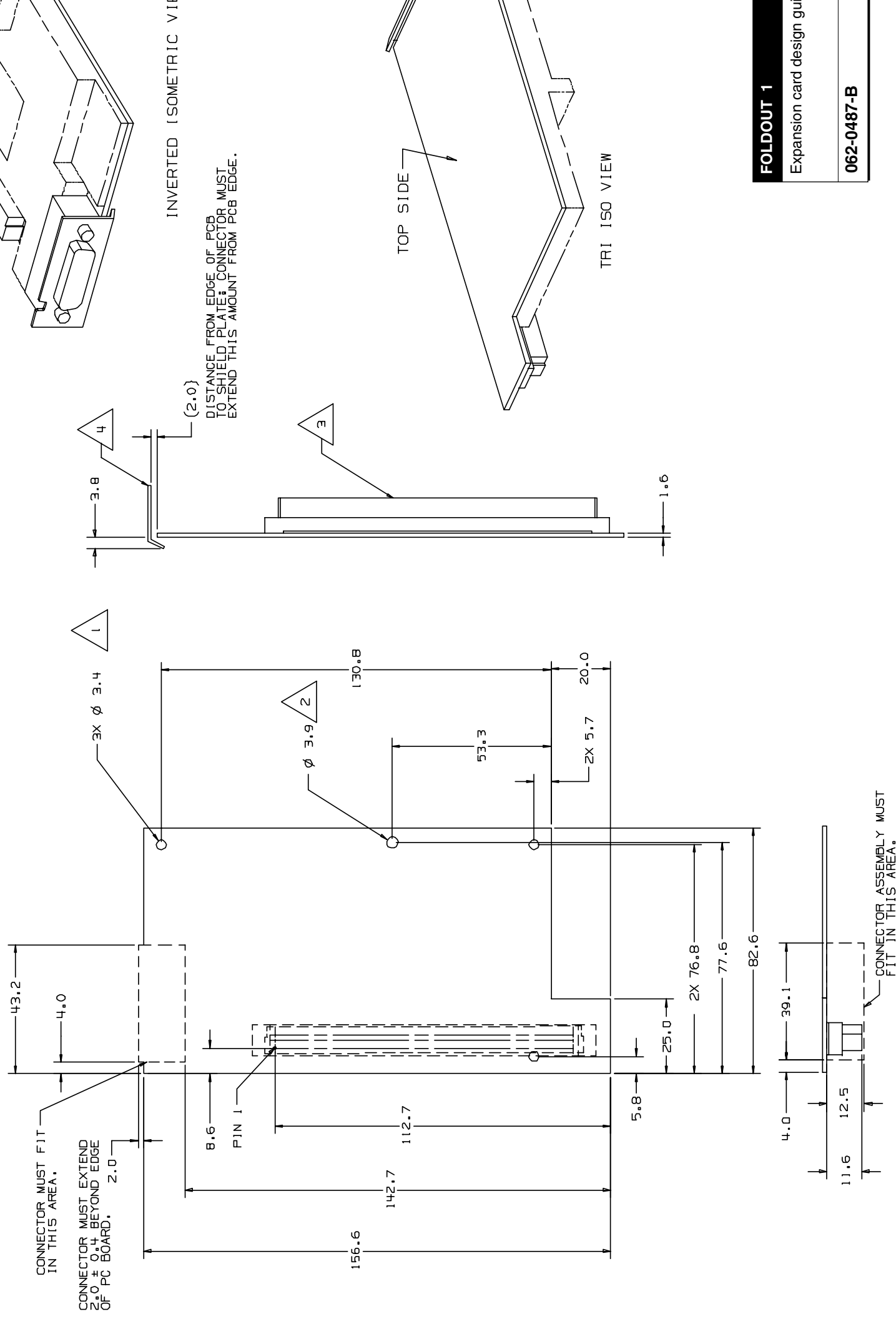

FOLDOUT 1

Expansion card design guide

062-0487-B

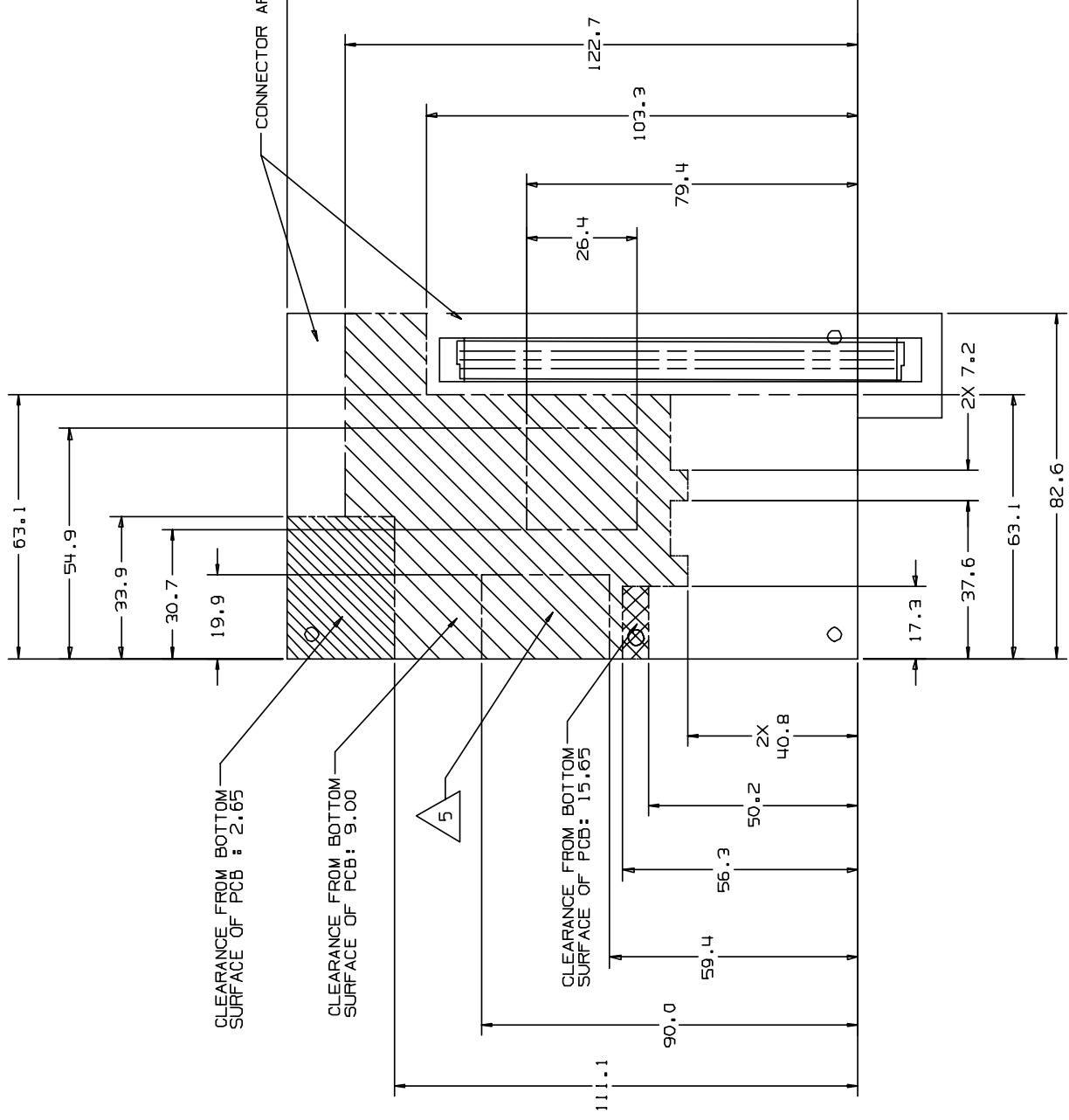

UNLESS NOTED CLEARANCE = 6.25MM

DETAIL **B**

BOTTOM SIDE
 COMPONENT HEIGHT RESTRICTION ZONES
 COMPONENT SIDE OF BOARD

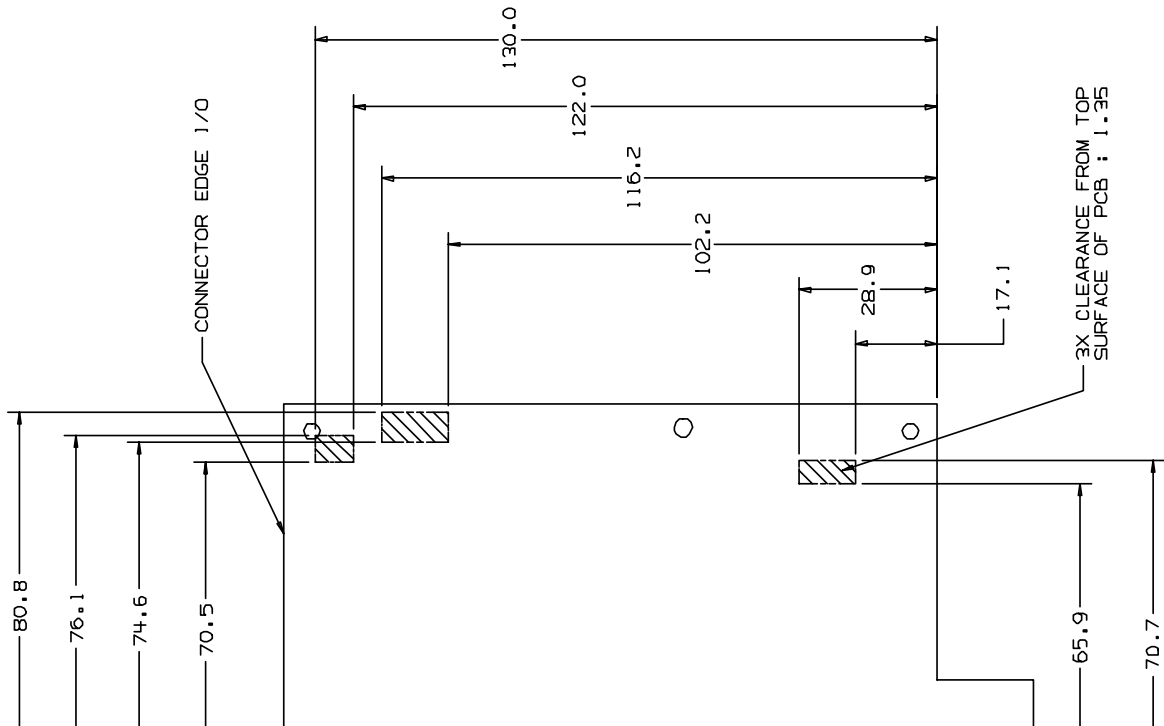

UNLESS NOTED CLEARANCE = 8.0

DETAIL **A**

TOP VIEW
 COMPONENT HEIGHT RESTRICTION ZONES
 SOLDER SIDE OF BOARD

FOLDOUT 2

Expansion card component

062-0487-B

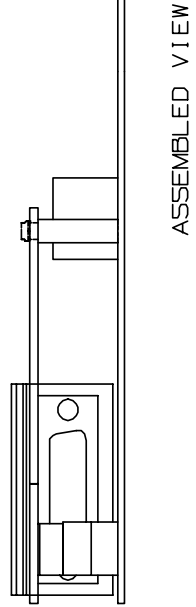
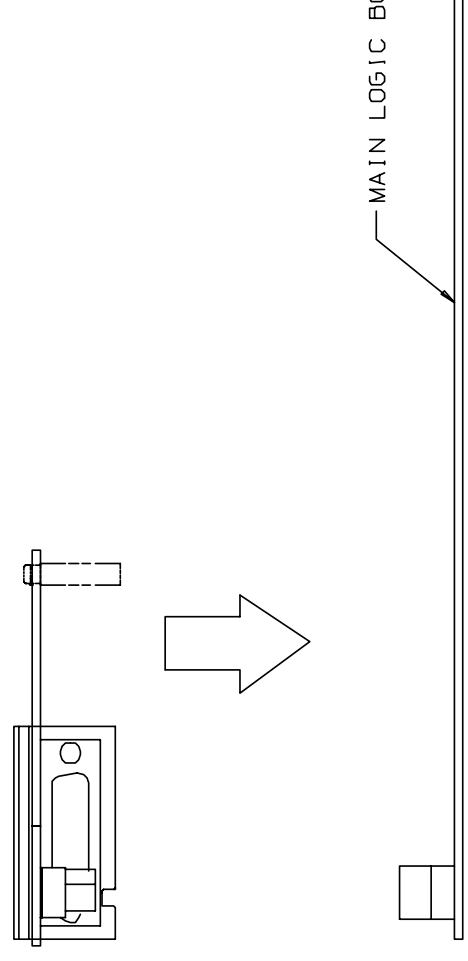
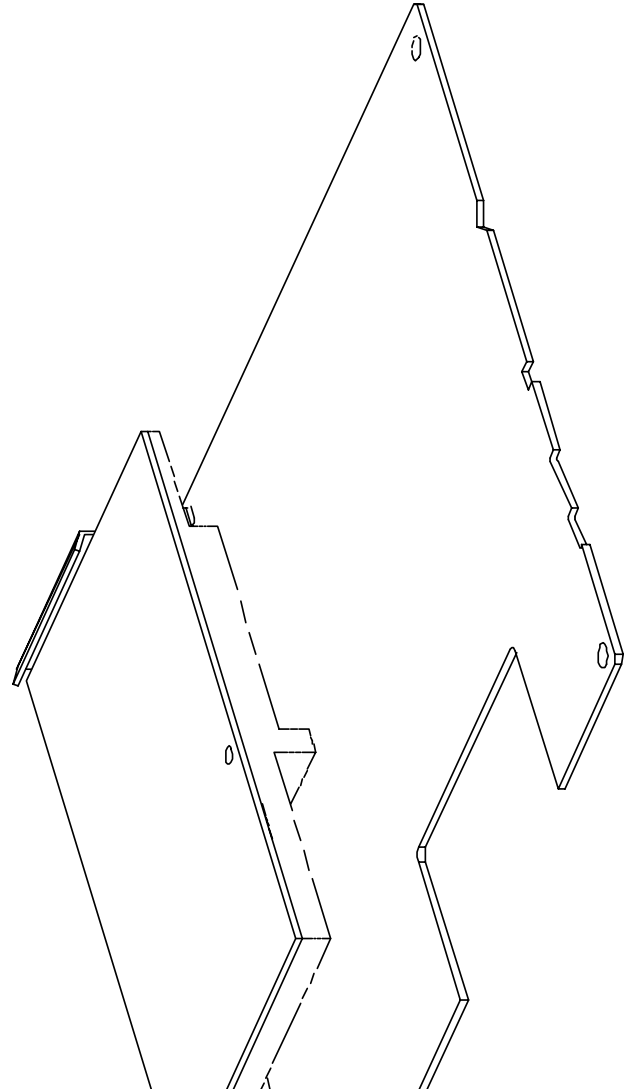
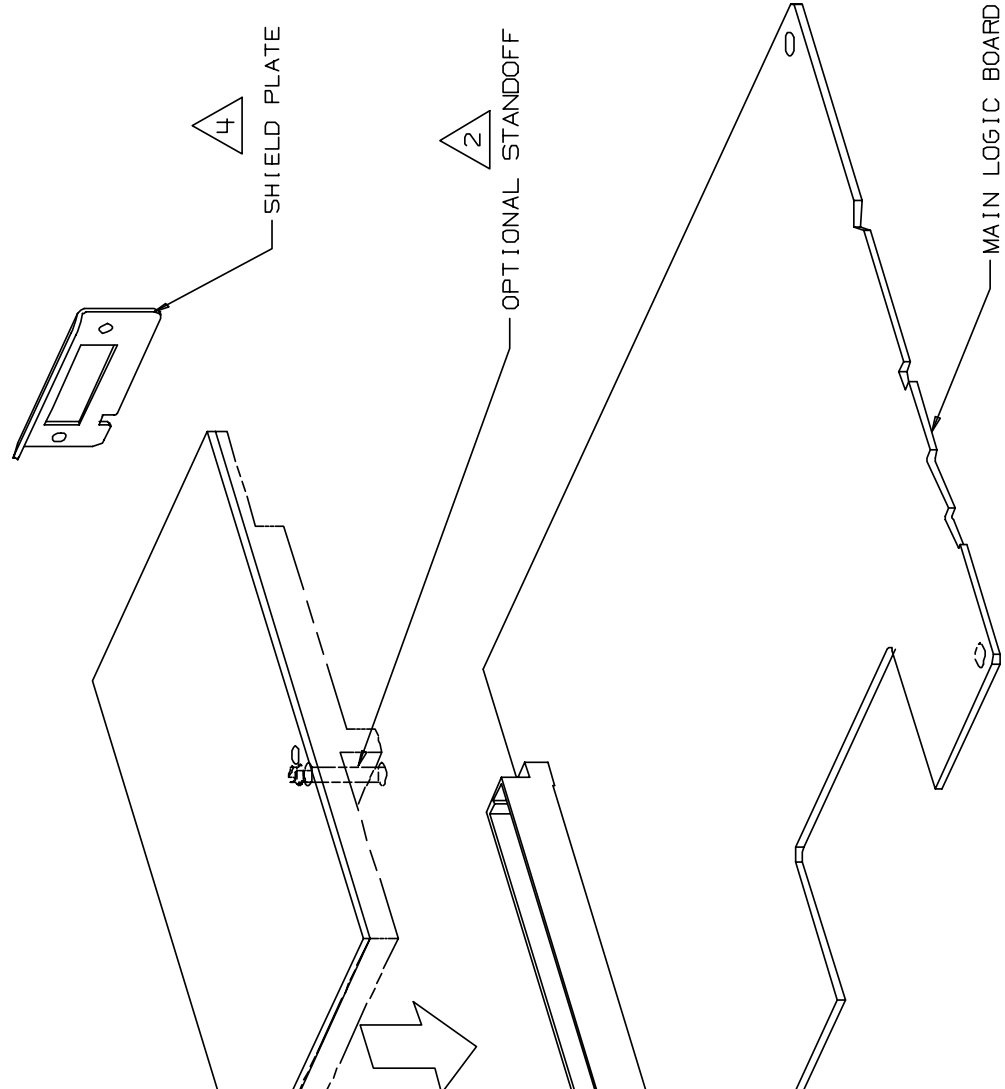

FOLDOUT 3

Expansion card assembly

062-0487-B