



A Scientific Games Company

Gun Smoke

Generic MPU4 Manual



This manual is intended primarily for the Field Service Engineer. The content is broadly based in an attempt to cover all machines using the MPU4 system. References made to some of the more detailed points may vary from model to model. The information is correct for the majority of cases but ideally should be used in conjunction with the individual information sheet supplied with each new machine.

The manual is divided into two parts. The first part provides the information necessary to operate the machine, providing it is functioning correctly. The second part provides the service information necessary to understand the workings and be capable of repairing the equipment when things go wrong.

If after consulting this manual troubles are still being experienced, please do not hesitate to contact our Technical Services Manager for further advice:

Technical Services Department,
Barcrest Limited,
William Street,
Ashton-under-Lyne,
Lancashire.
OL70RA
Telephone number: 061-3390212

WARNING

240voltsis presentwithinthe machine.Onlysuitablyqualifiedpersonnelshouldcarry out servicing.
Disconnectmainsleadbeforetouchingany internalcomponent.

The equipment to which this manual refers incorporates items protected by U.K. and Overseas patents.

CONTENTS

PART 1 OPERATIONAL INFORMATION

1.1	Siting	3
1.2	Supply Requirements	3
1.3	Installation	3
1.4	Initialisation	3
1.5	Self Test Routine	3
1.6	Demonstration and Testing.	4
1.7	Door Switches	4
1.8	Electro Mechanical Meters.	5
1.9	Electronic Meters	5
1.10	Option Switches	6
1.11	Volume Control	7
1.12	Refill.	7
1.13	Floating	7
1.14	Coil Level Detectors	7
1.15	Call Manager.	7
1.16	Linewriter	7
1.17	Reel Spin.	8

PART 2 SERVICE INFORMATION

2.1	MPU4 System	9
2.2	Interconnections	9
2.2.1	General.	9
2.2.2	I.D.C.Connectors	9
2.2.3	Main Harness Distribution Board	9
2.2.4	I.D.C. Lamp Connections	14
2.2.5	Replacing Glass on Machines fitted with I.D.C. Lampholders	14
2.3	Reel Assembly	14
2.3.1	General.	14
2.3.2	The Motor	14
2.3.3	The Reel Drum.	15
2.3.4	Motor Alignment	15
2.3.5	Photo Electrics	15
2.3.6	Symbol Illumination	20
2.3.7	Reel Bands	20
2.3.8	Reel Assembly Fixing	20
2.3.9	Reel Alarms.	20
2.4	Transformer and Power Supply	25
2.5	MPU4.	25
2.5.1	General.	25
2.5.2	MPU4 Fixing.	25
2.5.3	Lamp Drives	25
2.5.4	Switch Inputs	26
2.5.5	Triac Drives	26
2.5.6	Meter Drives	26
2.5.7	Seven Segment Display Drives	26
2.5.8	Stepper Motor Drives	26
2.5.9	Reel Photo Inputs.	26
2.5.10	Alpha Display Output	30
2.5.11	Aux Ports	30
2.5.12	Miscellaneous Connections	30
2.5.13	Dataport	30
2.5.14	Power In	30
2.5.15	Reset Circuit	30
2.5.16	Audio Circuit	32
2.5.17	Memory	32
2.6	The Program Module.	32
2.6.1	General	32
2.6.2	Program Module Identification	32
2.6.3	Program Modifications	32
2.6.4	Proms	34
2.6.5	Prom Replacement.	36
2.6.6	Characteriser	36
2.7	Fuses and Lamps.	36
2.8	Electronic Coin Mechanisms	36
2.9	Tube Level Detectors	36
2.10	Alarms	37
2.11	Fault Finding.	38
2.11.1	Measuring Voltages.	38
2.11.2	Component Substitution	38
2.11.3	Some Possible Problems and Possible Solutions	38
2.11.4	MPU4 Complete Pinout	39

OPERATIONAL INFORMATION

PART 1

1.1 SITING

The correct siting of any Fruit Machine is likely to reflect on its performance. The view and policies of the various interested parties will have a major influence on this decision and is clearly outside the scope of this manual. However in siting, the following points should be taken into consideration:

- i) The machine requires to be standing on a flat, level and stable floor.
- ii) Ensure the machine is remote from any source of heat, for example a radiator.
- iii) Avoid nylon carpets if resetting problems from static is to be avoided.
- iv) Mains plugs and sockets should be tight fitting and in good order.
- v) A good earth is necessary for safety and correct operation.
- vi) Machines look and perform best in subdued lighting.
- vii) The machine should be positioned where it can be supervised by the site staff.

1.2 SUPPLY REQUIREMENTS

Connection to the mains supply is through an I.E.C. Europlug at the rear of the machine.

The supply should be protected by a 3 amp fuse. In most installations this is achieved by the fuse rating of the 13 amp plug at the other end of the mains lead. A good earth is necessary if safety is to be assured and problems from static are to be avoided. The machine requires a nominal supply of 240V AC 50Hz but should easily tolerate a variation of plus or minus 10% (216 to 264 volts). If the supply is consistently low the transformer primary tap can be changed to 220V (see section 2.4).

However this change must be noted to ensure the tapping is returned to normal when the machine is resited. All machines supplied for export are fitted with a 3 amp mains filter and are tapped for 220V.

1.3 INSTALLATION

Installation procedure on an MPU4 based machine should include the following checks:

1. Running the self test routine. (See section 1.5).
2. Ensuring all coin mechanisms are accepting their intended coinage consistently and reliably.
3. Selecting the optimum setting for the volume control. (See section 1.11).
4. Ensuring option switch settings are suitable, (See section 1.10) to this siting.
5. Resetting electronic meters. (See section 1.9).
6. If "Linewriter" facility is available, ensuring any captions are appropriate for the site. (See section 1.16).

1.4 INITIALISATION

Each time the machine is powered up a number of automatic resetting and self checking procedures take place.

Except for a short time delay the observer is mostly unaware that these are taking place.

The machine will announce the fact it is "RESETTING" on the alphanumeric display together with the machine program number under which it is operating. After a short delay the reels spin about one revolution, reverse a few positions and stop. This is necessary to determine the current reel positions.

If this happens to correspond to a winning combination the reels will turn further to leave a losing combination on the payline. Finally, the alphanumeric display will give the full machine name, before the coin lockouts are energised and the machine becomes operational. Initialisation also takes place each time a machine door fitted with the appropriate sensing switch is opened or closed.

1.5 SELF TEST ROUTINE

All MPU4 machines have a self test facility, which provides an effective means of determining if the hardware is functioning correctly. The test mode is entered by first opening the machine's primary access door. After initialisation the alphanumeric display will read "*DOOR IS OPEN*". Pressing the TEST button located within the cabinet will result in the demonstration mode being entered, with 20 credits being displayed. If the TEST button is held pressed at this point for more than 1 second an audio alarm will sound and the credit will be zeroed. Pressing the TEST button a second time will initiate the self test routine. The sequence of events should be as follows:

1. The reels will spin and stop on position one. This should correspond to the first symbol on each reel band being positioned on the payline. The three reel illumination lamps associated with each reel should light to indicate the interrupter flags are breaking the light to their corresponding photocells. Carefully moving the reels manually will indicate the margin in which these are operating.

This test can be repeated by pressing the TEST button.

To continue wait 20 seconds or press the START button.

2. Each lamp will be switched on and off in a logical sequence. During the lamp sequencing the alphanumeric display should step through its full character set. Pressing or releasing any switch should result in an audio bleep. Coins accepted by mechanisms should respond as switches. If the coin is feeding a payout device, five coins should be paid out for each ten accepted. This facility enables the coin overflow to be effectively tested by repeating the process several times if necessary.

Operating a coin level detector should result in a bleep, plus a pulse on its corresponding payout device. This is useful when more than one payout is in close proximity to confirm that the detectors are related to their correct tube. The payout device can be tested by holding the A Reel HOLD button depressed for a few seconds. This should cause a payout of 20 coins from one of the devices. Other payout devices can be tested by likewise depressing the remaining HOLD buttons.

3. If the TEST switch is depressed a second time or the refill key is turned the triac drives (payout devices, lockouts, and refill meter) will be pulsed once and in sequence. This also applies to the 12V meters, but in addition any problems in sensing the meters will be displayed on the alphanumeric display. During the above sequence all the lamps will be flashed to enable failures to be easily spotted and a test is run on the complex sound generator. This test can be repeated by again depressing the TEST switch.
4. To terminate the test and return to normal operation, close the DOOR switches.

1.6 DEMONSTRATION AND TESTING

A facility is provided to permit wins or features to be easily induced for demonstration or test purposes. On opening the machines main primary access door re-initialisation takes place and a "DOOR IS OPEN" message is shown on the alphanumeric display. Half of the machines lamps will light in order to provide some illumination for the service engineer to work within the machine. After two minutes the lamps will time out, go off and the other half of the lamps will come on to avoid overheating. This will repeat every two minutes while in this state. Pressing the internal TEST button once will proceed to the demonstration mode as follows: -

NOTE: Pressing the TEST button twice will cause entry into the self test mode (see section 1.5).

Establishing credit:	On opening the door and pressing the "TEST" button 20 credits are automatically established. These may be replenished by pressing the "DOOR" switch and then the "TEST" button again or by inserting coins. Pressing and holding the "TEST" button while opening the machines door will clear all the credit on the machine and proceed to the Out of Credit lamp display mode. Credit may also be cleared by pressing the "DOOR" switch and then holding the "TEST" button pressed for more than 1 second until an audio alarm is sounded when no credit will be established.
Induce Wins:	The reels may be stepped forward by holding the "SAVE IT" and the appropriate "HOLD" buttons depressed until the desired combination is on the payline. Hold is automatically applied and it is only necessary to press the "START" button to complete the operation. The reels may be stepped backwards by using the "NUDGE UP" and "HOLD" buttons.
Induce Hold and Feature Hold:	Hold can be induced by simultaneously pressing "NUDGE UP" and "SAVE IT" buttons.
Cancel Feature Hold:	Feature Hold can be cancelled by pressing the "AUTONUDGE" button.
Force Gamble Win:	Hold the "NUDGE UP" button depressed whilst pressing the "GAMBLE" button during any gamble feature.
Force Gamble Lose:	Whilst in a gamble operate the "REFILL" key before pressing the "GAMBLE" button.

1.7 DOOR SWITCHES

MPU4 machines will only function in a normal operational manner if all the machine doors are detected as closed. The condition of the doors is determined by at least one and sometimes two microswitches. The switches are wired to be open circuit when the door is closed. If more than one switch is fitted, they are wired in parallel.

A door being detected as open will have the following effects:

- i) The machine will re-initialise, spinning the reels and displaying its version number as on power up.
- ii) The alphanumeric display will show the message "*DOOR IS OPEN*" and will remain in this condition until either the doors are detected closed or the TEST button is pressed.
- iii) No transaction will be recorded on either the electro-mechanical or electronic metering systems.
- iv) The prior status of the machine in terms of credit, features etc., will be preserved and restored when the doors are closed.
- v) Credit will be made equal to 20 for testing or demonstration.
- vi) The electronic metering is made available through the KEY operated switch (REFILL switch).
- vii) Operation of the payout slides is prevented (except during slide test). An audio tone indicates when payout would normally take place.
- viii) Self test can be invoked by pressing the TEST button, a second time.
- ix) Provision is made available to set up wins or features for test and demonstration.
- x) In machines intended to be fitted with Data Capture, protocol does not require to be maintained. This enables the machine to be tested without a Data Capture unit fitted.

1.8 ELECTRO-MECHANICAL METERS

Electro-mechanical meters for recording the monetary transactions are fitted to most machines. They are normally mounted on a panel located behind the primary cash door at the front of the machine. In AWP machines the meters are identified as follows:

Meter No	Function	Unit of Measure
1	Cash In	10p
2	Cash Out	10p
3	Token In	10p
4	Token Out	10p

Also a Token Refill meter (5) is located remote from the other meters and in a position where it can be read from outside the machine. Coins paid for change, as in the case of the £1 are not recorded on the coin out meters, as the cash balance within the machine remains unchanged. Change for £ 1 is normally paid as 1 x 50p + credit which permits the 50ps in the cash box to be reconciled via the electronic metering as:

50p in -50p out -£ 1 in for change = 50ps in box.

In Club machines all the metering is in 10p units as follows:

Meter No	Function	Unit of Measure
1	Cash In	10p
2	Cash Out	10p
3	Refill (located remotely as 10p on AWP's)	

The meter information is stored and the meters are pulsed even while the machine is in use so that the game cycle is optimised.

1.9 ELECTRONIC METERS

Most MPU4 machines are fitted with an electronic metering system which can be displayed on the alphanumeric display.

The meters are accessed by turning the REFILL key with one of the machines doors open.

Pressing the START button will enable each meter to be displayed in sequence. The NUDGE UP button can be used to step the sequence backwards.

The meters are classified into three groups:

- i) Short Term Accountancy.
- ii) Long Term Accountancy.
- iii) Service History.

The Short Term Accountancy, which are the first to be displayed, record all transactions since previously being reset to zero. All monetary values are displayed as £'s in increments of 10p.

The Long Term Accountancy records the same or a subset of the information as above but cannot normally be reset to zero. Long Term meters are prefixed 'L'.

The Service History is a log of up to sixteen entries recording the reason for any alarm condition the machine has previously entered. (See section 2.10).

In addition to the START and NUDGE UP buttons other buttons can be used to select the required meter group.

Press HOLD A to jump to the start of Short Term Accountancy.

Press HOLD B to jump to the start of Long Term Accountancy.

Press HOLD C to jump to the start of Service History.

The Short Term Accountancy and Service History metering can be cleared, (whilst in metering mode), by stepping the meters to the appropriate group and then holding the CANCEL button depressed. The machine will give 5 beeps and then a continuous tone to indicate that group of meters has been cleared.

The Long Term meters can only be cleared by running a special program module in the MPU4. This is done before any machine or MPU4 spare unit leaves the factory.

The typical Short Term electronic meters in an AWP machine are as follows (in order of appearance):

VTP	Value of total play (multiply by 10 to find games played for a 10p stake machine).
PERCENTAGE	Percentage payout to one decimal place.
TARGET	Percentage payout to which the machine is currently set to operate.
10P IN	Value of 10p's in for games.
20P IN	Value of 20p's in for games.
50P IN	Value of 50p's in for games.
PND IN	Value of £1's in for games.
CASH IN	Total value of cash in for games.
10P OUT	Value of 10p's out for wins.
50P OUT	Value of 50p's out for wins.
PND OUT	Value of £ 1 's out for wins.

CASH OUT	Total value of cash out for wins.
TOKEN IN	Value of tokens in for games.
TOKEN OUT	Value of tokens out for wins.
TOKEN REF	Value of tokens refilled.
TOKEN BAL	Token balance = (TOKEN OUT- TOKEN IN -TOKEN REF)
PND CHNG	Value of £1's in for change.

The typical Short Term electronic meters in a Club machine are as follows (in order of appearance):

VTP	Value of total play (multiply by 10 to find games played for a 10p stake machine or 20 for a 5p stake machine).
PERCENTAGE TARGET	Percentage payout to one decimal place.
	Percentage payout to which the machine is currently set to operate.
CASH BAL	CASH IN + REFILL -CASH OUT
10P IN	Value of 10p's in for games.
20P IN	Value of 20p's in for games.
50P IN	Value of 50p's in for games.
PND IN	Value of £1 's in for games.
CASH IN	Total value of cash in for games.
1 OP OUT	Value of 10p's out for wins.
50P OUT	Value of 50p's out for wins.
PND OUT	Value of £1 's out for wins.
CASH OUT	Total value of cash out for wins.
10P REF	Value of 10p's in for refill.
50P REF	Value of 50p's in for refill.
PND REF	Value of £1's in for refill.
REFILL	Total value of cash refilled.
PND CHNG	Value of £1's in for change.

All monetary values are displayed in £'s. Coins paid out for change are not recorded.

1.10 OPTION SWITCHES

The MPU4 unit is equipped with two banks of eight dual in-line switches, identified as "Selector Switch 1 " and "Selector Switch 2". These switches can be used to select various options which enable the machine to be tailored to the requirements of an individual site. For an AWP machine the typical options offered on the Selector switches is as follows:

Selector Switch Bank No.1 (top bank)

Switch No.	Function when to the right (on)
Sw 1.1	£ 1 priority payout logic enable.
Sw 1.2	S10 single coin entry option.
Sw 1.3	Not used.
Sw 1.4	Not used.
Sw 1.5	Not used.
Sw 1.6	Not used.
Sw 1.7	Not used.
Sw 1.8	Not used.

Selector Switch Bank No.2 (bottom bank)

Switch No.	Function when to the right (on)
Sw 2.1	Change for £ 1 (5 credits + 50p change for £ 1)
Sw 2.2	Auto-hold enable.
Sw 2.3	Scottish coin handling enable (10p cash payout)
Sw 2.4	Out of credit display inhibit.
Sw 2.5	Normal spin option enable.
Sw 2.6	Coin alarm inhibit.
Sw 2.7	Low token level not to inhibit gambling to token values.
Sw 2.8	Single coin entry option.

For a Club machine the typical options offered on the Selector switches is as follows:

Selector Switch Bank No.2 (bottom bank)

Switch No.	Function when to the right (on).
Sw 2.1	Change for £ 1 (5 credits + 50p change for £ 1)
Sw 2.2	Auto-hold enable.
Sw 2.3	Stake select.
Sw 2.4	Out of credit display inhibit.
Sw 2.5	Normal spin option enable.
Sw 2.6	Coin alarm inhibit.
Sw 2.7	Gamble limit option.
Sw 2.8	Single coin entry option.

Selector Switch Bank No.1 (top bank) on a Club machine is used for adjusting the target payout percentage. With all the switches open (to the left) the target percentage is set at the minimum (72% for a Club machine). Each switch closed (to the right) will add 2% making the percentage adjustable from 72% to 88% in steps of 2%. The current setting can be verified by displaying the electronic meters and selecting TARGET (see section 1.9).

IF IN DOUBT the normal position for the option switches is as follows:

Selector Switch 1 -switches set alternately 1,3,5,7 to the left and 2,4,6,8 to the right.

Selector Switch 2 -all switches to the left (off). (For 10p stake machine).

For more details of these and any option switches refer to the game information sheet supplied with each machine.

1.11 VOLUME CONTROL

The volume level of the sound effects can be varied to suit the site by adjustment of a potentiometer identified as "Volume Control" on the MPU4 unit. It may be necessary to play several games in order to determine the optimum setting. The control cannot be turned lower than a minimum preset level.

1.12 REFILL

Most machines have the facility to top up the payout tubes externally. In A.W.P.'s this applies to tokens and in a Club machine to cash. This is achieved by turning the key operated switch on the front of the machine (with all doors closed) and feeding the required coins through the appropriate coin mechanism.

The coins will be recorded on the Refill meter in view through a window in the front glass.

On Club machines the total value of the refill will also be displayed on the alphanumeric display.

On A.W.P.'s an audio bleep is given for every token refilled and when the machine detects that the token tube is full the token lockout is closed to prevent further coin entries.

Most machines have a warning lamp to indicate when payout levels are low and refill is required. During refill some machines may indicate specifically which denominations are empty through the alphanumeric display.

1.13 FLOATING

When a machine is collected it is good practice to ensure that the payout tubes are full and can be achieved by feeding coins into the top of the tubes directly. This may require moving the machine to gain access through the rear door.

However, on machines fitted with a switch to detect the front cash door open, a facility is provided to permit the tubes to be floated without moving the equipment.

By operating the refill switch with the cash door open, coins can be fed to the tubes through the appropriate coin mechanism. No credit will be given or coins recorded. The tube will be full when the coins overflow to the cash box.

1.14 COIN LEVEL DETECTORS

Machines fitted with slide payout devices frequently have one or more coin level detectors fitted to their tubes. The operation of these devices is described in section 2.9. These detectors may be located at the bottom middle or top of the tube dependent on the application.

Those located at the bottom are sensing when the tubes are empty. This information could be used to switch payout to another device or cause a "Call Manager" condition.

Those located in the middle, are indicating when the level in the tubes is low rather than empty. This information is normally used to limit further emptying of this tube by paying some values in other denominations, inhibiting insertion of other coins or limiting gambles.

Those located at the top of the tube indicate that it is full. This is used to divert coins to some other destination. For example to a second payout tube or down to the cash box.

1.15 CALL MANAGER

Some machines, especially those intended for the Club market use the payout tube level detectors to determine when the machine is empty of cash. If this occurs whilst the machine is paying out, the operation is halted and a warning "Call Manager" message is flashed. This may consist of a lit panel or a caption on the alphanumeric display and an associated audio warning.

The machine may be refilled using the key operated switch in the normal way. The alphanumeric display will indicate which coins are delinquent. Payout will be resumed when the key is removed.

Alternatively the tubes may be filled directly by opening the machine. Again payout will be resumed on closing the door.

Should the Call Manager mode be entered with the machine doors detected open, then pressing the CANCEL button provides a convenient means of exit.

1.16 LINEWRITER

Most MPU4 machines have 128 bytes (or memory locations) of non-volatile memory which may be changed by the Customer to display messages of his choice during the out-of-credit display. The 128 bytes are arranged in 8 buffers (1,2,3,4,5,6,7,8) of 16 characters each and are displayed as two messages 1,2,3,4 and 5,6,7,8 during the out-of-credit display.

Before displaying any buffer the program checks that there are characters in it. If a buffer is found to contain nothing but spaces it will not be displayed. The normal sequence of events for the first message is as follows:

Buffer 1 is tested to see if it contains anything, if it does it is faded on and then off. Buffer 2 is tested to see if it contains anything, if it does it is faded on and then off. Buffer 3 is tested to see if it contains anything, if it does it is faded on and then off. Buffer 4 is tested to see if it contains anything, if it does it is faded on and then off.

From this it can be seen that if all four buffers in a message are clear no message will be displayed.

In order to allow the customer to change the contents of these buffers an Editor has been provided. To use the Editor the back door is opened, the REFILL key turned and the TEST button pressed. The display will show "BUFFER 1" and then display the contents of the buffer. This is the first of the eight buffers. To step to the next buffer press the COLLECT button and to step to the previous buffer press the GAMBLE button.

A full stop is used within the buffer as a cursor to show which character is being edited. This cursor may be moved to the next character by pressing the HOLD C button. On reaching the extreme right of the buffer it will wrap-around and re-appear at the left hand side. To enter or change a character in the buffer use HOLD C to step the cursor to the correct point, and press either HOLD A, which will cause the character at that point to step up through the alphabet, or HOLD B, which will cause it to step down.

The CANCEL button may be used at any time to clear the whole of the buffer being displayed.

PLEASE NOTE: full stops and commas are individual characters requiring one byte each in the buffer. Before attempting to enter a message into the buffers it is recommended that the text is worked out first on paper to see if it will fit into blocks of 16 characters, and how best to distribute it between the buffers.

Once a message has been entered and any unused buffers cleared the second message can be entered into buffers 5,6,7,8. When both messages have been entered turn the REFILL key back to its normal position. Invoke the out-of-credit display and the messages will be displayed.

On switch-on the program checks the contents of the buffers against a checksum byte and if they have become corrupted it clears them all out.

1.17 REEL SPIN

The speed of the reel spin can be selected Normal or Fast, by Option Switch 5 on Selector Switch 2.

(Left = Fast, Right = Normal). In the Fast position the spin is as fast as possible for the shortest game cycle. In the Normal position, the reels are rotated slower for a longer game cycle which can be more acceptable in some situations.

In sites where the supply voltage is below nominal (240v) then some problems with running of the fast speed may be experienced. If in doubt select normal spin.

WARNING

240 volts is present within the machine. Only suitably qualified personnel should carry out servicing. Disconnect mains lead before touching any internal components.

SERVICE INFORMATION

PART 2

2.1 MPU4 SYSTEM

The MPU4 System comprises a number of key components which in combination provide a flexible reliable and economical solution for today's fruit machine.

The Key components are as follows:

- i) MPU4 control unit.
- ii) MPU4 program module.
- iii) MPU4 reel assembly (3, 4 and 5 reels)
- iv) MPU4 transformer/power supply.

All machines using the MPU4 System use essentially the same four items listed above and are entirely interchangeable between machine types. The advantages to this approach are obvious and have been well demonstrated with our previous MPU Systems.

Key MPU4 components are not interchangeable with previous Barcrest MPU Systems.

2.2 INTERCONNECTIONS

2.2.1 GENERAL

Fig.1 shows how the various components are connected within a typical MPU4 machine.

The lamps are connected to the MPU4 via a distribution board which in turn is linked to the MPU4 via two jumpers.

All machines however still use a cable harness to connect the button lamps, switches, speaker and solenoids.

Some machines do not use a distribution board but rely on a main cable harness to connect all the lamps, switches etc.

Other items, reels, displays, meters, transformers, electronic coin mechs, and data capture are interfaced through individual jumpers and simple extension harnesses. Connections to the MPU4 are given in more detail in Fig.2

2.2.2 I.D.C. CONNECTORS

All connections from the unit, with the exception of the Dataport are through 156 type in-line connectors. The header (male pins) are positioned around the periphery of the printed circuit board to provide good mechanical support and minimise flexing. The 156 refers to the pitch of the pins, 0.156 inches or 3/16. Wires to the MPU4 are terminated in female housings using normally I.D.C. or alternatively, crimped connections. I.D.C. (or insulation displacement connection) is a relatively new method of termination which offers advantages of reliability and economy. The wire is forced into a 'U' groove in the terminal which displaces the insulation and makes contact with the conductor underneath. The colour of the nylon housing indicates for which gauge of wire the 'U' groove is designed. In the case of MPU4 most wires are 13/02 and therefore most of the I.D.C. housings are coloured red.

The in-line I.D.C. connectors are identified in three ways:

- 1. The number of ways - which varies from 4 to 24.
- 2. The colour of the cap - a colour coded cover is clipped into each housing which holds the wires into location.
- 3. The position of the key - has to match a missing male pin on the header.

Crimped in-line connectors are identified in a similar way, except the colour coding is applied to the body of the housing rather than the cap. Correct orientation of the connectors is clearly determined by physical constraints and key location. Pin number identification is moulded onto the side of the housing.

It should be noted that the jumper links in the case of a 5 way for example are connected:

	1	-	1		1	-	1
	2	-	2		2	-	2
Not	3	-	3	but	3	-	3
	Key -		key		key -		key
	5	-	5		5	-	5

Therefore the jumpers are handed and can only be physically connected in one direction.

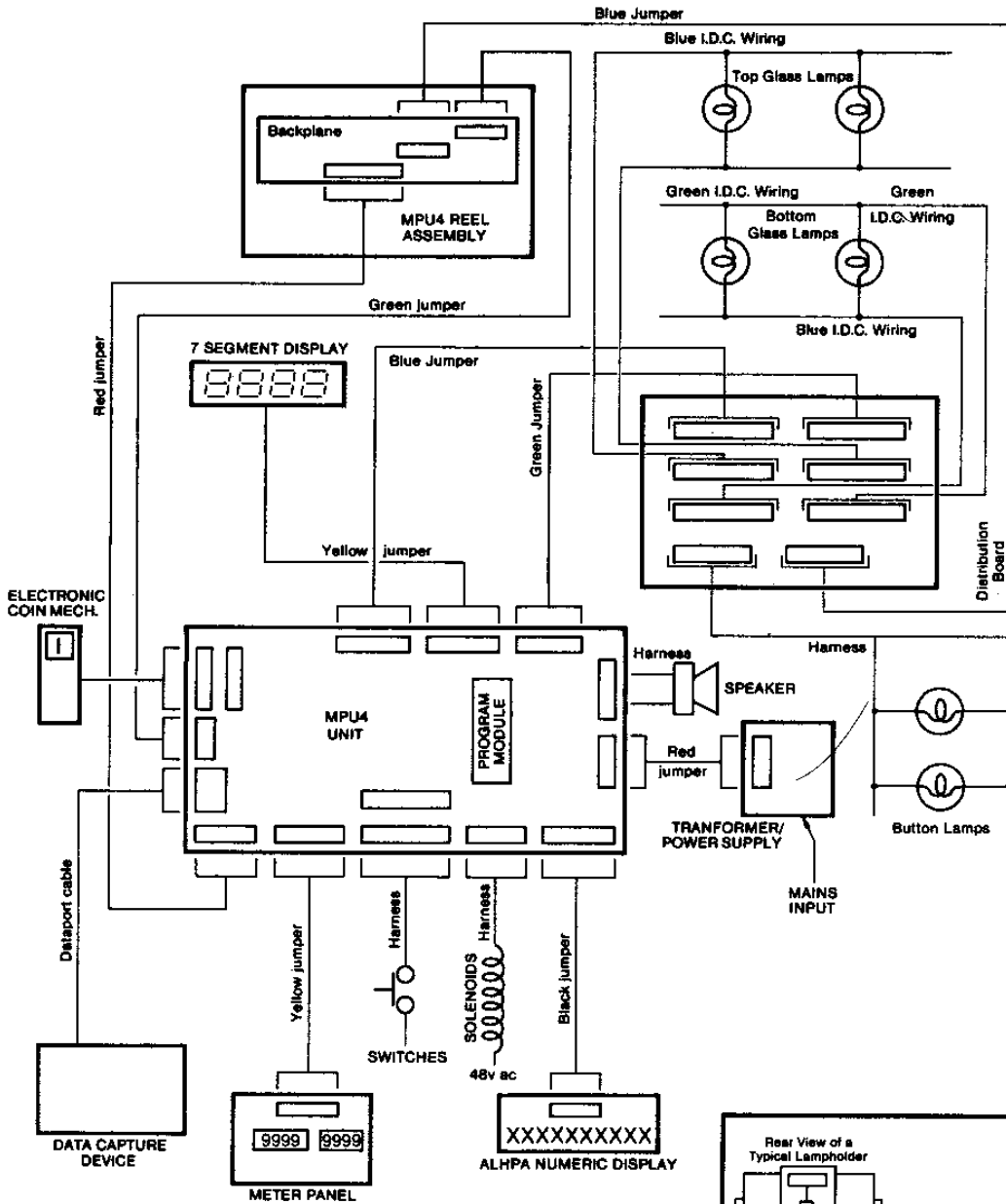
2.2.3 MAIN HARNESS DISTRIBUTION BOARD

The main harness distribution board is shown in Fig. 1.1. It consists of eight male I.D.C. headers that are used to connect the machine's lamps to the MPU4. The distribution board is connected to the MPU4 by two jumpers.

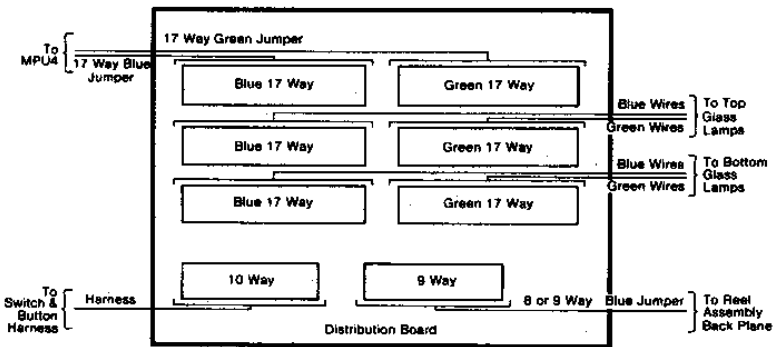
The 17 way blue jumper carries the lamp selects and the 17 way green jumper carries the lamp drives.

Connections for the top and bottom glass lamps in the machine are made via the three pairs of 17 headers at the top of the board. The 17 blue and 17 way green connectors for the lamps are connected to the jumpers from the MPU4 in a 1 to 1 link. The lamp selects and drives needed for the reel back lights are brought out via a 9 way header at the bottom of the board. This is connected to the backplane board on the reel assembly via a blue jumper.

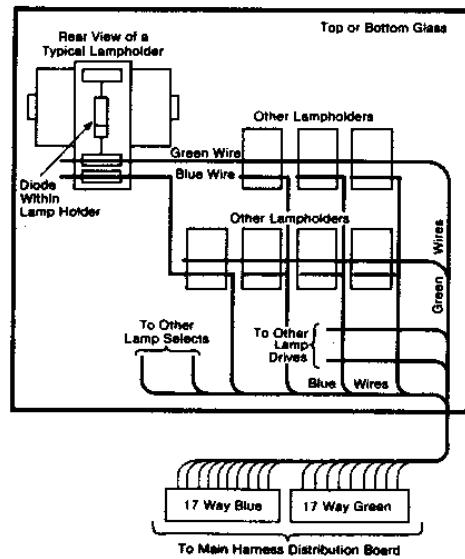
This jumper uses only eight of the nine ways on 3 and 4 reel machines and all nine on 5 reel machines.



**FIGURE 1
MPU4 SYSTEM INTERCONNECTIONS**

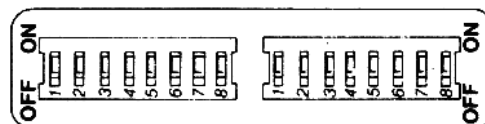


**FIGURE 1.1
MAIN HARNESS DISTRIBUTION BOARD**



**Figure 1.2
I.D.C. LAMP CONNECTIONS**

FIGURE 2
MPU 4 PLUG LAYOUT



SELECTOR SW 1

SELECTOR SW 2



FIGURE 3
MPU 4 REEL ASSEMBLY
and typical adjustable base.



FIGURE 4:
CONNECTIONS TO REEL BACKPLANE



FIGURE 4.1
CONNECTIONS TO 5 REEL BACK PLANE

ROTATION		STATOR 1		STATOR 2	
		Switched wires		Switched wires	
CLOCKWISE	ANTICLOCKWISE	ORANGE	YELLOW	BROWN	BLACK
↓	↑	On	Off	On	Off
		On	Off	Off	On
		Off	On	Off	On
		On	On	Off	
		On	Off	On	Off

Motor phase with first symbol on payline

FIGURE 5
STEPPER MOTOR SWITCHING SEQUENCE

The connections for the lamps used in the front panel buttons and switches are brought out on the 10 way header at the bottom of the board. This connects into the harness for the machine to take the necessary lamp selects and drives to the button lamps.

2.2.4 I.D.C. LAMP CONNECTIONS

Two colours are now used and are connected directly from lamp to lamp.

Each lamp is connected between a green lamp drives line and a blue lamp selects line. The wire (Green or Blue) is inserted to catch under the barbs of the moulding on the lamp holder. It is then pressed down into the metal contact which cuts through the insulation and makes contact with the conductor. Should the wire become loose, move it sideways before pressing it down into the contact so that connection is made in a new position (see Fig. 1.2).

Blue is used for lamp select lines and green for the lamp drives. The blue and green wires from the groups of lamps on the top or bottom glass are formed into two bundles which go into two female 17 way I.D.C. plugs, one green and one blue, which in turn connect into the distribution board. Up to 16 separate blue wires are used on the 17 way Blue connector and up to 16 on the 17 way Green connector (see 2.5.3).

The green wire should be connected to the contact nearest the centre of the lampholder and the blue connected to the outside contact. This is then connected to a diode inside the lampholder and thence to the other side of the bulb.

2.2.5 REPLACING GLASS ON MACHINES FITTED WITH I.D.C. LAMP HOLDERS

Before attempting to remove glass from the machine ensure that you are familiar with the lamp test sequence. If unsure then enter the lamp test routine (section 1.5). Take this opportunity to replace any defective lamps.

Ensure the machine is powered off. Trace the wiring from the glass to be replaced and disconnect the appropriate Green and Blue connectors from the lamp distribution P.C.B.

Unscrew the frame containing the glass from the cabinet and remove from the machine. Remove the screws securing the clamping plates and remove the glass from the frame. Lay the above glass, lampbox and harness assembly face down on a flat surface and next to the new glass and lightbox assembly. Use clips to consolidate the wiring on the back of the most congested points. Unclip all the lamp holders but take care to ensure that the holder remains in position with the lamps still located by the holes in the lampbox. Use a piece of stiff card in the following manner. Place the card at the widest edge of the glass and lift the first lamp holders onto the card. Carefully shuffle the card over the top of the lampbox, transferring the lamp holders and maintaining the form of the cable harness. Lift the card, lamp holders and harness and place on top of the new lampbox and glass. Carefully slide the card away allowing the lamp holders to drop into appropriate location onto the new lampbox. Clip holders to drop into appropriate location onto the new lampbox. Clip the lamp holders into the appropriate positions. Fit the glass into the frame and frame into cabinet. Remake electrical connections. Power on and use the lamp test routine to ensure the lamp positions are correct.

2.3 REEL ASSEMBLY

2.3.1 GENERAL

The MPU4 reel assembly is constructed almost entirely of injection moulded plastic components (Fig.3). A modular construction is used and consists in the main of a side frame carrying a stepper motor and reel drum. Captive spacers provide a means of locating the side frames with reference to each other and three threaded tie rods passing through the spacers clamp the whole into a rigid structure. All electrical connections are connected to a printed circuit backplane and provide an interface with the MPU4 (Fig.4).

There are currently five types of reel assemblies for use in MPU4 based machines. These are 3, 4 and 5 reel with normal width bands and 3 and 4 reel with wide bands. To replace the reel assembly in any machine it is necessary to remove the bands from the defective unit and refit to the replacement unit.

2.3.2 THE MOTOR

Each reel is driven by a 48 step stepper motor of a type identical to those used on the MPU3 reel assembly.

The stepper motor consists of two stators each with twelve pole pairs and each with a toroidal winding to two coils and a rotor which is common to both. The rotor consists of two permanent magnets fixed to a common spindle, each magnet having poles to match its stator. The second stator is rotationally offset from the first by half a pole spacing (i.e. 7.5 degrees). Thus by directionally energising both stators the motor has 48 stable positions.

Directional energising in this application is achieved by applying 12v D.C. drive through switching transistors, to either the first or second winding on each stator. By changing the sequence of the drive as shown in Fig.5 the rotation of the rotor and its direction can be controlled in steps of 48 per revolution.

When stopped one coil in each stator will be energised. In order to reduce the power dissipation in the motor the MPU4 continuously switches the drive to these two coils on and off at a frequency of 250Hz. For this reason the voltage across an energised coil at standstill should read about 7 volts. Each motor is electrically connected to the backplane via a 7 way connector (Fig.4).

Four diodes mounted on the backplane in parallel with each winding provide a path to maintain the inductive current as each stator is switched off. Connectors for all 3, 4 or 5 motors are brought to a red 16 way connector for direct linking to a similar connector on the MPU4 via a 19 way red jumper. In addition on 5 reel assemblies the connections for the fifth reels motor drives are brought to a blue 10 way connector which links directly to the E/M Meters port on the MPU4 via a 10 way blue jumper (Fig.4.1). The reel side frame is sandwiched between the motor mounting flange and a clamping plate. Four screws pass through holes in the flange, adjusting slots in the frame to captive threaded inserts in the plate. These screws are tightened to a critical preset torque sufficient to provide adequate clamping without imposing creep problems in the plastic side frame.

2.3.3 THE REEL DRUM

Each reel drum consists of a three part injection moulding comprising a drum and rim moulded in white translucent plastic and an interrupter flag moulded in black opaque material.

The drum is sandwiched to a diecast hub by a clamping plate and three self-tapping screws. The hub is securely attached to the motor shaft by a roll pin passing through cross holes common to the shaft and hub.

The hole in the motor shaft is not referenced to any specific rotor-index position. It is therefore necessary to provide a means of aligning the reel index positions to the reel side frame. This is achieved by slots in the side frame which allow the motor body to be rotated a few degrees about its axis before being clamped into position by its four fixing screws.

This alignment takes place in production and once set should never normally require to be adjusted, unless the motor is removed from its frame for any reason. However it can easily be checked in the field as shown below.

2.3.4 MOTOR ALIGNMENT

Motor to frame alignment can be checked as follows. Put the machine into self test by pressing the Test button. (See section 1.5) The reels will revolve and come to rest with the first reel band symbol positioned on the payline. A pointer moulded into and positioned near the top of the side frame should exactly line up with the line moulded onto the side of the corresponding reel drum. (Rather similar to the T.D.C. marking on the crankshaft pulley of a motor engine). Any misalignment can be corrected by slackening the motor mounting screws and turning the motor until lined up correctly. Care must be exercised on retightening, these screws are not to be overtightened (see section 2.3.2)

2.3.5 PHOTO ELECTRICS

The MPU4 can instruct the drive transistors to cause either forward or reverse drive in discrete steps, but will not know the true position until it receives some tell-back from the reel. This takes the form of a marker pulse occurring once per revolution and corresponding to the first symbol on the reel band aligning with the payline. This is achieved by a flag attached to the reel drum interrupting a beam of light from a LED (Light Emitting Diode) source to a photocell.

When the machine is first switched on the reels spin at least one revolution for the MPU4 to determine the exact reel position. If the photo circuit is not interrupted during this initialisation an alarm condition is entered with the identity of the offending reel indicated on the alphanumeric display. The photo components are mounted on a small printed circuit board and fixed by two self tapping screws to the reel side frame. A flying lead terminated in a 5 way connector interfaces each photoboard to the backplane.

A quad comparator on the backplane compares the signal received from the photocells with a reference signal and determines whether each photocell is illuminated or not (Fig.22). The LED's are sourced across the 12v supply through a series resistor mounted on the photoboards and driven from a transistor switch in the MPU4. Photo connections from the backplane to the MPU4 are made by a green 9 way connector and jumper. On 5 reel assemblies the signals from the Photocells are multiplexed onto the 9 way connector under the control of the MPU4 (see Fig.22.1)

The light from the LED's is infrared and not visible to the human eye. When the Self Test mode is entered, the reels spin and index to the start of the reel band and the obstruction of the photo electrics by the flag is indicated by back illumination of the first symbol. Correct functioning can be verified by manually adjusting the reel position and observing the points of operation.



FIGURE 6
MPU 4 REEL ASSEMBLY



FIGURE 7
MPU TRANSFORMER/POWER SUPPLY



FIGURE 8
POWER SUPPLY CIRCUIT DIAGRAM



FIGURE 9
MPU TRANSFORMER/POWER SUPPLY
Wiring and inter connections

2.3.6 SYMBOL ILLUMINATION

The MPU4 reel assembly has the ability to back-illuminate the symbols independently on, above, and below the payline. This is achieved by three lamps within a lamp box and mounted within the translucent reel drum (Fig.6). The lamp box is clamped to the side frame by a single screw and may be adjusted through an arc to permit exact alignment with the reel band. The lamps are connected through a 7 way connector to the backplane which provides the necessary series diode for each lamp and combines the lamp connections for all to a common 8 way connector on 3 and 4 reel machines and a 9 way connector on 5 reel machines. This is connected to the main harness distribution board via an 8 or 9 way blue jumper.

A defective lamp can be easily be replaced as follows:

1. Remove reel assembly from machine.
2. Unclip backplane PCB from side frames (it is not necessary to remove any connectors).
3. Unscrew and remove the three tie rods.
4. Part the side frames either side of the offending reel to give access to the lamps.
5. Remove and replace the defective bulb (12v wedge base, 10mm).
6. Repeat the above in reverse order.

2.3.7 REEL BANDS

The reel bands for the MPU4 may have 24, 16 or 12 symbols and may be of the wide or narrow type. The required number of "stops" is determined by the MPU4 program and makes no difference to the rest of the reel assembly. Some bands are of the wider type and can only be fitted on reel assemblies that have the larger spacers fitted or reel assemblies manufactured to take the wider reels.

The bands are designed to be easily removed and refitted without re-alignment being necessary.

Each band is securely located beneath the rim on each side of the drum. Two notches near the start and finish of the band mate with a drive peg to ensure correct alignment and prevent any slipping. On some early versions of the wider reel assemblies the band is located under only one rim of the drum and secured to it by double sided sticky tape. The transparent leader at the start of each band is printed with machine identification and part number.

2.3.8 REEL ASSEMBLY FIXING

A reel mounting frame is screwed into the machine cabinet and provides a secure and accurate location in which the reel assembly resides. The base of the reel side frames is designed to mate with two latched location bars on the side frame. A third spring-loaded, sliding latch bar ensures the reel is securely locked into correct location on the mounting frame (Fig 3). To remove the reel assembly from the machine:

1. Open the cabinet rear door and release front glass frame.
2. Disconnect mains supply.
3. Disconnect the 19 way, 9 way and 8 way plugs from the backplane, connecting the reel to the rest of the machine.
4. Press the latch bar positioned at the side of the reel mounting frame.
5. Slide the reel assembly towards the back of the machine about 25mm, then finally lift the assembly through the front of the open cabinet.

To replace the reel assembly repeat the above in reverse order.

2.3.9 REEL ALARMS

The MPU4 is normally programmed to monitor correct operations of the reel assembly and give a warning alarm if a fault condition is detected. The alarm takes the form of an alternating audio tone, flashing symbol illumination on the culprit reel and an appropriate alphanumeric caption.

"SET UP ALARM" Occurs after the first initialising spin of the reels and indicates that the photo electric system has not detected the interrupter flag on one or more reels. Enter self Test mode to verify problem (section 1.5).

"SPIN ALARM" Occurs during a reel spin if an interrupter flag is seen other than 48 motor steps from when it was previously detected. Indicates that reel has been prevented from rotating freely for some reason.

A useful facility is provided, in that with the machine doors sensed open the self test routine can be entered from the alarm mode by pressing the TEST button as normal. (Section 1.5).

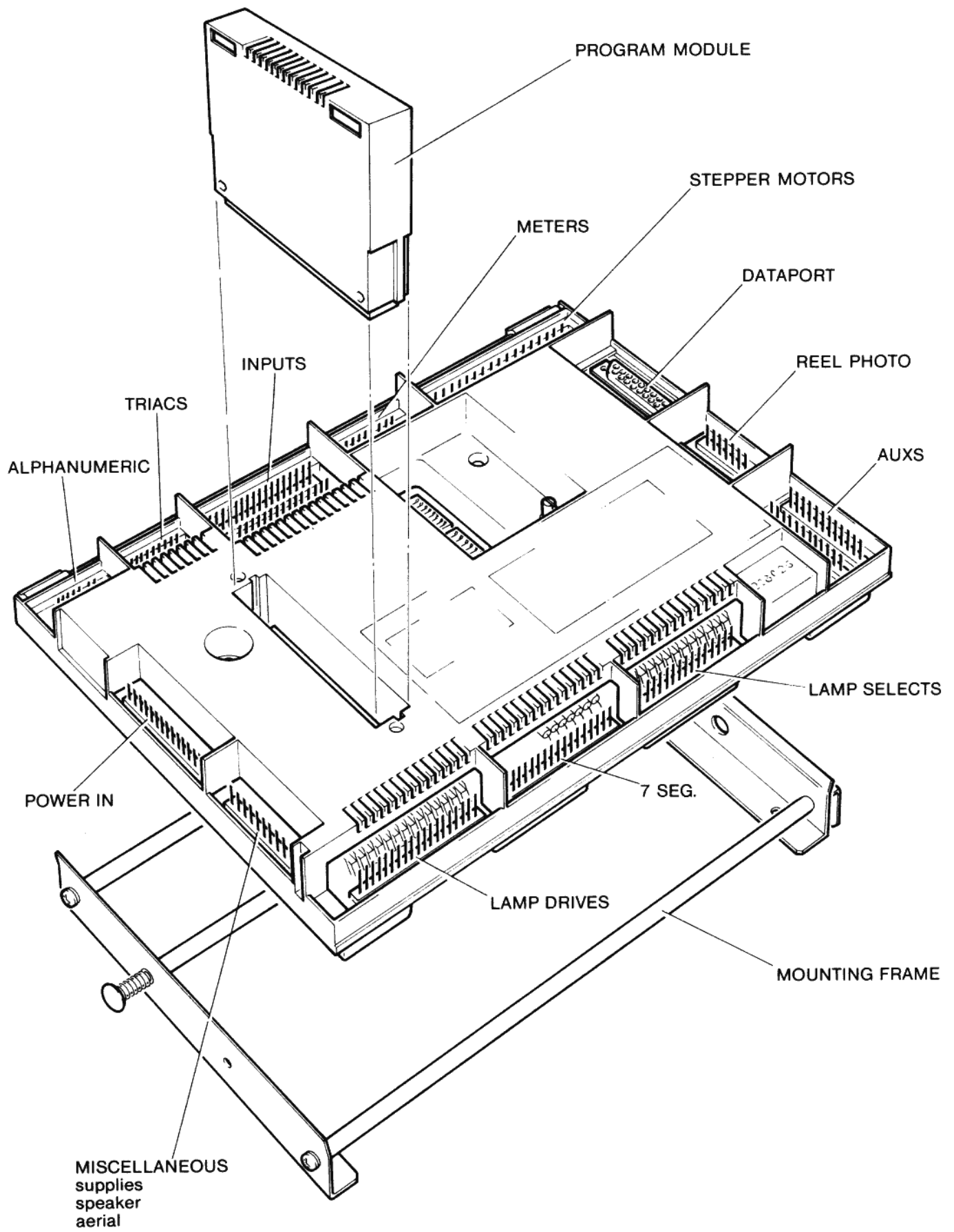


FIGURE 10
MPU 4

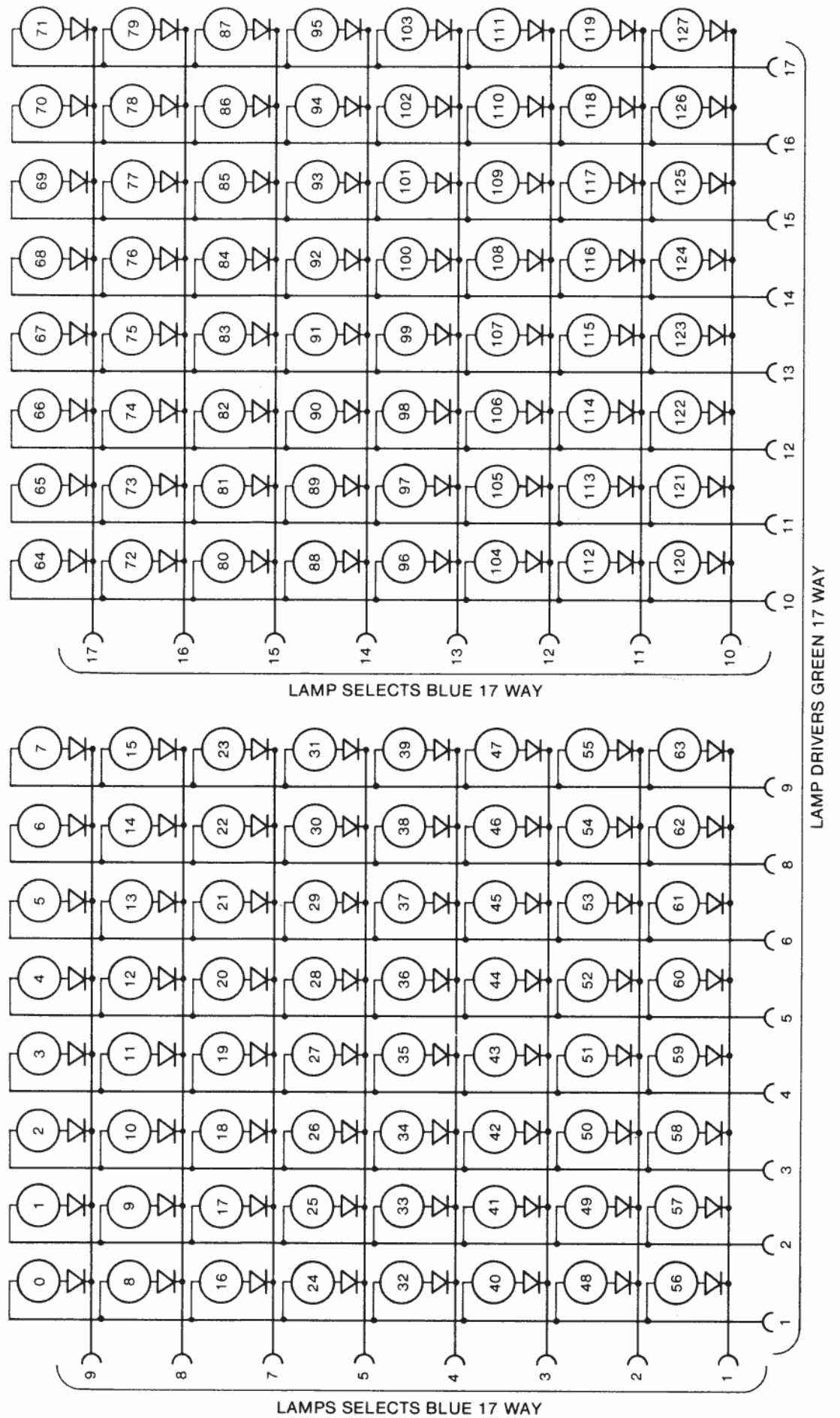


FIGURE 11
LAMP DISPLAY CIRCUIT



FIGURE 12
LAMP DRIVE AND SELECT CIRCUIT



FIGURE 13
MULTIPLEXER LAMP SELECT TIMING

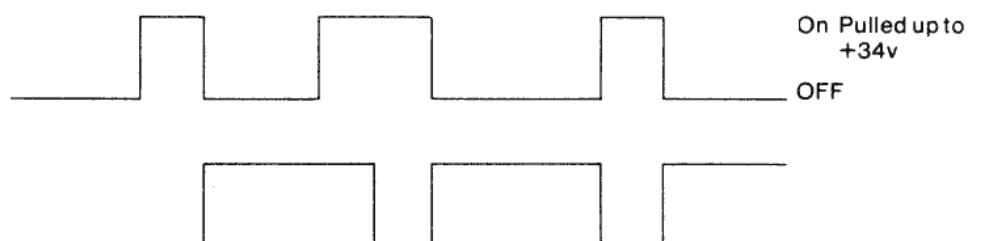
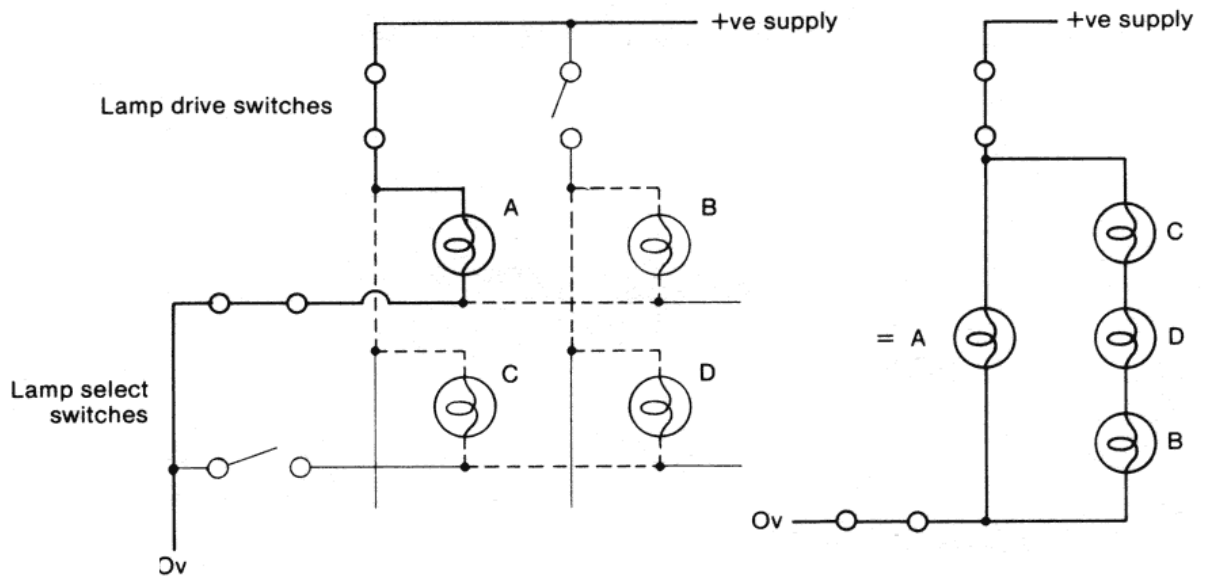


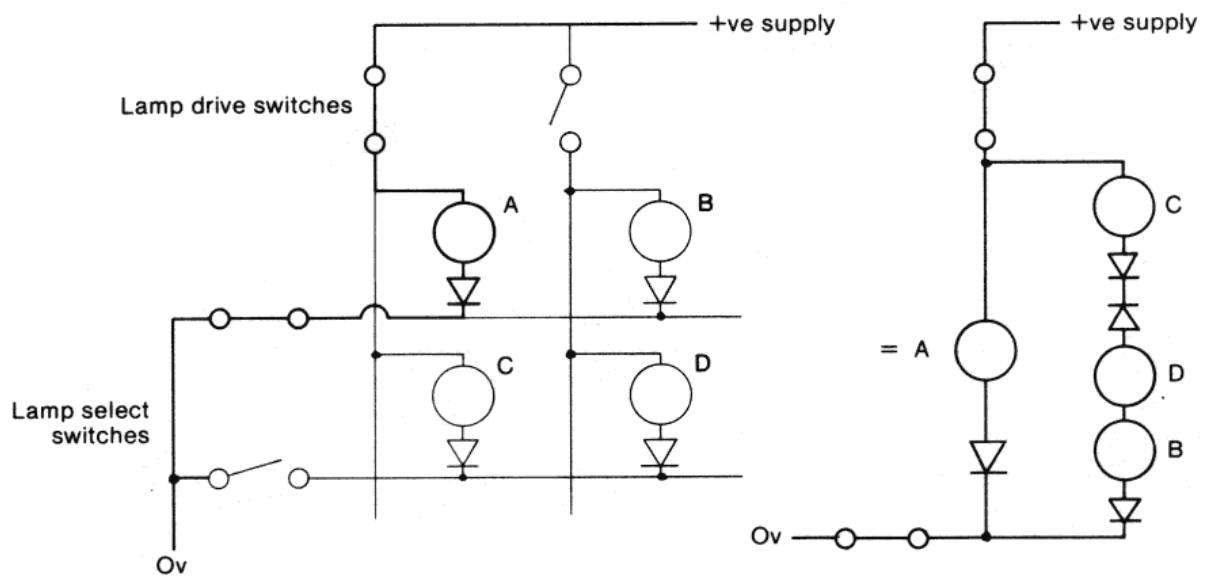
FIGURE 14
MULTIPLEXER LAMP - DRIVE TIMING Typical for two lamp drive lines.

Lamp multiplexer without series diode



Only lamp A requires to be lit but lamps B, C and D will also light dimly due to the series circuit in parallel with A.

Lamp multiplexer with series diode



Lamp A will light as above but the diode in series with lamp D is reverse biased and prevents current flow through the series circuit. Hence lamps B, C and D remain unlit.

FIGURE 15

WARNING

240 volts is present within the machine. Only suitably qualified personnel should carry out servicing.
Disconnect mains lead before touching any internal components.

2.4 TRANSFORMER AND POWER SUPPLY

Transformer and power supply is combined into one compact unit. (Figs 7 & 9) Connection to the mains is through I.E.C. Europlug which also provides a convenient means of isolating the MPU4 from any other mains driven circuits. Output connections are through a 15 way MTA connector and jumper to a similar connector on the MPU4 labelled "Power In". Fig 8 gives the circuit diagram.

The supplies provided by this unit are as follows:

SUPPLY	FUSE	USE
i) +12vDC	7.5A 1.1/4 inch	Input to regulator for +5v supply, for reel stepper motors, and Dataport.
ii) +34vDC	7.5A 1.1/4 inch	Multiplexed lamp supply.
iii) 48vDC	5A 1.1/4 inch	Solenoids.
iv) -12vDC	250mA20mm	Dataport.

All four supplies are electrically isolated until they reach the MPU4 where they are all commoned to a single zero-volt point. Most of the components are mounted on a printed circuit board designed for easy replacement or repair in the field without any unsoldering being necessary. The transformer can be tapped to 220v input by exchanging the white wire connected to the Eurosocket neutral and the orange wire connected to the dummy faston terminal mounted on the metalwork of the unit. (Fig 9). The transformer frame together with all items of external metalwork are connected to mains earth. All power supplies used in the MPU4 system are isolated from mains earth.

2.5 MPU4

2.5.1 GENERAL

The MPU4 comprises a microprocessor control system mounted on a single printed circuit board and housed in a specially designed injection moulded enclosure. (Fig 10). The size of the unit is the same as the MPU3, about that of a large book. However, the capability in terms of facilities, speed, and output capacity is twice that of the previous unit.

To interface to the outside world in-line connectors are terminated directly to the PCB and mounted around the periphery of the unit. This ensures good mechanical support when plugging or unplugging the connectors, minimising flexing of the PCB. The program module plugs into a receptacle moulded into the MPU4 top cover and mates with a 64 pin DIN connector mounted on the PCB. Once in position the module is held in location by an integral latch within the mouldings. Sixteen option switches are made available through an aperture in the cover, as are adjustments for audio volume and reset sensitivity. A LED lights to indicate presence of the +5v supply.

Part of the back of the MPU4 enclosure is formed by an aluminium heatsink for the +5v regulator.

This is at 0v potential and provides a screening plane for the PCB and an excellent point to connect the common terminal of a voltmeter for fault finding.

2.5.2 MPU4 FIXING

The MPU4 is secured into the machine cabinet by a mounting frame. (Fig 10). The unit can be released by depressing the spring loaded latch bar at the side of the frame whilst gently pulling the unit away from the frame. It is normally easiest to remove the MPU4 from the fixing frame before disconnecting all the connectors and removing the unit from the machine. **ENSURE THAT POWER IS OFF BEFORE DISCONNECTING ANY CONNECTORS.**

To install an MPU4 into the machine repeat the above in reverse order.

2.5.3 LAMP DRIVES

The MPU4 has the ability of directly controlling 128 individual 12v lamps. To provide this capability in an efficient, reliable and economic manner a time multiplexing technique is used (as in the MPU3). The multiplexer comprises two identical 8 x 8 matrices as shown in Fig.11. The total of sixteen rows of select lines are connected to the MPU4 through a 17 way Blue connector (16 + keyway). Likewise the sixteen columns of Drive lines are connected through a 17 way green connector. All lamps are 12V 10mm wedge base. On older MPU4 machines 2.2W bulbs were used but they have now been replaced by 12V 1.2W 10 mm wedge based bulbs. These give only slightly inferior illumination but have much lower power consumption allowing them to be left on for longer without damage occurring to the machines glass or reel bands. Fig.12 shows how the select and drive circuits within the MPU4 are connected to the lamps and power supplies. The lamp select transistors in each of the matrices are switched on for a 2ms period in sequence every 16ms (Fig.13). This forces the appropriate line and corresponding lamps connections to zero volts.

The sixteen lamp drive transistors are able to switch any of the sixteen lamp columns to +34Vdc (Fig.14). Thus by synchronising the drive and select lines it is possible to switch any combination of the 128 lamps across 34 volts for 2mS every 16mS. Lamps illuminated in this way will have a brightness equivalent to supplying them directly with 12Vdc (12V rms). However if the voltage across such a lamp is measured with a normal voltmeter (reading average voltage) only about 4 volts will be read. The diode connected in series with each lamp is to prevent a condition commonly referred to as back feeding. Because both sides of the lamps are switched, a secondary series path for the current is created which would result in three of the lamps, which should be off, glowing dimly for each lamp switched on. The reason for this and how the series diode solves the problem is illustrated in Fig.15. The I.D.C. and clip on lamp holders have the diodes combined and connected to a dummy terminal. Lamps within the push buttons use an in-line diode with spade connectors and the lamps on the reel assembly have the diodes mounted on the backplane. Each of the lamp drive transistors has its own current sensing circuit. This circuit is able to sense an over current situation to protect against short circuits.

2.5.4 SWITCH INPUTS

The MPU4 has the ability to accept 32 input signals from microswitches or similar devices. The switches are connected to the MPU4 through two 19 way connectors coloured orange and black Each connector carries two banks of eight inputs and two enable signals. Fig 16 shows how the switches are connected to the MPU4 through the inputs and enable signals. Switches are connected to be normally open contacts. The enable signals are normally of +5v but pull down to 0v for 2mS periods whilst the inputs are read. (See Fig 17). The enabling and sampling period is every 8mS for the orange connector and every 16mS for the black connector. These input enable signals are synchronised to the lamp multiplexer. When required to interface to inputs other than a mechanical switch circuit, for example a photo electric coin level switch or payout detector, a circuit arrangement similar to Fig 18 is employed.

2.5.5 TRIAC DRIVES

A means of driving ac loads such as solenoids or motors is provided by eight triac circuits. Normally the loads are fed from the 48vAC supply and connected to the MPU4 through a white 12 way connector as shown in Fig 19 .Switching is in the "neutral" with one side of the load connected to 48v with the return being made by the triacs to 0v.

2.5.6 METER DRIVES

The MPU4 provides the capability of directly driving up to eight 12v DC electro-mechanical counters. Connection is made to the meters through a 10 way yellow connector. Special circuitry within the MPU4 has the ability to sense whether meters are correctly connected. This facility may be programmed to give an alarm condition and prevent operation of the machine if for example the meter connector is disconnected. See Fig 26.

2.5.7 SEVEN SEGMENT DISPLAY DRIVES

Up to eight 7-segment displays can be directly connected to the MPU4 through the yellow 17 way connector shown in fig 20. The drive to the displays is multiplexed in a similar way to the lamp drives. The like segments of the common anode displays are connected in parallel and switched to the +5v supply by eight p.n.p. transistors. Eight enable lines switch each display to zero volts in sequence for a 2mS period every 16mS.

2.5.8 STEPPER MOTOR DRIVES

The stepper motors in the reel assembly are driven from transistor switches in the MPU4 (Fig 21). Each motor is provided with four transistors, able to switch the windings of each phase across the +12v supply. Red 19 way connectors on both the reel backplane and the MPU4 interconnect the two units through a simple jumper harness. When any stepper motor is stationary, the drive to the two phases required to maintain its position is modulated at a 50% duty cycle to conserve power and reduce dissipation.

2.5.9 REEL PHOTO INPUTS

The reel photo electric circuits are connected from the reel backplane to the MPU4 through green 9 way connectors and a simple jumper harness (Fig 22). Inputs from the four photo interrupters to the MPU4 are at TTL levels. A series resistor and zener diode protect against any over voltage or noise condition that could occur. A single transistor provides a means of switching the +12v supply to the LED circuits which are connected in parallel. The +5v supply to the reel backplane is buffered through a low value resistor.



FIGURE 16
SWITCH INPUTS CIRCUITS



FIGURE 17
INPUT ENABLE SIGNALS

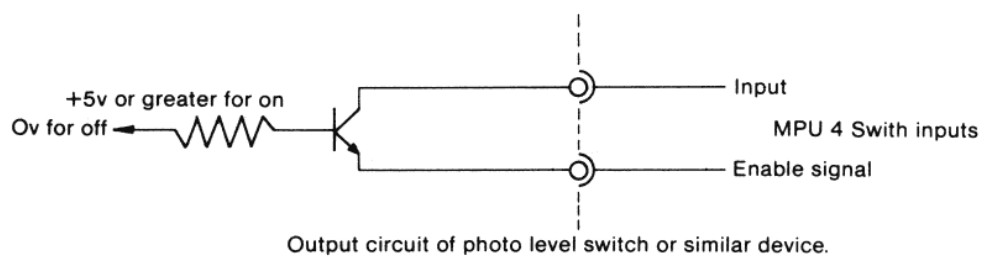


FIGURE 18



FIGURE 19
TRIAC CIRCUITS



FIGURE 20
SEVEN SEGMENT INDICATOR CIRCUIT



FIGURE 21
STEPPER MOTOR DRIVE CIRCUIT
 (Shown for reel D)



FIGURE 22
REEL PHOTO CIRCUIT
 (Shown for reel D)

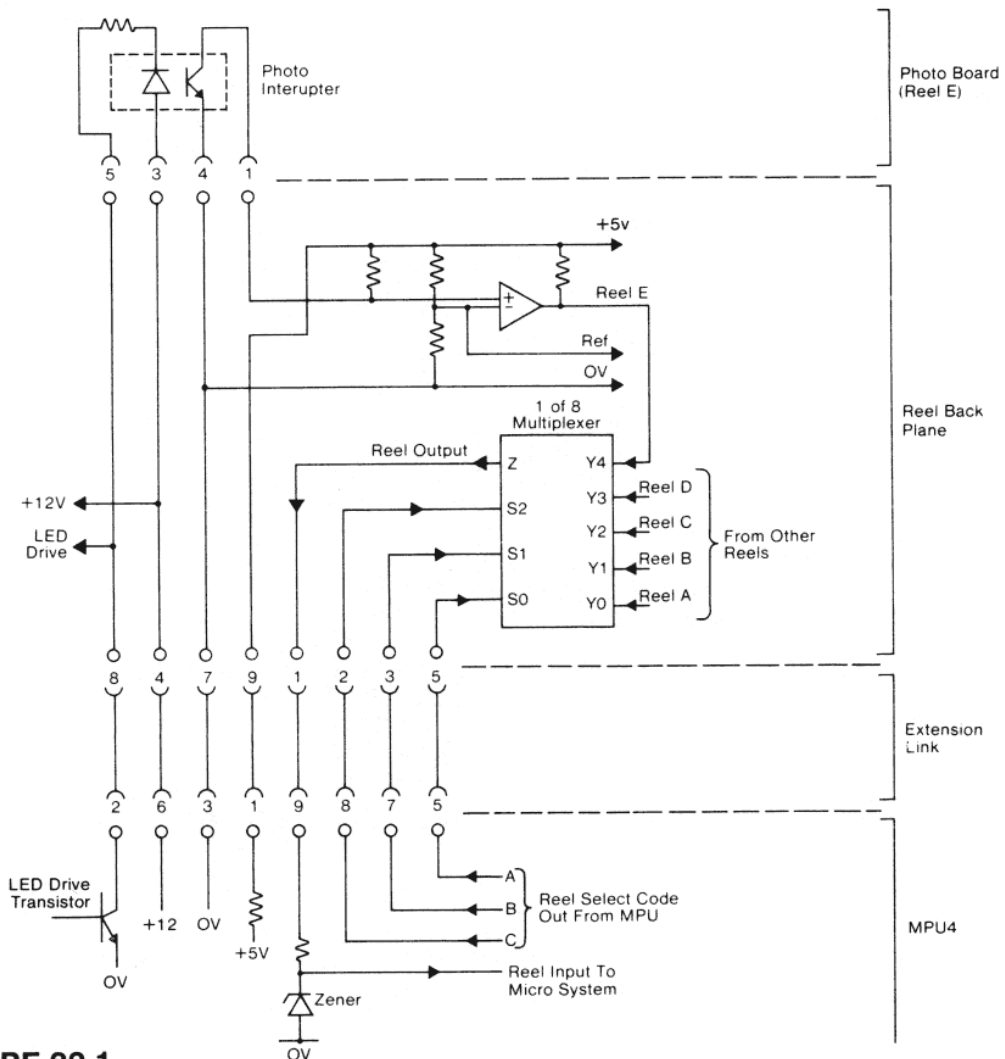


FIGURE 22.1
REEL PHOTO CIRCUIT FOR 5 REEL BACK BOARD (REEL E SHOWN)

2.5.10 ALPHA DISPLAY OUTPUT

Provision to drive the Barcrest Alphanumeric Display is made through a black 7 way connector on the MPU4. A Simple jumper harness links through to a similar connector on the display PCB.

The interface signals and connections are shown in Fig 23. Data is fed to the display serially in synchronism with a clock signal. A reset signal is used to initialise the display. All signals are at TTL levels.

Before initialisation takes place, it is quite normal to have random characters shown on the display, typically this might comprise all "C"s.

2.5.11 AUX PORTS

To enable a variety of peripheral devices to be easily interfaced and provide for future expansion of facilities two uncommitted eight-bit parallel ports are provided. The ports are both terminated in 12 way connectors coloured white and black for AUX 1 and 2 respectively. In addition the connectors carry 0v +12v supplies to power external electronic circuits as required. The sixteen data lines are TTL compatible and may be programmed by the MPU4 to act as inputs or outputs. Circuit protection is provided by low value series resistors and zener diodes.

2.5.12 MISCELLANEOUS CONNECTIONS

The blue 11 way connector makes available a number of supplies to power external circuits together with loudspeaker drive and aerial for the reset circuit.

2.5.13 DATAPORT

To enable MPU4 to be easily and securely interfaced to Data Capture systems, an industry standard Dataport is fitted. This consists of a 25 way D type socket with serial transmit and received signals with +12v and -12v power supplies as shown in Fig 24. The Dataport is also compatible with the RS232 standard used as a serial interface throughout the computer and telecommunications industry.

This provides an easy means of connecting devices like printers, terminals and modems.

2.5.14 POWER IN

All power to the MPU4 is supplied from the Transformer/Power Supply through red 15 way connectors on both units and a jumper harness as shown in Fig 25. The four supplies 48v ac, +12v, -12v, +34v are all isolated from each other at the transformer, but once within the MPU are commoned to a single zero-volt point.

The +12v is fed to an internal voltage regulator mounted on the aluminium heatsink forming the back to the MPU4 box, and provides the +5v supply necessary for all the logic circuits, An LED connected in parallel with this supply and visible on the front of the MPU4 gives positive indication of the +5v being present and correct.

Two separate zero volt connections are used in the MPU4 system. Signal zero (0v) is the return for the logic and low power signals. Power zero (0"v) is the return for all power and high current circuits.

These two returns are kept entirely separate within system and only connect at the zero volt point within the MPU4.

2.5.15 RESET CIRCUIT

The reset circuit within the MPU4 ensures that all the logic circuits initialise to an acceptable and known condition. The reset state is entered under the following conditions:

- i) For a half second period after power is first applied.
- ii) If the program module is unplugged.
- iii) If the mains supply drops below a minimum voltage, insufficient to ensure correct operation of the equipment.
- iv) For a half second period after the aerial reset has been triggered.

When reset is applied all output circuits are disabled and the only indication that power is applied is the LED Power indicator on the MPU4.

Immediately after the reset period the microprocessor will initialise the system which normally includes spinning all the reels through one revolution to determine their current position.

The aerial reset consists of a sensitive trigger circuit connected to an aerial wire embedded in the cable harness. Its purpose is to detect any gross electrical interference and reset the MPU at some point before the interference can influence the logic circuits. A sensitivity control identified as "Reset Sensitivity" is provided on the MPU4 front cover. This control is preset to an optimum position during test at the factory and should not normally require adjustment in the field. However, if difficulty is experienced with over-sensitivity, due for example to static discharge, this control should be rotated in an anti-clockwise direction.

Alternatively if trouble is experienced with external devices being used to try and influence the machine, the sensitivity can be increased. In case of difficulty the typical normal setting is about half way.

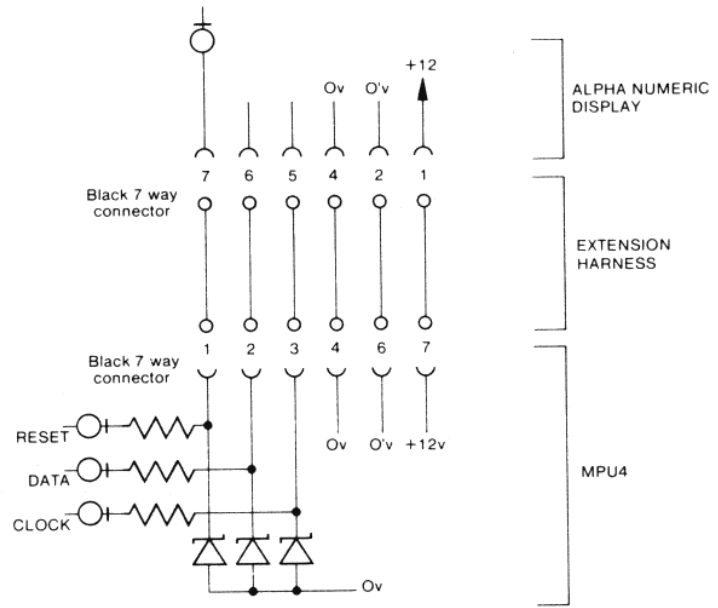


FIGURE 23
ALPHA NUMERIC DISPLAY
CIRCUIT

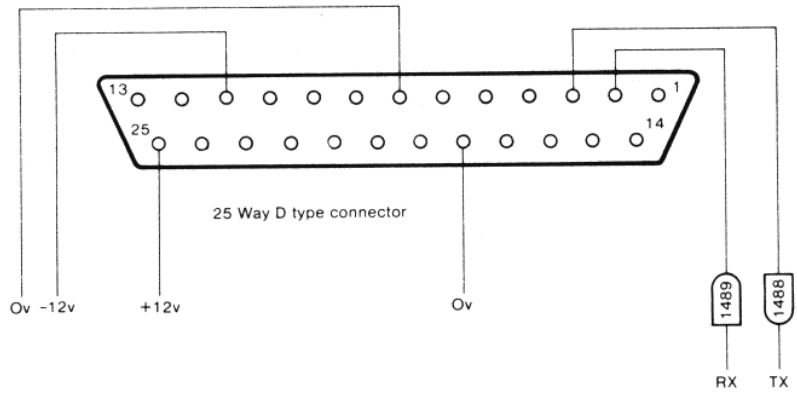


FIGURE 24
DATAPORT CONNECTION
(From MPU4)

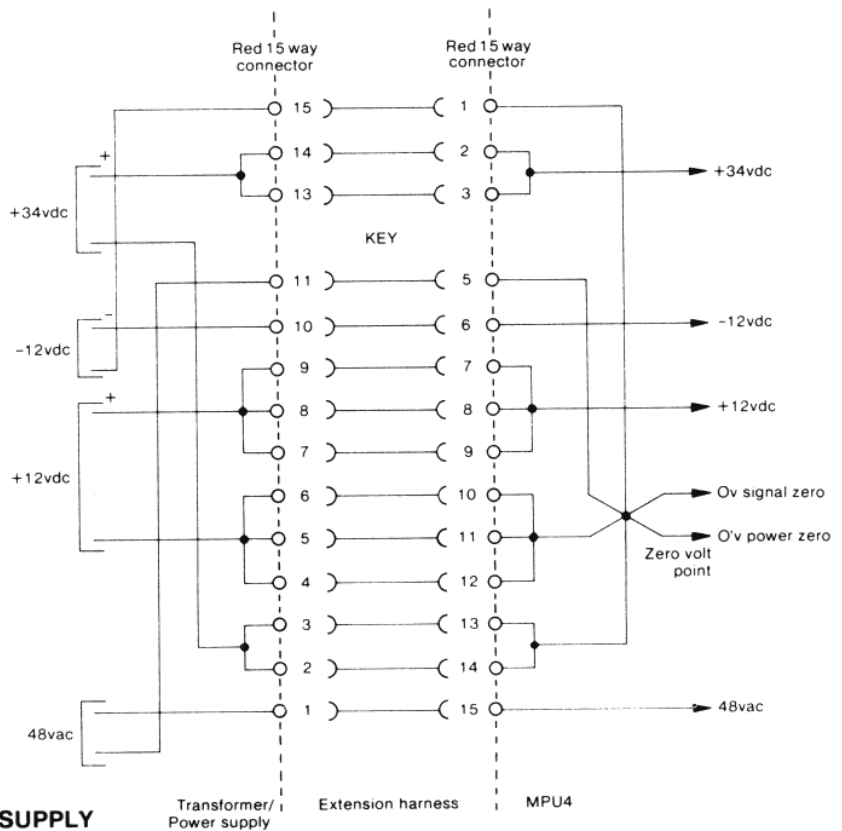


FIGURE 25
CONNECTIONS FROM
TRANSFORMER/POWER SUPPLY

2.5.16 AUDIO CIRCUIT

The MPU4 contains a complex sound generator and audio amplifier which drive a loudspeaker positioned with the machine cabinet. This generator is capable of producing a variety of sophisticated jingles and noises under program control. The volume of this audio can be adjusted by a control so labelled on the MPU4, but cannot be turned below a preset minimum level. In the case of an alarm, the associated warning audio bypasses the volume control and cannot be adjusted.

2.5.17 MEMORY

The MPU4 contains a large non-volatile memory which is able to retain its data when the supply is interrupted. This permits the status of credit and other game aspects to be preserved. Additionally sophisticated metering, data logging and facilities like "Linewriter" can easily and economically be provided.

To ensure the integrity of the data especially in sensitive areas such as credit or winnings, parity checking is employed. If an error is detected then the data is reset to zero.

In the case when the memory requires to be cleared, for example of unwanted credit the following procedure should be followed:

- i) Switch machine on with door switches closed.
- ii) Open a door switch.
- iii) Switch machine off.
- iv) Close door switch(es).
- v) Switch machine on. Credit should read zero.

Some parts of the memory cannot normally be cleared, for example long term metering locations. These can only be reset to zero by running a special "Memory Clear" program module in the MPU4. All machines and spare units have this program run before despatch from the factory.

2.6 THE PROGRAM MODULE

2.6.1 GENERAL

The control units fitted into any type of MPU4 based machines are identical and interchangeable.

The functionality particular to different models of machine is determined wholly by the Program Module.

The Program Module consists of a black plastic box, about the size of a cigarette packet and with a connector at one end. The module mates into a receptacle in the top cover of the MPU4 and is latched into position.

Whenever the module is inserted or removed from the MPU it is essential to disconnect the machine from the mains supply. Failure to do so is likely to result in electrical damage to both the module and the MPU4.

2.6.2 PROGRAM MODULE IDENTIFICATION

A label on the side of the program module gives the following information:

- i) Machine name.
- ii) Program version number.
- iii) Program module serial number.

In addition, on initialisation of the machine after power on, the name and version number of the program are displayed on the alphanumeric display.

2.6.3 PROGRAM MODIFICATIONS

During the life of a Fruit Machine it is possible that there will be a number of occasions when it is necessary or desirable to modify the program used to control the machine function.

Whilst every attempt is made to minimise these modifications in such a competitive industry with short development time scales, it is inevitable that problems will arise.

To provide a means of easily distinguishing important from minor modifications Barcrest use a two tier version numbering system. The first number represents the critical version number and the second, separated by a decimal point the non-critical version number, e.g. SS6.0, SS6.1, SS7.0 etc.

CRITICAL CHANGES

These are changes which may be considered necessary for the equipment to function in a correct, effective and secure manner. For example these would include:



FIGURE 26
METER PANEL CIRCUIT



FIGURE 27
CONNECTIONS TO MARS MS 111, 125. (or similar electronic coin mech.)

Removal of major software bugs.
 Prevention of potential cheat conditions.
 Major enhancements in the effectiveness of the game.

Barcrest will inform all interested parties by means of Technical News Letters, of any critical changes. Although these modifications are likely to be of a significant nature, it is for each individual Customer to judge if it is necessary to update his equipment. The critical version number will commence at 1 for each machine and be incremented for each critical change.

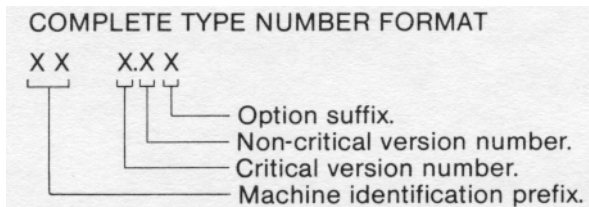
NON-CRITICAL CHANGES

These are changes of a minor nature and not considered to be essential to the correct functioning of equipment. In many cases these modifications will be for our internal purposes.

For example these could include:

- Minor software bugs.
- Changes to the out-of-credit display.
- Accommodation of a different prom configuration.

Under normal circumstances it is not expected that Customers will require to be informed of this class of modification. The non-critical version number will commence at .0 for each critical version number.



The machine identification prefix will always comprise two alphabetic characters, unique to a machine type. (These will also be used in the Dataport machine code).

The option suffix when applicable will comprise one or more alphabetic characters.

Some of the more common options are as follows:

- D = Dataport with protocol.
- H = Higher payout %.
- L = Lower payout %.

2.6.4 PROMS

There are two types of program module for the MPU4. The first type could contain between one and four 64K (2764) or 128K (27128) UV erasable PROMS. (Programmable read only memories) which contain all the firmware necessary to the application. This first type has now been replaced by a second that can contain between one and three 64K (2764) or 128K (27128) or 256K (27256) or 512K (27512).

The proms are contained in 28 pin sockets mounted on a printed circuit board within the module program card. If required proms can be removed and replaced in the field. The devices are identified by a label which gives the version and the position of each PROM in the program card, P1, P2 and P3. These together with the orientation are clearly identified on the program card.

The four socket program card can only accept either 4 x 64K or 4 x 128K PROMS. The prom type is selected by means of a number of soldered wire links as shown in Fig.29. The new three socket program card can be configured to take any mixture of PROMS. The location of the links to be fitted are shown in Fig.29.1.

The following table gives the links to be fitted for all possible prom configurations:

PROGRAM SIZE	POSSIBLE CONFIGURATION			LINKS TO BE FITTED
	P1	P2	P3	
32K	32K	-	-	L 1 b, L3b
40K	32K	16K	16K	- L1a, L2a, L3a, L4a, L7
48K	32K	8K	8K	L 1 b, L2b, L3b, L4a
56K	32K	16K	16K	L 1 a, L2a, L3a, L4a, L5a, L7
60K	32K	16K	16K	L 1 b, L2b, L3b, L4a, L5a, L7
	32K	-	32K (28K)	L 1 b, L2d, L3b, L5b, L6
	32K	16K	16K (12K)	L 1 b, L2b, L3b, L4a, L5a, L6, L7
	-	-	64K (60K)	L 1 c, L2d, L5b, L6

The figure in brackets is the actual memory size usable in P3.

- The 8K prom is a 2764
- The 16K prom is a 27128
- The 32K prom is a 27256
- The 64K prom is a 27512



FIGURE 28
CONNECTIONS TO COIN LEVEL DETECTOR



FIGURE 29
MPU4 MKI PROGRAM MODULE PCB



FIGURE 29.1
MPU4 MKII PROGRAM MODULE

Each time the MPU4 is initialised after power on, it performs a parity check on the program module. This consists of adding together all the data contained in each prom and comparing the result with a checksum also contained within the proms. If an error is found an alarm condition is entered and an appropriate error message is displayed on the alphanumeric display. For example "P2 CHECKSUM ALM" would indicate a checksum error has been detected in the PROM in position P2 on the program card.

2.6.5 PROM REPLACEMENT

- i) Ensure power is removed from the machine.
- ii) Remove the Program Module.
- iii) Remove the two self-tapping screws split module in half and remove program card.
- iv) Ensure PROMs to be exchanged are of the same capacity, 2764 or 27128.
- v) Carefully prise PROMs from socket using a small screw driver alternately under each end.
- vi) Fit replacement PROMs ensuring device labelled P1 is fitted in socket identified P1 etc.
Ensure orientation is correct; semi circular notch at end of proms should face away from edge connector on card.
Care must be taken to ensure pins do not get bent underneath devices instead of inserted into socket.
- vii) Change version number on program module label to correspond with new proms.
- viii) Refit case and mate module with MPU4.
- ix) Power machine on and test.

2.6.6 CHARACTERISER

The characteriser is a special semiconductor device which resides in each program module. This device is peculiar to a model of machine.

For a program module to work it must have a matching set of proms and characters. All versions of a program will normally run with the same characteriser. But proms for game A will not work with a characteriser for game B and vice-versa.

On initialisation the program checks for the correct characteriser. If a conflict is detected an alarm mode is entered and a "CHARACTERISER ALM" message is shown on the alphanumeric display.

2.7 FUSES AND LAMPS

Types of fuses and lamps used in a typical MPU4 machine are as follows:

PURPOSE	RATING	SIZE	LOCATION
+12V	7.5 amp anti-surge	1¼ inch	Transformer/Power Supply.
+34V	7.5 amp anti-surge	1¼ inch	Transformer/Power Supply.
48V	5 amp fast-blow	1¼ inch	Transformer/Power Supply.
-12V	250mA fast-blow	20mm	Transformer/Power Supply.
+12V	3 amp fast-blow	1¼ inch	Mars Interface Harness.
240V	3 amp fast-blow	1 inch	13 amp mains plug.
Lamps -	12V 1.2 watt 1 0mm wedge base. On current machines.		
	12V 2.2 watt 1 0mm wedge base. On older machines.		

2.8 ELECTRONIC COIN MECHANISMS

The MPU4 has the ability to easily interface to electronic coin mechanisms and handling systems through the two Auxiliary ports. A typical application is shown in Fig 27 where a MARS, MS111, 125 or any other mechanism using a compatible interface is connected to AUX2. The individual coins are enabled or inhibited (locked out) by four signals at TTL levels.

A low signal (less than 0.8 volts) will cause the coin to be enabled and a high signal (greater than 2.4v) will inhibit. When a coin is accepted the mechanism gives a 12 volt pulse on one of four output pins for a duration of approximately 100ms. To convert these pulses to TTL levels acceptable to the AUX port a potential divider consisting two resistors is included in the interface harness.

Also included in the harness is a 3 amp fuse in series with the +12v supply to the mechanism.

Mars can supply (also available through Barcrest Service Department) a very useful "MS111 Field Test Box".

This is designed to connect between the interface and the mechanism and can much simplify fault finding within this area.

2.9 TUBE LEVEL DETECTORS

Most machines using slide payout devices have one or more level sensors on the payout tubes. These devices can be present for a variety of reasons which are outlined in section 1.14.

On MPU4 machines the Starpoint 2CLD Coin Level Detector is frequently used for these purposes. This detector uses a combination of electronics and mechanics to provide a solution.

A slot in the payout tube with the aid of a flexible retainer give mounting and location for the device.

A finely balanced operating lever protrudes through the slot and into the tube.

The position of this lever makes or breaks a photo electric circuit within the detector. Fig 28 shows the circuit diagram.

The 2CLD is connected to the MPU4 by the main harness. The output from the device looks and is treated as a switch input by the input multiplexer. The detector can be tested as any other input device or switch using the Self Test routine see section 1.5. When more than one of these devices is used an additional test is normally provided to ensure connections to the detectors are not crossed.

2.10 ALARMS

The MPU4 system is equipped with a sophisticated alarm system. This is designed to highlight malfunctions in the machine, either due to a failure of some type or suspected tampering.

On detecting an alarm condition the system will normally:

- i) Halt normal operation
- ii) Lockout all coins.
- iii) Sound a warning audio.
- iv) Display an error message on the alphanumeric display.
- v) Write the occurrence to the alarm log.

The alarm condition can normally be cleared by switching the machine off and on. The alarm log is a means of recording the reasons for the previous sixteen alarm conditions. This can provide a useful pointer to the service engineer who can use this historic information to quickly identify the problem. To access the alarm log see the section on Electronic Metering (1.9).

SELF TEST ALARMS

Each time the MPU4 is initialised it automatically tests several aspects of its own hardware. If an error is detected then one of the following messages will be displayed:

PIA HARD TST ALM	P.I.A. test failure. (Peripheral interface adapter).
PTM HARD TST ALM	P.T.M. test failure. (Programmable timer module).
RAM HARD TST ALM	R.A.M. test failure. (Random access memory).
NO IRQ PULS ALM	I.R.Q. not running. (Interrupt request).
BAD IRQ PULS ALM	I.R.Q. out of spec.
NO DATAPORT COMM	Datapak not fitted or disconnected.

In the event of one of the above conditions being displayed, switch the machine off and on. If the alarm persists, replace the MPU4. Be sure to clearly identify the problem on returning the unit to Barcrest Service department.

While the machine is operating it checks the operation of the multiplex which can result in the following alarms:

MUX DRIVES ALM	Multiplex row transistor shorted.
MUX SELECTS ALM	Multiplex col transistor shorted.
MUX SELECT A ALM	Multiplex col transistor shorted.
MUX SELECT B ALM	Multiplex col transistor shorted.

CHECKSUM ALARMS

Each time the MPU4 is initialised it automatically checks the proms and characteriser contained within the program module. If a discrepancy is detected then one of the following messages is displayed on the alphanumeric display:

P1 CHECKSUM ALM	EPROM 1 checksum error.
P2 CHECKSUM ALM	EPROM 2 checksum error.
P3 CHECKSUM ALM	EPROM 3 checksum error.
P4 CHECKSUM ALM	EPROM 4 checksum error.
BAD CHARACTR ALM	Characteriser error.

All the above messages indicate a problem in the program module which will require to be replaced with a similar unit.

REEL ALARMS

See section 2.3.9.

12V METER ALARMS

The drive circuitry for the electro-mechanical meters is equipped with a current sensing facility which can detect if a meter is being correctly driven. If a problem is detected the alarm mode is entered and one of the following messages is displayed.

METER SENSE ALM	Current being sensed when no meters are being driven.
XXXXXXXX MET ALM	No current being sensed when a specific meter is being driven. (XXXXXXXX will read a specific meter e.g. CASH IN).

COIN ALARMS

The MPU4 monitors signals from the coin mechs and will enter the alarm mode under certain error conditions:

XXX COIN SW ALM	The input signal for a specific coin (XXX) is held closed or has been held closed for a period greater than 640mS.
XXX LOCKED ALM	An input signal for a specific coin (XXX) has been received when inhibited (locked out). (XXX would indicate for example 10P or 20P etc.)
BAD COIN ALM	This coin is not valid for this machine.

These alarm conditions indicate a problem with the coin mechanism, for example a coin switch jammed closed. Alternatively it could indicate an attempt has been made to defraud the machine for example by "fishing".

2.11 FAULT FINDING

The MPU4 system is equipped with a number of mechanisms to assist and simplify fault finding for the field engineer. The self test routine (see section 1.5) provides a quick and easy means of ensuring all major aspects are functioning correctly. It is always a good discipline to automatically run this test in the first instance.

The extensive system monitoring and self diagnostics directly indicate problems through the alphanumeric display and alarm system (see section 2.10). The alarm log (see section 1.9) permits the alarm history to be easily determined or confirmed. This manual assumes that faults in the field will normally be traced and rectified at assembly level. For example if the problem is discovered to be a defective MPU4, the complete unit will be replaced. The faulty unit being returned to Barcrest or other Service department for repair at component level.

2.11.1 MEASURING VOLTAGES

It is frequently useful when fault finding to use a voltmeter to help determine the source of the problem. This handbook indicates in a number of places the typical voltages expected at various points in a normally working machine. All these voltages are given with reference to 0v.

Two convenient places for connecting the voltmeter common to the 0v signal are as follows:

- i) The test pin identified as "0v" on the reel assembly backplane.
- ii) The aluminium heatsink forming the rear panel of the MPU4 box.

All MPU4 supplies are isolated from mains earth.

2.11.2 COMPONENT SUBSTITUTION

Component substitution is a useful and convenient technique to pin point or confirm the faulty item. Where a spare component is not to hand a known good similar component can be temporarily substituted from another situation within the machine. If for example one of the reels refuses to spin.

The fault could lie with the stepper motor or the MPU4 drive circuits. By exchanging the suspect motor connections with that of an adjacent motor on the backplane and observing if the fault follows the motor the culprit can be accurately determined. Components where this technique can normally be used without any additional spares are as follows:

- Lamps
- Lamp Holders
- Switches
- Payout Solenoids
- Stepper Motors
- Reel Photo Boards
- Lockout Solenoids
- Fuses
- Level Detectors

2.11.3 SOME POSSIBLE PROBLEMS AND POSSIBLE SOLUTIONS

CAUSE	COMMENT
MACHINE NOT INITIALISING	
No mains supply or 12V fuse blown	Supply indicator on MPU4 lit?
Program Module defective	Try substituting any other MPU4 module.
MPU4 defective	Try replacement.
MACHINE NOT PAYING OUT	
Defective payout slide	Try substitution.
Door switches not operating	Are cash and back doors closed?
Incorrect reel bands	Check idents on band leader.
Incorrect program module	Check module label.
50V fuse blown	Try replacement.
MPU4 defective	Try replacement.
Overtight clip on payout tube	Try slackening.
INTERMITTENT NO PAYOUT	
Coins not filling payout tube reliably	Try re-alignment.
Payout slide springs weak	Try shortening.
Intermittent connections on solenoid	Try substitution.
Reset sensitivity too high	Try turning lower.
Not accepting payout coin	Test for correct coin acceptance.
Coin tube sensors not operating	Try substitution.

NO COIN CREDIT (ON COIN ACCEPTANCE)

Machine in refill mode

Check refill switch.

Defective coin switch

Try replacement.

Static resetting machine

Adjust reset sensitivity.

Electronic mech defective

Try replacement.

MPU4 defective

Try replacement.

MACHINE NOT ACCEPTING COINS

SOV fuse blown

Try replacement.

Coin mech out of adjustment

Try substitution.

Lockout defective

Ensure lockout energised.

Low coin level in payout Tubes

Try manually operating level detector.

Level detector defective

Try substitution.

Mars fuse (in interface harness)

Try replacement.

Not communicating with Data Capture unit

Try with door open.

Electronic mech defective

Try replacement.

MPU4 defective

Try replacement.

INTERMITTENT RESET

Static resetting machine

Adjust reset sensitivity.

Interference resetting machine

Adjust reset sensitivity.

Low mains supply

Change transformer to 220V.

Intermittent connection (especially in 50V circuits)

Try and isolate by elimination.

MPU4 circuits not isolated from earth

Test with meter.

REEL ALARM ON INITIALISATION

Reel drum sticking

Ensure reels are free to rotate.

Lead disconnected

Check motor and photo leads.

Defective motor

Try substitution.

Defective photo detector

Try substitution.

MPU4 defective

Try replacement.

INTERMITTENT REEL ALARMS

Reel drum sticking

Ensure reels are free to rotate.

Incorrect motor alignment

See Section 2.3.4

Early software release

* Ensure latest program version.

Low supply voltage

Change transformer tap to 220V.

* NOTE: On early machines low supply voltage can cause intermittent reel alarm problems. This has now been corrected on current versions.

2.11.4 MPU4 PINOUT

The voltages refer to the expected reading with a 20k/V moving coil meter on the various pins with the machine in a static condition.

Examples:

- j) 0 to +5vdc means that any voltage between 0 and +5vdc could be expected on the pin.
- ii) 0 or +5vdc means that a voltage of approximately 0v or +5vdc only should be present on the pin.
- iii) +5dc means that only a voltage of approximately the specified value should be present on the pin.

POWER IN -RED 15 WAY

PIN	FUNCTION	VOLTAGE
1	-12v return	0v
2	+34v supply	+34vdc
3	+34v supply	“
4	Key	
5	48v return	0v
6	-12v supply	-12vdc
7	+12v supply	“
8	+12v supply	“
9	+12v supply	“
10	+12v return	0v
11	+12v return	“
12	+12v return	“
13	+34v return	“
14	+34v return	“
15	48v supply	48vac

ALPHA DISPLAY -BLACK 7 WAY

PIN	FUNCTION	VOLTAGE
1	Reset display	0 to + 5vdc
2	Data	“
3	Clock	“
4	Signal 0v	0v
5	Key	
6	Power 0v	0v
7	+12v supply	+12vdc

TRIACS- WHITE 11 WAY

PIN	FUNCTION	VOLTAGE
1	48v supply	48 vac
2	Power 0v	0v
3	Triac drive	1 or 48vac
4	Triac drive	“
5	Triac drive	“
6	Triac drive	“
7	Key	
8	Triac drive	1 or 48vac
9	Triac drive	“
10	Triac drive	“
11	Triac drive	“

SWITCH INPUTS 1 -ORANGE 19 WAY

PIN	FUNCTION	VOLTAGE
1	Input	0 to +5vdc
2	Input	“
3	Input	“
4	Input	“
5	Input	“
6	Input	“
7	Input	“
8	Input	“
9	Input	“
10	Input	“
11	Input	“
12	Input	“
13	Input	“
14	Key	
15	Input	0 to +5vdc
16	Input	“
17	Input	“
18	Enable	“
19	Enable	“

SWITCH INPUTS 2- BLACK 19 WAY

PIN	FUNCTION	VOLTAGE
1	Input	0 to 5vdc
2	Input	"
3	Input	"
4	Input	"
5	Input	"
6	Input (Test switch)	"
7	Input (Refill switch)	"
8	Input (Door switch)	"
9	Input (Cancel switch)	"
10	Input (Hold D switch)	"
11	Input (Hold C switch)	"
12	Input (Hold B switch)	"
13	Input (Hold A switch)	"
14	Input	"
15	Input	"
16	Key	
17	Input (Start switch)	0 to 5vdc
18	Enable	"
19	Enable	"

ELM METERS -YELLOW 10 WAY

PIN	FUNCTION	VOLTAGE
1	Meter drive	+12vdc
2	Meter drive	"
3	Meter drive	"
4	Meter drive	"
5	Meter drive	"
6	Meter drive	"
7	Meter drive	"
8	Meter drive	"
9	Key	"
10	Meter common	+12vdc

STEPPER MOTORS -RED 19 WAY

PIN	FUNCTION	VOLTAGE
1	+12v supply	+12vdc
2	Reel D drive	0 to 12vdc
3	Reel D drive	"
4	Reel D drive	"
5	Reel D drive	"
6	Reel C drive	"
7	Reel C drive	"
8	Reel C drive	"
9	Reel C drive	"
10	Reel B drive	"
11	Reel B drive	"
12	Key	"
13	Reel B drive	0 to +12vdc
14	Reel B drive	"
15	Reel A drive	"
16	Reel A drive	"
17	Reel A drive	"
18	Reel A drive	"
19	+12v supply	+12vdc

REEL PHOTO -GREEN 9 WAY

PIN	FUNCTION	VOLTAGE
1	+5v supply	+5vdc
2	LED drive	+1 or +12vdc
3	Signal 0v	0v
4	Key	
5	Reel D input	+3.5vdc
6	+12v supply	+12vdc
7	Reel C input	+3.5vdc
8	Reel B input	"
9	Reel A input	"

AUX 1 -WHITE 12 WAY

PIN	FUNCTION	VOLTAGE
1	+12v supply	+12vdc
2	Power 0v	0v
3	Signal 0v	“
4	Key	
5	Input/output (A7)	0 to +5vdc
6	Input/output (A6)	“
7	Input/output (A5)	“
8	Input/output (A4)	“
9	Input/output (A3)	“
10	Input/output (A2)	“
11	Input/output (A1)	“
12	Input/output (A0)	“

AUX 2- BLACK 12 WAY

PIN	FUNCTION	VOLTAGE
1	+12v supply	+12vdc
2	Power 0v	0v
3	Signal 0v	“
4	Input/output (B7)	0 to +5vdc
5	Input/output (B6)	“
6	Key	
7	Input/output (B5)	0 to +5vdc
8	Input/output (B4)	“
9	Input/output (B3)	“
10	Input/output (B2)	“
11	Input/output (B1)	“
12	Input/output (B0)	“

LAMP SELECTS -BLUE 17 WAY

PIN	FUNCTION	VOLTAGE
1	Lamp select (7)	0 to +34vdc
2	Lamp select (6)	“
3	Lamp select (5)	“
4	Lamp select (4)	“
5	Lamp select (3)	“
6	Key	
7	Lamp select (2)	0 to +34vdc
8	Lamp select (1)	“
9	Lamp select (0)	“
10	Lamp select (7)	“
11	Lamp select (6)	“
12	Lamp select (5)	“
13	Lamp select (4)	“
14	Lamp select (3)	“
15	Lamp select (2)	“
16	Lamp select (1)	“
17	Lamp select (0)	“

7 SEG. DISPLAYS -YELLOW 17 WAY

PIN	FUNCTION	VOLTAGE
1	Enable (0)	0 to +5vdc
2	Enable (1)	“
3	Enable (2)	“
4	Enable (3)	“
5	Key	
6	Enable (4)	0 to +5vdc
7	Enable (5)	“
8	Enable (6)	“
9	Enable (7)	“
10	Segment a drive	0 to +5vdc
11	Segment b drive	“
12	Segment c drive	“
13	Segment d drive	“
14	Segment e drive	“
15	Segment f drive	“
16	Segment g drive	“
17	D.P. drive	“

LAMP DRIVES -GREEN 17 WAY

PIN	FUNCTION	VOLTAGE
1	lamp drive (A0)	0 to +34vdc
2	lamp drive (A1)	“
3	lamp drive (A2)	“
4	lamp drive (A3)	“
5	lamp drive (A4)	“
6	lamp drive (A5)	“
7	Key	
8	lamp drive (A6)	0 to +34vdc
9	lamp drive (A7)	“
10	lamp drive (B0)	“
11	lamp drive (B1)	“
12	lamp drive (B2)	“
13	lamp drive (B3)	“
14	lamp drive (B4)	“
15	lamp drive (B5)	“
16	lamp drive (B6)	“
17	lamp drive (B7)	“

POWER OUT - BLUE 11 WAY

PIN	FUNCTION	VOLTAGE
1	48v supply	48vac
2	Power 0v	0v
3	Speaker	“
4	Signal 0v	“
5	Signal 0v	“
6	Power 0v	“
7	+12v supply	+12vdc
8	Key	
9	-12v supply	-12vdc
10	+34v supply	+34vdc
11	Aerial	0v

NOTES