

**ROMSTAR™ inc.**

# F1 DREAM

## INSTALLATION MANUAL

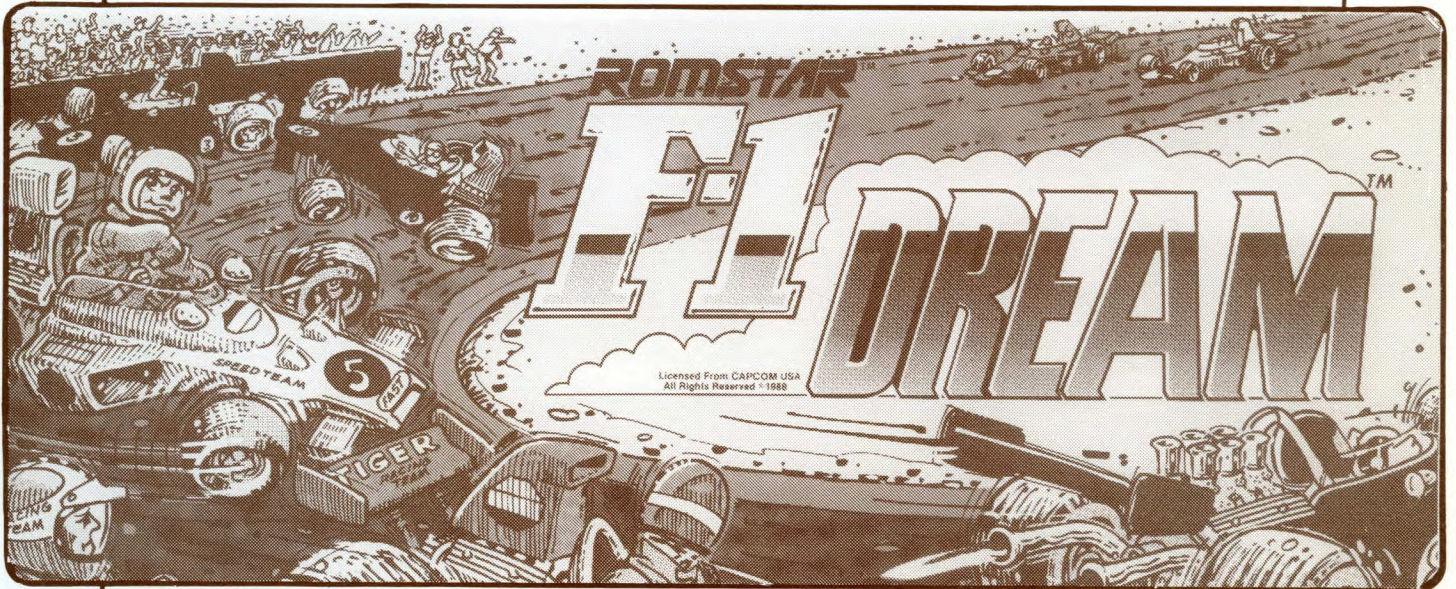

Romstar, Inc.

22857 Lockness Ave., Torrance, CA 90501  
Phone (213) 539-2744 Fax (213) 539-3626

Licensed From CAPCOM™ CORPORATION  
All Rights Reserved ©1988

## WARRANTY, REPAIR AND RETURN POLICY

1. \*45 DAY FULL PARTS WARRANTY.
2. \*60 DAY FULL ELECTRONICS WARRANTY (SEE RMA BELOW).
3. MINIMUM \$40.00 SERVICE CHARGE FOR ALL NON-WARRANTY REPAIRS OR RETURNS. FOR ALL PCB SERVICING RETURN TO ROMSTAR AND ALL ROMSTAR DECALS MUST REMAIN ON PCB.
4. **ANY UNAUTHORIZED NON-FACTORY REPAIR OR ATTEMPTED REPAIR VOIDS WARRANTY.**
5. ALL REPAIR WORK **MUST** BE AUTHORIZED BY ROMSTAR FOR EACH PCB.

(\*ALL WARRANTY PERIODS BEGIN ON THE DATE OF PURCHASE FROM ROMSTAR)

### RETURN MERCHANDISE AUTHORIZATION — (RMA)

1. ALL RETURNED MERCHANDISE MUST HAVE AN RMA NUMBER CLEARLY VISIBLE ON THE OUTSIDE OF THE PACKAGE.
2. ALL RMA NUMBERS MUST BE OBTAINED FROM ROMSTAR BY AN AUTHORIZED ROMSTAR DISTRIBUTOR. (PLEASE HAVE ROMSTAR SERIAL NUMBER AVAILABLE WHEN CALLING FOR AN RMA #).
3. **ALL PC BOARDS RETURNED TO ROMSTAR WITHOUT AN RMA NUMBER WILL NOT BE ACCEPTED.**
4. ROMSTAR WILL SHIP ADVANCE REPLACEMENT BOARDS TO DISTRIBUTORS OR AT DISTRIBUTORS REQUEST, DROP-SHIP BOARDS DIRECT TO THE OPERATOR.
5. ADVANCE REPLACEMENT BOARDS WILL BE BILLED TO THE DISTRIBUTOR UNTIL RECEIPT OF A RETURNED BOARD BY ROMSTAR AT WHICH TIME A CREDIT WILL BE ISSUED.
6. ALL REPAIRS AND/OR REPLACEMENTS WILL BE SHIPPED BY ROMSTAR WITHIN 24 HOURS OF RECEIPT OR REQUEST. (SUBJECT TO AVAILABILITY OF BOARDS).
7. FOR ANY ROMSTAR PRODUCT PURCHASED AFTER 3/1/86, A ROMSTAR WARRANTY CARD MUST BE ON FILE FOR EACH BOARD TO FACILITATE REPAIR & RETURN.
8. ROMSTAR WILL REPAIR OR REPLACE ROMSTAR PCB's FOR A MINIMAL CHARGE FOR A PERIOD OF 1 YEAR. (SUBJECT TO AVAILABILITY OF BOARDS OR TIME REQUIRED TO REPAIR PCB.)

\*NOTE: ATTEMPTED REPAIR USUALLY INCREASES THE TIME AND COST OF REPAIR.

## Installing Your

# F1 DREAM

## New Game Package

### Table of Contents

New Game Package Contents .....	2
Power and Monitor Requirements .....	2
Factory Settings .....	3
Recommended Tools and Supplies .....	4
Installation Procedures .....	5
Coin Meter Diagram .....	10
Monitor Sync Tips .....	11
Control Panel Positioning .....	12
Dip SW Diagram .....	13
In Case Of Difficulty .....	14
Main Harness Connections .....	15 & 16

### NEW GAME PACKAGE CONTENTS

DESCRIPTION	PART #	DESCRIPTION	PART #
1 Main Printed Circuit Board (PCB)	5401	2 White Player Button	0231
1 Monitor Bezel	5408	1 Marquee	5403
1 PCB Feet Assembly	0524	1 Control Panel Overlay	07
1 Connecting Wire Harness (Jamma)	5405	1 Plex Control Cover	0271
1 Eight-Way Joystick	0210	1 Set Side Graphics	5406
6 Player Button Assemblies		1 Set Play Instructions & Function Labels	5404
2 Red Player Button	0229	1 Installation Manual	5402
2 Blue Player Button	0233		

**Note:** Replacement accessories available through your exclusive **Romstar** distributor

POWER REQUIREMENTS		MONITOR REQUIREMENTS
+5 VDC	7 amp minimum	Horizontal Mount Raster Scan
+12 VDC	1 amp minimum	Negative Composite Sync

# **ROMSTAR™ INC.**

## **Invites You To Use**

OUR PHONE OR FAX NUMBER FOR  
SERVICE INFORMATION CONCERNING THIS GAME, OR ANY  
OTHER ROMSTAR GAME YOU NOW HAVE ON LOCATION.

CALL US FOR PROMPT, COURTEOUS  
ANSWERS TO YOUR PROBLEMS.

### **ROMSTAR, INC.**

22857 LOCKNESS AVENUE • TORRANCE, CALIFORNIA 90501

TECH. DEPT.

PHONE (213) 539-2744

FAX (213) 539-3626

### **\*FACTORY SETTING PLEASE SET THE F1 DREAM PCB AS FOLLOWS:**

<b>DESCRIPTION</b>	<b>SETTING</b>	<b>ADJUSTMENT</b>	<b>POSITION</b>	<b>DIP BANK</b>
CONTINUE MODE	WITH	OFF	8	B
TEST MODE	NORMAL		7	A
VER.	USA	ON	7	B
COIN 1	1 COIN 1 PLAY	OFF/OFF/OFF	4/5/6	A
COIN 2	1 COIN 1 PLAY	OFF/OFF/OFF	1/2/3	A
F1 POINT	12 POINTS	OFF/OFF	4/5	B
DIFFICULTY	NORMAL	OFF	6	B
TYPE	UPRIGHT	ON	3	B

# Before You Get Started . . . Stop!

1. Does your **new game** package include all listed parts? (Is it complete?)
2. Is the game you have chosen to transform able to supply all the required voltages for the **new game**?  
**Note:** Some games, (i.e. Ms. Pac Man, Galaxian, etc.) regulate their voltages on the main P.C.B. This makes the existing power supply inefficient. These games will require a change in power supply for your **new game**. Many game supply houses can offer you a switching regulated power supply for a relatively low cost.
3. Is the monitor configuration compatible? In most games it is rather difficult to change the monitor from a vertical mount to a horizontal mount. We recommend you choose a game cabinet with the same mount as your **new game** requires.
4. Do you have the necessary tools? (See the recommended tool list)

## Caution

### F.C.C. Regulation Compliance

Operation of this equipment in a residential area is likely to cause interference — in which case, the user at his own expense, will be required to take whatever measures may be required to correct the interference.

## Recommended Tools and Supplies

ROMSTAR **new game** package.

Phillips and Slot Screwdrivers

Socket Set

Enthusiastic Attitude

Wire Cutters and Strippers

Pliers or Channel Locks

Planning and Careful Thought

Electric Drill

3/32" • 1/4" • 7/16" Drill Bits

1/4" Plex Bit

1-3/16" Chassis or Sheet Metal Punch

1 1/4" Plex Hole Saw

Glass of Water and a Snack

Small File

Razor Knife and Sharp Blades

Straight Edge

Patience

Common Sense

Painting Supplies (if you do your own painting)

Paint Brush and Paint (don't forget the primer)

Paint Roller and Pan

Sand Paper

Putty Knife and Wood Putty

A Good Night's Sleep

Staple Gun and Staples

Soldering Iron and 60/40 **Resin Core** Solder

Vacuum Cleaner

Assorted Fastening Hardware

Shrink Tubing: 3/32" • 1/8" • 3/16"

Masking Tape

3 1/2" OR 4" Wire Ties

Spray Window Cleaner and Rags  
(baby diapers work GREAT!)

## Dip Switch Tables

### Optimize Your Profits

**Thorough Research shows that two and a half minute games both satisfy players and also keep the quarters flowing.**

If games aren't running about two and a half minutes long, then collections probably aren't at their peak. You'll want to tailor your game to your location. The trick is to adjust a few DIP switches. (See the chart in this book.) It's easy!

# Installation Procedures

## Something To Think About

Your final product will be a **new game**.

You have made a wise decision to transform a game that has seen better days in the all important cash box into a **new game**. This is by far the most cost effective alternative to maximize the return of your initial investment. All you provide is the cabinet with a power supply and a monitor. Oh yes, you will need a touch of elbow grease. And that's it! We provide the rest. The end result is . . . a **new game** at a very low cost.

**Fact:** Spend a little time on the cabinet's appearance (i.e. marquee, control panel and cabinet graphics). With a little paint, some wood putty and new lights, you will raise the profits of any game. . . especially with the introduction of a **new game** package.

The **new game** look should always apply to the inside of your game as well as the outside. A few wire ties and shrink tubing on your harness; some fastening hardware on your subassemblies and a sweep with the ol' vacuum cleaner will ensure that unnecessary *glitches* do not occur.

**Remember:** You are creating a **new game**.

If you have any questions or just need some advice on any of your **new game** transformations, don't hesitate in giving a member of our technical staff a call.

## Let's Get Our Hands Dirty

### Preparing the Original Game for the New Game

Remove the following:

1. Main logic board(s)
2. Control panel
3. Monitor plexiglass
4. Monitor Bezel
5. Marquee
6. Graphics

I would recommend painting your cabinet to give it a fresh new look. You may consider having an auto body shop take care of your painting needs.

If your cabinet has wood grain sides; remove old graphics and adhesive (adhesive may be removed with **lacquer** thinner).

If you intend to use your original plexiglass, be sure it is in mint condition or it should be replaced.

Thoroughly clean out your cabinet.

# Time To Install Your New Goodies

**Before You Start . . . Remember DO NOT  
Do This Work With The Power On!**

## **Logic P.C.B.**

Mount the logic board securely (away from power supply).

- A Mark and drill pilot holes (3.32").
- B Install the P.C.B. into cabinet. Use feet and spacers supplied and adjust them so that the screws will go through the holes in the cabinet.

## **Wire Harness**

Attach the wire harness connector to the main logic board. **CAUTION:** Sometimes the connector is not keyed and it is very easy to install it reversed on the logic board. Even if it is keyed, always **triple check** to be sure the wire inputs were connected correctly to the connector and the connector to the logic board.

## **Connecting the Wire Harness to the Existing Wires**

When you hook up the control panel, power supply, monitor or other subassemblies that remain in the game cabinet to your new wire harness, try and use their existing secondary connectors.

1. Cut the original wire approximately three inches from the original connector. Strip off about one half inch of insulation.
2. Solder the new wire designated for that position to the original wire you just stripped.

**Warning:** DO NOT JUST TIE THE WIRES TOGETHER. THIS CAN CAUSE NAGGING INTERMITTENT PROBLEMS THROUGH LOOSE CONNECTIONS OR OXIDATION OR BOTH. **Always take the time to do it right.**

3. Melt shrink tubing around all your in-line wire connections. Do not use electrical tape. Tape could unravel over a period of time due to the cabinet heat and cause you a great deal of trouble.
4. Use wire tie wraps, and secure the cable to the cabinet whenever it seems necessary. Remember this is a **new game**, not a sloppy conversion.

## **Power Wires**

1. Connect the wires that are designated for your power supply. You will need a supply of +5V, +12V & ground. Your **new game** package may not require all of the voltages that were used in the original game. Tie off any unused wires.
2. You will notice that you probably have more than one wire for each voltage. It is a good idea to use all wires supplied (double up if it is necessary). This will help to ensure that you don't overload the edge connector pins and cause them to "burn".



## Monitor Wires

You will be connecting the wires designated for the RED, GREEN & BLUE video guns along with the SYNC & GROUND wires.

### **NOTE . . . CONCERNING SYNC:**

Your **new game** only calls for one sync wire connection, this is called **composite sync** (horizontal and vertical tied together). This composite sync is also **negative**. Most monitors have supply positions for both negative and positive sync. You can check your monitor manual or call our technical department for assistance.

## Speaker Wires

Find the two wires that are designated for the speaker and hook 'em on up.

## Coin Door Wires

1. Connect the designated wires to the coin switches and meter. (See tech tips)
2. You can connect your door lamps to the unused -5V power supply. Some games have separate power outputs for the coin door lamps.
3. Be sure to clean and lubricate your old coin mechanisms. Keep the money coming in.

## GUESS WHAT?

You are almost done with the electrical connections of your **new game**. All you have left is the control panel wiring. But we are going to hold off on that for right now. We have a few other things we need to do first. So why don't you go ahead and get yourself a drink of water and stretch your legs. When you return, we can take a fresh look at your progress and then move forward.

# Smoke Test

## What Test?

Don't worry. All this means is that you are ready to apply power to the system for the first time and you pray that there will be no smoke from a simple oversight.

You are just about ready to power up the logic board. But first we need to recheck your work.

1. Carefully inspect the game for loose power wires, exposed connections and extra fastening hardware.
2. Make sure the logic board, monitor and power supply are securely fastened in place.
3. **Double check** the connectors to be sure they are wired and connected properly.
4. Set the dip switches on the logic board to the factory recommendations. (Refer to page 5.) Also, be sure you set the dip switches for "DEMO WITH SOUND". This will enable you to hear as well as see that your new P.C.B. is functional.

### Time to Apply Power:

1. Look and smell for smoke. (TURN OFF IMMEDIATELY IF ANY IS NOTICED)
2. Listen for game sounds.

If after one minute you have not heard any sounds:

- A) Check for proper dip switch settings.
- B) Adjust volume control and check speaker connections.
- C) Check the +12V power supply to the logic board.

**NOTE:** If you do get sounds, but they are a little fuzzy, switch the wires around on the speaker.

3. How is the monitor image?

A) **Is the picture in sync?**

If your picture has the top and bottom halves of the screen reversed and it will not stop rolling, change your sync polarity on the monitor. (Positive to negative (see tech tips section)).

### NOTES:

B) **Now how's your picture?**

- It it centered?
- Is it too bright or dim?
- Is it in focus?

Check your monitor manual for these adjustments. If your screen looks "off", then your **new game** transformation may have been in vain. So let's take the time to make the monitor look great.

C) **Is the picture upside-down?**

Refer to your monitor manual - switch two horizontal yoke wires and then switch two vertical wires. (Pull the pins in the connector on the monitor P.C.B. to switch them.) or check Dip Switch Tables

## Control Panel Assembly

1. Remove the buttons, joysticks and wire harness and put them aside for now. Do not remove the original panel overlay until the new holes have been drilled.
2. Mark positions on the panel for the new holes.

**ROMSTAR** supplies a clear 1/8" thick piece of plexiglass with every **new game** package to cover the control panel. We feel that your **new game** investment is well worth protecting . . . and the control panel is the first place to show wear and tear.

  - You will need to cut this piece to size. Use the control panel as a template.
  - Use a razor knife to score the plexiglass **deeply**. Then use a pair of pliers to break away the extra plexiglass.
3. Now drill the holes in your panel that you have marked off for the *buttons, joystick and bolts*.

**Hint:** For best results, use a chassis or sheet metal punch for button holes.
4. Drill the same holes on your plexiglass panel protector. Once again use your panel as a template.

**Hint:** To avoid chipping while you are drilling the holes, place the plexiglass securely on a soft wood surface and use a plexiglass drill bit and hole cutter.
5. The holes are now all cut. Smooth them out on your panel and plexiglass with a fine toothed file.
6. Remove the original graphics overlay from the panel. Clean up the panel and install your **ROMSTAR** graphics.

**Make It Easier:** Peel the top half of the protective backing off of your graphics. Start from the center and smooth out your overlay. Make sure you have about an inch extra coming off the top. *No bubbles please*. Now peel off the bottom half and do the same as you did for the top.
7. Adhere the instruction and function labels.
8. Install the Plex Control Cover over your completed **new game** panel.

**Note:** Be sure to bolt the plexiglass securely to the panel.
9. Mount the joystick and the buttons to the panel and wire them up. (Use the existing Panel wiring if possible)

## Marquee Installation

Using the original marquee as a template, Center your **new game** marquee graphics and score the new marquee deeply to fit the cabinet. Break off the excess with pliers.

Note: when cutting marquee to size, check to make sure that you are cutting as little of the necessary art as possible (name, manufacturer, etc.)

**Be sure** the light behind the marquee works. Everything should **always work** on a new game.

Take your time ... Don't forget this is going to be a **new game**.

## Side Graphic Installation

1. Be sure sides of game are clean and free of old adhesive, dust, etc.
2. Mark position of decal with erasable pen or pencil (centered on upper half of cabinet).
3. Peel off top 1/4 of decal backing and apply to cabinet with a smoothing motion (use a soft rag). Continue peeling off backing and smoothing.
4. Remove any small bubbles with a pin or razor blade (pop them!)

## Finishing Touches

1. Check the game inside and out for any imperfections. Secure any loose wiring or fastening hardware.
2. Make sure the coin door is tight and the coin mechs are well adjusted. A game is no good to anybody if you can't get a coin into it.
3. Once again go over every step of this **new game** transformation in your mind. Be sure everything is correct and to your liking.
4. Power up the game.
  - A. Check all the coin switches. (Does the coin meter work?)
  - B. Play your **new game**.
    - Are all the player controls working?
    - Are the game sounds present?
    - Is the volume level proper?
    - Are the dip switches set properly?

Well, that's about it. Good Luck.

---

## Coin Meter Diagram

To attach a coin meter, use following diagram:

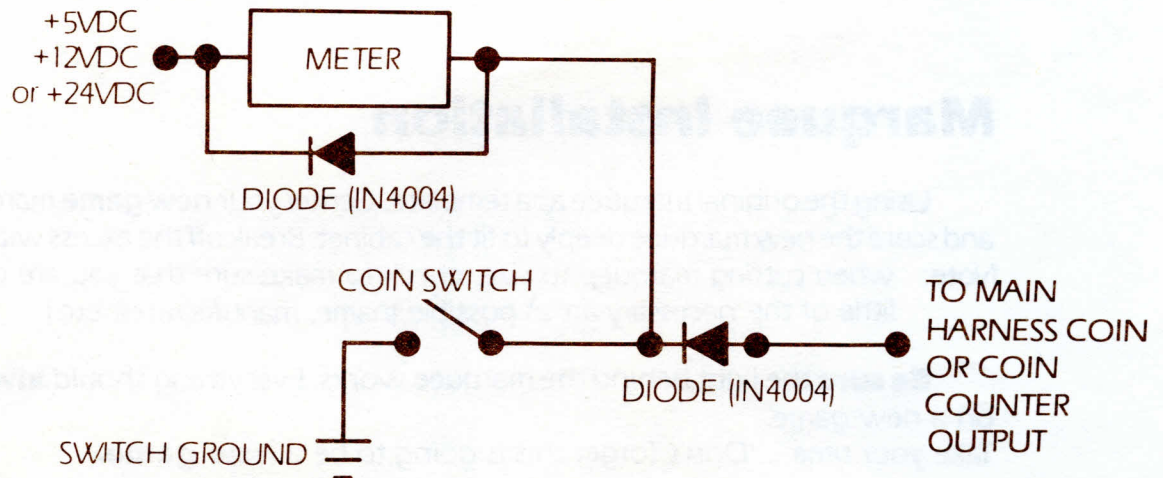

## Star Tech Tips

We are grateful to Star Tech Journal™ for allowing us to publish the following excerpts from their journal.

### 1. Monitor Sync

If your monitor does not have dual polarity positions for sync, you may use one of the following methods to get your game going.

**CURE 1:** Install a simple one I.C. Circuit on your logic board. This I.C. may be "piggy backed" on to another 7404 series chip for power by bending up all but the two power pins so that they are parallel to the top surface of the new I.C. and then connecting the power pins only to the existing chip. (See Fig. 1) Next connect the sync wires as shown in Fig. 2. (Note: Figure 2 shows a hookup for either **composite** or **separate** syncs.)

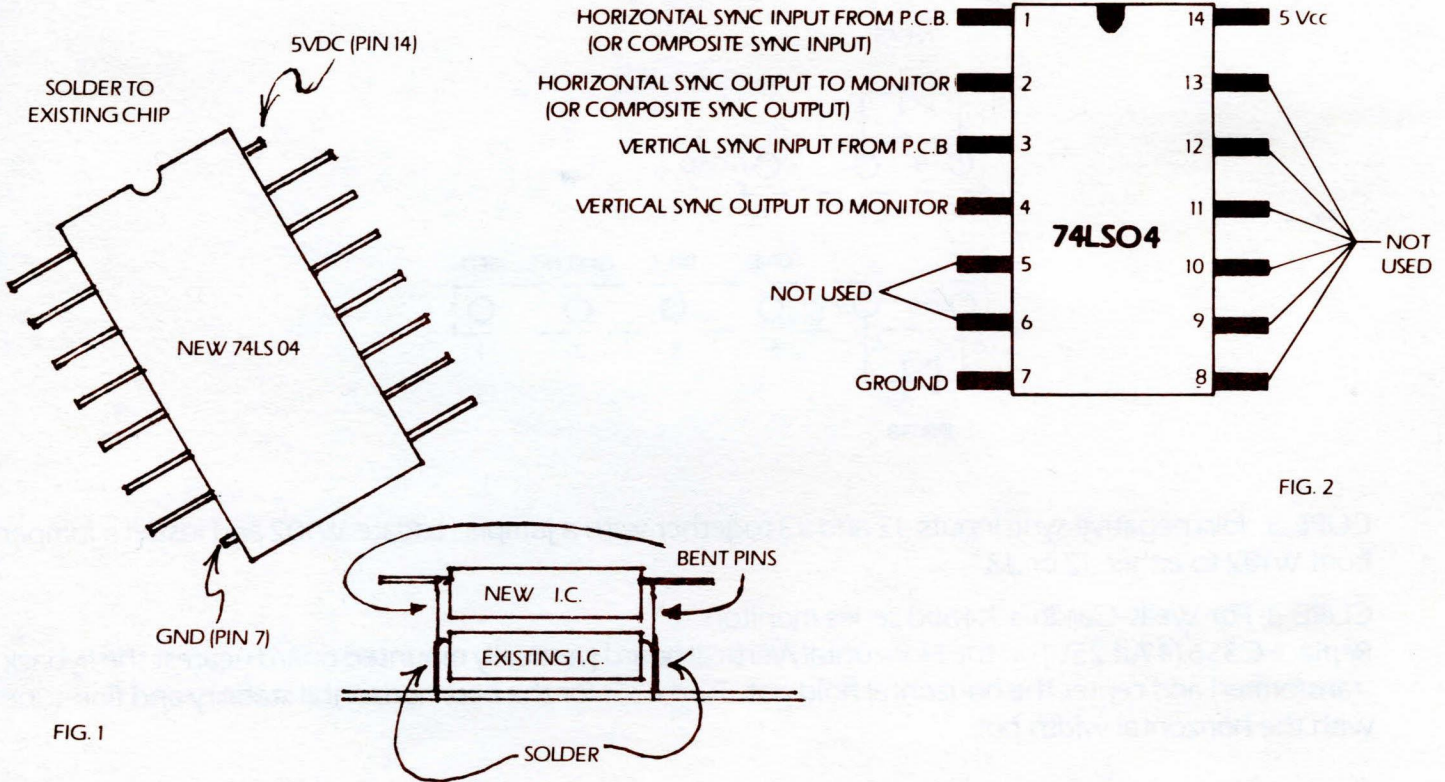

FIG. 2

FIG. 1

**CURE 2:** Used for Wells-Gardner Video-Sync boards with positive sync connections only. (Vertical mount board 85x140B.

Cut the traces on the solder side of the board between input pins 5 & 6 to the unbanded (anode) ends of diodes X201 & X202.

Add MPSA56 transistor as follows:

Collector to anode leads of diodes X201 & X202. Base to pins 5 & 6 of the video input connector.

Emitter to cathode (banded) lead of zener diode ZD201.

Insert a 1N4148 diode - cathode to the emitter of the MPSA56 and anode to the base. (See Fig. 3)

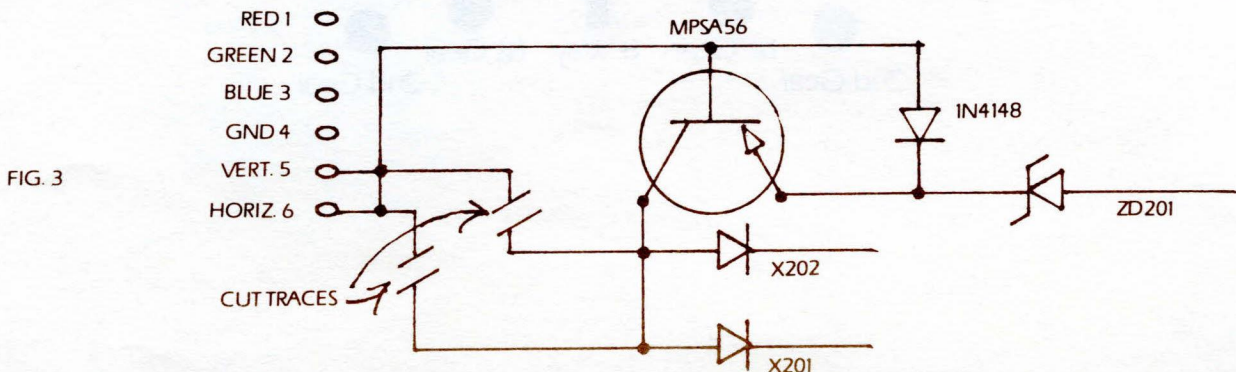

FIG. 3

## 2. Horizontal Tearing

**CAUSE:** The negative sync signal of most logic sets are slightly different than the GO7-CBO monitor negative sync inputs. The result of this mismatch is a horizontal "wave" or "curl".

**CURE 1:** On the monitor deflection board, replace C303 with a 10uf 25V radial lead capacitor with the positive lead towards the collector of X305. (CAUTION: be sure to check this step as the original cap is not polarized.) Then replace C501 with the cap removed from the C303 location.

**CURE 2:** Connect IN4148 fast-switching diodes across both the positive and negative sync inputs to the monitor. (See Fig. 4) NOTE: Both diodes must be installed or you will not have vertical stability.

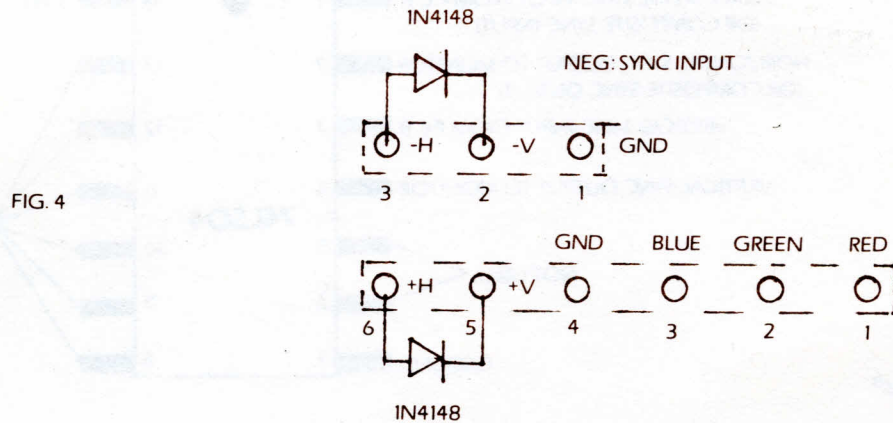

**CURE 3:** Join negative sync inputs J2 and J3 together with a jumper. Locate W102 and install a jumper from W102 to either J2 or J3.

**CURE 3:** For Wells-Gardner K4600 series monitors

Replace C356 (4.7uf 25V) on the Horizontal/vertical board (vertically mounted board nearest the flyback transformer) and center the horizontal hold pot. Turn L351 for the best horizontal stability and fine-tune with the horizontal width pot.

## Control Panel Positioning

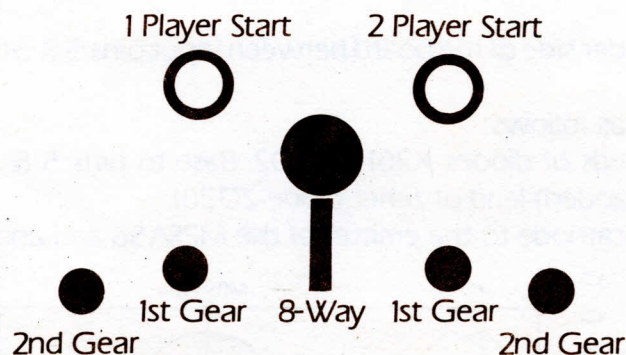

## DIP SW — F1 DREAM

### DIP SW A

ITEM	DESCRIPTION	1	2	3	4	5	6	7	8	
COIN 2	1 COIN / 1 CREDIT *	OFF	OFF	OFF						
	1 / 2	ON	OFF	OFF						
	1 / 3	OFF	ON	OFF						
	1 / 4	ON	ON	OFF						
	1 / 6	OFF	OFF	ON						
	2 / 2	ON	OFF	ON						
	3 / 1	OFF	ON	ON						
	4 / 1	ON	ON	ON						
COIN 1	1 COIN / 1 CREDIT *				OFF	OFF	OFF			
	1 / 2				ON	OFF	OFF			
	1 / 3				OFF	ON	OFF			
	1 / 4				ON	ON	OFF			
	1 / 6				OFF	OFF	ON			
	2 / 1				ON	OFF	ON			
	3 / 1				OFF	ON	ON			
	4 / 1				ON	ON	ON			
TEST MODE	NORMAL							OFF		
	TEST							ON		
SCREEN FLIP	NORMAL *									OFF
	FLIP									ON

### DIP SW B

ITEM	DESCRIPTION	1	2	3	4	5	6	7	8	
NOT USED	N/A *	OFF	OFF							
TYPE	TABLE			OFF						
	UP RIGHT			ON						
F1 POINT	12				OFF	OFF				
	16				ON	OFF				
	18				OFF	ON				
	20				ON	ON				
DIFFICULTY	NORMAL *						OFF			
	DIFFICULT						ON			
VERSION	JAPAN							ON		
	USA *							ON		
CONTINUE PLAY	ON									OFF
	OFF *									ON

### DIP SW POSITION

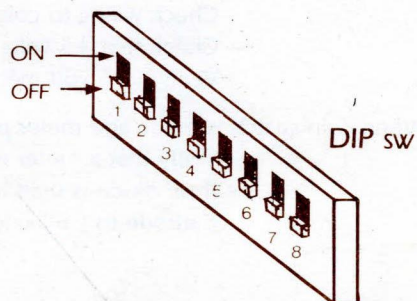
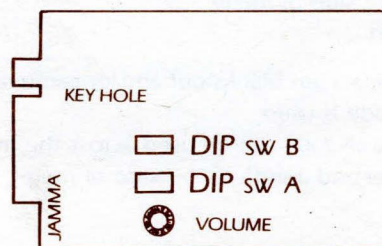

## CHECKPOINTS IN CASE OF DIFFICULTY

### PROBLEM / CAUSE-CURE

#### No Raster/No Video

- Check A.C. line cord
- Check line fuse
- Check monitor brightness
- Check power switch and/or interlock switch
- Check all solder connections on line filter and transformer
- Check for proper orientation of the PCB connector

#### Raster/No Video

- Check all PCB to monitor connections
- Check power supply voltage on PCB

#### No Video/Game sounds can be heard

- Check monitor brightness
- Check all PCB to monitor connections

#### Wrong colors

- Monitor needs degaussing
- Check for proper wiring between PCB and monitor
- Check monitor adjustment and adjust if necessary

#### Wavy picture

- Check monitor ground is properly connected to monitor
- Be certain sync inputs are properly connected to monitor
- Check horizontal hold adjustment

#### Horizontal/Vertical Roll

- Check horizontal and/or vertical hold adjustments
- Check for proper wiring of sync from PCB to monitor

#### No sound

- Check for - 5 volts on edge connector of PCB
- Check volume control potentiometer adjustment
- Check for +12 volts on edge connector of PCB
- Check wiring from PCB to speaker
- Check speaker for low resistance between the "+" and "-" tabs

#### Bad sound

- Check wiring to speaker for bad solder connections
- Check sound with another speaker

#### No switch input

- Check ground connection to switch/es
- Check wiring between PCB and switch/es for proper connection
- Check switch/es with an ohmmeter to verify proper operation

#### Switch operates incorrect function

- Check wiring between PCB and switches for proper orientation
- Check wiring for shorts between switch inputs

#### No coin meter

- Check wiring to coin meter
- Check that +5 volts is on "+" side of meter
- Verify a +5 volt meter is used

#### When coin switch is made and meter pulses, the screen blanks out and/or game resets

- Verify that a meter with a diode is used
- If no diode is built in meter a IN4004 can be used across the meter. Cathode to "+" side of meter and anode to "-" side of meter



Black JAMMA HARNESS TA.1

Wire Color	Solder Side	Parts Side		Wire Color
		1	2	
Black	Ground	Ground	Ground	Black
Black	Ground	Ground	Ground	Black
Red	+5VDC	+5VDC	+5VDC	Red
Red	+5VDC	+5VDC	+5VDC	Red
White	N/A	N/A	N/A	White
Yellow	+12VDC	+12VDC	+12VDC	Yellow
	Post	Post	Post	
Brown	Coin Counter 2	Coin Counter 1	Coin Counter 1	Brown
Red	Coin Lockout	Coin Lockout	Coin Lockout	Red
Black	Speaker (-)	Speaker (+)	Speaker (+)	White
Blue	N/A	N/A	N/A	Blue
Green	Video Green	Video Red	Video Red	Red
Gray	Video Sync (comp/Neg)	Video Blue	Video Blue	Blue
Red	Service Switch	Video Ground	Video Ground	Black
Brown	N/A	N/A	N/A	Brown
White	Coin 2	Coin 1	Coin 1	White
Gray	2P Start	IP Start	IP Start	Gray
Violet	2P Up	IP Up	IP Up	Violet
Blue	2P Down	IP Down	IP Down	Blue
Green	2P Left	IP Left	IP Left	Green
Yellow	2P Right	IP Right	IP Right	Yellow
Orange	2P 1st Gear	IP 1st Gear	IP 1st Gear	Orange
Red	2P 2nd Gear	IP 2nd Gear	IP 2nd Gear	Red
Brown	N/A	N/A	N/A	Brown
Blue	N/A	N/A	N/A	Blue
Blue	N/A	N/A	N/A	Blue
Black	Ground	Ground	Ground	Black
Black	Ground	Ground	Ground	Black

\* 2P Controls Are Used On Table Top Games Only.

BLACK JAMMA HARNESS DA. 1

Wire Color	Solder Side	Parts Side		Wire Color
		A	1	
Black	Ground	Ground	Ground	Black
Black	Ground	Ground	Ground	Black
Red	+5VDC	+5VDC	+5VDC	Red
Red	+5VDC	+5VDC	+5VDC	Red
White	-5VDC	-5VDC	-5VDC	White
Yellow	+12VDC	+12VDC	+12VDC	Yellow
	Post	Post	Post	
Brn/Wht	Coin Counter 2	Coin Counter 1	Coin Counter 1	Brn/Wht
Red/Blk	Coin Lockout	Coin Lockout	Coin Lockout	Red/Blk
Wht/Blk	Speaker (-)	Speaker (+)	Speaker (+)	White
Green	Video Green	Video Red	Video Red	Red
Gray	Video Sync (comp/Neg)	Video Blue	Video Blue	Blue
Red/Blk	Service Switch	Video Ground	Video Ground	Black
	Tilt Switch	Test Switch	Test Switch	Brown
Wht/Blk	Coin 2	Coin 1	Coin 1	White
Wht/Grn	2P Start	IP Start	IP Start	Gray
Wht/Vio	2P Up	IP Up	IP Up	Violet
Wht/Blu	2P Down	IP Down	IP Down	Blue
Wht/Grn	2P Left	IP Left	IP Left	Green
Wht/Yel	2P Right	IP Right	IP Right	Yellow
Wht/Ora	2P	IP	IP	Orange
Wht/Red	2P	IP	IP	Red
Wht/Brn				Brown
Grn/Wht				Blu/Wht
Yel/Wht				Red/Wht
Black	Ground	Ground	Ground	Black
Black	Ground	Ground	Ground	Black

Wire color /Stripe color

Note: Please refer to manual harness pinout for pins 22, 23, Z, a

BLUE JAMMA HARNESS CA.1

F1 DREAM

Wire Color	Solder Side		Parts Side		Wire Color
Black	Ground	A	1	Ground	Black
Black	Ground	B	2	Ground	Black
Red	+5VDC	C	3	+5VDC	Red
Red	+5VDC	D	4	+5VDC	Red
	N/A	E	5	N/A	
Yellow	+12VDC	F	6	+12VDC	Yellow
	Post	H	7	Post	
Red	Coin Counter 2	J	8	Coin Counter 1	Violet
	Coin Lockout	K	9	Coin Lockout	
Black	Speaker (-)	L	10	Speaker (+)	Gray
	N/A	M	11	N/A	
Green	Video Green	N	12	Video Red	Red
White	Video Sync <small>(Comp/Neg)</small>	P	13	Video Blue	Blue
Pink	Service Switch	R	14	Video Ground	Black
Yellow	Tilt Switch	S	15	Test Switch	Blue
Orange	Coin 2	T	16	Coin 1	Tan
Gray	2P Start	U	17	1P Start	Brown
Green	2P Up	V	18	1P Up	Green
Blue	2P Down	W	19	1P Down	Blue
Violet	2P Left	X	20	1P Left	Violet
Yellow	2P Right	Y	21	1P Right	Yellow
Red	2P 1st Gear	Z	22	1P 1st Gear	Red
Orange	2P 2nd Gear	a	23	1P 2nd Gear	Orange
	N/A	b	24	N/A	
	N/A	c	25	N/A	
	N/A	d	26	N/A	
Black	Ground	e	27	Ground	Black
Black	Ground	f	28	Ground	Black

\* 2P Controls Are Used On Table Top Games Only.



