

AMSTRAD

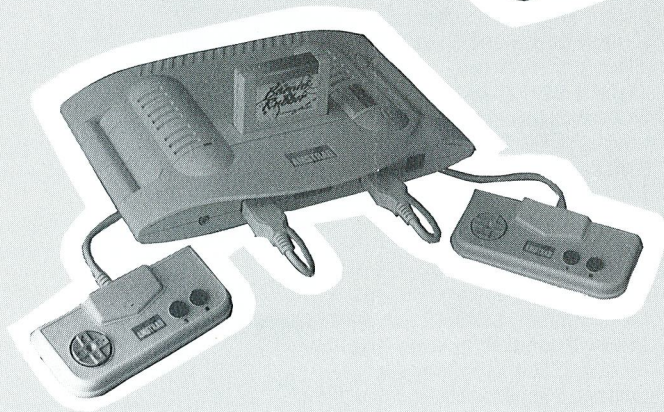

464 PLUS HOME COMPUTER
6128 PLUS HOME COMPUTER
GX4000 GAMES CONSOLE
MM 12 MONOCHROME MONITOR
CM 14 COLOUR MONITOR

SERVICE MANUAL

CONTENTS

	Page
Safety Tests	2
464 PLUS SECTION	3
Electrical Adjustments	4
Main/Cassette/Hold/LED P.C.B. (Top View)	5
Main/Cassette/Hold/LED P.C.B. (Bottom View)	6
Tape P.C.B.	6
Gate Array/Output Interface Schematic Diagram	7
CPU/Connection Interface Schematic Diagram	8
Video Conversion/Memory Schematic Diagram	9
Cassette Interface Schematic Diagram	10
Key Matrix (Applies to 464 & 6128)	11
Mechanical Exploded View & Parts List	12
Deck Exploded View	13
Electrical Parts List	14
6128 PLUS SECTION	15
Electrical Adjustment	15
Main/Cassette Hold/LED P.C.B. (Top View)	16
Main/Cassette Hold/LED P.C.B. (Bottom View)	17
Gate Array/Output Interface Schematic Diagram	18
CPU/Connection Interface Schematic Diagram	19
Video Conversion/Memory Schematic Diagram	20
Mechanical Exploded View & Parts List	21
Electrical Parts List	22
GX4000 SECTION	23
Electrical Adjustment	23
Main P.C.B. (Top View)	24
Main P.C.B. (Bottom View)	25
Gate Array/Output Interface Schematic Diagram	26
CPU/Connection Interface Schematic Diagram	27
Video Conversion/Memory Schematic Diagram	28
Power Regulator Schematic Diagram	29
RGB Convertor Schematic Diagram	30
Cabinet Exploded View & Parts List	31
Main P.C.B. (FRANCE) (Top View)	32
Main P.C.B. (FRANCE) (Bottom View)	33
Power Regulator Schematic Diagram (FRANCE)	34
Output Interface Schematic Diagram (FRANCE)	35
Electrical Parts List	36
MM-12 SECTION	37
Electrical Adjustments	37
Monitor/CRT P.C.B. Component Layout	38
Cabinet & Parts List	39
Monitor/CRT Schematic Diagram	40, 41
Electrical Parts List	42
CM-14 SECTION	43
Electrical Adjustments	44 - 46
Electrical Parts List	47, 48
Monitor/CRT P.C.B. (Component Layout)	49
Power/Sound Schematic Diagram	50
Monitor Schematic Diagram	51
Cabinet Exploded View & Parts List	52

NOTE TO ENGINEERS

Please Note: That RP11 Diagnostic Rom Cartridge is available to diagnose fault conditions on this range of home computers. Full instructions and analysis is made in the user instruction manual.

SAFETY TEST

All monitors are tested to the following specifications.

1. **Flash Test:** Test at 1.5kV RMS / 3 sec between the live and neutral poles of the mains lead and all accessible metal points on the exterior of the set.
2. **Insulation Resistance Test:** Test at 1.5kV RMS / 3 sec between the live and neutral poles of the mains lead and all accessible metal points on the exterior of the set to show a resistance greater than 4Mohms.
3. **Earth Continuity Test:** The resistance of the mains lead shall not exceed 0.5ohms.

PLEASE NOTE: When any work is completed on this unit, correct safety tests must be carried out to ensure continued electrical safety.

PLEASE NOTE: All parts shown with the part number prefix  are Safety Items and must be replaced with similar items having an identical safety specification.

All those items may be purchased direct from AMSTRAD plc.

In keeping with our policy of continually improving our service, and the technical quality of our products, we reserve the right to change component types, manufacturers, sources of supply or technical specification at any time.

AMSTRAD PLC

BRENTWOOD HOUSE, 169 KINGS ROAD, BRENTWOOD, ESSEX CM14 4EF.

464 PLUS TECHNICAL SPECIFICATION

LSI CHIPS

Z80A processor running at 4MHz.
 64K of RAM (over 41K available when using BASIC).
 128K byte ROM cartridge containing BASIC firmware and "Burnin' Rubber" game.
 GI AY-3-8912 3 voice, 8 octave sound generator chip.
 Application Specific Integrated Circuit (ASIC) containing 18,000 gates.
 Includes emulation of 6845 video controller and 8255 parallel peripheral interface. Chip also contains 16,000 bits of storage for sprite data.

DISPLAY SPECIFICATION (BASIC)

Display Mode	Mode 1	Mode 2	Mode 3
No. of colours	4 from 27	2 from 27	16 from 27
Vertical dots	200	200	200
Horiz. dots	320	640	160
Characters	40 × 25	80 × 25	20 × 25

DISPLAY SPECIFICATION (CARTRIDGE GAMES)

16 mode independent sprites are available in 16 different colours from those used to draw the main screen.
 Both sprite colours and main screen colours may now be chosen from a palette of 4096. (16 levels of Red, Green and Blue).

Display Mode	Mode 1	Mode 2	Mode 3
No. of colours	4 from 4096	2 from 4096	16 from 4096
No. Sprites	16	16	16
Sprite colours	16 from 4096	16 from 4096	16 from 4096

EXTRA FEATURES (CARTRIDGE GAMES)

Analogue joystick support.
 Soft Scroll allows pixel-wise movement in vertical and horizontal for fast action games.
 Split Screen allows two separate areas to be displayed at once alleviating the need to re-draw score bars etc.
 DMA driven sound allows tunes to play without processor intervention.
 Raster Interrupt allows games to change mode and colours at fixed points on the screen.

KEYBOARD

74 keys – QWERTY style, numeric cluster, cursor and copy cursor, large enter, shift, caps lock, tab, escape, delete, clear, control.

DATACORDER

Write speed software selectable – 1K baud or 2K baud, read speed automatically established by software. Write protect interlock. Motor on/off controlled by software.

ADD-ON ABILITY

8 bit Centronics compatible printer.
 1 or 2 digital joysticks or paddles.
 IBM Standard analogue joystick. (Some cartridge games).
 Light gun.
 Various peripherals.
 ROM cartridge up to 512K byte capacity.

EXTERNAL SOCKETS

3.5 mm stereo jack plug for connection to external amplifier.
 2 × 9 Pin D-type digital paddle/joystick connectors.
 15 Pin D-type analogue joystick connector (IBM Standard).
 RJ11 "telephone" jack for connection of light gun.
 25 way D-type connector for 8 bit Centronics interface.
 50 way Amphenol style connector with full Z80 bus for addition of other devices (e.g. serial interface).
 8 Pin DIN socket for RGB, sync, Luminance and stereo sound connection to monitor.
 5 mm socket for connection of 5V power supply for monitor.

DIMENSIONS mm (approx.)

	Width	Height	Depth
Computer	398	46	297
MM12 mono motor	329	308	307
CM14 colour monitor	377	348	360
Paddle controller	124	22	56

POWER SUPPLY

MM12 Monitor: 240V AC (UK), 220V AC (Europe) 50Hz.
 CM14 Monitor: 220-240V AC 50Hz.

ELECTRICAL ADJUSTMENTS

AZIMUTH

1. Connect the probe of oscilloscope to jumper line ④.
2. Insert the test tape (MTI-113, 6.34KHz) for adjustment into the deck.
3. Press the PLAY button to operate the tape.
4. Adjust the screw ① to maximize the waveform as shown below.

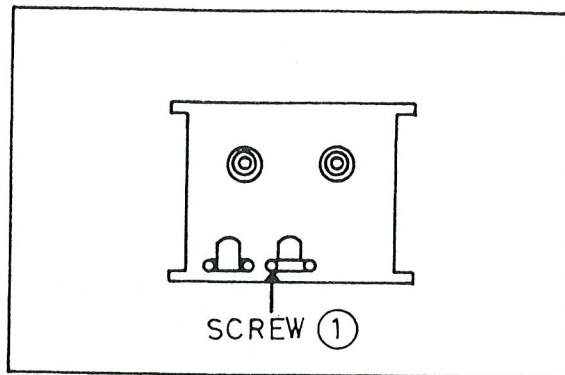

LUMI. SIGNAL OUTPUT LEVEL

1. Connect the oscilloscope to 3 pin of J102.
2. Adjust VR101 so that the signal becomes 1.65V as shown in Fig. 1.

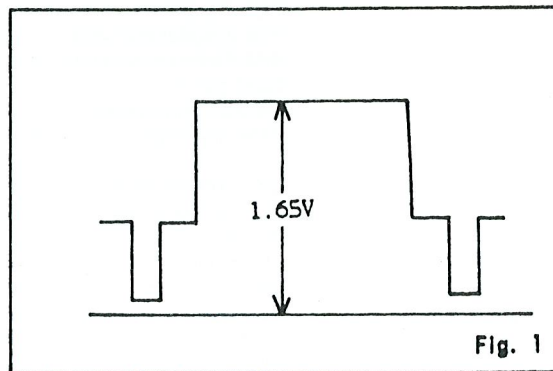

MAJOR COMPONENTS LOCATION GUIDE

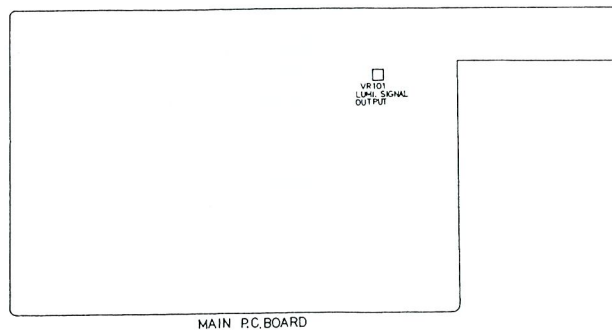

MAIN P.C. BOARD

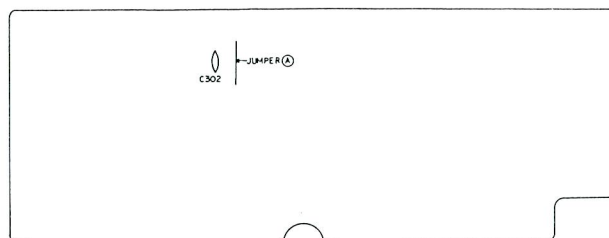

TAPE P.C. BOARD

MAIN/CASSETTE HOLD/LED

TOP

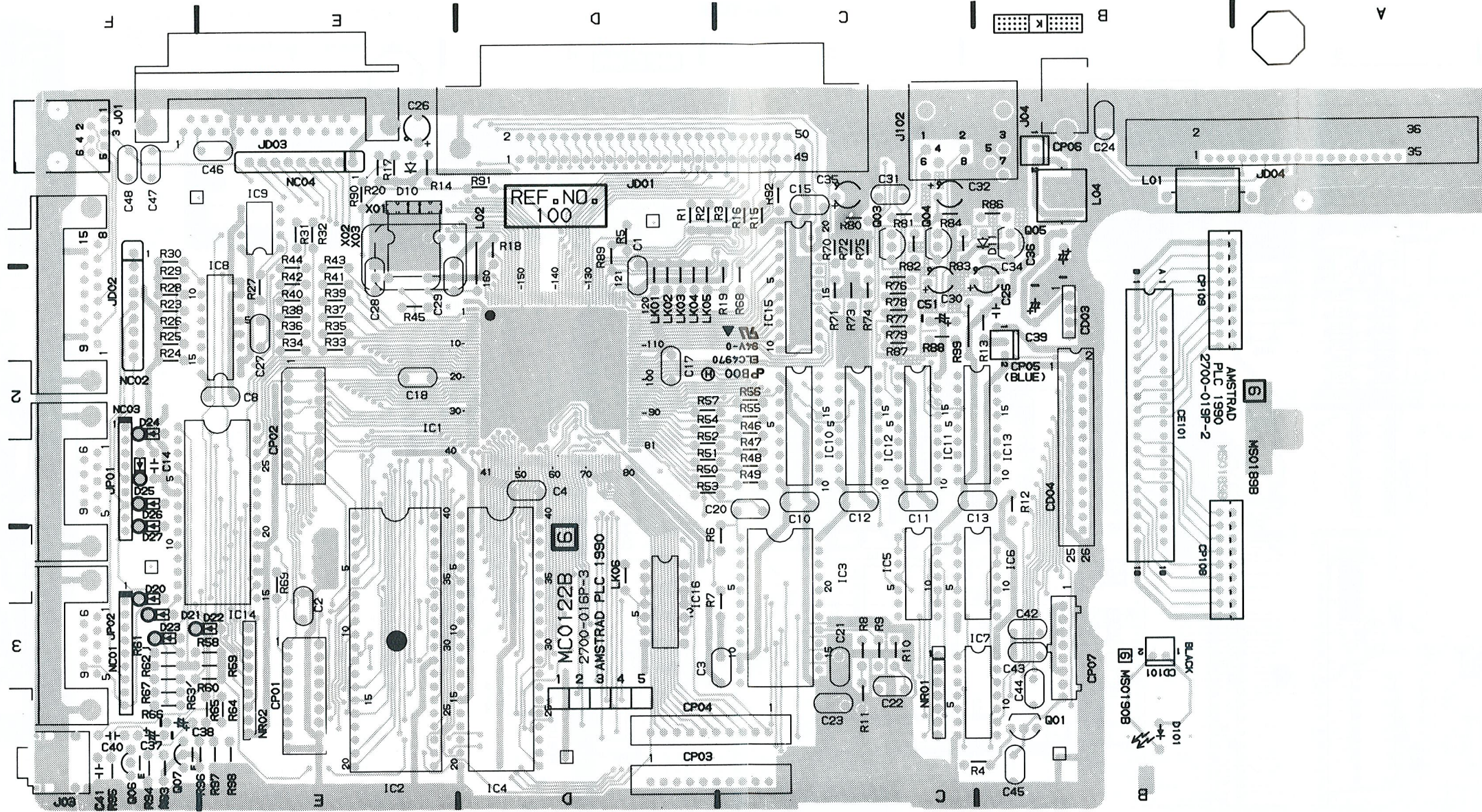

MAIN/CASSETTE HOLD/LED

TAPE

BOTTOM

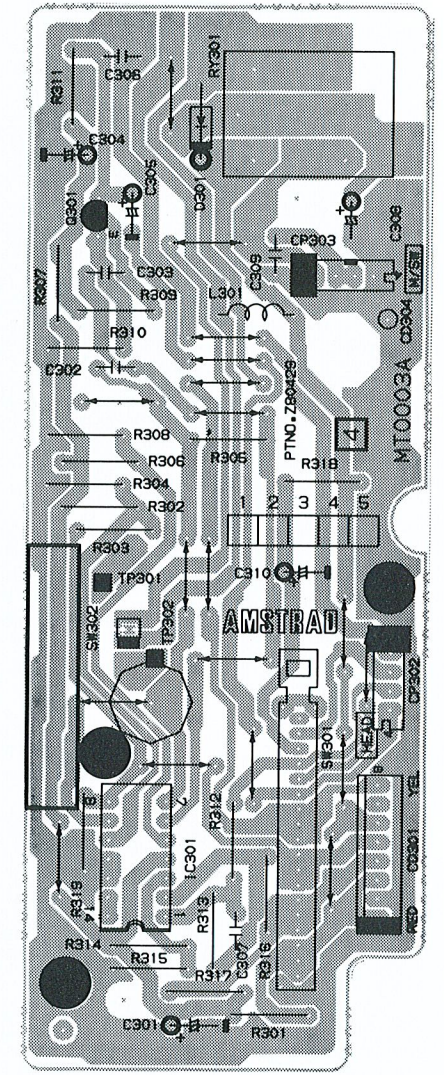
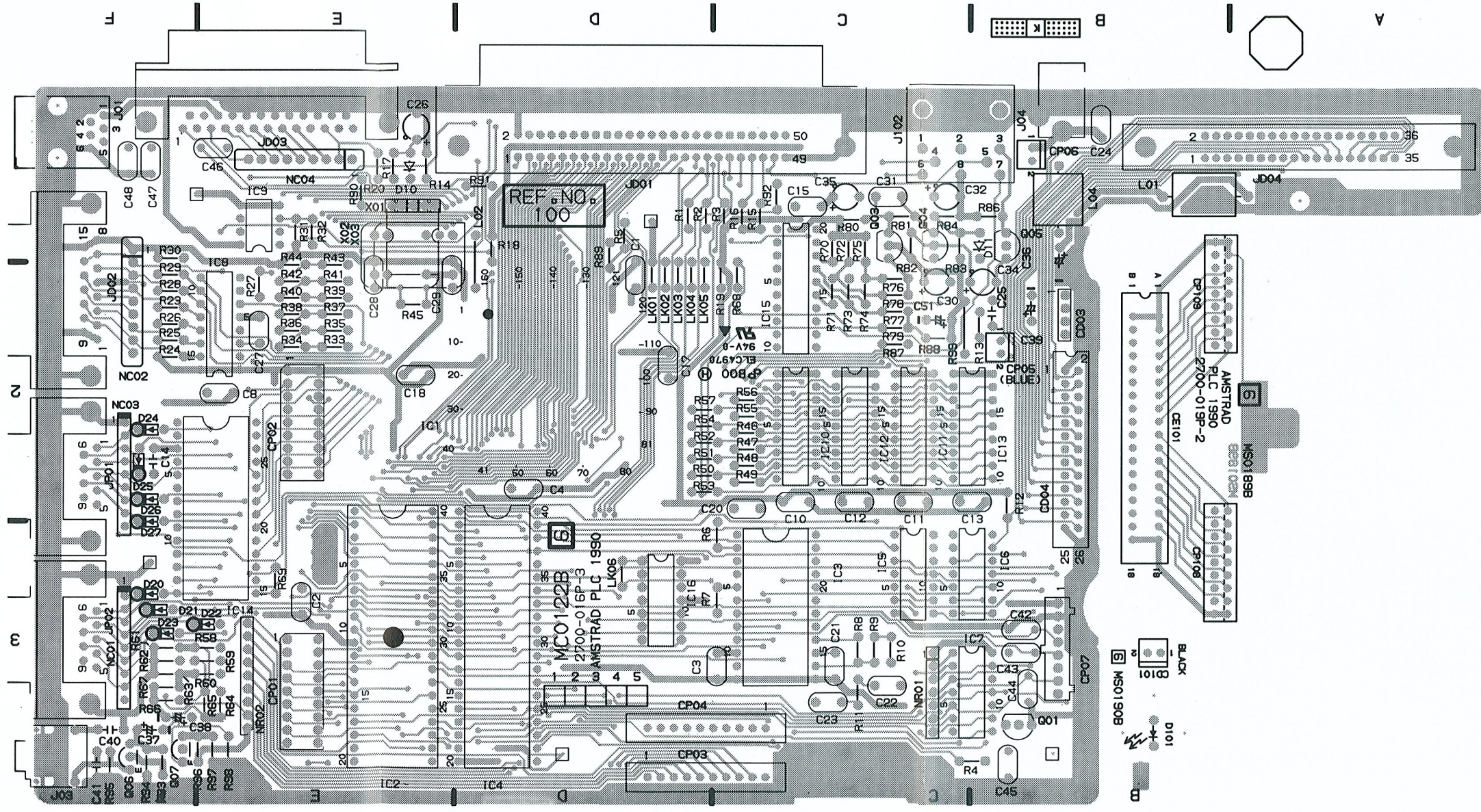

GATE ARRAY / OUTPUT INTERFACE SCHEMATIC DIAGRAM

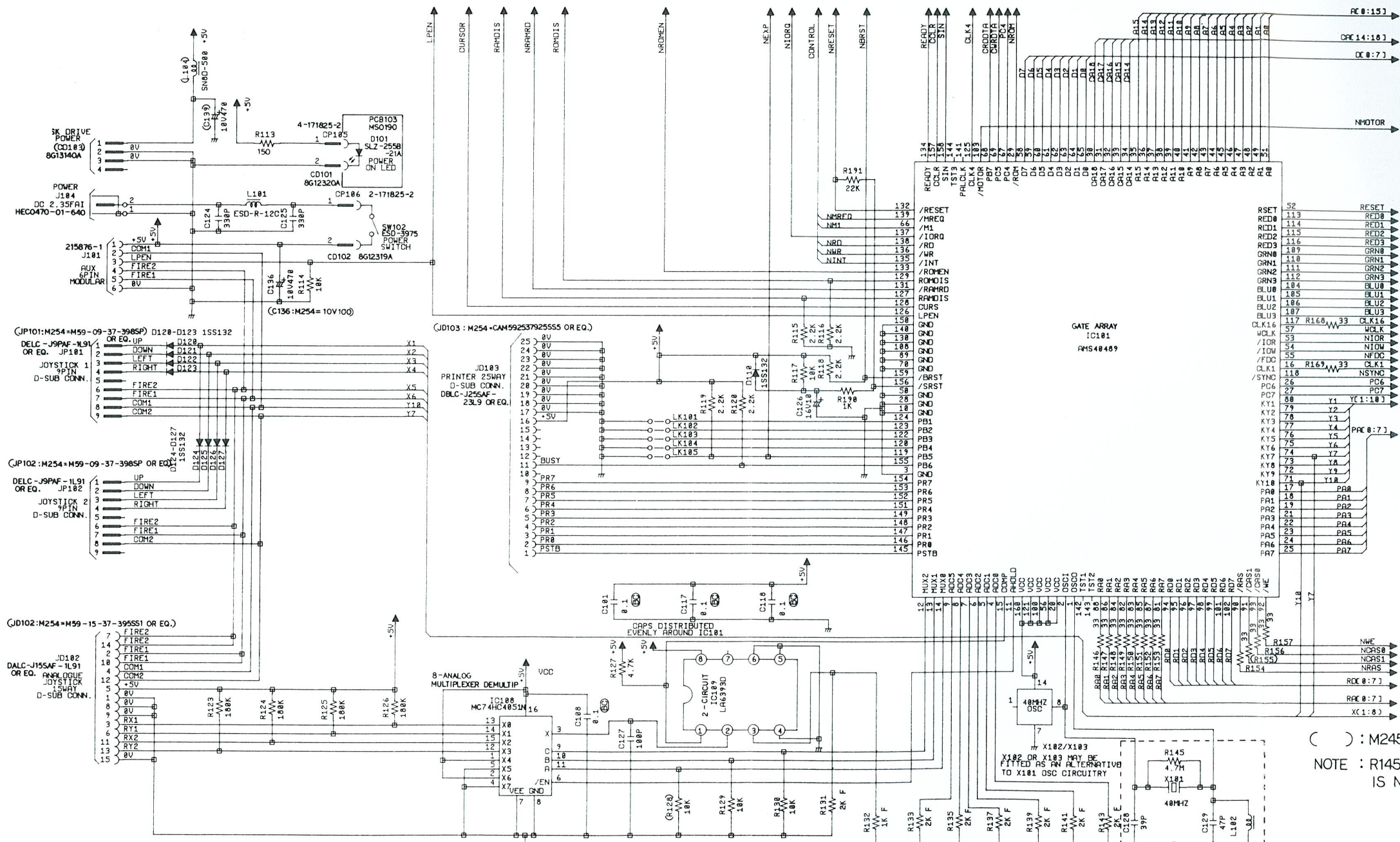

NOTE: THIS SCHEMATIC DIAGRAM IS THE LATEST AT THE TIME OF PRINTING AND SUBJECT TO CHANGE WITHOUT NOTICE.

NOTE: F, G, H, I, AND J MARKED AROUND THE PARTS IN THE SCHEMATIC DIAGRAM INDICATES THE FOLLOWING ERROR RATE.
F: ±1%, G: ±2%, H: ±3%, I: ±4%, J: ±5%

FIT R128 FOR 128K DRAM
FIT R129 FOR DISC VERS
FIT R130 FOR 8-BIT PRINTER

() : M245 ONLY
NOTE : R145, X101, C128, C129, L102 IS NOT USE

CPU / CONNECTION INTERFACE SCHEMATIC DIAGRAM

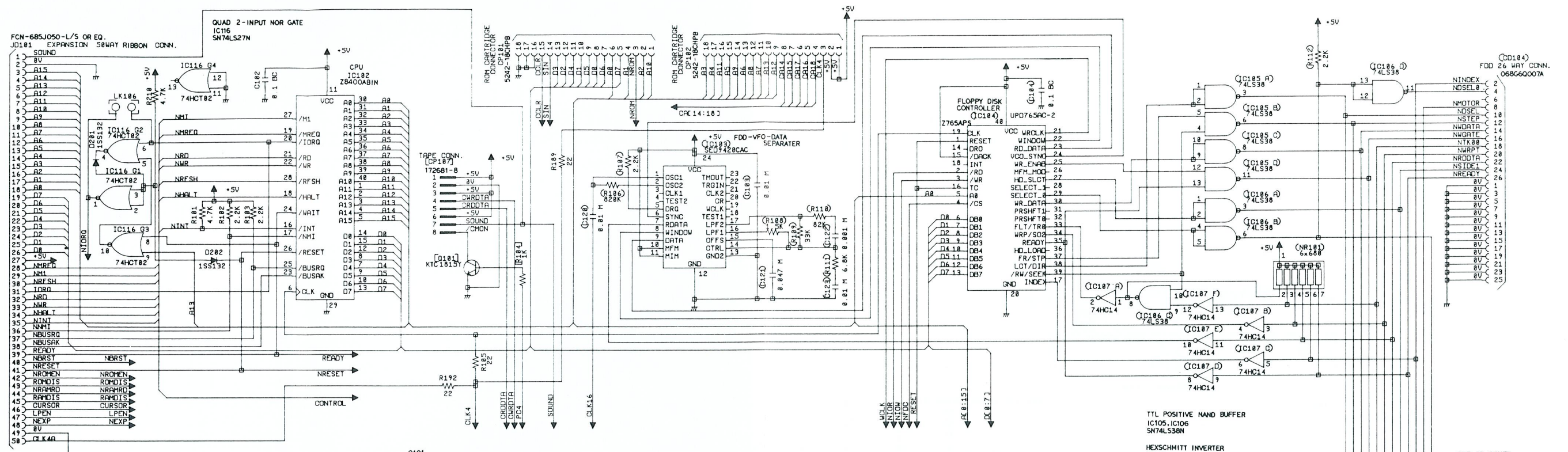

Q101 SWITCHING THE DECK MOTOR ON AND OFF WHEN PLAYING BACK OR READING.

TTL POSITIVE NAND BUFFER
IC105, IC106
SN74LS38N

HEXSCHMITT INVERTER
IC107
MC74HC14AN

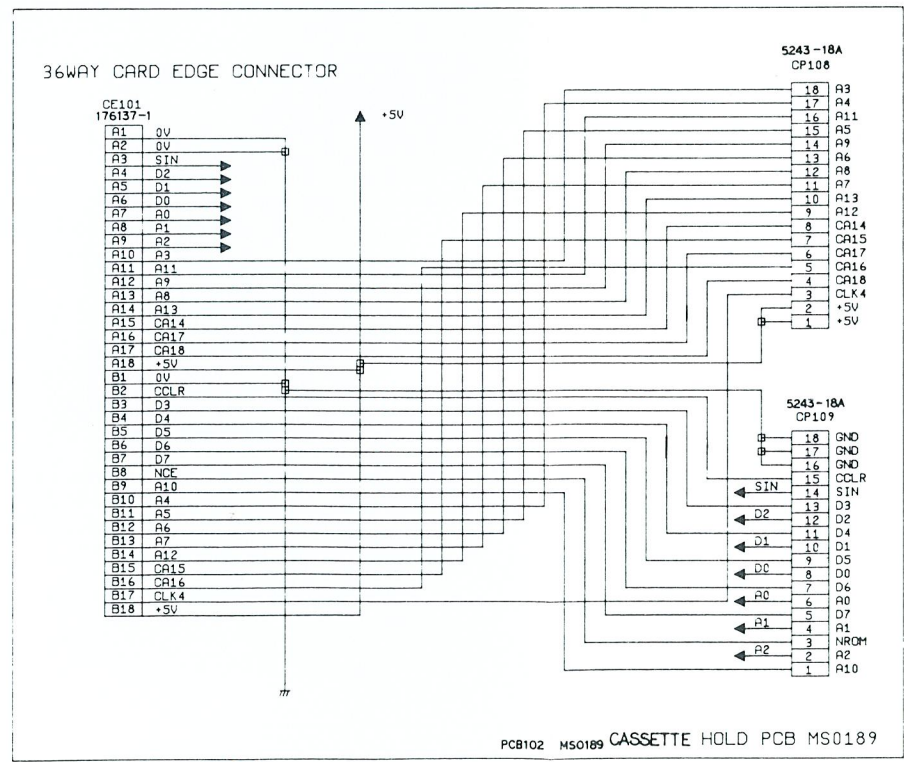

() : M254 ONLY
[] : M253 ONLY

PCB102 MS0189 CASSETTE HOLD PCB MS0189

NOTE: THIS SCHEMATIC DIAGRAM IS THE LATEST AT THE TIME OF PRINTING AND SUBJECT TO CHANGE WITHOUT NOTICE.

VIDEO CONVERSION / MEMORY SCHEMATIC DIAGRAM

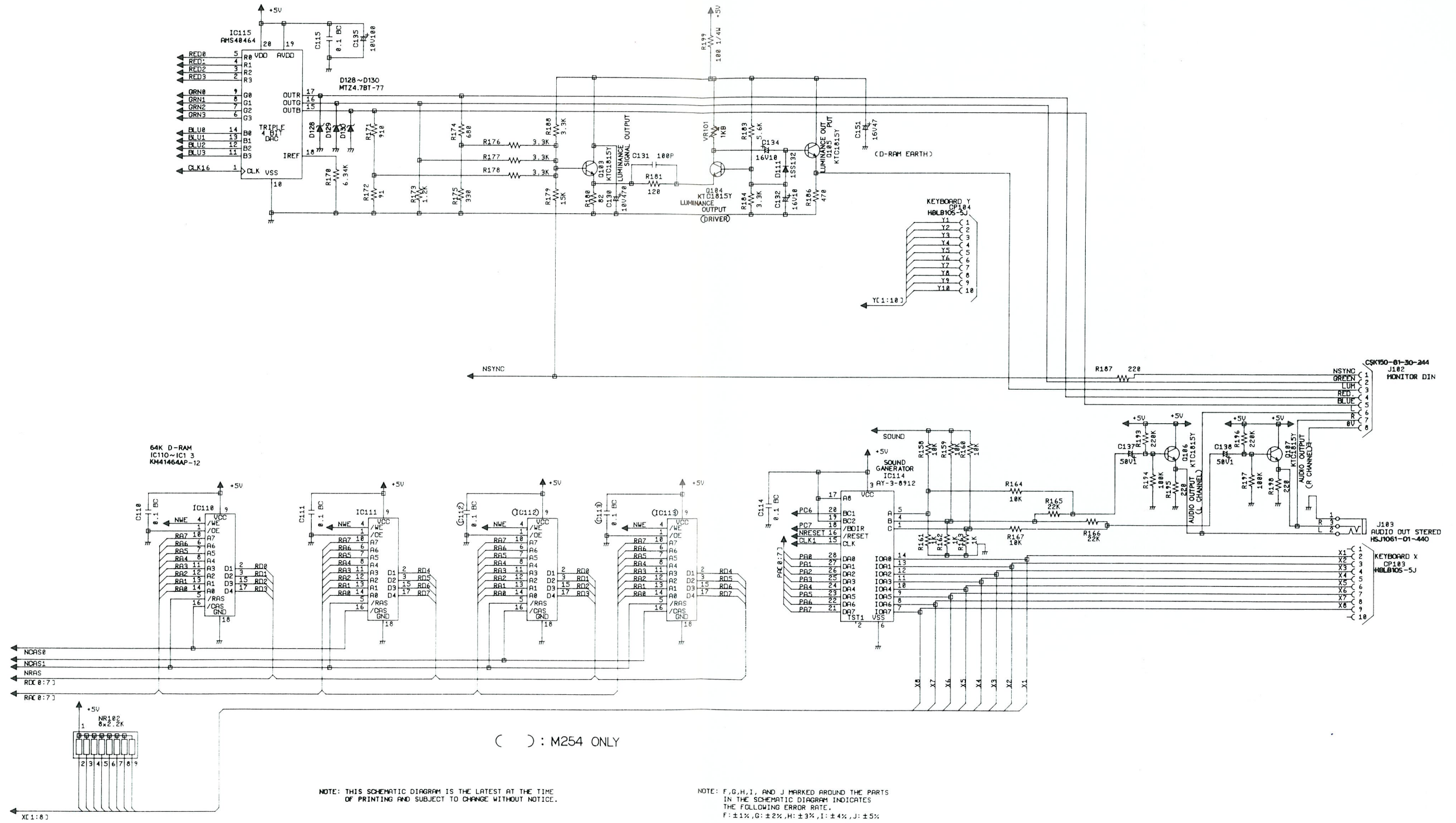

SCHEMATIC DIAGRAM CASSETTE INTERFACE

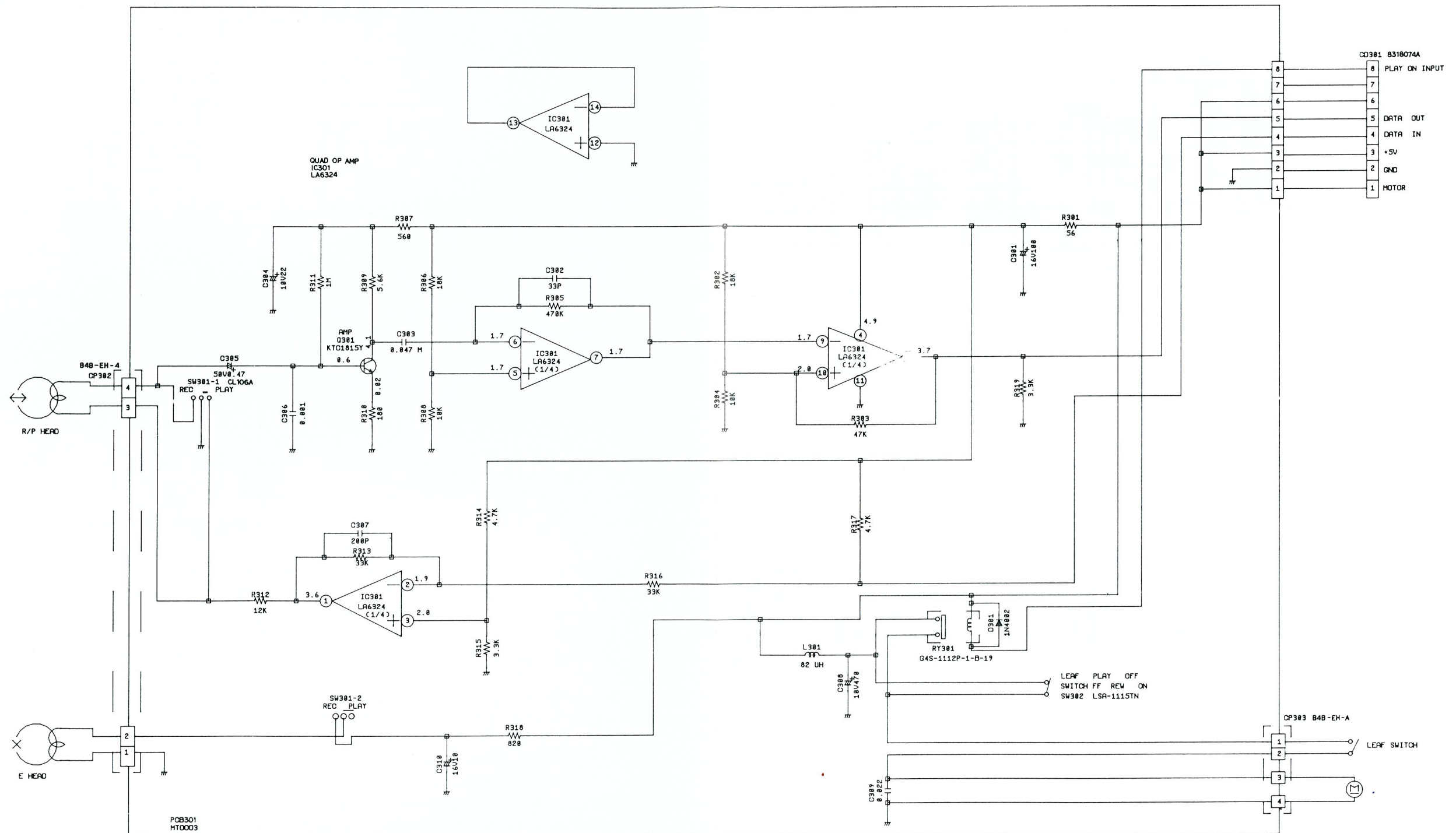

NOTE: THIS SCHEMATIC DIAGRAM IS THE LATEST AT THE TIME
OF PRINTING AND SUBJECT TO CHANGE WITHOUT NOTICE.

KEY MATRIX (Applies to 464 & 6128)

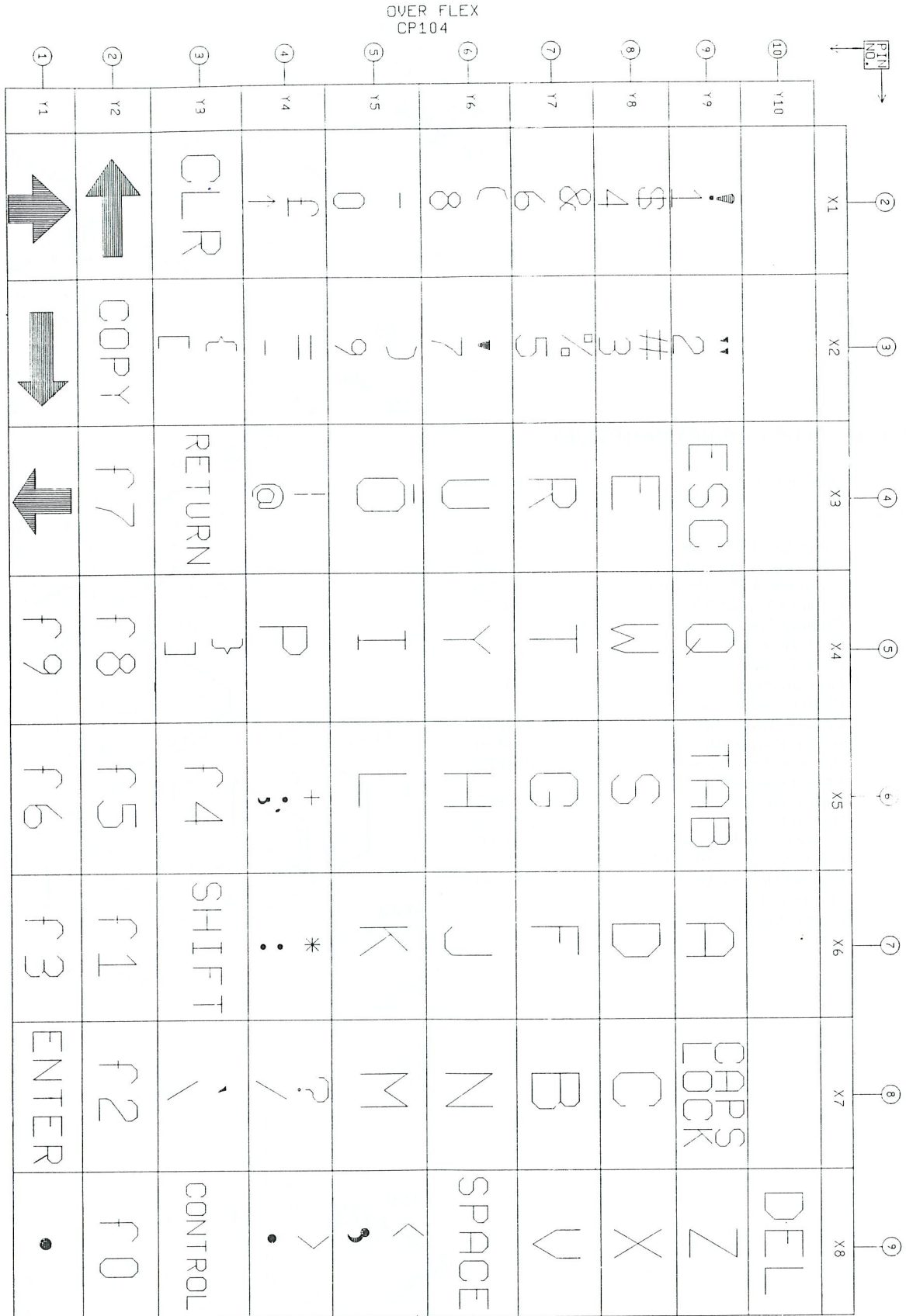

UNDER FLEX
CP103

NOTE: THIS SCHEMATIC DIAGRAM IS THE LATEST AT THE TIME OF PRINTING AND SUBJECT TO CHANGE WITHOUT NOTICE.

SW101 ESU44LN027AA

MECHANICAL EXPLODED VIEW

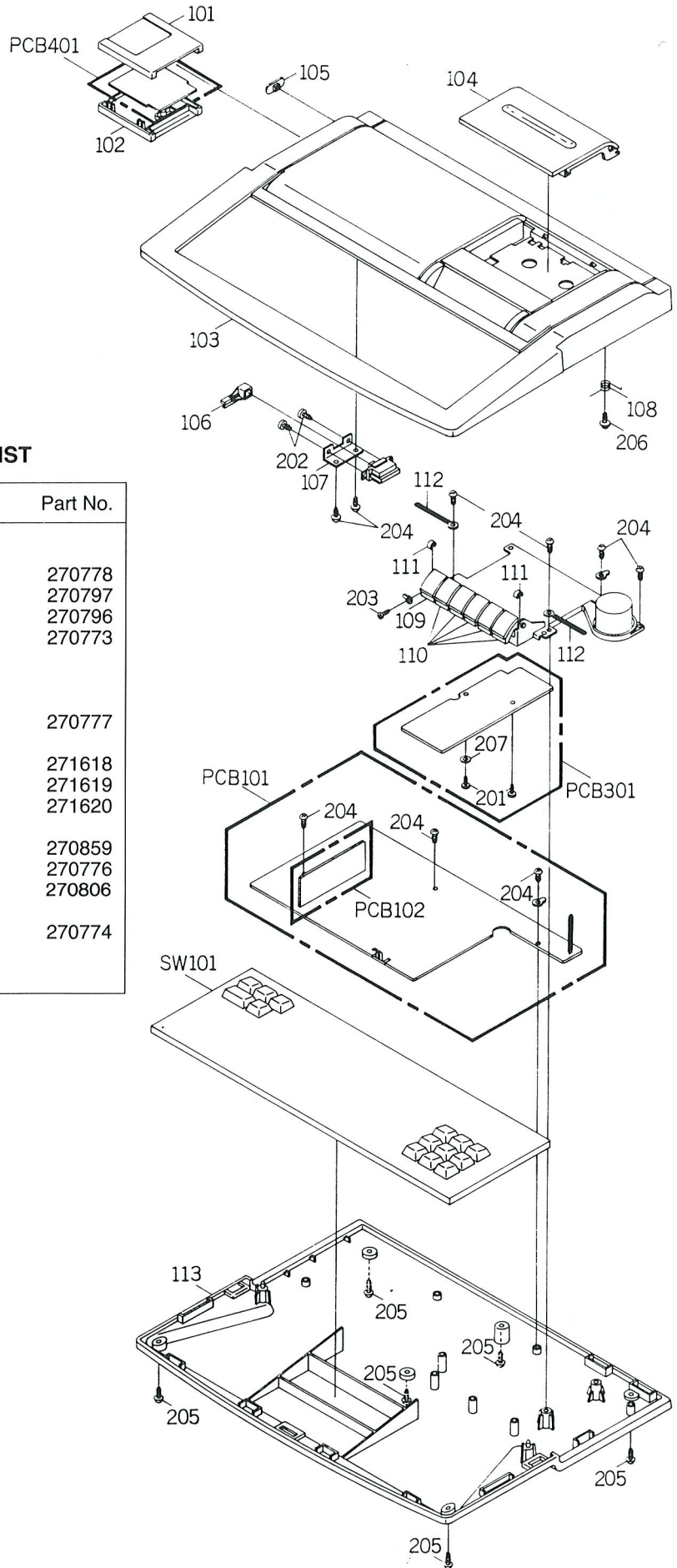

CPC 464 PLUS CABINET PARTS LIST

Ref. No.	Description	Part No.
Cabinet Parts		
101	Cartridge ASSY (UK)	270778
101	Cartridge ASSY (Spain)	270797
101	Cartridge ASSY (France)	270796
103	Cabinet Top ASSY	270773
	Cabinet Top	
	Plate Brand	
	Plate Reflection	
104	Lid Cassette	270777
	Plate Cassette Lid	
105	Button Power (A)	271618
106	Button Power (B)	271619
107	Bracket Power Switch	271620
108	Spring Cassette Lid	
109	Button Deck (REC)	270859
110	Button Deck	270776
111	Spacer Button Deck	270806
112	Cord Clamp No PEC-034-0	
113	Cabinet Bottom Assy	270774
	Leg Rubber	
	Sheet Rating	

DECK EXPLODED VIEW

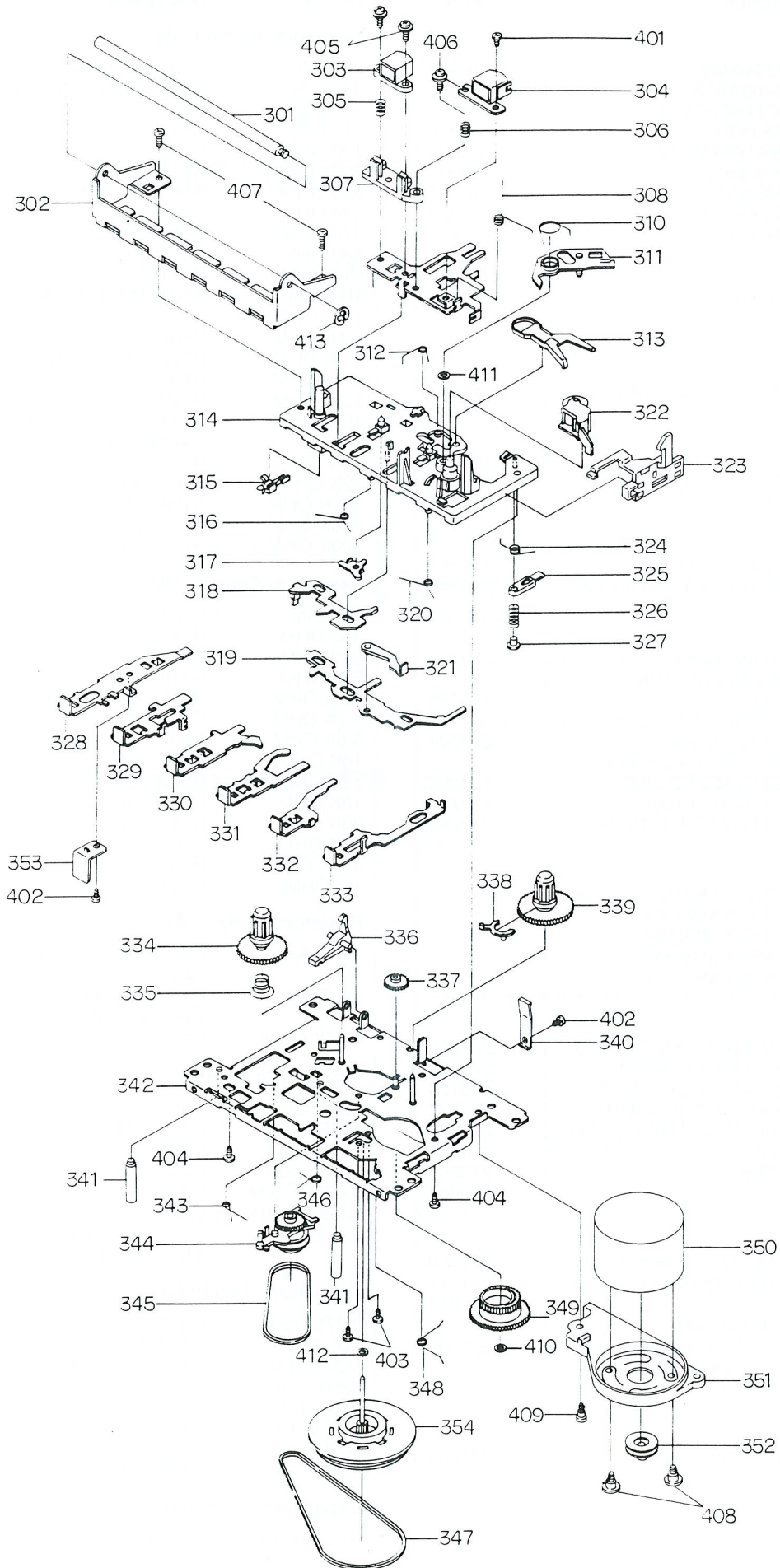

For parts list please refer to miscellaneous section.

464 PLUS ELECTRICAL PARTS LIST

Ref. No.	Description	Part No.
IC's		
IC101	IC AMS40489	40489
IC102	IC Z8400AB1N	40080
IC108	IC MC74HC4051N	270752
IC109	IC LA6393D	270997
IC110, 111	IC KM41464AP-12	40239
IC114	IC AY-3-8912	40001
IC115	IC AMS40464	40464
IC116	IC PC74HCTO2P	270999
IC301	IC LA6324	170112
Transistor		
Q101, 103-107, 301	TR KTC1815 Y-T	170447
Diodes		
D101	D LED SLZ-255B-21A/BT1	170866
D110, 111, 120-127, 201, 202	D 1SS132T-77	171582
D128-130	D MTZ4.7BT-77 ZENER	175021
D301	D 1N4002 RECT	175440
Coils and Inductors		
L101	Filter Line ESD-R-12C	270751
L301	Coil Inductor LAL03TA820K	270798
Switches		
SW101	Switch Keyboard ESU44LN027AA (UK)	270779
SW101	Switch Keyboard ESU44LN027DA (Spain)	270795
SW101	Switch Keyboard ESU44LN027CA (France)	270794
SW102	Switch Slide ESD-3975	170002
SW301	Switch Slide CL106A	270753
SW302	Switch Leaf LSA-1115TN	270755
PCB's		
PCB101	PCB ASSY MC0122	
PCB102	PCB ASSY MS0189	
PCB103	PCB ASSY MS0190	
PCB301	PCB ASSY MT0003	
PCB401	PCB ASSY MC0121	
Miscellaneous		
NR102	Res. Network EXB-P88222J	270800
PD001	Paddle 140Z001-40991	270792
RY301	Relay G4S-1112P-1-B-19	170123
X102	Crystal CX0-824C 40MHz	270772
CTD01	Cassette Deck TN-21ZH-754	270775
345	RF Belt	270805
347	Main Belt	270807
350	Motor	270858
Jacks		
J101	Jack Modular 215876-1	271010
J102	Jack Din CSK150-81-30-244	271011
J103	Jack RCA 3.5 HSJ1061-01-440	271012
J104	Jack DC HEC0470-01-640	271008
J105	Socket IC DILB40P-1115TN	
Variable Resistors		
VR101 VRSF	VG042M102	271609

Ref. No.	Description	Part No.
Resistors: Carbon 1/6W		
22 OHM	R105, 189, 192	152156
33 OHM	R146-154, 156, 157, 168, 169	152158
82 OHM	R180	152164
91 OHM	R172	152165
120 OHM	R181	152167
150 OHM	R113	152168
220 OHM	R187, 195, 198	152170
330 OHM	R175	152172
470 OHM	R186	152174
680 OHM	R174, 182	152176
910 OHM	R171	250430
1K OHM	R104, 161-163, 190	152179
1.2K OHM	R173	152180
1.1K OHM	R102, 103, 115, 116, 118-120	152183
3.3K OHM	R176-178, 184, 188	152185
4.7K OHM	R101, 127, 210	152188
5.6K OHM	R183	152189
10K OHM	R114, 117, 129, 130, 158-160, 164, 167	152194
15K OHM	R179	152196
22K OHM	R165, 166, 191	152198
100K OHM	R194, 197	152209
180K OHM	R123-126	152212
220K OHM	R193, 196	152213
Resistors: Carbon 1/4W		
56 OHM	R301	240507
100 OHM	R310	193588
560 OHM	R307	193196
820 OHM	R318	10054
3.3K OHM	R315, 319	193597
4.7K OHM	R314, 317	240510
5.6K OHM	R309	10079
10K OHM	R304, 308	240511
12K OHM	R312	10087
18K OHM	R302, 306	193700
33K OHM	R313, 316	193703
47K OHM	R303	240512
470K OHM	R305	193708
1M OHM	R311	193710
Resistors: Metal 1/6W		
1K OHM	R132, 134, 136, 138, 140, 142	271025
2K OHM	R131, 133, 135, 137, 139, 141, 143, 144	271026
6.34K OHM	R170	270785
Capacitors: Ceramic		
33PF 50V	C302	150514
100PF 50V	C127, 131	24016
200PF 50V	C307	240234
330PF 50V	C124, 125	193722
0.001UF 50V	C306	157679
0.022UF 50V	C309	21027
0.1UF 12V	C101, 102, 108, 110, 111, 114, 115, 117, 118, 401	175181
Capacitors: Electrolytic		
0.47UF 50V	C305	157670
1UF 50V	C137, 138	157563
10UF 16V	C126, 132, 134, 310	157581
22UF 10V	C304	270042
47UF 16V	C151	157629
100UF 10V	C135	193226
100UF 16V	C301	157568
470UF 10V	C130, 136, 308	270963
Capacitors: Polyester		
0.047UF 10V	C1303	170442

6128 ELECTRICAL ADJUSTMENT

LUMI. SIGNAL OUTPUT LEVEL

1. Connect the oscilloscope to 3 pin of J102.
2. Adjust VR101 so that the signal becomes 1.65V as shown in Fig. 1.

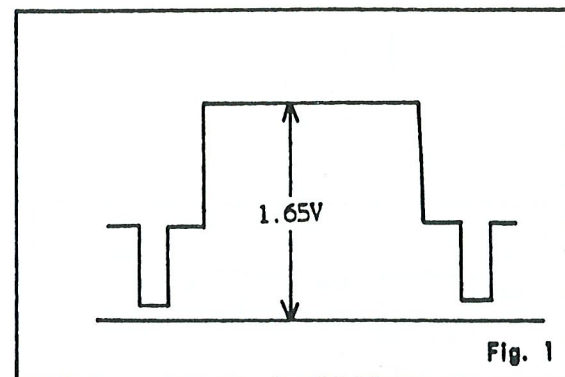

MAJOR COMPONENTS LOCATION GUIDE

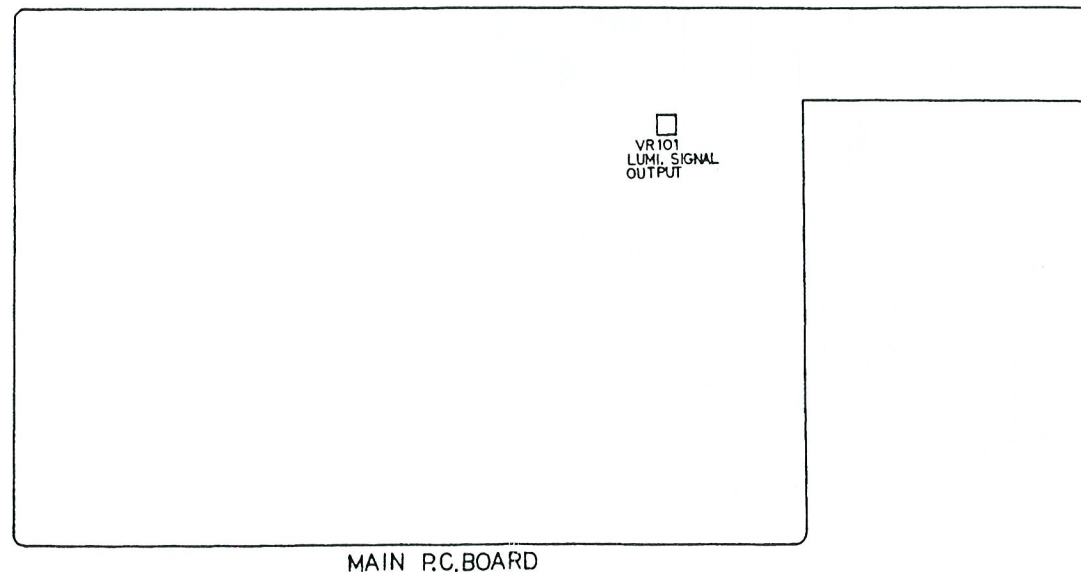

6128 PLUS TECHNICAL SPECIFICATION

LSI CHIPS

Z80A processor running at 4MHz.
 128K of RAM arranged in two 64K banks (over 41K available when using BASIC, 61K available to CP/M Plus).
 128K byte ROM cartridge containing BASIC firmware and "Burnin' Rubber" game.
 GI AY-3-8912 3 voice, 8 octave sound generator chip.
 Application Specific Integrated Circuit (ASIC) containing 18,000 gates.
 Includes emulation of 6845 video controller and 8255 parallel peripheral interface. Chip also contains 16,000 bits of storage for sprite data.
 upd765A disk controller.
 3" 170K built-in disk drive compatible with CPC models. Supplied disk contains CP/M Plus operating system.
 36 way Amphenol connector for second disk drive.

DISPLAY SPECIFICATION (BASIC)

Display Mode	Mode 1	Mode 2	Mode 3
No. of colours	4 from 27	2 from 27	16 from 27
Vertical dots	200	200	200
Horiz. dots	320	640	160
Characters	40 × 25	80 × 25	20 × 25

DISPLAY SPECIFICATION (CARTRIDGE GAMES)

16 mode independent sprites are available in 16 different colours from those used to draw the main screen.
 Both sprite colours and main screen colours may now be chosen from a palette of 4096. (16 levels of Red, Green and Blue).

Display Mode	Mode 1	Mode 2	Mode 3
No. of colours	4 from 4096	2 from 4096	16 from 4096
No. Sprites	16	16	16
Sprite colours	16 from 4096	16 from 4096	16 from 4096

EXTRA FEATURES (CARTRIDGE GAMES)

Analogue joystick support.
 Soft Scroll allows pixel-wise movement in vertical and horizontal for fast action games.
 Split Screen allows two separate areas to be displayed at once alleviating the need to re-draw score bars etc.
 DMA driven sound allows tunes to play without processor intervention.
 Raster Interrupt allows games to change mode and colours at fixed points on the screen.

KEYBOARD

74 keys – QWERTY style, numeric cluster, cursor and copy cursor, large enter, shift, caps lock, tab, escape, delete, clear, control.

DATAORDER

Write speed software selectable – 1K baud or 2K baud, read speed automatically established by software. Write protect interlock. Motor on/off controlled by software.

ADD-ON ABILITY

8 bit Centronics compatible printer.
 1 or 2 digital joysticks or paddles.
 IBM Standard analogue joystick. (Some cartridge games).
 Light gun.
 Various peripherals.
 ROM cartridge up to 512K byte capacity.

EXTERNAL SOCKETS

3.5 mm stereo jack plug for connection to external amplifier.
 2 × 9 Pin D-type digital paddle/joystick connectors.
 15 Pin D-type analogue joystick connector (IBM Standard).
 RJ11 "telephone" jack for connection of light gun.
 25 way D-type connector for 8 bit Centronics interface.
 50 way Amphenol style connector with full Z80 bus for addition of other devices (e.g. serial interface).
 8 Pin DIN socket for RGB, sync, Luminance and stereo sound connection to monitor.
 5 mm socket for connection of 5V power supply for monitor.

DIMENSIONS mm (approx.)

	Width	Height	Depth
Computer	398	46	297
MM12 mono motor	329	308	307
CM14 colour monitor	377	348	360
Paddle controller	124	22	56

POWER SUPPLY

MM12 Monitor: 240V AC (UK), 220V AC (Europe) 50Hz.
 CM14 Monitor: 220-240V AC 50Hz.

PRINTED CIRCUIT BOARDS
MAIN/CASSETTE HOLD/LED

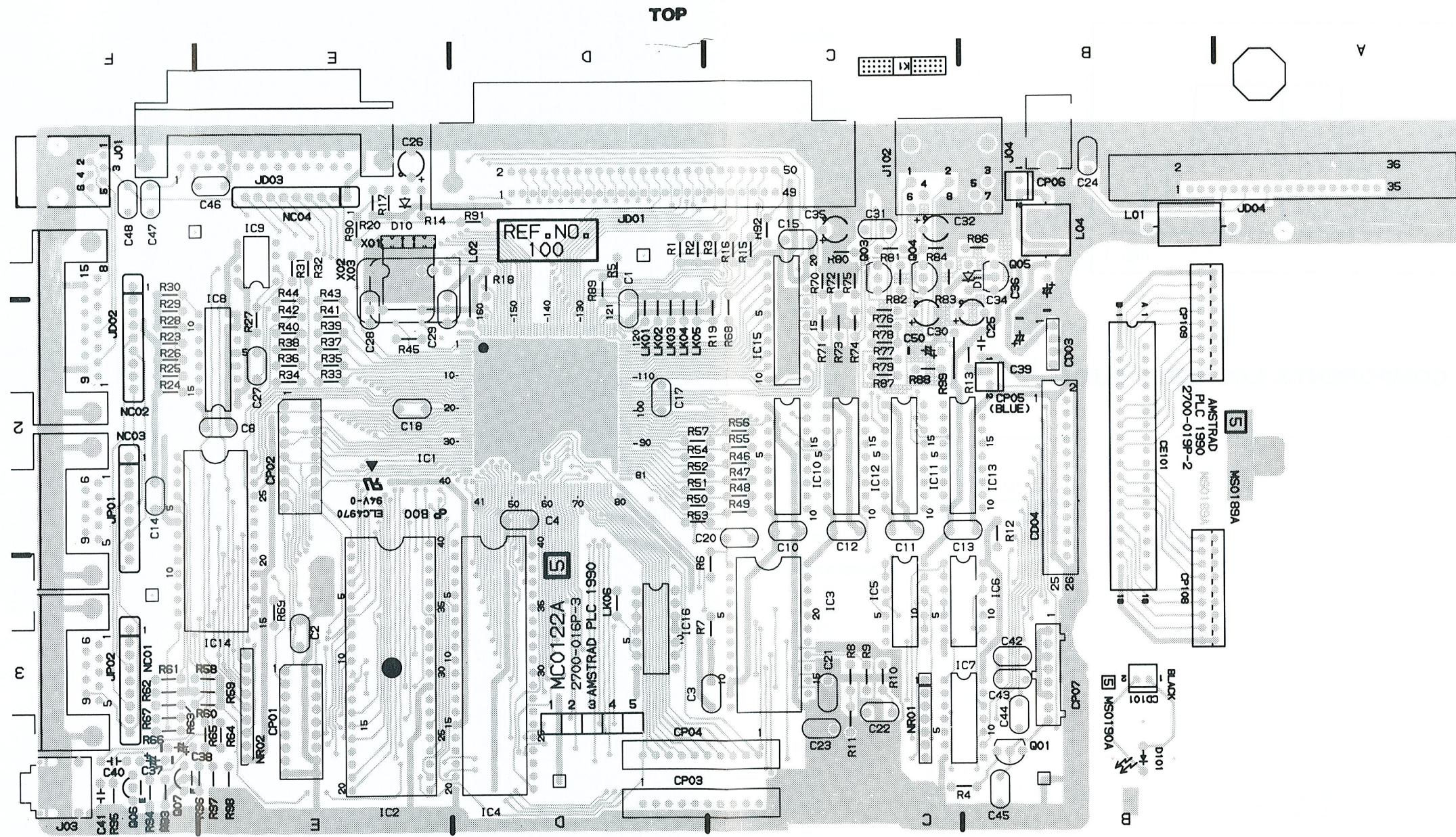

PRINTED CIRCUIT BOARD
MAIN/CASSETTE HOLD/LED

BOTTOM

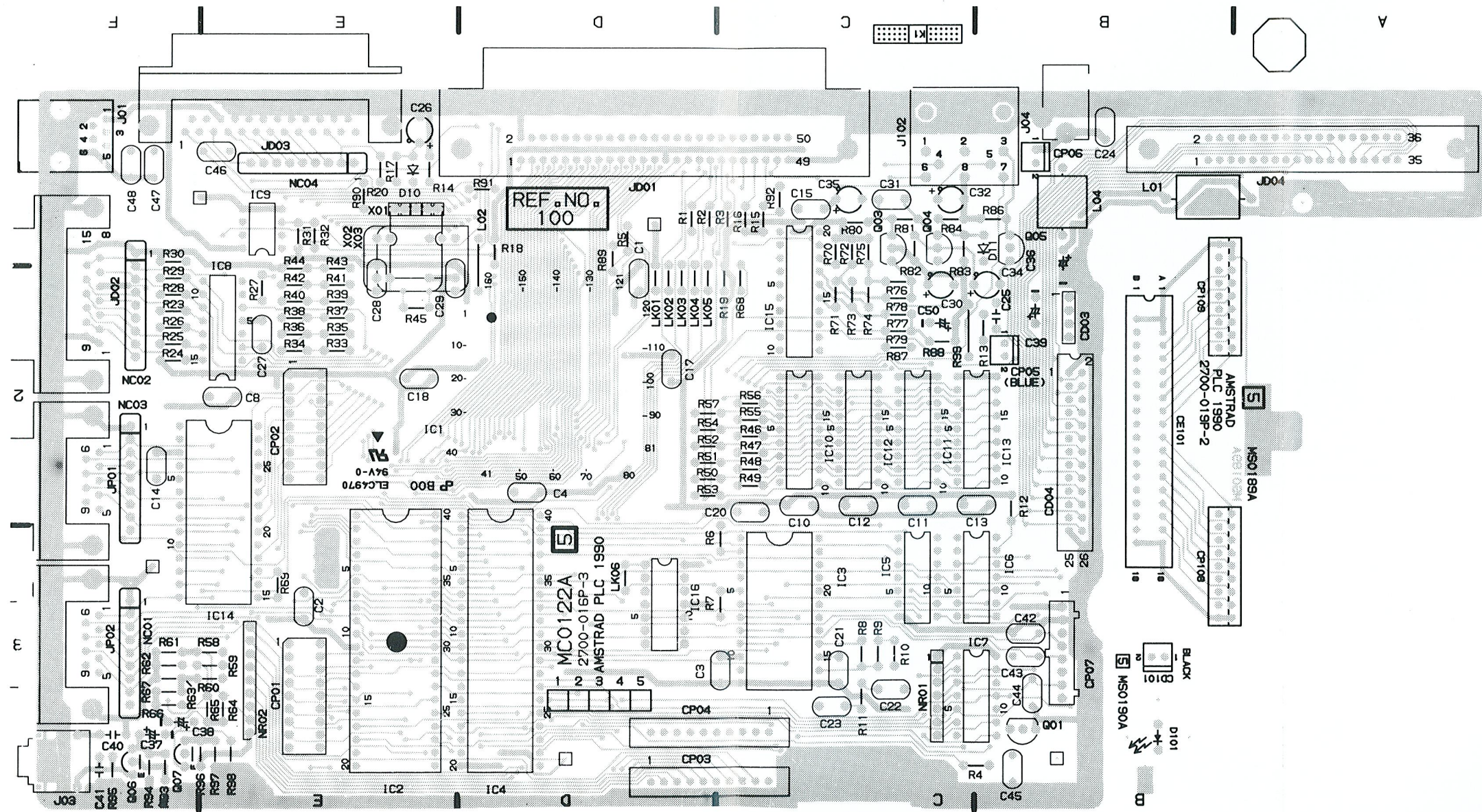

GATE ARRAY / OUTPUT INTERFACE SCHEMATIC DIAGRAM

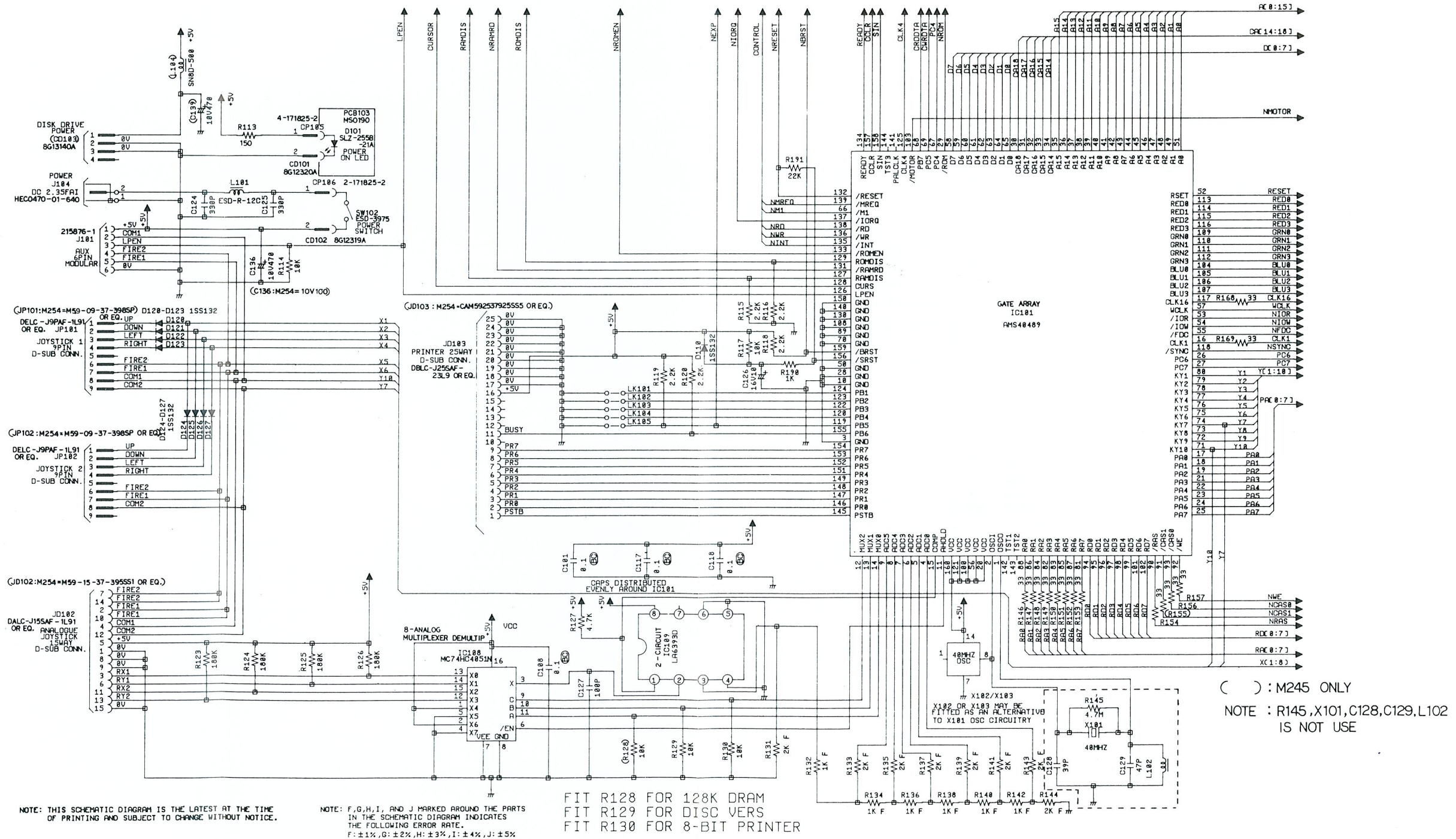

CPU / CONNECTION INTERFACE SCHEMATIC DIAGRAM

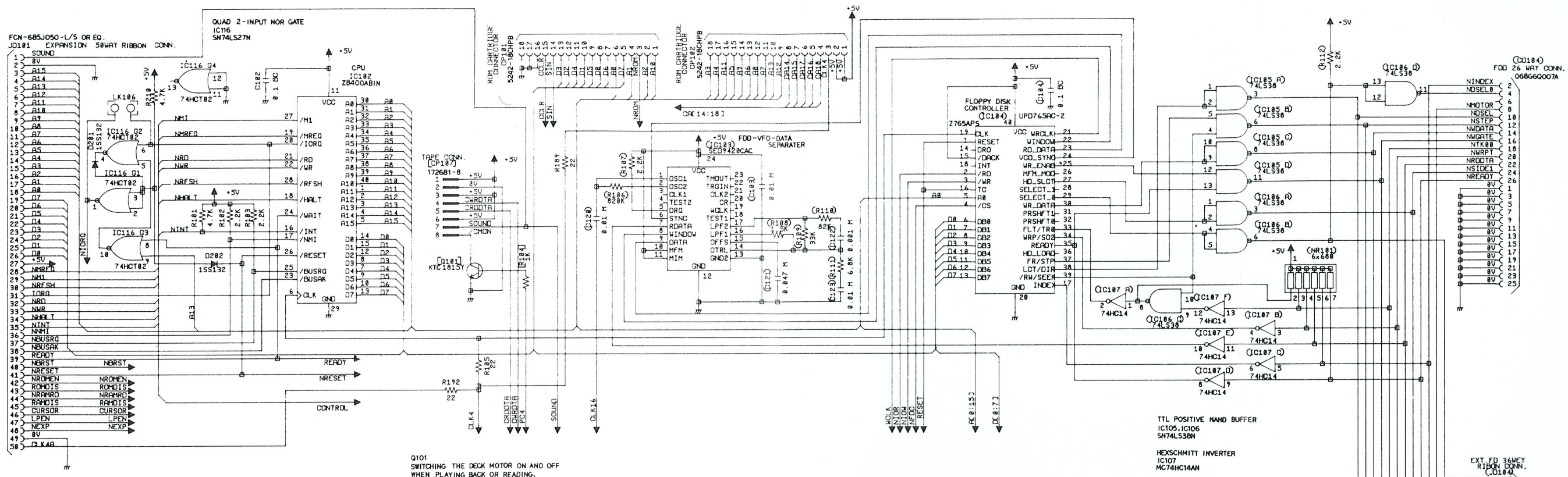

Q101 SWITCHING THE DECK MOTOR ON AND OFF WHEN PLAYING BACK OR READING.

TTL POSITIVE NAND BUFFER
IC105, IC106
SN74LS30N

HEX SCHMITT INVERTER
IC107
MC74HC14AN

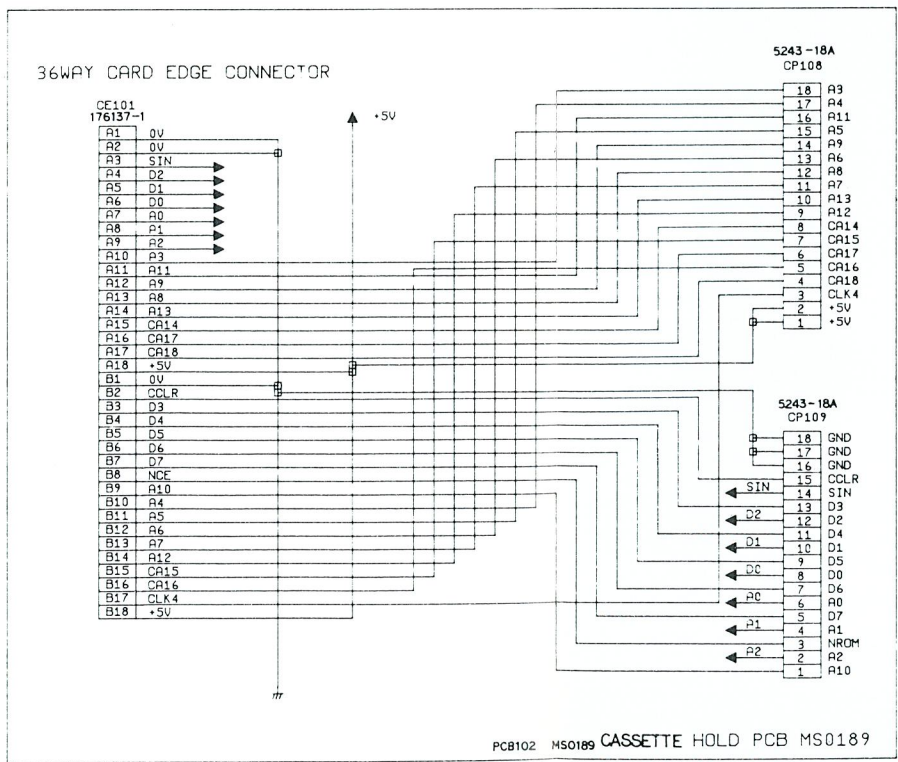

() : M254 ONLY
[] : M253 ONLY

NOTE: THIS SCHEMATIC DIAGRAM IS THE LATEST AT THE TIME OF PRINTING AND SUBJECT TO CHANGE WITHOUT NOTICE.

VIDEO CONVERSION / MEMORY SCHEMATIC DIAGRAM

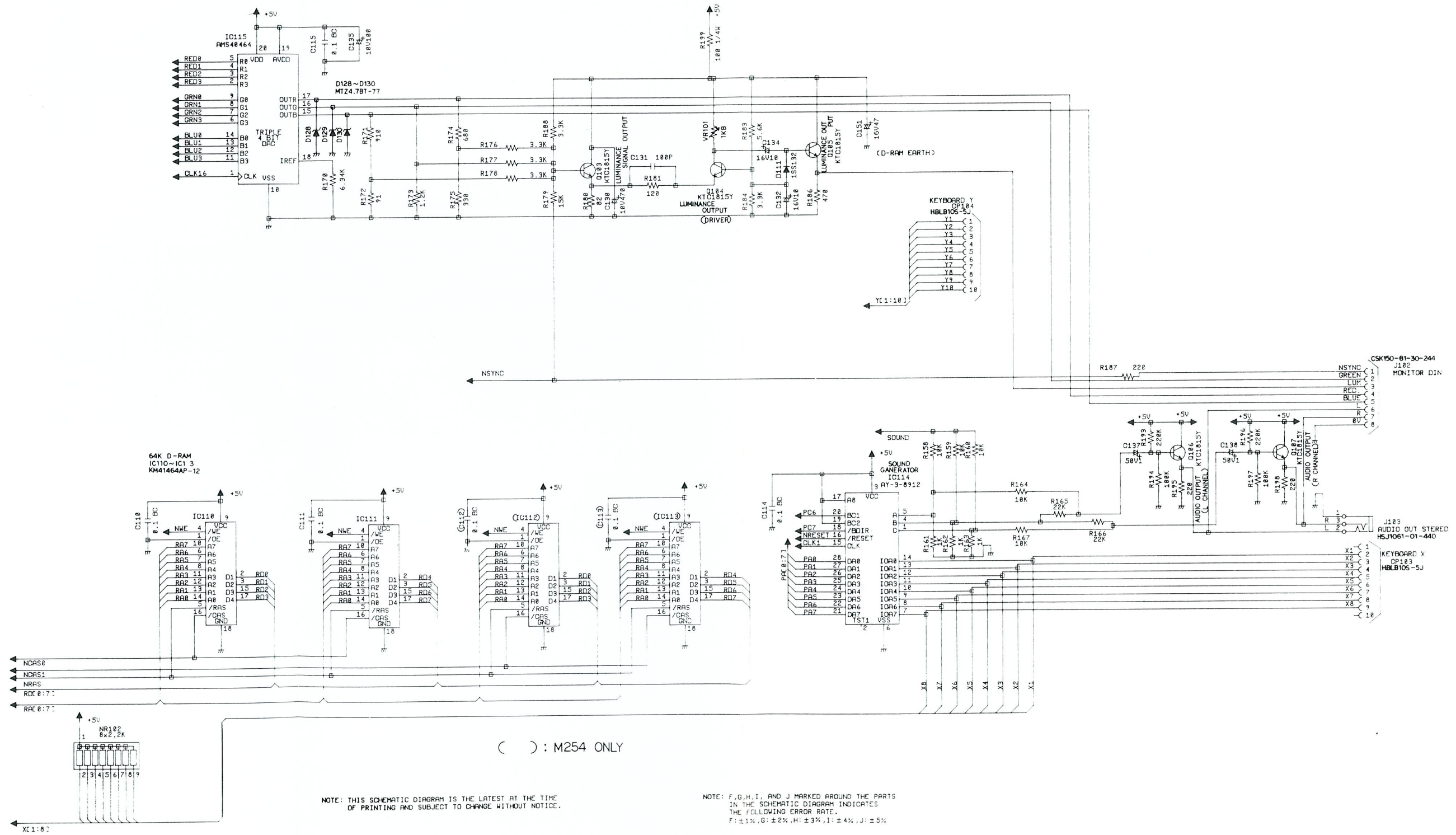

MECHANICAL EXPLODED VIEW

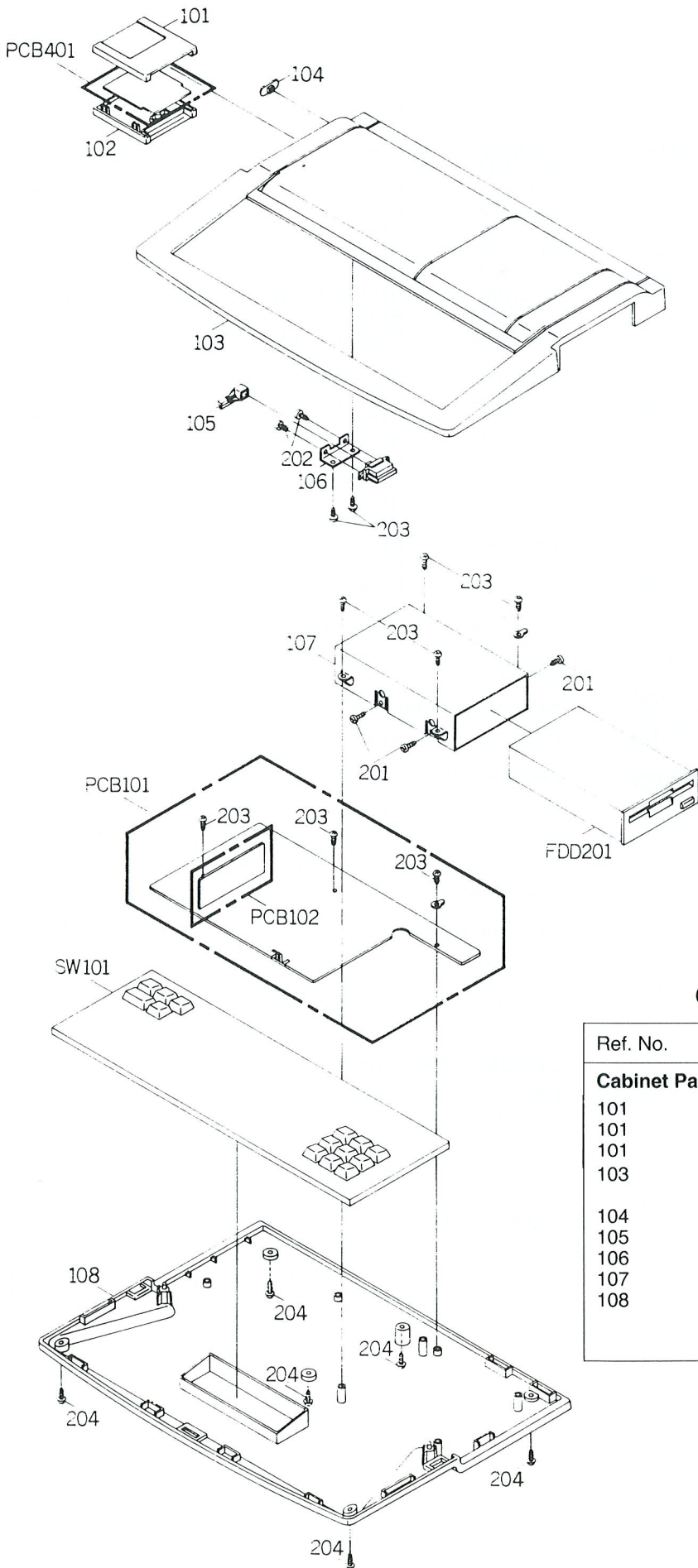

6128 PLUS CABINET PARTS LIST

Ref. No.	Description	Part No.
Cabinet Parts		
101	Cartridge Assy UK	410891
101	Cartridge Assy France	410901
101	Cartridge Assy Spain	410911
103	Cabinet Top ASSY	270773
	Cabinet Top	
104	Button Power (A)	271618
105	Button Power (B)	271619
106	Bracket Power Switch	271620
107	Frame FDD	271621
108	Cabinet Bottom Assy	270774
	Leg Rubber	
	Sheet Rating	

6128 PLUS ELECTRICAL PARTS LIST

Ref. No.	Description	Part No.
IC's		
IC101	IC AMS40489	40489
IC102	IC Z840GAB1N	40080
IC103	IC SED 9420CAC	171034
IC104	IC Z765APS	40018
IC105, 106	IC SN74LS38N	190056
IC107	IC MC74HC14AN	193024
IC108	IC MC74HC4051N	270752
IC109	IC LA6393D	270997
IC110-113	IC KM41464AP-12	40239
IC114	IC AY-3-8912	40001
IC115	IC AMS40464	40464
IC116	IC PC74HCT02P	170112
Transistor		
Q103-107	TR KTC1815 Y-T	170447
Diodes		
D101	D LED SLZ-255B021A/BT1	170866
D110, 111, 120-127, 201, 202 D128-130	D 1SS132T-77 D MTZ4.7BT-77	171582 175021
Coils and Inductors		
L101	Filter Line ESD-R-12C	270751
L301	Coil Choke SN8D-500	271605
Switches		
SW101	Switch Keyboard ESU44LN027AA (UK)	270779
SW101	Switch Keyboard ESU44LN027DA (Spain)	270795
SW101	Switch Keyboard ESU44CN027CA (France)	270794
SW102	Switch Slide ESD-3975	170002
PCB's		
PCB101	PCB ASSY MC0122	
PCB102	PCB ASSY MS0189	
PCB103	PCB ASSY MS0190	
PCB401	PCB ASSY MC0121	
Miscellaneous		
CFD101	CFD Ansoft 3" EBFCF2SS1AR5	271610
FDD201	FDD EME-157	271611
NR101	Res. Network EXB-F7E681J	270862
NR102	Res. Network EXB-P88222J	270800
PD001	Paddle 140Z001-40991	270792
X102	Crystal CXO-824C 40MHz	270772
Jacks		
J101	Jack Modular 215876-1	271010
J102	Jack DIN CSK150-81-30-244	271011
J103	Jack RCA 3.5 HSJ1061-01-440	130010
J104	Jack DC HEC0470-01-640	271008
J105	Socket IC DILB40P-8J	176096
Variable Resistors		
VR101	VRSF VG042M102	270753

Ref. No.	Description	Part No.
Resistors: Carbon 1/8W		
1.5 OHM	R108	152140
22 OHM	R105, 189, 192	152156
33 OHM	R146-157, 168, 169	152158
82 OHM	R180	152164
91 OHM	R172	152165
120 OHM	R181	152167
150 OHM	R113	152168
220 OHM	R187, 195, 198	152170
330 OHM	R175	152172
470 OHM	R186	152174
680 OHM	R174, 182	152176
910 OHM	R171	250430
1K OHM	R161-163, 190	152179
1.2K OHM	R173	152180
2.2K OHM	R102, 103, 107, 112, 115, 116, 118-120	152183
3.3K OHM	R176-178, 184, 188	152185
4.7K OHM	R101, 127	152188
5.6K OHM	R183	152189
6.8K OHM	R111	152190
10K OHM	R114, 117, 128-130, 158-160, 164, 167	152194
15K OHM	R179	152196
22K OHM	R165, 166, 191	152198
33K OHM	R109	152200
82K OHM	R110	152207
100K OHM	R194, 197	152209
180K OHM	R123-126	152212
220K OHM	R193, 196	152213
470K OHM	R210	152217
820K OHM	R106	152221
Resistors: Carbon 1/4W		
100 OHM	R199	193588
Resistors: Metal 1/8W		
1K OHM	R132, 134, 136, 138, 140, 142	271025
2K OHM	R131, 133, 135, 137, 139, 141, 143, 144	271026
6.34K OHM	R170	270785
Capacitors: Ceramic		
100PF 50V	C127, 131	24016
330PF 50V	C124, 125	193722
0.1UF 12V	C101, 102, 104, 108, 110, 111-115, 117, 118, 401	175181
Capacitors: Electrolytic		
1UF 50V	C137, 138	157563
10UF 16V	C126, 132, 134	157581
47UF 16V	C151	157629
100UF 10V	C135, 136	193226
470UF 10V	C130, 139	270963
Capacitors: Polyester		
0.001UF 50V	C122	240250
0.01UF 50V	C120, 123, 103	250419
0.047UF 10V	C121	170442

GX4000 TECHNICAL SPECIFICATION

LSI CHIPS

Z80 processor running at 4MHz.
 64K RAM.
 128K byte ROM cartridge containing "Burnin' Rubber" game.
 GI AY-3-8912 3 voice, 8 octave sound generator chip.
 Application Specific Integrated Circuit (ASIC) containing 18,000 gates.
 Includes emulation of 6845 video controller and 8255 parallel peripheral interface. Chip also contains 16,000 bits of storage for sprite data.

ADD-ON ABILITY

1 or 2 digital joysticks or paddles.
 IBM Standard analogue joystick. (Some cartridge games).
 Light gun.
 ROM cartridge up to 512K byte capacity.

DISPLAY SPECIFICATION

16 mode independent sprites are available in 16 different colours from those used to draw the main screen.
 Both sprite colours and main screen colours may now be chosen from a palette of 4096. (16 levels of Red, Green and Blue).

Display Mode	Mode 1	Mode 2	Mode 3
No. of colours	4 from 4096	2 from 4096	16 from 4096
No. Sprites	16	16	16
Sprite colours	16 from 4096	16 from 4096	16 from 4096

EXTRA FEATURES

Analogue joystick support.
 Soft Scroll allows pixel-wise movement in vertical and horizontal for fast action games.
 Split Screen allows two separate areas to be displayed at once alleviating the need to re-draw score bars etc.
 DMA driven sound allows tunes to play without processor intervention.
 Raster Interrupt allows games to change mode and colours at fixed points on the screen.

EXTERNAL SOCKETS

3.5 mm stereo jack plug for connection to external amplifier.
 2 x 9 Pin D-type digital paddle/joystick connectors.
 15 Pin D-type analogue joystick connector (IBM Standard).
 RJ11 "Telephone" jack for connection of light gun.
 Phono socket for UHF TV connection – lead supplied.
 8 Pin DIN socket for RGB, sync, Luminance and stereo sound connection to monitor.
 21 Pin Scart/Peritel socket for direct connection to TV.
 6 mm socket for connection of 5V power supply from monitor*.
 6 mm socket for connection of AC adaptor (AC adaptor supplied).

* GX4000 can be connected to MM12 or CM14 monitor and powered from the monitor.

DIMENSIONS mm (approx.)

	Width	Height	Depth
GX4000	250	44	184

POWER SUPPLY

GX4000 PSU AC adaptor 220V (EURO) 240V (UK) 50 Hz.

ELECTRICAL ADJUSTMENT

FREQUENCY

1. Connect the set to a normal TV set with the RF cable.
2. Insert the cartridge into the set.
3. Adjust the coil in the RF modulator of set so that letters are shown in the picture.

MAIN P.C.B. (Top View)

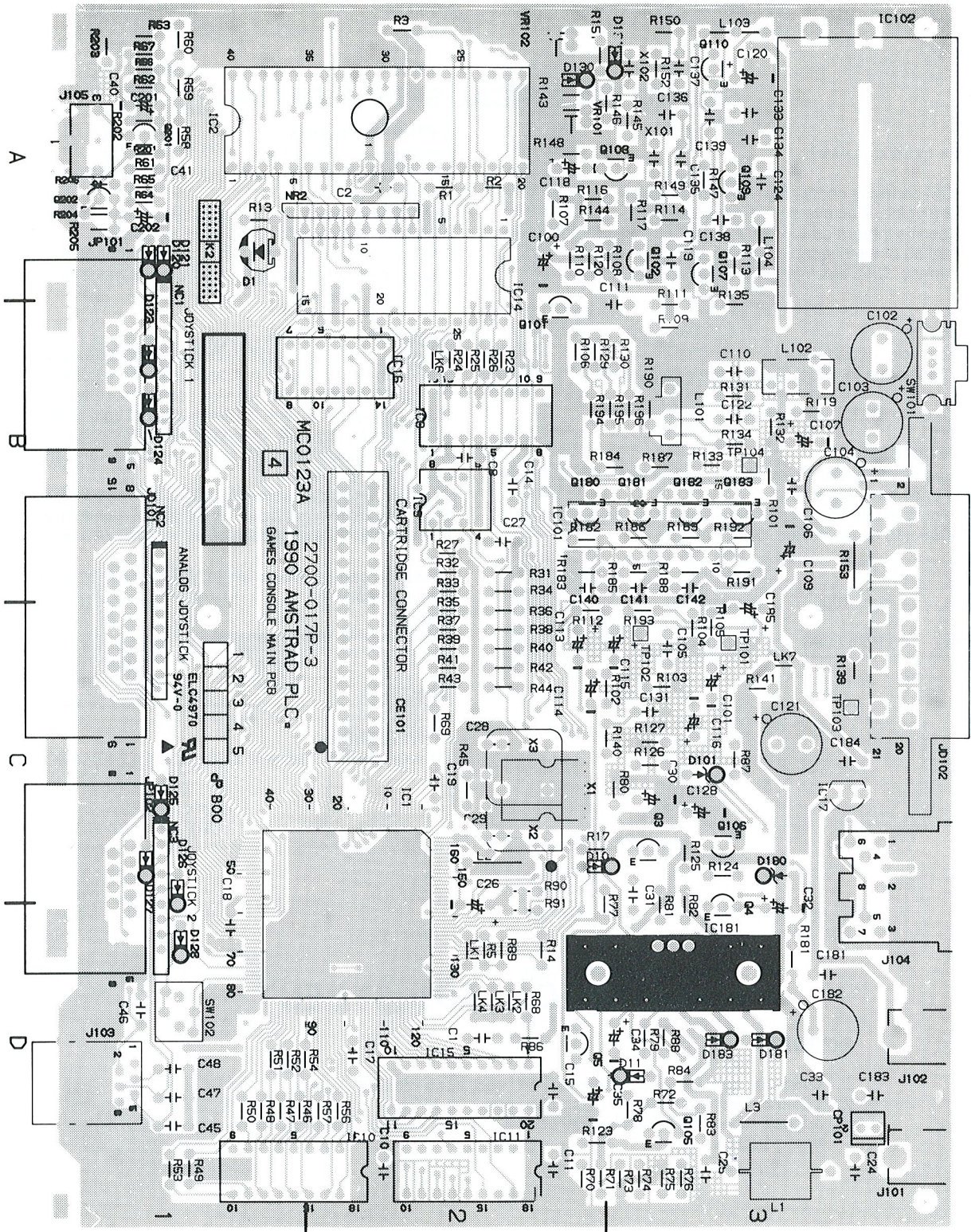

BOTTOM

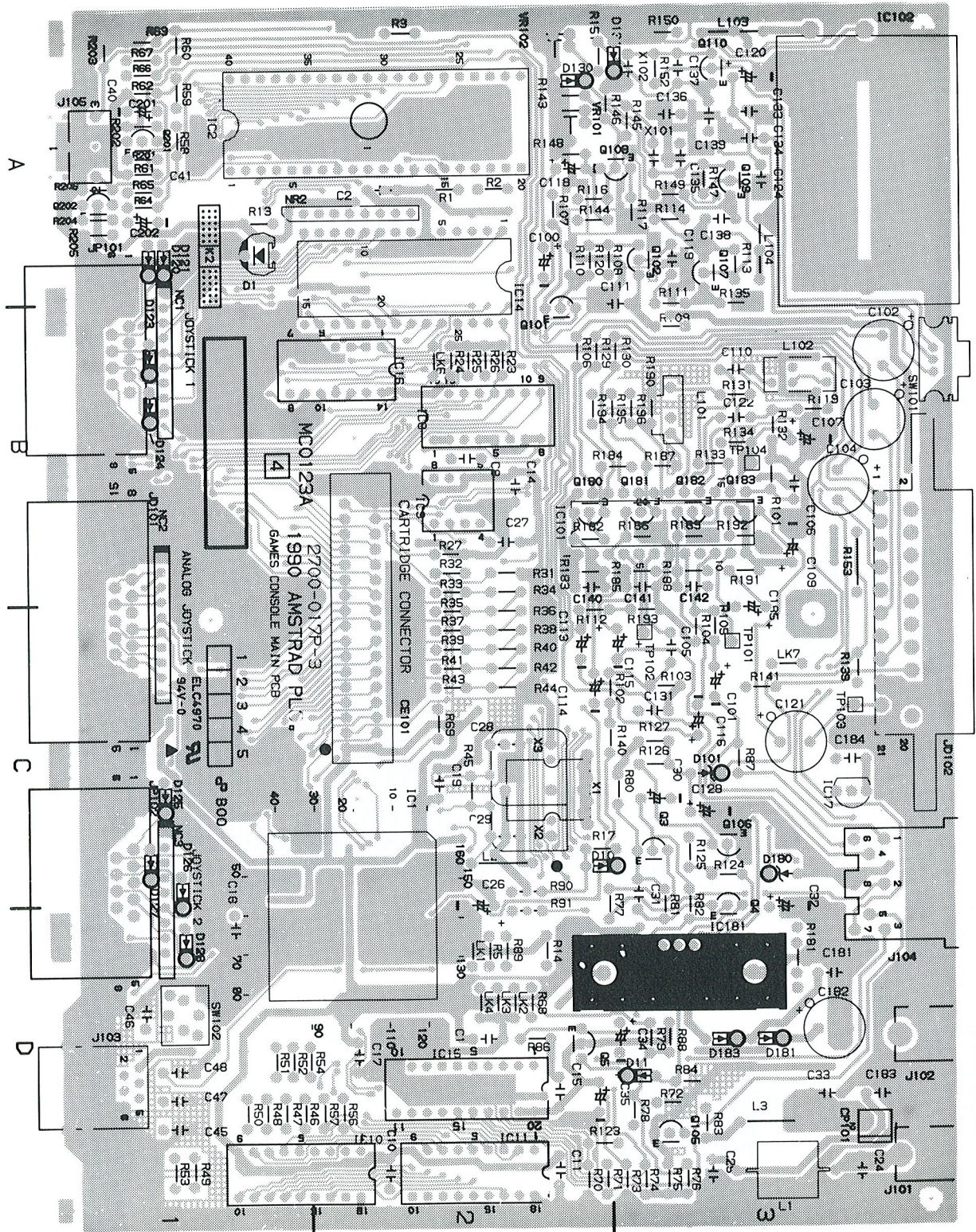

GATE ARRAY / OUTPUT INTERFACE SCHEMATIC DIAGRAM

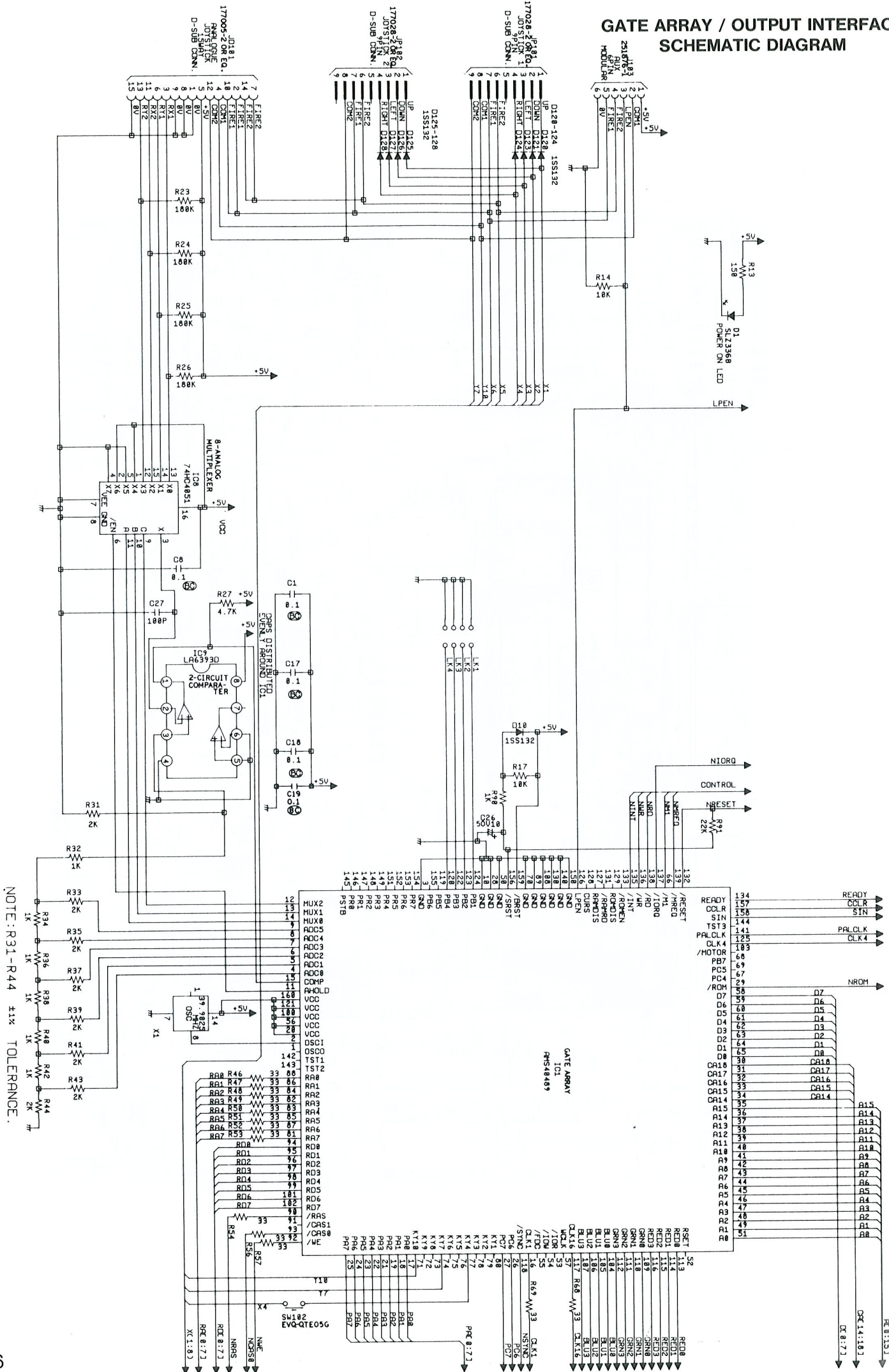

CPU / CONNECTION INTERFACE SCHEMATIC DIAGRAM

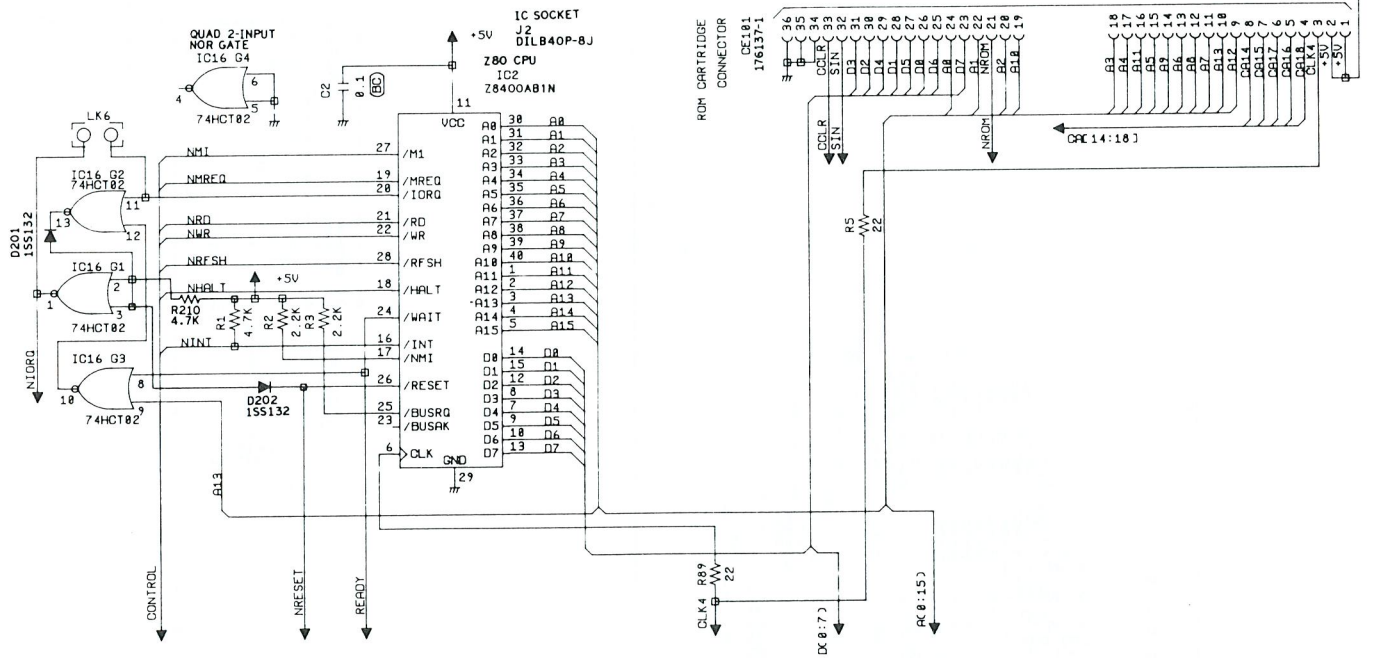

VIDEO CONVERSION / MEMORY SCHEMATIC DIAGRAM

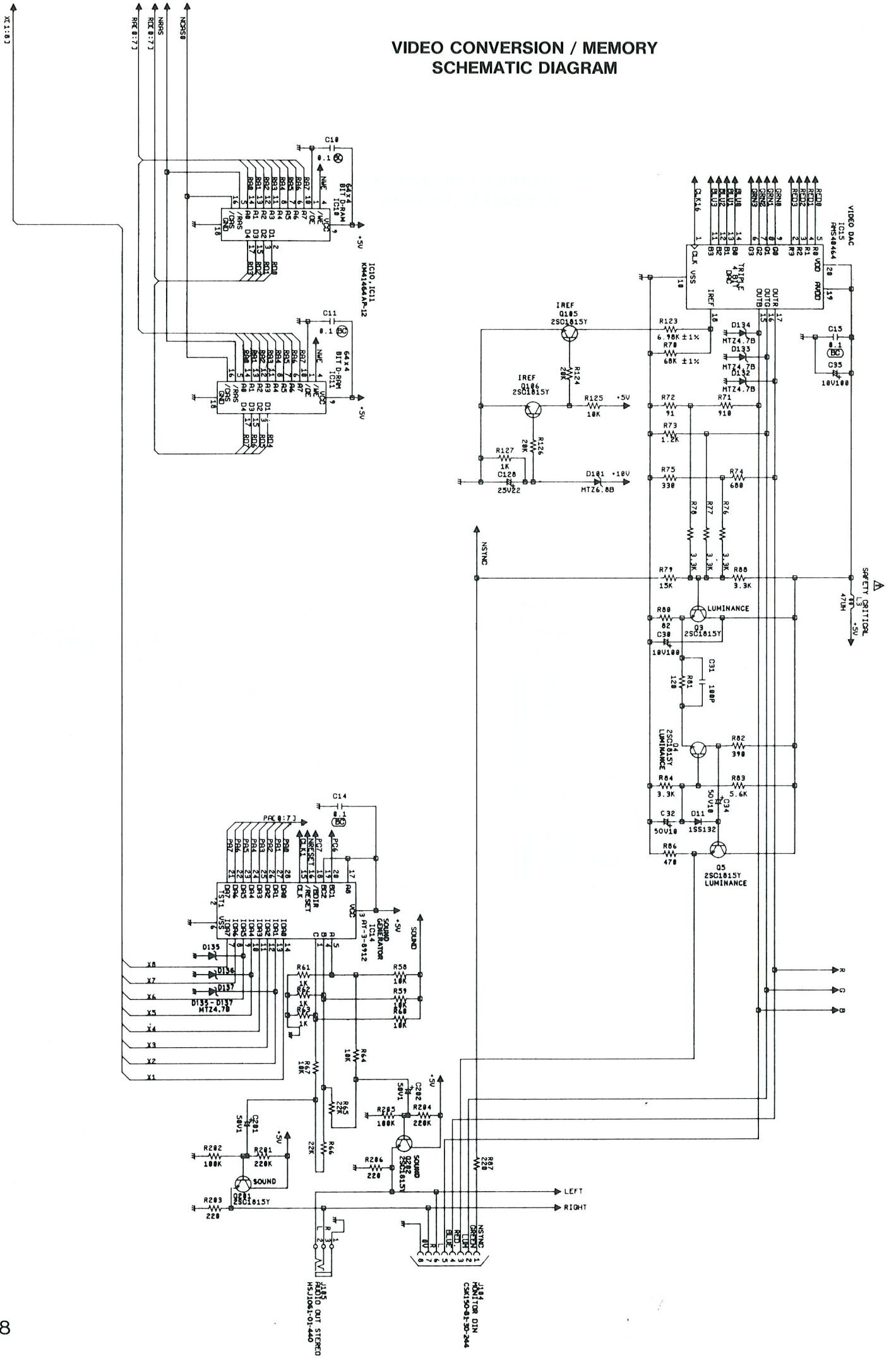

POWER REGULATOR SCHEMATIC DIAGRAM

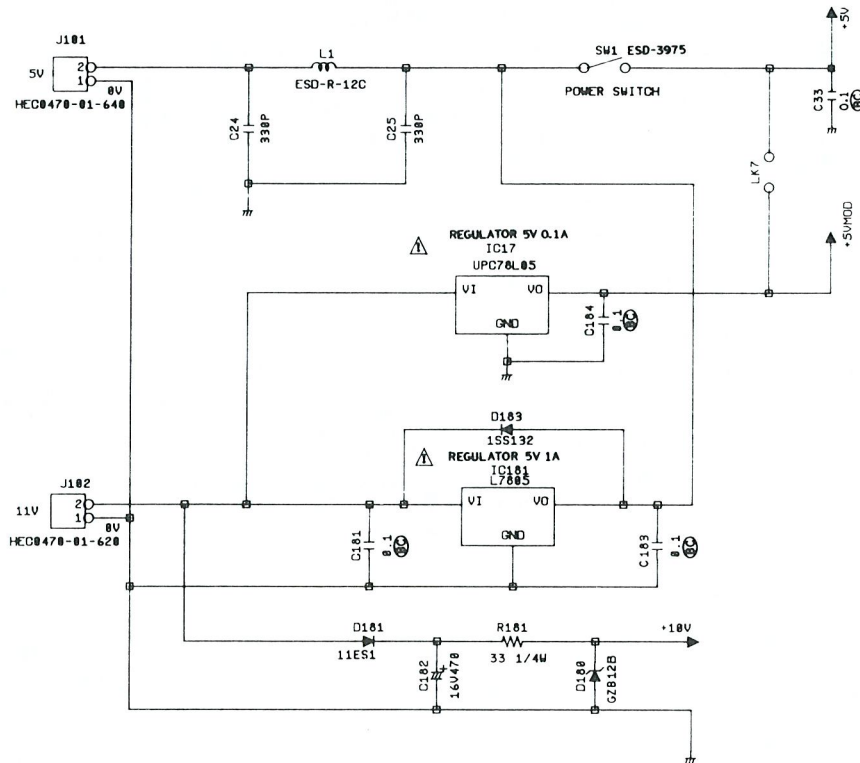

SCHEMATIC DIAGRAM

RGB CONVERTER

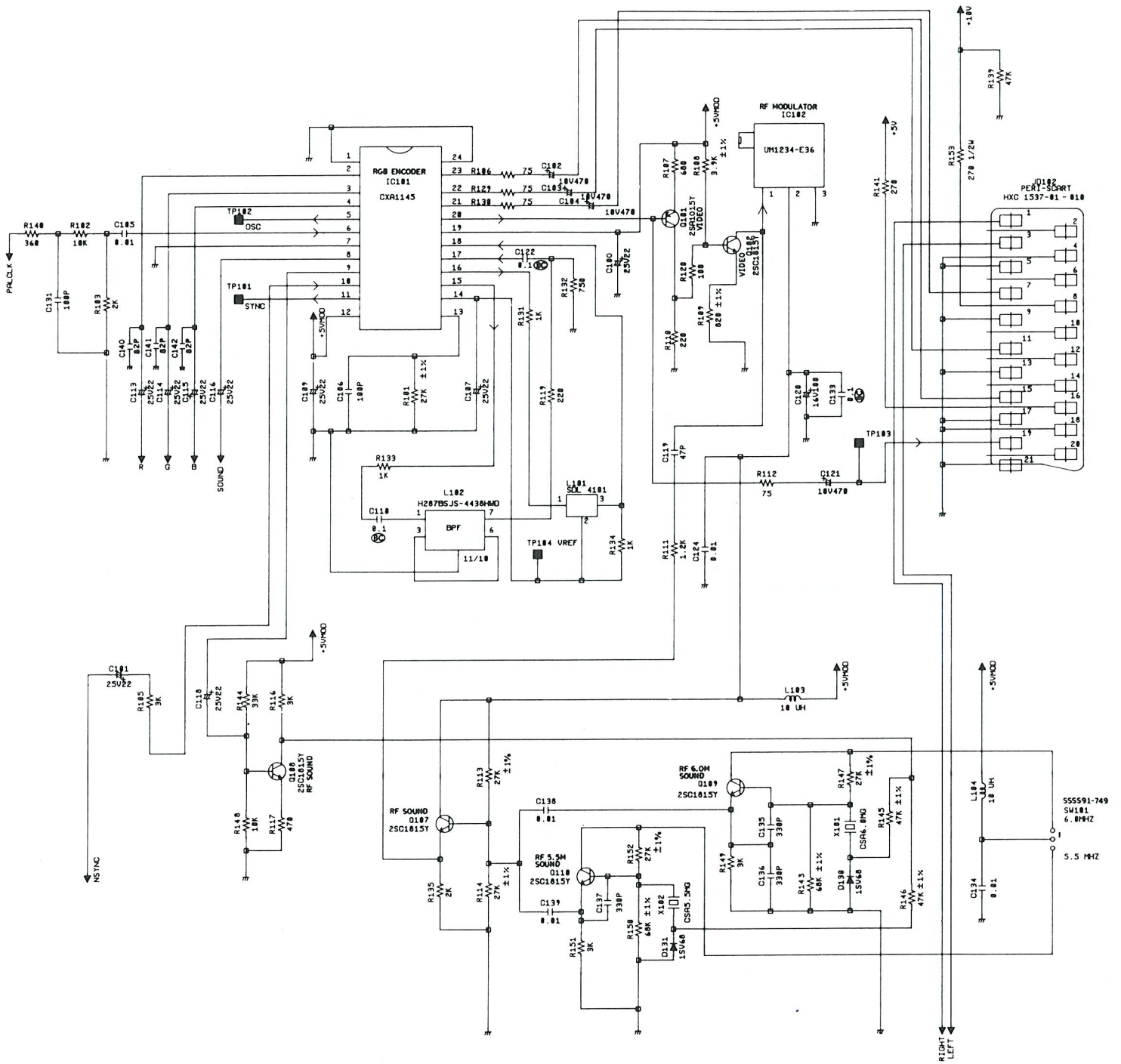

GX4000 CABINET EXPLODED VIEW

GX4000 CABINET PARTS LIST

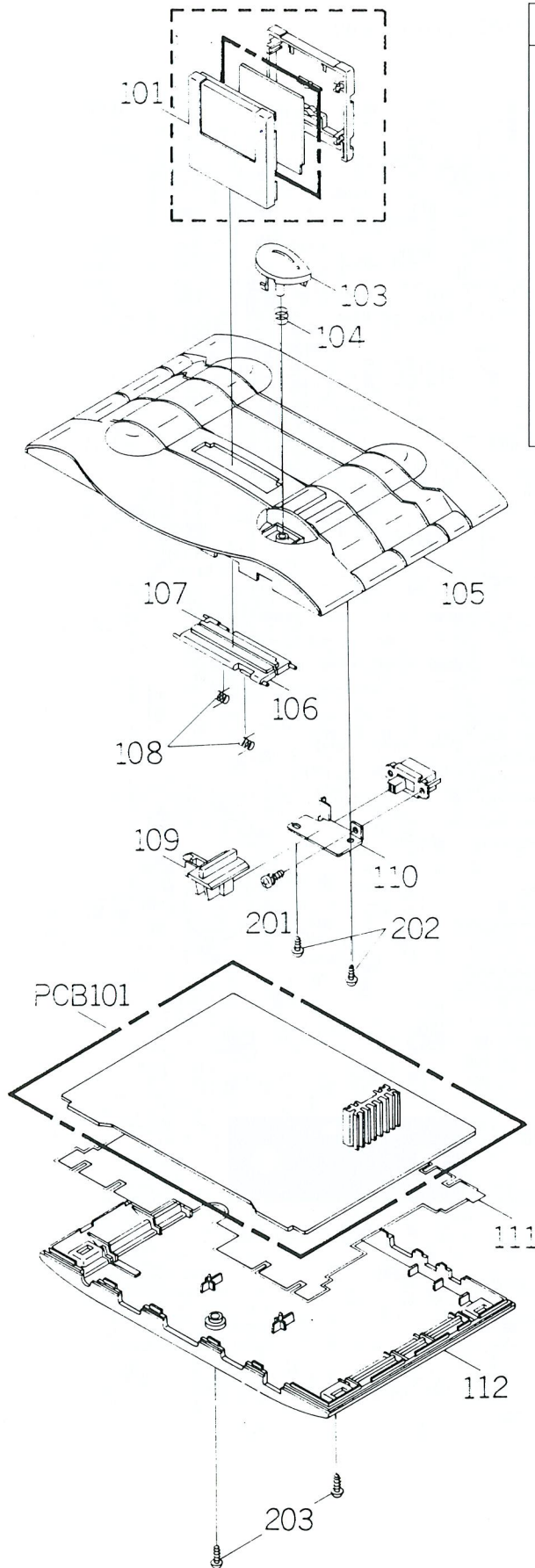

Ref. No.	Description	Part No.
Cabinet Parts		
101	Cartridge Case Assy (UK/FR/SP)	41088
103	Knob, Power/Lock	270970
104	Spring Button	271018
105	Top Cabinet Ass'y	270960
	Cabinet Top	
	Glass LED	
	Plate Brand	
106	Flap A	270969
107	Flap B	271000
108	Spring Flap	271019
109	Knob Slide	270966
110	Angle Power Switch	270968
111	Plate Shield	271020
112	Bottom Cabinet	270964
	Label, Rating Plate	270972
	Leg Rubber	270965

MAIN P.C.B. FRANCE (Top View)

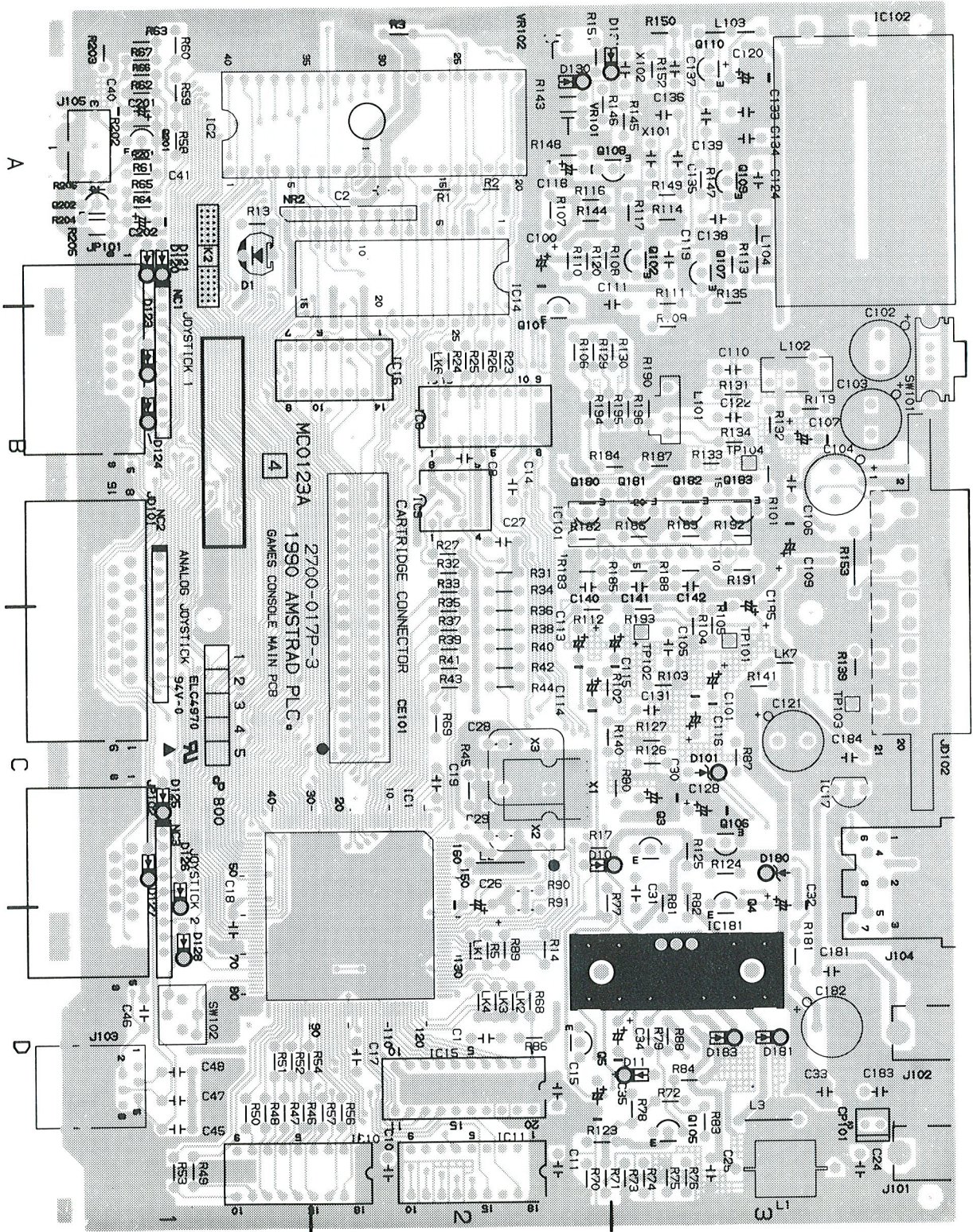

MAIN P.C.B. FRANCE (Bottom View)

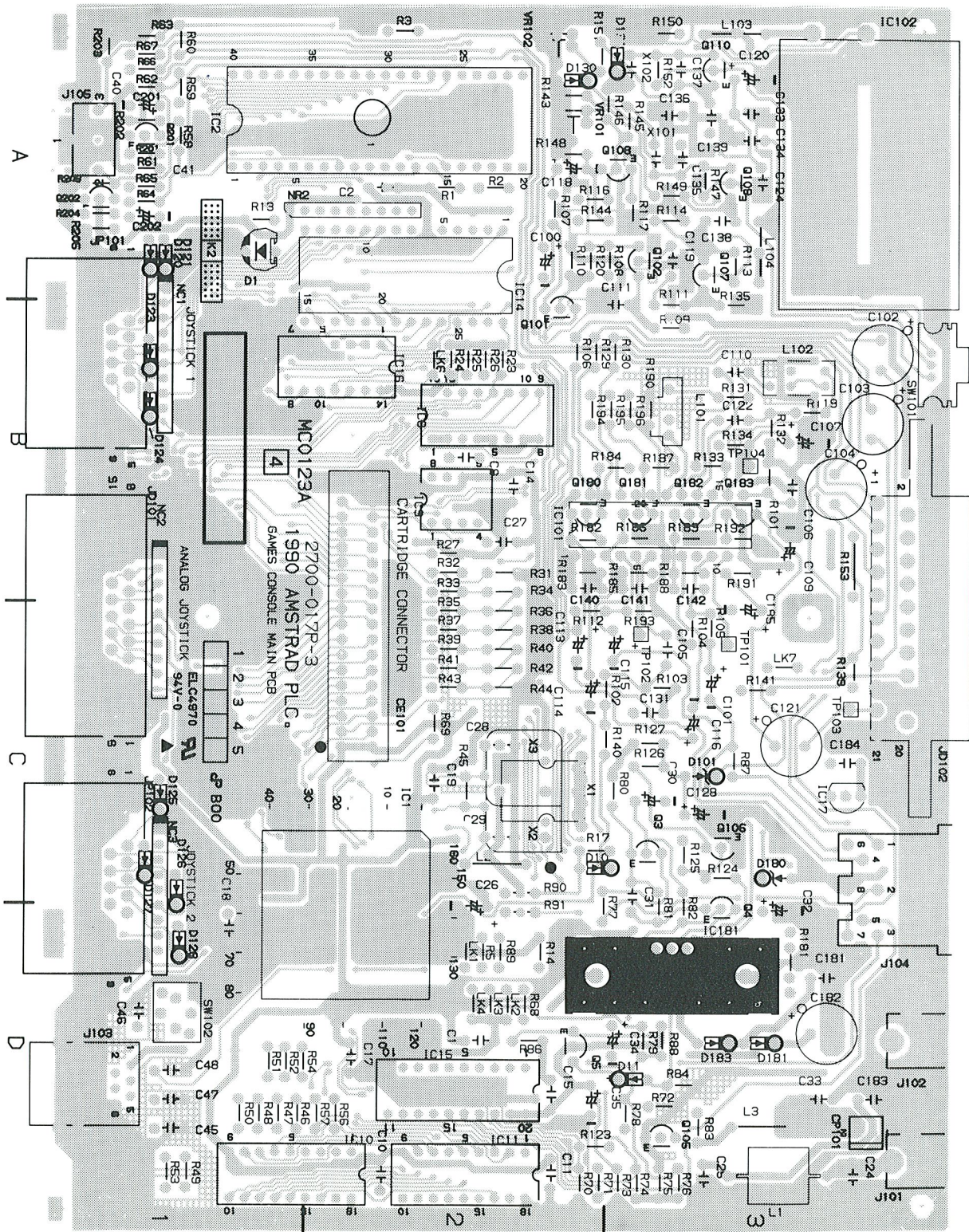

POWER REGULATOR SCHEMATIC DIAGRAM (FRANCE)

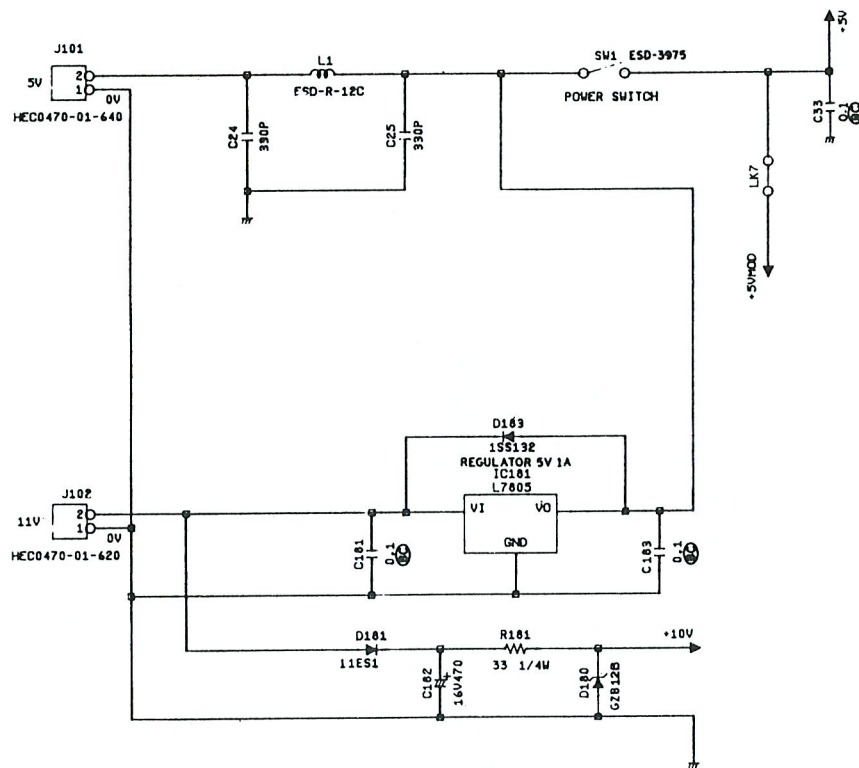

OUTPUT INTERFACE (FRANCE)

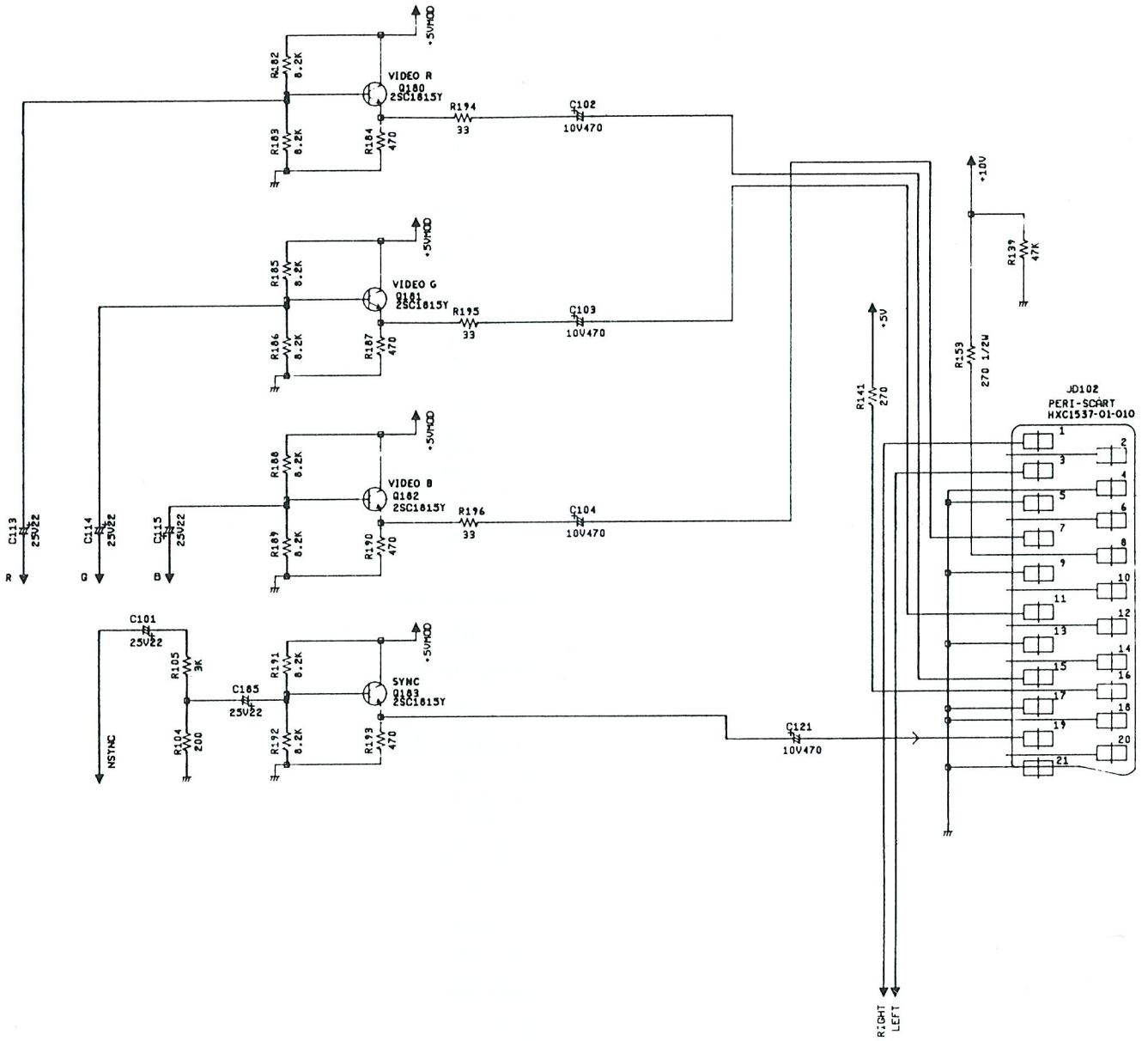

GX4000 ELECTRICAL PARTS LIST

Ref. No.	Description	Part No.
IC's		
IC1	IC AMS40489 Gate Array	40489
IC2	IC Z8400AB1N CPU	40080
IC8	IC MC74HC4051N ANA Multi	270996
IC9	IC LA6393D Dual Op Amp	170112
IC10, 11	IC KM41464AP-12 4064 RAM	173001
IC14	IC AY-3-8912 Sound Generator	40001
IC15	IC AMS40464 Video DAC	40464
IC16	IC PC74HCTO2P Quad Norgate	270999
IC17	IC UPC78L05 Reg SVOIA	190731
IC101	IC CXA1145P RGB Encoder	270975
IC102	IC UM1234E36 RF Modulator	271001
IC181	IC L7805 Reg SVIA	271002
IC401	IC AMS40982 Cartridge Gate Array	40982
IC402	IC AMS40908 Cartridge Gate Array	40908
Transistors		
Q3-5, 102, 105-110, 201, 202	TR 2SC1815Y, Silicon	177910
Q101	TR 2SA1015Y Silicon	170453
Diodes		
D1	D SLZ336B-16A/B-T1 LED	271003
D10, 11, 120, 121, 123-128, 183, 201, 202	D 1SS132 T	171582
D101	D MTZ6.8BT-77	171488
D130, 131	D 1SV68, Variable Cap.	271004
D132-137	D MTZ4.7BT-77	175021
D180	D GZB12B, ZENER	271005
D181	D 11ES1TA1, Silicon	271006
Coils		
L1	Filter Line ESD-R-12C	270751
L3	Coil Inductor LAL03KH470K	270992
L101	Delay Line SDL4101	270993
L102	Filter Band Pass H287BSJS-4438HWD	270994
L103, 104	Coil 10UH	175940
Switches		
SW1	Switch Slide ESD-3975	170002
SW101	Switch Slide SSSS91-749	270990
SW102	Switch Tact EVQ-QTE05G	270991
PCB's		
PCB101	PCB ASS'Y MC0123	
PCB401	PCB ASS'Y MC0121	
Miscellaneous		
J2	Socket IC DILB40P-8J	271007
J101	Jack DC HEC0470-01-640	271008
J102	Jack DC HEC0470-01-620	271009
J103	Jack Modular 215876-1	271010
J104	Jack DIN CSK150-81-30-244	271011
J105	Jack RCA 3.5 HSJ1061-01-440	271012
PD001	Paddle	270792
X1	Crystal CX0-824C 39.9025MHZ	271013
X101	Ceramic Oscillator CSA6.0MG	271014
X102	Ceramic Oscillator CSA5.5MG	271015
	Manual, Multi-Lingual	U1-GX4000
	AC Adapter, UK	270974
	AC Adapter, Euro	270973
	Cartridge Assy	41088

Ref. No.	Description	Part No.
Resistors: Carbon 1/8W		
22 OHM	R5, 89	152156
33 OHM	R46-54, 56, 57, 68, 69	152158
75 OHM	R106, 112, 129, 130	152163
82 OHM	R80	152164
91 OHM	R72	152165
100 OHM	R120	152166
120 OHM	R81	152167
150 OHM	R13	152168
220 OHM	R87, 110, 119, 203, 206	152170
270 OHM	R141	152171
330 OHM	R75	152172
360 OHM	R140	271021
390 OHM	R82	152173
470 OHM	R86, 117	152174
680 OHM	R74, 107	152176
750 OHM	R132	152177
910 OHM	R71	240204
1K OHM	R61-63, 90, 127, 131, 133, 134	152179
1.2K OHM	R73, 111	151180
2K OHM	R103, 135	271022
2.2K OHM	R2, 2	152183
3K OHM	R105, 116, 149, 151	271023
3.3K OHM	R76-78, 84, 88	152185
4.7K OHM	R1, 27, 210	193789
5.6K OHM	R83	152189
10K OHM	R14, 17, 58-60, 64, 67, 102, 125, 148	152194
15K OHM	R79	152196
20K OHM	R124, 126	157639
22K OHM	R65, 66, 91	152198
47K OHM	R139	152203
68K OHM	R143	152205
100K OHM	R202, 205	152209
180K OHM	R23-26	152212
220K OHM	R201, 204	157641
Resistors: Carbon 1/4W		
33 OHM	R181	174852
Resistors: Metal 1/2W		
270 OHM	R153	176748
Resistors: Metal 1/6W		
820 OHM	R109	271024
1K OHM	R32, 34, 36, 38, 40, 42	271025
2K OHM	R31, 33, 35, 37, 39, 41, 43, 44	271026
3.9K OHM	R108	271027
6.98K OHM	R123	271028
27K OHM	R101, 113, 114, 147, 152	271029
33K OHM	R144	271030
47K OHM	R145, 146	178036
68K OHM	R70, 143, 150	271031
Capacitors: Ceramic		
47PF	C119	150515
82PF 50V	C140-142	270035
100PF 50V	C27, 31, 106, 131	240221
330PF 50V	C24, 25, 135-137	150518
0.01UF	C105, 124, 134, 138, 139	157577
0.1UF 12V	C1, 2, 8, 10, 11, 14, 15, 17-19, 33, 110, 122, 133, 181, 183, 184, 401	240223
Capacitors: Electrolytic		
1UF 50V	C201, 202	157563
10UF 50V	C26, 32, 34	240462
22UF 25V	C100, 101, 107, 109, 113-116, 118, 128	250409
100UF 10V	C30, 35, 120	240463
470UF 10V	C102-104, 121	270983
470UF 16V	R182	157630

ELECTRICAL ADJUSTMENTS

MM-12 SECTION

1. BEFORE MAKING ELECTRICAL ADJUSTMENTS

Read and perform these adjustments when repairing the circuits or replacing electrical parts.

CAUTION

Use an isolation transformer when performing any service on this chassis.

Before removing the anode cap, discharge electricity because it contains high voltage.

When removing a PCB or related component, after unfastening or changing wire, be sure to put wire back in its original position.

1-1: Prepare the following measurement tools for electrical adjustments.

1. Frequency Counter
2. DC Voltmeter

2. BASIC ADJUSTMENTS

2-1: DC 12V

1. Get the screen of initial pattern on screen from PC.
2. Set the bright and contrast controls to maximum position.
3. Connect the hot the digital voltmeter to TP501.
4. Adjust the VR502 so that the digital voltmeter indicates DC $12.00 \pm 0.05V$.

2-2: DC 5V

1. Put the following loads in the DC cord and set to the following values by using VR501.

LOAD	SETTING VALUE
Load 2.4A	DC $4.80 \pm 0.05V$
Load $3.6 \pm 0.4A$	DC 0V
No load(0A)	Less than 5.25V

2-3: H-HOLD

1. Shut off the input signal and set the screen to the free-run condition.
2. Connect a frequency counter to CRT heater.
3. Adjust VR407 to obtain 15.625KHz reading.

2-4: SUB BRIGHT

1. Set the bright and contrast controls to minimum position.
2. Adjust VR402 until letters of initial pattern on screen can be seen slightly.

2-5: V SIZE

1. Get the screen of border 26 pattern from PC.
2. Set the bright and contrast controls to maximum position.
3. Adjust the VR406 so that the width "A" in border size become $152 \pm 2mm$. (Refer to Fig. 2-1)

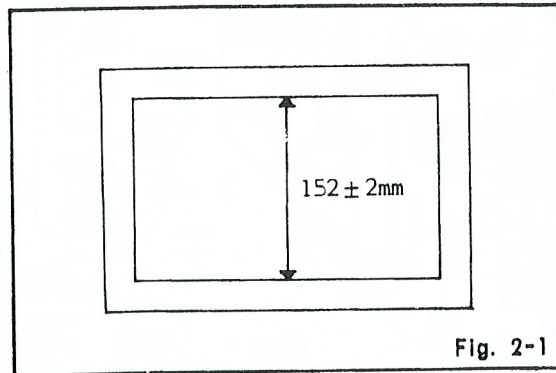

2-6: CENTERING

1. Set the bright and contrast controls to maximum position.
2. Get the screen of border 26 pattern from PC adjust it by means of the magnet on the back of DY so that it comes to the center of the screen.

MAJOR COMPONENTS LOCATION GUIDE

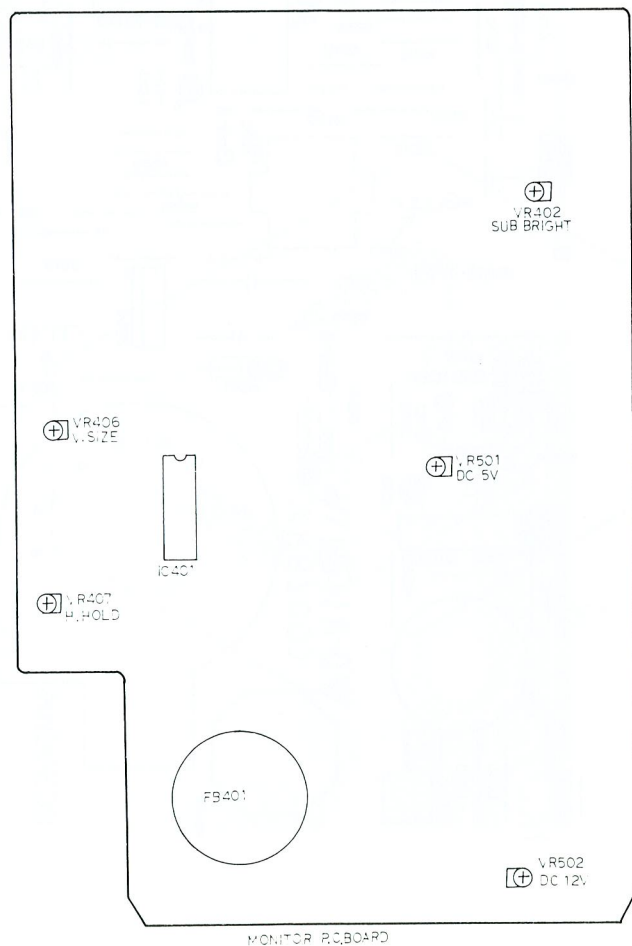

MM12 CABINET PARTS LIST

Ref. No.	Description	Part No.
Cabinet Parts		
101	Cabinet Ass'y	271173
	Cabinet Front	
	Plate Brand	
102	Button Power	271413
103	Spring Button (B)	271414
104	Angle Curl Cord	271415
105	Stopper PCB	271416
106	Knob Control	271417
107	Angle Trans.	271418
108	Cabinet Back Ass'y	271174
	Cabinet Back	
	Sheet Rating (ask for UK/Euro)	271419
109	Angle Heat Sink	
110	Cord Clamp No PEC-034-0	
111	Cord Clamp No P-45	
112	Sheet CRT Support	
113	Spring Earth	

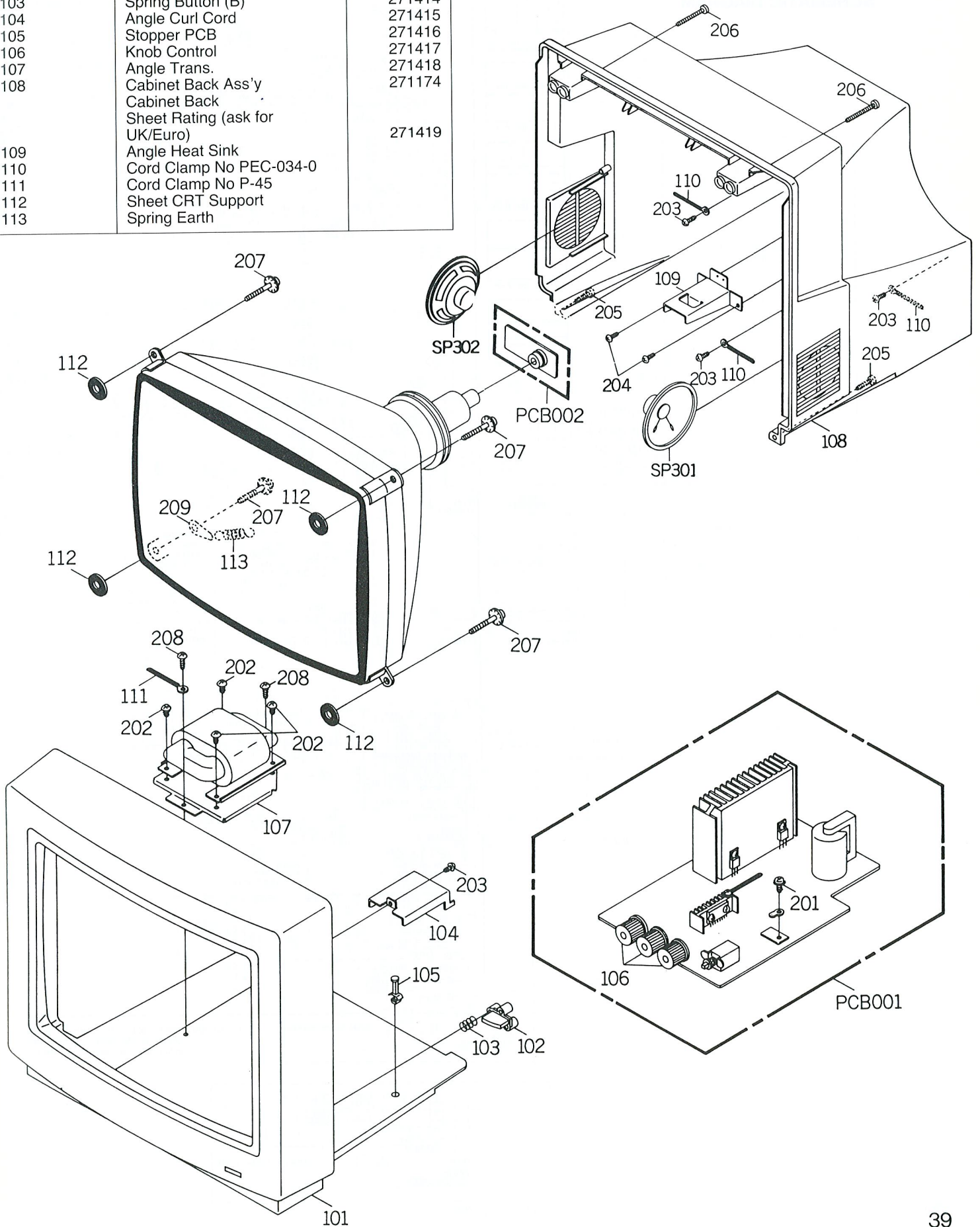

**MM-12 MONITOR / CRT
SCHEMATIC DIAGRAM**

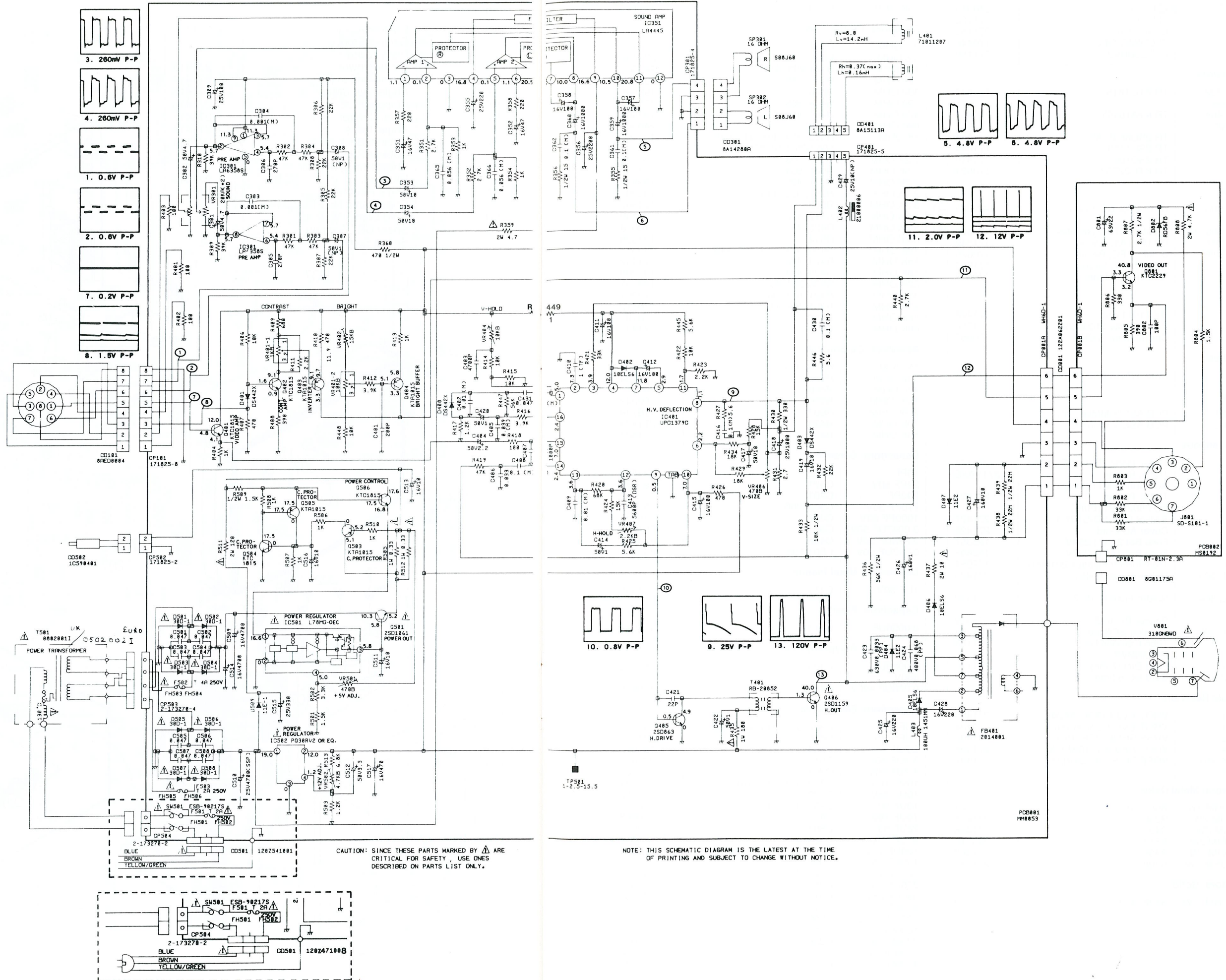

MM12 EURO

MM12 ELECTRICAL PARTS LIST

Ref. No.	Description	Part No.
IC's		
IC301	IC LA6358S	240015
IC351	IC LA4445	271162
IC401	IC UPC1379C	271163
IC501	IC L78MG-OEC	170446
IC502	IC PQ30RV2	271160
Transistors		
Q401, 402, 504, 506	TR KTC1815	170447
Q403, 404, 503, 505	TR KTA1015Y	170453
Q404	TR 2SD863E-AE	271164
Q406	TR 2SD1159	171044
Q501	TR 2SD1061	271410
Q801	TR KTC2229Y	170624
Diodes		
D401, 403, 408	D DS442X-BT, Silicon	1422117
D402, 405, 406	D 10ELS6TA1, Rectifier	171550
D404, 407	D 11E2TA1, Silicon	171049
D501-508	D 30D-1 FC, Rectifier	170625
D509	D 11E1TA1, Silicon	171050
D802	D RD56FB, Zener	170627
Coils		
L401	DY 71011207	271408
L402	Coil Linearity 21000006	171558
L403	Coil Inductor 100UH	175867
Switches		
SW501	Switch Push ESB-90217S	171511
PCB's		
PCB001	PCB ASS'Y MM0053-S	
PCB002	PCB ASS'Y MS0192	
Miscellaneous		
T401	Trans. Horiz. Drive RG-20852	271171
T501	Trans. Power AC 0408020011 (UK)	271170/S
T501	Trans. Power AC 05020021 (Euro)	271425
J801	Socket CRT SD-S101-1	271427
CV501	Cover AC Cord	271428
F501, 503	Fuse Bet 2A (T) 250V	193357
F502	Fuse Bet 4A (T) 250V	152603
FB401	Transformer Flyback 2014001	177054
FH501, 503, 505	Holder Fuse HO451	271429
FH502, 504, 506	Holder Fuse HO452	271430
S501	Spacer Bush-M	176849
SP301, 302	Speaker SO8J60	271169
V801	Tube Cathode Ray 310GNBWD	271168
CD101	Cord DIN (7 Pin)	271176
CD502	Cord DC 6.5mm	271177
Variable Resistors		
VR301	VROT EVJ-COOF25A24	271403
VR401	VROT EVU-G2AFA0007	271404
VR402	VRSF RHO632CE4R01	271405
VR404	VROT RK09K1110APPA	271406
VR406, 407, 501, 502	VRSF RH0638CS2R02A	271407
Resistors: Metal Oxide		
0.33 OHM 1W	R505, 512	271444
4.7 OHM 2W	R359	271445
10 OHM 2W	R437	271446
120 OHM 2W	R511	240216
180 OHM 1W	R435	271447
4.7K OHM 2W	R808	271448
Resistors: Solid		
22M OHM 1/2W	R438, 439	271449

Ref. No.	Description	Part No.
Resistors: Carbon 1/6W		
39K OHM	R309, 310	1420145
Resistors: Carbon 1/4W		
2.7 OHM	R431	271435
5.6 OHM	R427, 446	271436
100 OHM	R401-403, 418	240507
220 OHM	R357, 358	193589
330 OHM	R806	193591
390 OHM	R408, 805	271437
470 OHM	R407, 410, 426	193592
680 OHM	R409	240509
1K OHM	R353, 354, 404, 413, 449, 506-508, 510, 803	193594
1.2K OHM	R417, 503	271438
1.5K OHM	R501, 804	271439
2.2K OHM	R411, 423	193595
2.7K OHM	R351, 352, 440	193596
3.3K OHM	R502	193597
3.9K OHM	R412, 416	271440
5.6K OHM	R425, 445	10079
6.8K OHM	R513	193598
10K OHM	R406, 414, 415, 422, 448	240511
15K OHM	R424, 428	271442
18K OHM	R429, 434	193700
22K OHM	R305-308, 432	193701
33K OHM	R421, 801, 802	10097
47K OHM	R301-304, 419	240512
56K OHM	R447	10103
68K OHM	R420	271443
Resistors: Carbon 1/2W		
15 OHM	R355, 356	271432
330 OHM	R430	174834
470 OHM	R360	201711
1.5K OHM	R509	250047
2.7K OHM	R807	176749
10K OHM	R433	271433
56K OHM	R436	271434
Capacitors: Ceramic		
10PF	C802	193416
22PF 50V	C421	193719
200PF	C401	172179
270PF 50V	C305, 306	157677
1000PF 50V	C407	240222
0.0047UF 50V	C403	201719
0.033UF 50V	C406	153922
0.047UF 50V	C501-508	152645
Capacitors: Metal Plastic		
1UF 50V	C410	271455
Capacitors: Plastic		
0.0056UF	C413	174818
Capacitors: Polypropylene		
0.0033UF 630V	C423	157740
0.068UF 400V	C424	170620
Capacitors: Electrolytic		
1UF 50V	C307, 308, 414, 420, 422	157563
1UF 160V	C426	271450
2.2UF 50V	C404	157672
3.3UF 50V	C512	271451
4.7UF 50V	C301, 302	157565
10UF 16V	C419, 511, 513, 516	157581
10UF 25V	C429	271452
10UF 50V	C353, 354, 417	240462
10UF 160V	C427	170608
22UF 63V	C801	170609
47UF 16V	C351, 352	172074
100UF 16V	C357, 358, 411, 412, 415	157568
100UF 25V	C309	157569
220UF 16V	C425, 428	240464
220UF 25V	C355	152565
330UF 25V	C515	170836
470UF 16V	C517	157630
1000UF 16V	C359, 360	271453
1000UF 25V	C418	152567
2200UF 25V	C356	157653
4700UF 16V	C509, 514	271454
4700UF 25V	C510	240241

**CM-14
SECTION**

CM 14 COLOUR MONITOR

ELECTRICAL ADJUSTMENTS

1. BEFORE MAKING ELECTRICAL ADJUSTMENTS

Read and perform these adjustments when repairing the circuits or replacing electrical parts.

CAUTION

Use an isolation transformer when performing any service on this chassis.

Before removing the anode cap, discharge electricity because it contains high voltage.

When removing a PCB or related component, after unfastening or changing wire, be sure to put wire back in its original position.

1-1: Prepare the following measurement tools for electrical adjustments.

1. Oscilloscope
2. Frequency Counter
3. White Balance Signal Generator
4. White Balance Checker
5. DC Voltmeter

2. BASIC ADJUSTMENTS

2-1: +5V

1. Load 2.4A into DC out.
2. Connect the DC voltmeter to DC out.
3. Adjust VR501 until voltage is $4.8 \pm 0.03V$.
4. After adjustments, verify if the voltage is less than 5.25V in no-load mode.

2-2: H-HOLD

1. Shut off the input signal and set the screen to the free-run condition.
2. Connect a frequency counter to CRT heater.
3. Adjust VR403 to obtain 15.625KHz reading.

2-3: CUT OFF

1. Shut off the input signal and set the screen to the free-run condition.
2. Set the bright control to maximum position.
3. Set VR801, VR803, VR804 and VR805 to center positions.
4. Connect the oscilloscope to collector of Q802.
5. Adjust VR402 to obtain 125V as shown in Fig. 2-1.
6. Then, short the first pin and the second pin in CP402.
7. Keeping the condition, adjust the horizontal line on the picture to a extent of lighting faintly.

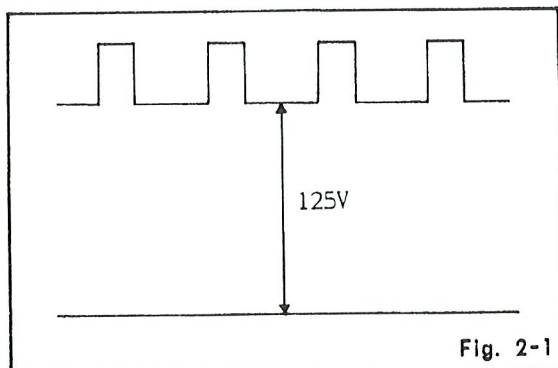

Fig. 2-1

2-4: SUB BRIGHT

1. Shut off the input signal and set the screen to the free-run condition.
2. Set the bright control to maximum position.
3. Connect the oscilloscope to collector of Q802.
4. Adjust VR402 to obtain 123 ~ 124V as show in Fig. 2-2.

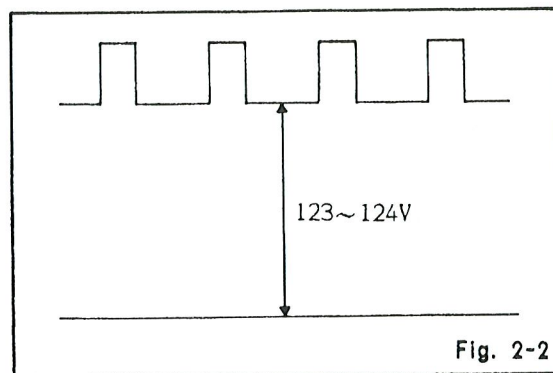

Fig. 2-2

2-5: WHITE BALANCE

1. Input 75% white and 25% white patterns to the monitor with the white balance signal generator.
2. Set the SW1 of the white balance signal generator to auto position. Adjust high control of the white balance signal generator until green of the white balance checker is centered for 75% white. Adjust low control until green is centered for 25% white.
3. Adjust VR802 and VR805 until blue of white balance checker is centered. Adjust VR801 and VR803 until red of white balance checker is also centered.

2-6: V.SIZE

1. Set the bright control to maximum position.
2. Receive the monochrome pattern.
3. Adjust VR406 to $AB = CD$ as shown in Fig. 2-3.

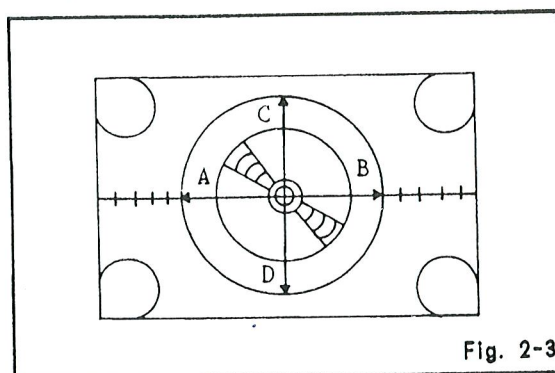

Fig. 2-3

2-7: FOCUS

1. Set the bright control to maximum position.
2. Adjust the picture by using focus volume.

3. PURITY AND CONVERGENCE ADJUSTMENT

NOTE

1. Turn the unit on and let it warm up for at least 30 minutes before performing the following adjustments.
2. Place the CRT surface facing east or west to reduce the terrestrial magnetism.
3. Turn ON the unit and demagnetize with a Degauss Coil.

3-1: STATIC CONVERGENCE (ROUGH ADJUSTMENT)

1. Tighten the screw for the magnet. Refer to the adjusted CRT for the position. (Refer to Fig. 3-1)
If the deflection yoke and magnet are in one body, untighten the screw for the body.
2. Receive the green raster pattern from color bar generator.
3. Slide the deflection yoke until it touches the funnel side of the CRT.
4. Adjust center of screen to green, with red and blue on the sides, using the pair of purity magnets.
5. Switch the color bar generator from the green raster pattern to the crosshatch pattern.
6. Combine red and blue of the 3 color crosshatch pattern on the center of the screen by adjusting the pair of 4 pole magnets.
7. Combine red/blue (magenta) and green by adjusting the pair of 6 pole magnets.
8. Adjust the crosshatch pattern to change to white by repeating steps 6 and 7.

3-2: PURITY

NOTE

Adjust after performing adjustments in section 3-1.

1. Receive the green raster pattern from color bar generator.
2. Adjust the pair of purity magnets to center the color on the screen.
Adjust the pair of purity magnets so the color at ends are equally wide.
3. Move the deflection yoke backward (To neck side) slowly, and stop it at the position when the whole screen is green.
4. Confirm red and blue colors.
5. Adjust the slant of the deflection yoke while watching the screen, then tighten the fixing screw.

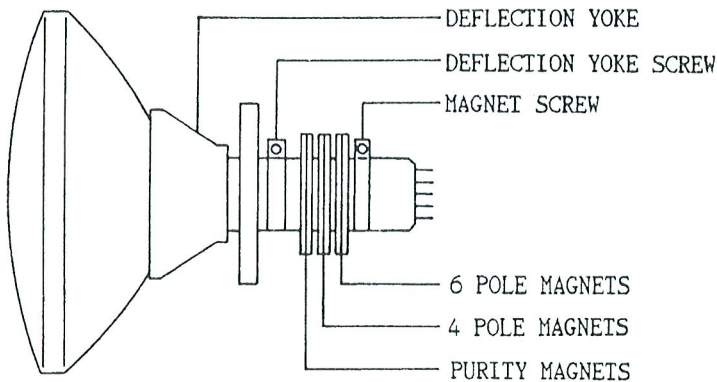

Fig. 3-1

3-3: STATIC CONVERGENCE

NOTE

Adjust after performing adjustments in section 3-2.

1. Receive the crosshatch pattern from color bar generator.
2. Combine red and blue of the 3 color crosshatch pattern on the center of the screen by adjusting the pair of 4 pole magnets.
3. Combine red/blue (magenta) and green by adjusting the pair of 6 pole magnets.

3-4: DYNAMIC CONVERGENCE

NOTE

Adjust after performing adjustments in section 3-3.

1. Adjust the differences around the screen by moving the deflection yoke upward/downward and right/left. (Refer to Fig. 3-2-a)
2. Insert three wedges between the deflection yoke and CRT funnel to fix the deflection yoke. (Refer to Fig. 3-2-b)

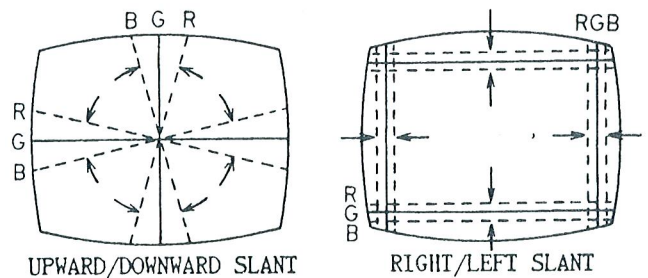
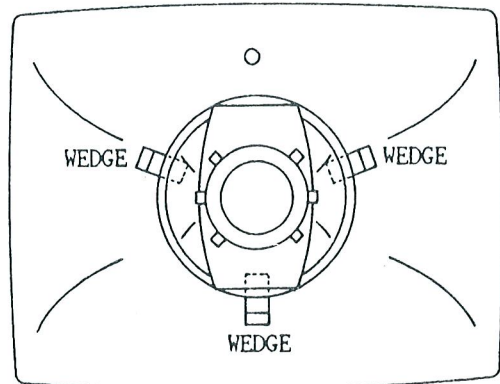

Fig. 3-2-a



WEDGE POSITION

Fig. 3-2-b

MAJOR COMPONENTS LOCATION GUIDE

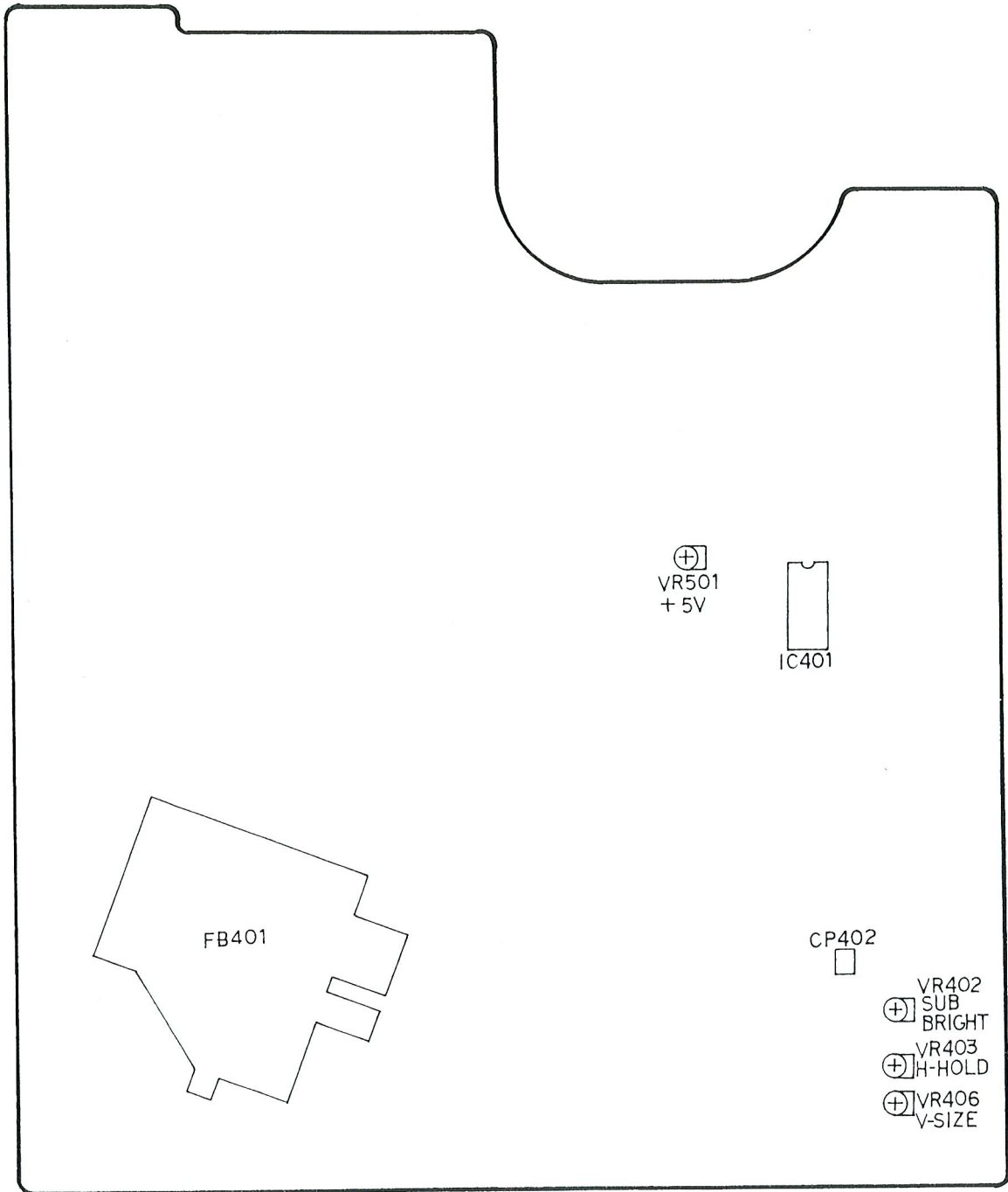

MAIN P.C.BOARD

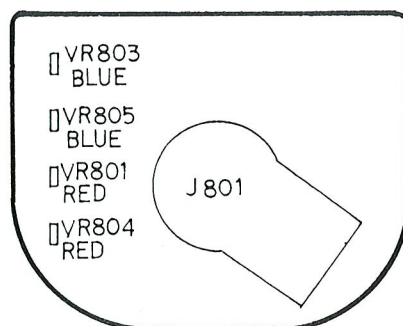

CRT P.C.BOARD

CM14 ELECTRICAL PARTS LIST

Ref. No.	Description	Part No.
IC's		
IC301	IC LA635S	240015
IC351	IC LA4445	271162
IC401	IC LA7800	1400106
IC402	IC LA7830	170444
IC501	IC STK73410	271151
IC502	IC L78 MG-OEC	170446
Transistors		
Q401, 402, 506	TR 2SC1815Y, Silicon	170447
Q403	TR 2SA950Y, Silicon	170448
Q404	TR 2SC2271-AE, Silicon	1409202
Q405	TR 2SD1877, Silicon	271152
Q502	TR SD1667, Silicon	177045
Q503, 505	TR 2SA1015Y, Silicon	170453
Q504	TR 2SC2120Y, Silicon	170113
Q801-803	TR 2SC3417, Silicon	271181
Diodes		
D101-103	D GZA6.2 Y BT Zener	171552
D104-106	D GZA6.8 Y BT Zener	175636
D401, 410	D 1S2472T-77, Silicon	170455
D402	D GZA11 Y BT Zener	810339
D405, 406, 408	D 10ELS6TA1 Rectifier	171550
D407, 505	D DFD05TG-BT Rectifier	171490
D411	D 11E1TA1 Silicon	171050
D501-504	D 20E10FA13 Silicon	176039
D506, 507	D 15DF6-FC Silicon	271180
D508, 509	D 30DF2-FC Silicon	171555
D510	D R2M-LFB3 Avalanche	1400122
Coils		
L401	Coil Linearity	271186
L501	Coil Line Filter AC	171502
L502	Coil Degauss	271187
L801	Coil 100UH	175867
Switches		
SW501	Switch Push ESB-90217S	171511
PCB's		
PCB001	PCB ASS'Y MM0052-C	
PCB002	PCB ASS'Y MS0191	
Miscellaneous		
T401	Trans. Horiz. Drive 305Y001	171506
T501	Trans. Switching 8139012	271188
J801	Socket CRT HPS1171-01-050	171514
F501	Fuse Bet 2A(T) 250V	193357
FB401	Trans. Flyback 3714016	271189
FH501	Holder Fuse H0451	271429
FH502	Holder Fuse H0452	271430
ICP401	IC Protector ICP-N50	171547
ICP501	IC Protector ICP-N20T104	150442
ICP502	IC Protector ICP-N38T104	271157
ICP503	IC Protector ICP-N75T104	171057
SP301, 302	Speaker S08J60	271169
TH501	Degauss Element ERP-F5B0M180K	171533
V001	CRT 370KRB22-TC21 (SPYB)	271190
CD101	Cord DIN (7 pin)	271176
CD502	Cord DC 6.5 mm	271177

Ref. No.	Description	Part No.
Variable Resistors		
VR301	VROT EVJ-C00F25A24	271403
VR401	VROT EVU-E2AF25B52	271182
VR402, 403, 407	VRSF EVNDXAA02B03	271183
VR405	VROT RK09K1110APQA	271184
VR406, 501	VRSF EVNDXAA02B13	271185
VR801	VRSF 5K OHM Red	171696
VR802	VRSF 5K OHM Green	171697
VR803	VRSF 5K OHM Blue	171698
VR804	VRSF 500 OHM Red	171699
VR805	VRSF 500 OHM Blue	171700
Resistors: Carbon 1/6W		
39K OHM	R309, 310	152201
Resistors: Carbon 1/4W		
100 OHM	R101-103, 810	240507
180 OHM	R415, 807	193588
220 OHM	R357, 358, 407, 416	193589
270 OHM	R811, 814	193590
330 OHM	R401, 404	193591
1K OHM	R353, 354, 411, 423, 432, 453, 504, 512, 514-517, 815, 816	193594
1.5K OHM	R420, 421, 441	271439
1.8K OHM	R402, 403, 442, 462	271202
2.2K OHM	R410	193595
2.7K OHM	R104-106, 351, 352, 817	193596
3.3K OHM	R406	193597
8.2K OHM	R418, 419	271203
10K OHM	R428, 429	240511
12K OHM	R409, 424	10087
15K OHM	R431	271442
22K OHM	R305-308, 414	193701
27K OHM	R425	193702
33K OHM	R440	10097
47K OHM	R301-304, 412	240512
56K OHM	R417	10103
82K OHM	R439, 463	271204
120K OHM	R430	271205
150K OHM	R451	271206
180K OHM	R408	271207
220K OHM	R413	193706
Resistors: Carbon 1/2W		
1.5 OHM	R449	271208
15 OHM	R355, 356	271432
220 OHM	R433	271209
470 OHM	R445	201711
1K OHM	R513	240214
2.2K OHM	R446, 460	271210
2.7K OHM	R802-804	176749
4.7K OHM	R426	176750
120K OHM	R502	271211
270K OHM	R503	271212
1M OHM	R801	271213
Resistors: Cement		
5.6 OHM 5W	R501	271214
15 OHM 7W	R436	170417
Resistors: Fuseable		
3.3 OHM 1/2W	R438	170138
8.2 OHM 1/4W	R444	271215
Resistors: Metal Oxide		
0.33 OHM 1W	R510, 511	271444
2.2 OHM 3W	R508	271216
3.9 OHM 2W	R518	271217
15 OHM 2W	R509	271218
22 OHM 2W	R433	271249
22 OHM 3W	R505	271219
33 OHM 3W	R506, 507	271220
82 OHM 2W	R519	271221
1K OHM 1W	R452	271222
3.9K OHM 2W	R427	271223
15K OHM 2W	R805, 808, 812	271224

CM14 ELECTRICAL PARTS LIST

Ref. No.	Description	Part No.
Capacitors: Ceramic		
22PF	C416	271236
100PF 500V	C403, 441	271237
220PF	C806	157575
220PF 500V	C423	174811
240PF	C804, 807, 808	271238
270PF	C305, 306	157677
270PF 500V	C433	271239
330PF	C803	240233
470PF 2KV	C510	176751
560PF 500V	C417	271240
680PF	C802	806223
1000PF 2KV	C801	271241
1000PF 500V	C512, 513	271242
1500PF 2KV	C432	271243
2200PF 2KV	C502-504	174812
2200PF 125V	C506	271244
0.0015UF 2KV	C511	271245
0.0022UF 2KV	C509	271246
Capacitors: Plastic		
0.0056UF	C415	174818
Capacitors: Metal Polypropylene		
0.0082UF 1600V	C431	271247
0.1UF AC250V	C501	171609
0.82UF 200V	C429	271248
Capacitors: Tantalum		
1UF 16V	C411	271234
2.2UF 16V	C426	271235
Capacitors: Polyester		
0.001UF 50V	C303, 304, 401	240250
0.0015UF 50V	C408	271230
0.0047UF 50V	C421	271231
0.01UF 50V	C413, 427	250419
0.015UF 50V	C409	152389
0.039UF 50V	C404	177154
0.047UF 50V	C406, 446	251526
0.056UF 50V	C365, 366	157546
0.068UF 50V	C410, 428	271232
0.1UF 50V	C361, 362	250066
0.15UF 100V	C422	271233
Capacitors: Electrolytic		
1UF 50V	C307, 308, 414, 508	157563
1UF 160V	C419, 445	271225
2.2UF 50V	C440, 444	157672
4.7UF 50V	C301, 302, 407, 420	157565
10UF 16V	C519	157581
10UF 25V	C517	271452
10UF 50V	C353, 354	240462
10UF 100V	C507	271226
22UF 250V	C430	170419
47UF 16V	C351, 352, 418	172074
100UF 16V	C357, 358	157568
100UF 25V	C309	157569
100UF 35V	C425	157570
150UF 400V	C505	157792
220UF 25V	C355	152565
220UF 160V	C514	170851
470UF 16V	C405	157630
470UF 25V	C356	271227
470UF 35V	C515	150919
1000UF 10V	C518	271228
1000UF 16V	C359, 360	271453
1000UF 25V	C516	152567
1000UF 35V	C402	271229
2200UF 25V	C424	157653

CM-14 MONITOR / CRT P.C.B. Component Layout

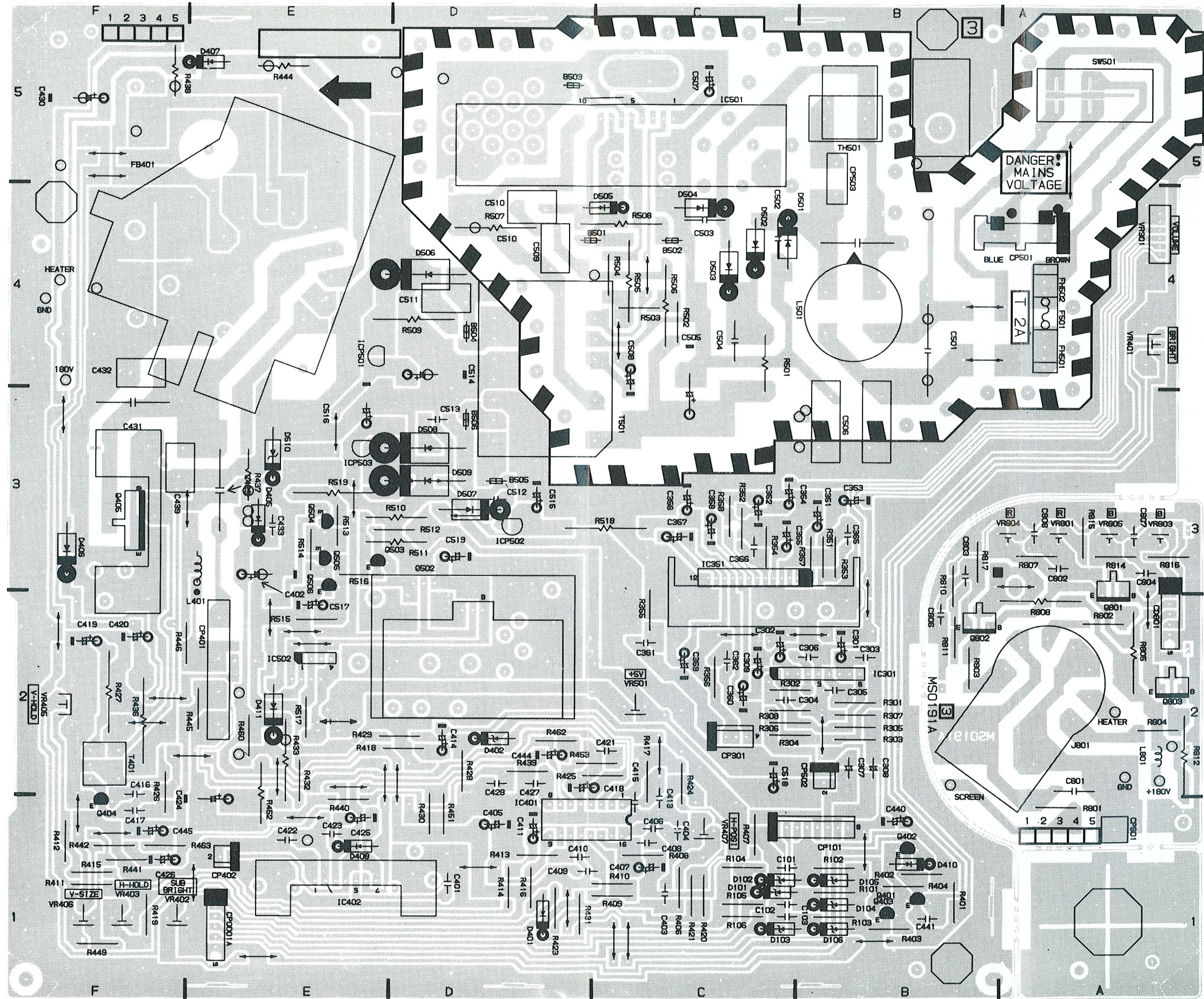

CM-14 POWER / SOUND SCHEMATIC DIAGRAM

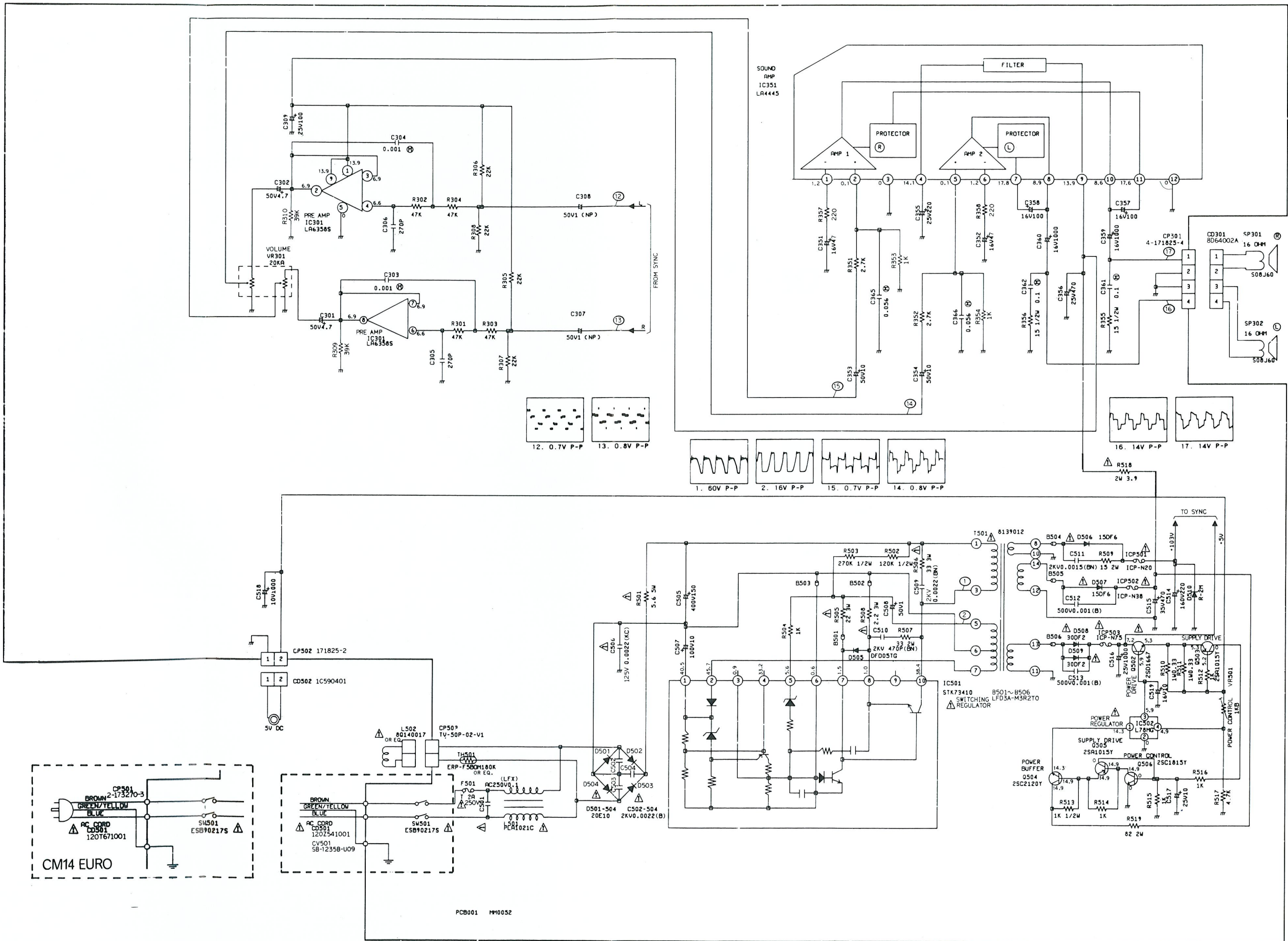

CM-14 MONITOR SCHEMATIC DIAGRAM

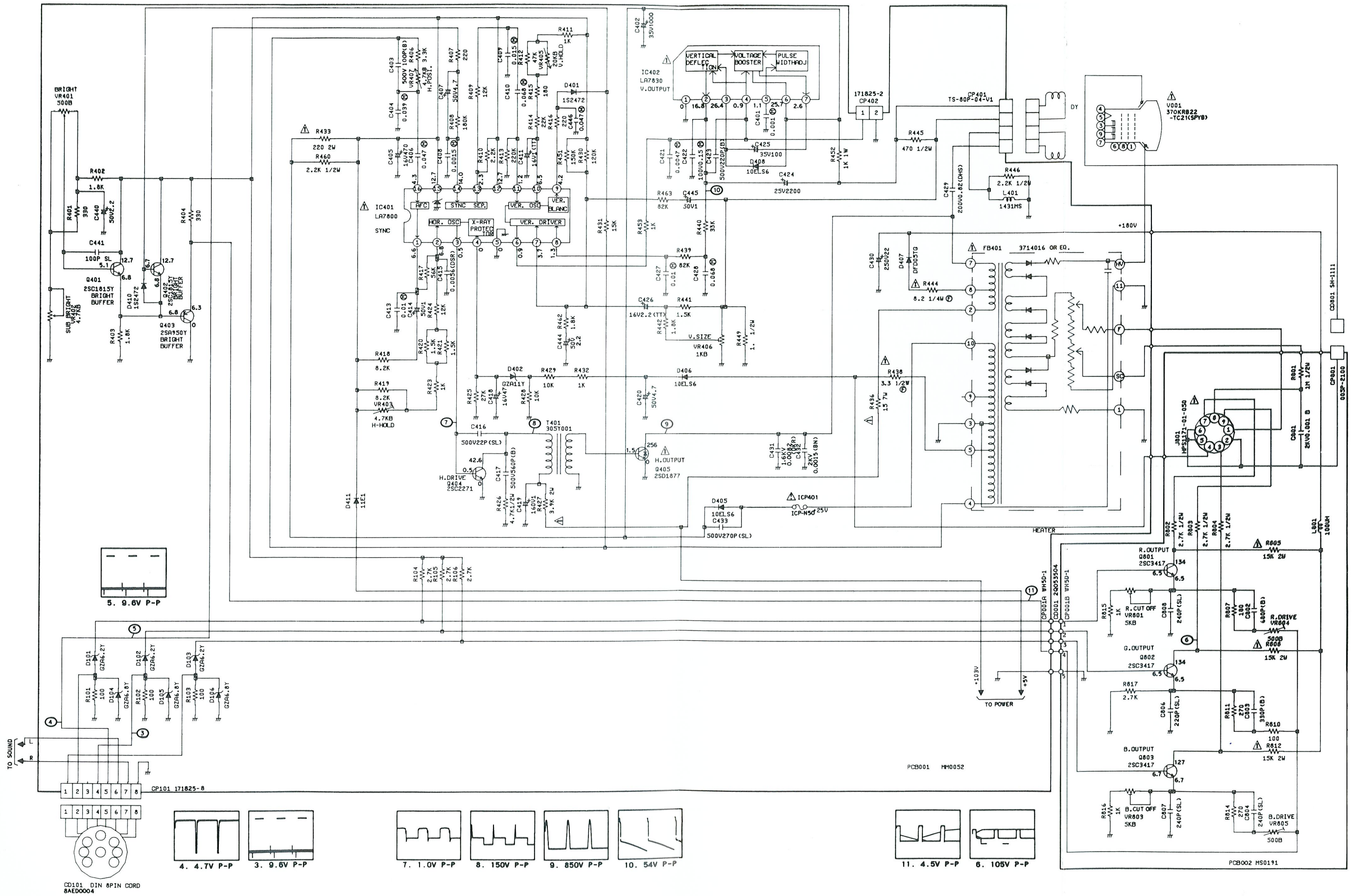

CM-14 CABINET EXPLODED VIEW

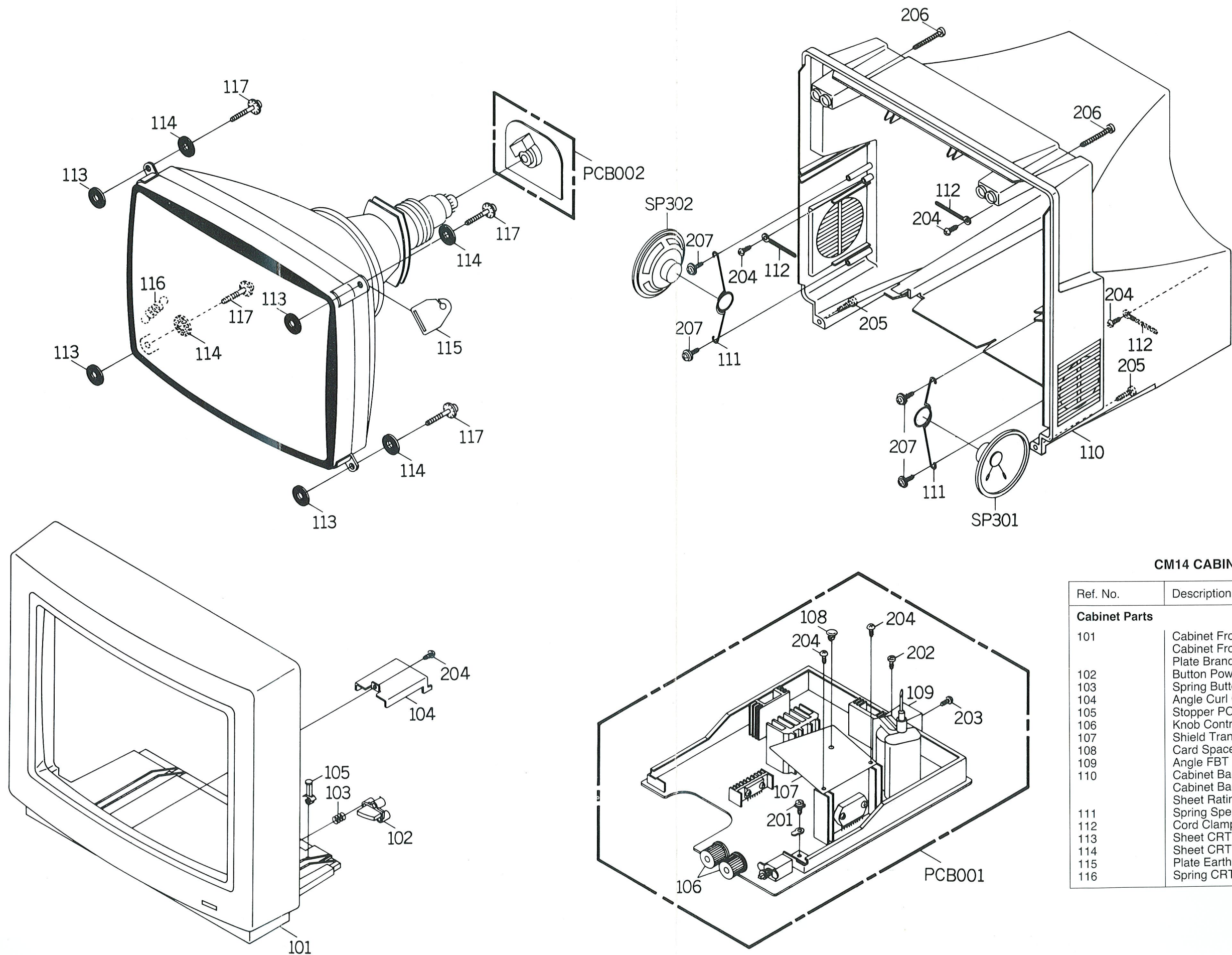

CM14 CABINET PARTS LIST

Ref. No.	Description	Part No.
Cabinet Parts		
101	Cabinet Front Ass'y	271155
	Cabinet Front	
	Plate Brand	
102	Button Power	271413
103	Spring Button (B)	271414
104	Angle Curl Cord	271415
105	Stopper PCB	271191
106	Knob Control	271175
107	Shield Trans	271192
108	Card Spacer KGPS8R	271193
109	Angle FBT	
110	Cabinet Back Ass'y	271156
	Cabinet Back	
	Sheet Rating	
111	Spring Speaker	271197
112	Cord Clamp No. PEC-034-0	
113	Sheet CRT Support	
114	Sheet CRT Support	
115	Plate Earth Wire	
116	Spring CRT Earth	