

≡ **chroma ~ chime** ≡

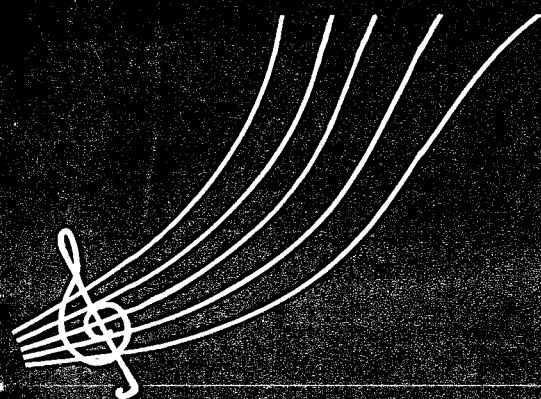

KIT
assembly
manual

CHROMATRONICS

Coachworks House, River Way, Harlow, Essex.
Telephone: Harlow (0279) 418612.

CHROMATRONICS

Coachworks House, River Way, Harlow,
Essex.
Telephone: Harlow (0279) 418612.

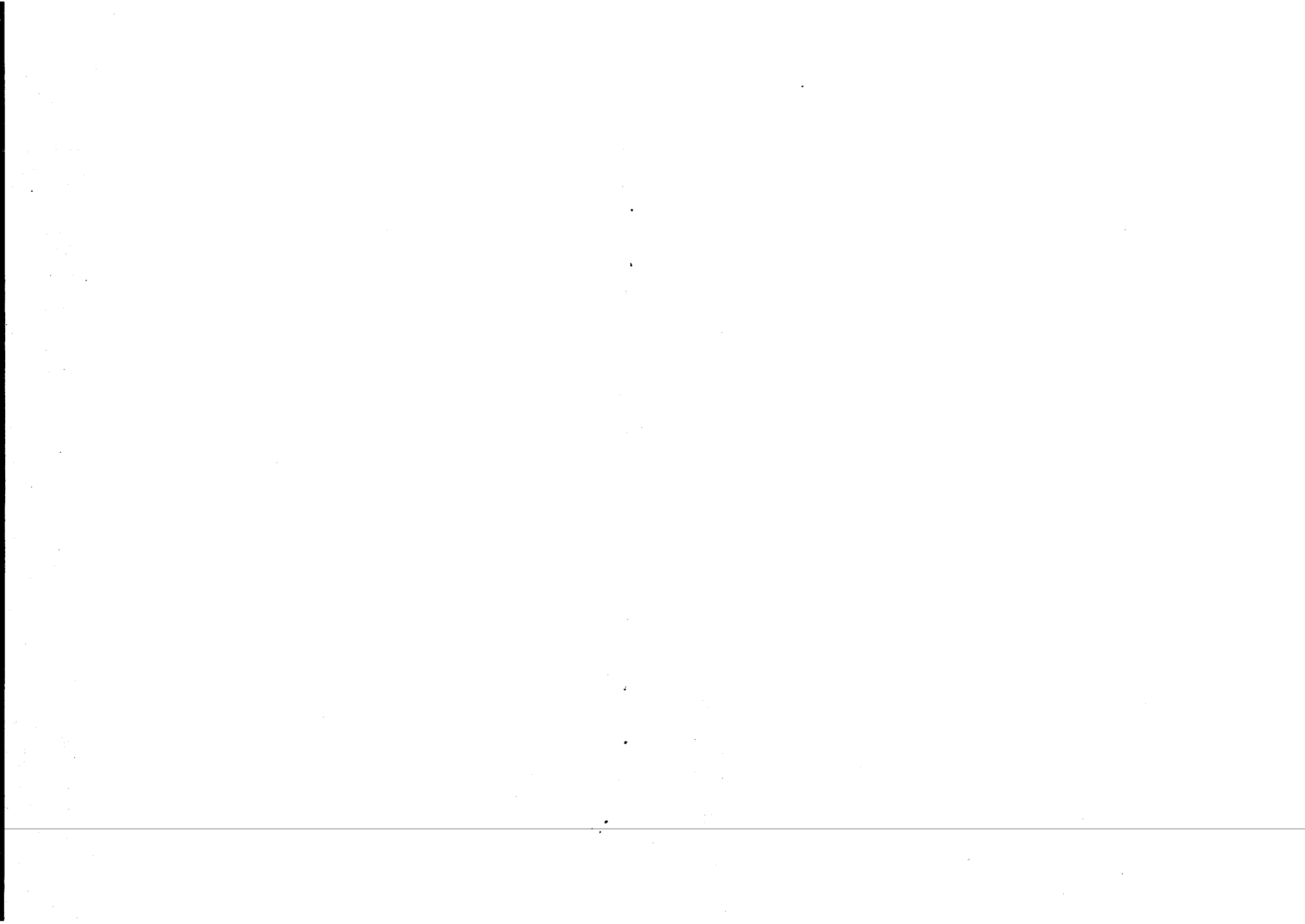

combination with R2 and RV2, the timbre pot. Just before the commencement of each note the output O1 (Pin 16) is turned on momentarily causing the base of TR2 to be driven hard on. TR2 then discharges C2 completely so that the first few cycles of each note is always at peak amplitude. As the note is prolonged, C2 gradually charges up via R2 and RV2 causing the negative excursions at the base of TR2 to get higher and higher. This, in fact, leads to an exponential decay in the peak to peak voltage at this point.

RV3 operates as a volume control by reducing the audio voltage at the emitter of TR3 which is applied to the base of TR4. The output driver TR4, is a medium power device which directly drives the loud speaker SP1 via R7 a current limiting resistor. The diode, D2, prevents the base of TR3 from being pulled down during the discharge period of C2. This avoids any objectionable clicks which might be heard in between the notes as they are played in sequence.

Tune Speed Control

The overall playing time for the tune and the timing of each individual note is determined by an independent means from the master clock oscillator to the mpu. For each note, R9 output (Pin 2) from the mpu is turned on and off momentarily sufficiently to cause the saturation of TR1 and hence discharge C1. C1 then proceeds to re-charge via the speed control RV1 and R1. The voltage at the junction of RV1 and C1 and the K8 input (Pin 8) to the mpu gradually drops until the mpu senses the low level input at K8. R9 is then turned on again to repeat the cycle which may be performed up to sixteen times for each individual note. Short notes may only be given two counts in this manner, longer note progressively more. Hence the overall timing for the tune is entirely determined by the time constant of C1 with RV1.

CHROMA-CHIME KIT ASSEMBLY MANUAL

CONTENTS

| Page | |
|-------------|----------------------------------|
| 3 | Introduction |
| 4 | Assembly Method |
| 4 | Parts List |
| 6 | Soldering Hints |
| 8 | Printed Circuit Assembly |
| 15 | Printed Circuit Assembly Drawing |
| 17 | Final Assembly |
| 19 | Testing |
| 20 | Returns & Servicing |
| 21 | Circuit Description |
| 22 | Circuit Diagram |

Copyright Chromatronics 1977

via R10. TR5 immediately saturates causing the negative rail to be effectively connected to the mpu and subsidiary circuitry. When this happens the mpu automatically initialises itself resetting all its internal registers and logic etc. The clock oscillator built in to the IC also starts up, the frequency being determined by the RC time constant R6 and C3. This is arranged to be nominally 400KHz. The wave form at the junction of pins 18 and 19 and R6 and C3 is a negative going sawtooth of approximately 3 volts amplitude peak to peak. Having initialised the mpu, after a short delay, turns on the output at R10 (Pin 3) high, causing the base of TR5 to be biased via R8. This then maintains the circuit in a powered condition even if the push-button contact is released.

Tune Selection

Once the output at R10 has been turned on the mpu proceeds to turn on each of the outputs R0 to R7 alternately in succession. Each time an output is turned on the inputs to the device at K1, K2 and K4 (Pins 5, 6 and 7) are tested to see if a direct connection exists due to the positions of the two selector switches S1 and S2. In this way it is possible to test for one of 24 unique positions of the two switches; one for each of the 24 tunes. If for some reason there should not be a direct connection between one of the R0 to R7 outputs and the K inputs and mpu will continue to sequence these in succession, repeating the cycle once every approximately 5mS until a connection is made. (This would normally only occur if one of the switches was faulty or possibly left in an intermediate position). Should the secondary push-button connected between the external terminals 3 and 4, the system will be started up by the current passing through D4 and R10 and biasing TR5. The high voltage at terminal 3 will also cause the K4 input connected via R11 and D3 to be forced high. Thus, in the start up selection sequence only the tune normally associated with the R0/K4 connection will be played giving the opportunity for the second button to be used to indicate a caller at a different door to the house with a different tune than that for the primary push button on terminals 1 and 2.

Audio Processing and Output

The audio output from the mpu is provided at pin 10 (07). This takes the form of an audio frequency square wave ranging between 200-550Hz, depending on which note is being played. The diode, D1, allows the output darlington pair, TR3 and TR4, to be held cut off during the positive excursions of the 07 output. On the negative excursions from 07, the voltage at the base of TR3 is pulled down by R3. This level is set by the charge in C2 which generates the output decay function in

Fig. 19

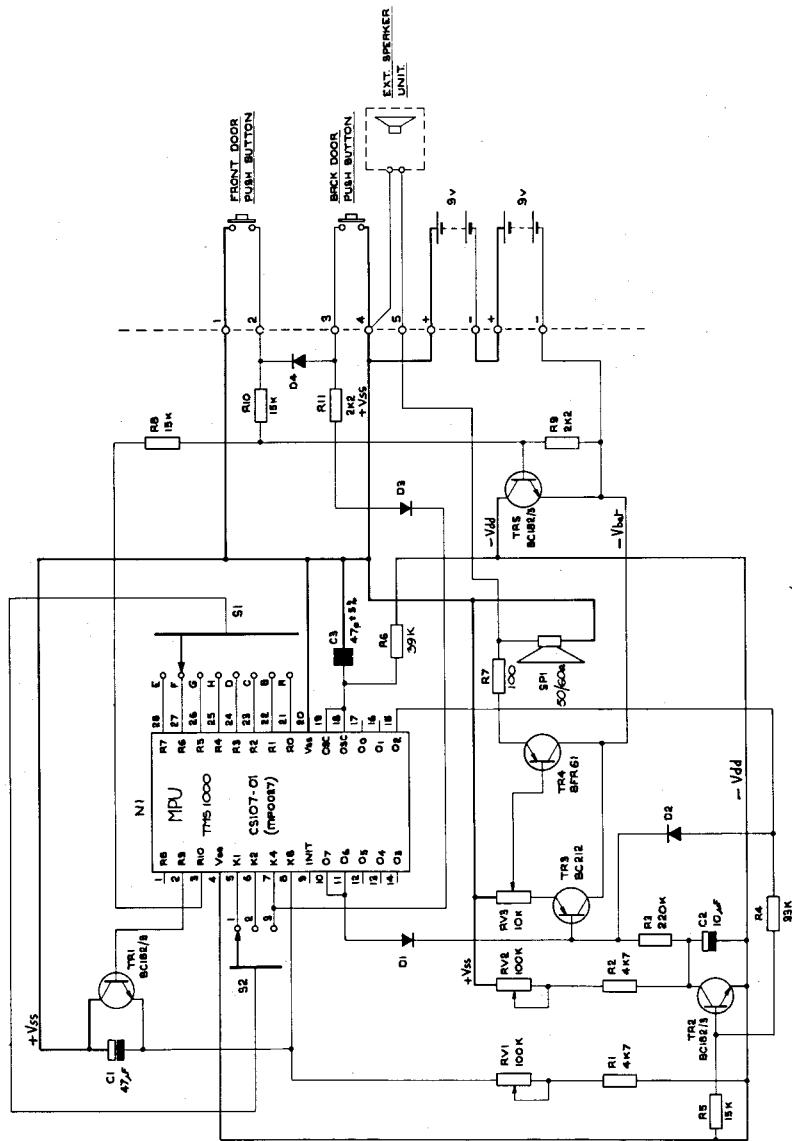

"CHROMA-CHIME" KIT MANUAL

Introduction

The "Chroma-Chime" Kit has been specially prepared in such a way that anyone possessing a little experience of electronics assembly and soldering will have complete success. With just a little care and patience in first reading this kit manual from cover to cover before starting construction, and then by observing that the construction procedures are followed, you will be assured of certain success. Having built the "Chroma-Chime", you should be able to take pride not only in your work, but in the ownership of the world's first microprocessor driven electronic door chime!

Getting Started

First unpack all the components for your kit and check them off against the parts list. Make sure that you do correctly identify each one listed, as mistakes may be difficult to trace later.

WARNING: The MOS Microprocessor integrated circuit should be left in its protective packing until immediately required for assembly. This device could be susceptible to damage due to stray static electricity if handled carelessly. Although it is internally protected against such damage, under normal circumstances, it is not wise to take unnecessary risks with such an expensive component!

The components for the "Chroma-Chime" kit are packed as follows:—

- Pack 1 — 11 resistors
- Pack 2 — 4 diodes, 5 transistors, and 3 capacitors
- Pack 3 — MOS microprocessor integrated circuit
- Pack 4 — Loudspeaker
- Pack 5 — Assorted hardware, wire and solder
- Loose Packed Printed circuit board, SRBP base cover, plastic cabinet parts, operating instructions.

All the components for the "Chroma-Chime" kit are itemized in the parts list against cross reference part numbers to the printed legend on the component side of the PCB (printed circuit board) and also the circuit diagram. The part numbers will enable you to correctly identify the location of each electrical component in the assembly. The item numbers given in the parts list will enable you to identify the parts in the final mechanical assembly.

Assembly Method

Unless care is taken to follow the methodical manner layed down in the step-by-step instructions, it is quite likely that you might be disappointed by the failure of the unit to operate properly.

The assembly instructions divide the work up into groupings of like components in a progressive sequence. As each numbered part is assembled, it should be ticked off of the parts list. Likewise, as each step is completed, that too should be ticked off the procedure. By using the step-by-step instructions with the parts list, hopefully you will not overlook anything or make any errors.

Tools

You will need the following tools to assemble your kit:—

Side cutters

Long nosed pliers

Small screwdriver

Wire strippers

Small Philips screwdriver

Light soldering iron 10–30 watts (or temperature controlled) with a small bit less than 1/8" (3mm) at the tip.

NOTE: An electric bell or buzzer must **never** be used to make a continuity check on the printed circuit board. Such devices generate very high voltages which would undoubtedly damage the semiconductors on the PCB. A multimeter set on the lowest ohms range is ideal for this purpose, should it be required.

Parts List for "Chroma-Chime" Kit

| | Spare Part Price Each |
|--|--------------------------|
| N1 — Texas Instruments TMS1000 micro-computer integrated circuit CS107–01/MP0027 | £8.00 |
| 28 Pin dual-in-line socket for use with N1 | 45p |
| Transistors: | |
| TR1 — NPN BC172, BC182, BC183, SX4061 | 20p |
| TR2 — NPN BC172, BC182, BC183, SX4061 | 20p |
| TR3 — PNP BC212, ZTX212, BC205, SX3708 | 20p |
| TR4 — PNP (Power) BFR61/BC327 | 25p |
| TR5 — NPN BC172, BC182, BC183, SX4061 | 20p |

When sending a complete unit back through the post, you must pack it very securely, preferably in the original materials supplied. Always check that you have included your name and address and the reason for the return. Cheques or Postal Orders to be made payable to Chromatronics. Address any communications or return for servicing, or order for spare parts to:—

**CHROMATRONICS
SERVICE DEPARTMENT
COACHWORKS HOUSE
RIVER WAY
HARLOW
ESSEX.**

Circuit Description

This electronic door chime circuit is driven principally by a dedicated micro-computer chip, the CS107/01. This device is capable of the control and timing necessary to generate a number of different tunes emitted by the unit's loud speaker. Since all the notes necessary to produce the tunes are generated by counting down from the master clock oscillator, they are all given precise digital relationships and therefore cannot go out of tune relative to each other.

Power Supply

The system is powered by two nominal 9 volt batteries connected in series giving 18 volts total output. Since the CS107/01 mpu is fabricated by a P-channel process, it is convenient to regard the positive rail from the battery as the COMMON. Connected to the negative supply rail are three transistors, TR3, TR4 and TR5. In the quiescent state neither of these devices conduct appreciably at all. This is because TR5's base is not biased via the R10 output of the mpu (Pin 3) via R8. Thus, the potential of the collector of TR5 may be regarded as being 'high', thus TR3 and TR4 are incapable of being biased sufficiently to turn them on. Apart from TR3 and TR4 all the other subsidiary circuitry, including the negative input to the mpu, are all connected to the collector of TR5 holding them off in the quiescent state. At normal room temperatures, the total current drawn from the batteries, at room temperature, is less than 0.1uA.

Initialisation

When the push button connected between the external terminals 1 and 2 is depressed and the contact made, the base of TR5 is biased by current

- (C) **If the unit fails:**
It plays seemingly random notes, the batteries are probably either worn out or shop soiled. Alternatively, there could be a fault in the area of TR5, R9, R8.
- (D) **If the unit just makes a click sound:**
Check C3 and R6, TR2 and TR4 and all the associated components.
- (E) **If the unit makes a continuous note:**
Check TR1 C1, RV1 and R1
- (F) Now check the operation of each of the three controls 'V' volume, 'S' speed or tempo and 'T' the tone. Any fault here should be obvious.
- (G) As before, short out terminals 1 and 2. This time, the unit should respond by playing tune B1, God Save the Queen.
- (H) **No sound at all:**
Check selector switches and contacts for correct assembly, etc. If it plays the wrong tune, check for short circuits between the IC pins going to S1 contacts.
- (J) Go round and check each of the tunes for the remaining positions of S1, i.e. C1, D1, E1, F1, G1, H1 and A1. Then go round once again, having re-selected the second selector switch to position 2, and check the next eight tunes. If this does not work, then there must be an open circuit between pin 6 of the IC and the contact for position 2. Lastly, re-select S2 for position 3 and go round all the positions of S1 checking each of the tunes as before. If this does not work, then there must be an open circuit between pin 7 and the IC and the contact for position 3. All being well, you can now snap into position the SRBP back cover to the unit and then proceed with the installation as described in the operating instructions.

Servicing and Spare Parts

If you find that you are unable to get your "Chroma-Chime" Kit working properly, the Chromatronics Service Department will be able to do this for you. The fixed service charge for the "Chroma-Chime" Kit is £4.00 inclusive of VAT and postage and packing. Should it be found that the reason why your kit failed to operate was due to a faulty component, this fee will be returned to you with your corrected unit. However, since all micro-computer IC's are individually checked and tested before despatch, we cannot accept liability for any failed devices. Should we discover that to be the reason why a kit failed to work, once returned to us, we would unfortunately have to charge a further £4.00 to cover the cost of a replacement device.

Diodes

D1, D2, D3 and D4 — All 1N4148 YELLOW, BROWN, YELLOW, GREY 7p

Colour Coding

Resistors

| | | | | | |
|-----|------|--------|--------|--------|----------------|
| R1 | 4K7 | YELLOW | MAUVE | RED | GOLD |
| R2 | 2K2 | RED | RED | RED | GOLD |
| R3 | 220K | RED | RED | YELLOW | GOLD |
| R4 | 33K | ORANGE | ORANGE | ORANGE | GOLD |
| R5 | 15K | BROWN | GREEN | ORANGE | GOLD |
| R6* | 39K | ORANGE | WHITE | ORANGE | GOLD |
| R7 | 100 | BROWN | BLACK | BROWN | GOLD or SILVER |
| R8 | 15K | BROWN | GREEN | ORANGE | GOLD |
| R9 | 2K2 | RED | RED | RED | GOLD |
| R10 | 15K | BROWN | GREEN | ORANGE | GOLD |

All resistors 2p each

*R6 may be alternatively supplied as 33K, ORANGE, ORANGE, ORANGE

Capacitors

| | | | |
|----|------|----------------------|-----|
| C1 | 47uF | Electrolytic | 12p |
| C2 | 10uF | Electrolytic | 10p |
| C3 | 47pF | Ceramic or Polyester | 10p |

Potentiometers:

| | | | |
|-----|------|--------------|-----|
| RV1 | 100K | Skeleton Pot | 15p |
| RV2 | 100K | Skeleton Pot | 15p |
| RV3 | 10K | Skeleton Pot | 15p |

Loudspeaker:

| | | | |
|-----|---------------|-----|------|
| SP1 | 50 to 90 ohms | 2¼" | 100p |
|-----|---------------|-----|------|

Hardware:

| Item No. | Qty | Part | Price Per Set |
|----------|-----|-----------------------------|---------------|
| 1 | 1 | CS107 Printed Circuit Board | 175p |
| 2 | 4 | Battery Contacts | 40p |
| 3 | 2 | 4" loudspeaker wires | 1p |
| 4 | 1 | Plastic Case | 200p |
| 5 | 2 | Plastic Access covers | 50p |
| 6 | 2 | Selector Knobs | 30p |
| 7 | 2 | Selector Contacts | 30p |

| | | | |
|----|---|-----------------------|-----|
| 8 | 3 | Control Shafts | 15p |
| 9 | 1 | SRBP Base Cover | 40p |
| 10 | 1 | Facia Label Left | 10p |
| 11 | 1 | Facia Label Right | 10p |
| 12 | 1 | Tune Label | 5p |
| 13 | 1 | Battery Label | 5p |
| 14 | 5 | Long self-tap screws | 2p |
| 15 | 3 | Short self-tap screws | 1p |
| 16 | 2 | Wood screws | 2p |
| 17 | 3 | "Starlok" washers | 2p |
| 18 | 5 | Plain Washers | 2p |
| 19 | 3 | Rubber Washers | 3p |
| 20 | 1 | Kit Manual | 75p |

All prices inclusive of V.A.T. and correct at time of going to press (June 1977). When spare parts are ordered, 25p must be added to the pre-paid amount in order to cover handling, postage and packing. Component types and/or values not shown on the "Chroma-Chime" parts list cannot be supplied.

In the event of a faulty part being found, we will undertake to replace it free of charge. However, this is very unlikely as all parts are pre-checked prior to despatch. Claims for faulty micro-computer integrated circuits cannot be entertained should any IC pins be damaged or touched with a soldering iron.

Soldering Hints

Poor workmanship when soldering is the most frequent cause for electronic kits, such as your "Chroma-Chime", not working first time. So, it is important that you do use the right technique during construction.

When assembling the parts on the printed circuit board, make sure each is seated down square on the surface, always taking care not to exert unnecessary strain on their leads. As each component is pushed home, bend the leads upwards on the track side at about 45°, as shown in Fig. 1. This will retain them in place prior to cropping and soldering. Always double check to make sure the components are in the right positions before soldering.

Having cropped the lead of the components to about 1/10" (2-3mm) from the track surface, (Fig. 2), place the PCB track side up, ideally in an assembly stand or on a sponge mat. A couple of books could do as well. Soldering can now commence.

The tip of the soldering iron should always be wiped on a wet sponge

The PCB is secured into the case by the three small self tapping screws adjacent to RV2, RV3 and C2 (Fig. 18). These should be done up fairly tightly, but not using an excessive force, which might otherwise strip the plastic thread. Likewise, the five terminal screws, complete with their washers, can now be screwed in from the battery compartment side of the unit.

The three control knobs which operate RV1, RV2 and RV3, are simply pushed into position from the control panel compartment side, having located their cross pegs in the respective cross shaped holes. Do not use too much force putting these in or you might otherwise break one of the pots.

Step 15 – Labels

Before applying the two decorative labels in the recesses in the top of the case for the unit, check that the surfaces are clean and free from any protrusion. Should there be a small pip left behind by the injection moulding process, this may be removed by the careful use of a sharp blade. To apply the two plastic/aluminium labels, simply remove their backing papers and locate at one end of their recesses before pressing down.

The battery and tune information labels are applied to the inside surfaces of the access panels, having removed their backing papers. Take care to position these centrally and squarely on the panels as they are impossible to remove successfully once stuck down. The complete unit should now be ready for testing.

Step 16 – Testing

- (A) Clip two fresh PP3 type batteries into the completed unit, in the positions shown. As the second battery makes contact, absolutely nothing should happen if everything is O.K. Should the unit emit a loud click at this point, something is wrong. Either you have put both batteries in the wrong way round or there is a serious fault on the printed circuit board, more than likely a transistor is the wrong way round. Thus it will be necessary to back-track to discover what the fault is.
- (B) Turn each of the three controls 'V', 'S' and 'T' to their fully clockwise positions. Set the selector switches to the positions B/1. Now short out terminals 3 and 4 using the blade of a screwdriver or some other metallic object. The unit should respond by playing tune A3, Beethoven's "Fate Knocking" Theme (or Victory V).

Fig. 18

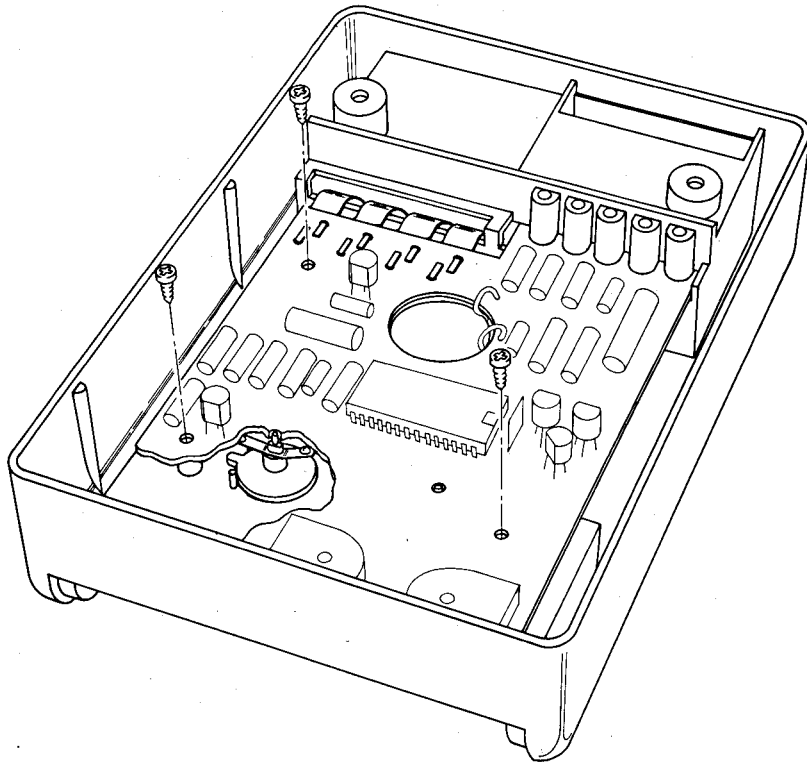
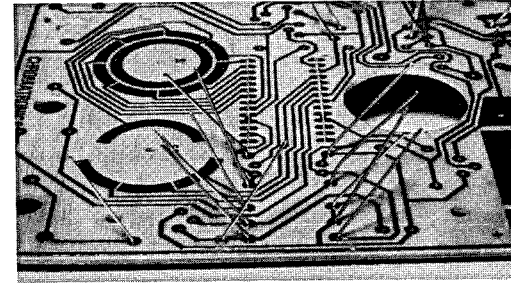

Fig. 1



or cotton cloth before making a small group of soldered joints in order to remove the dross and old flux which might otherwise spoil the next joint. When making a joint, bring the tip in contact with both the lead and the printed circuit pad to heat simultaneously with the solder as shown in Fig. 3. Just apply enough solder to surround the pad and lead and leave a smooth bright joint, as in Fig. 3.

If too little heat is applied to a joint, the solder will form a poor uneven shape and may also be 'dry'. A 'dry' joint will not make a satisfactory connection and may even be intermittent, giving very poor reliability. If the component lead is moved whilst the solder joint to it is still cooling, the joint must be re-heated or else a 'dry' joint may form.

If too much heat is applied to the joint, the solder will crystalize and the joint will look dull and grainy and the track or pad of the printed circuit board may peel off. This damage may be repaired by cutting off the peeled track or pad. The lead of the component at the damaged site should be bent over hard at right angles on the surface. The lead and undamaged (clean) track can then be linked by soldering in a small piece of bare wire across the gap.

Modern silicon transistors and diodes are quite robust as regards damage by heat. It is very difficult to harm them normally, even so when making a joint with one of these devices or any other component, the soldering iron should not be in contact with the lead for any longer than 5 seconds.

Fig.2

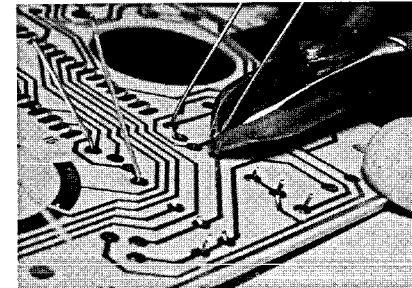
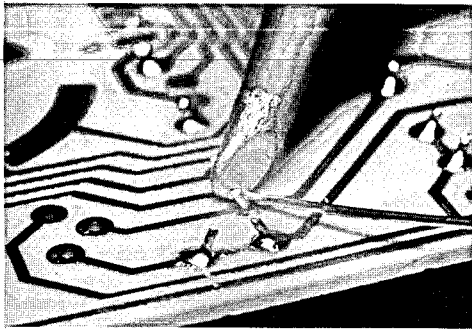

Fig. 3



PRINTED CIRCUIT BOARD ASSEMBLY

Step 1 – Resistors

Sort out all the resistors from Pack 1 and check the colour codes against the resistor parts list. All the resistors are then inserted into the printed circuit board in their respective 'R' locations, as indicated by the printed legend. Make sure each resistor lies flat on the board before the leads are bent over, in order to retain them. There is no special way round for resistors, but it is easier to check the colour codes if the tolerances bands (usually gold) are all pointing the same way round.

Step 2 – Capacitors

The three capacitors used on the "Chroma-Chime" should be very easy to sort out, although these components are notorious for having confusing numbers and codes printed all over them besides the important capacitance values. The two larger devices are both electrolytic capacitors, which are very sensitive to polarity. These must be inserted the correct way round in the printed circuit board as shown. Figure 4 shows a PCB with axial type capacitors used, Fig. 5 shows a PCB with radial leaded capacitors used; either type may have been supplied with your kit. The printed side of the PCB clearly shows the positions of C1 and C2, with the polarity marked with a + sign. Some types of electrolytic are clearly marked to show the + and - leads, sometimes just the - (negative) leads and sometimes no actual + or - sign at all on some kinds of axial types. When the capacitor lead comes out at either end (i.e. an axial type), the lead attached to the can of the capacitor is negative and the lead going through the dark coloured seal is the positive.

The small plate ceramic capacitor, C3 (47pF), should be treated with some care as it is fairly delicate. The leads to this device should be pre-bent with a pair of long nosed pliers, prior to insertion in the PCB, so that no undue strain is applied in the operation.

The two selector contacts are asymmetrical so that when correctly positioned on the shaft of the knob, they will both have their longer arm overhanging the tab moulded on the flange of the knob, as shown in Fig. 16. Be sure that you have assembled these selector switches properly or else your "Chroma-Chime" will not work.

Fig. 16

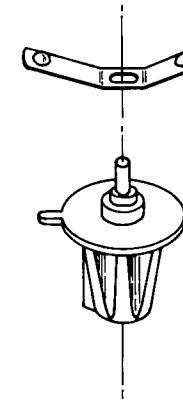

Step 14 – Final Assembly

Assembling the printed circuit board into the case is not as difficult as it might first seem, the trick is to get the board at the right angle. Hook the four battery contacts into the slot provided, keeping the board at about 30° to the case. Almost simultaneously locate the terminal panel into its slot. The board should now simply drop into position trapping the ends of the shafts of the selector knobs through the holes S1 and S2. (Fig. 17)

Fig. 17

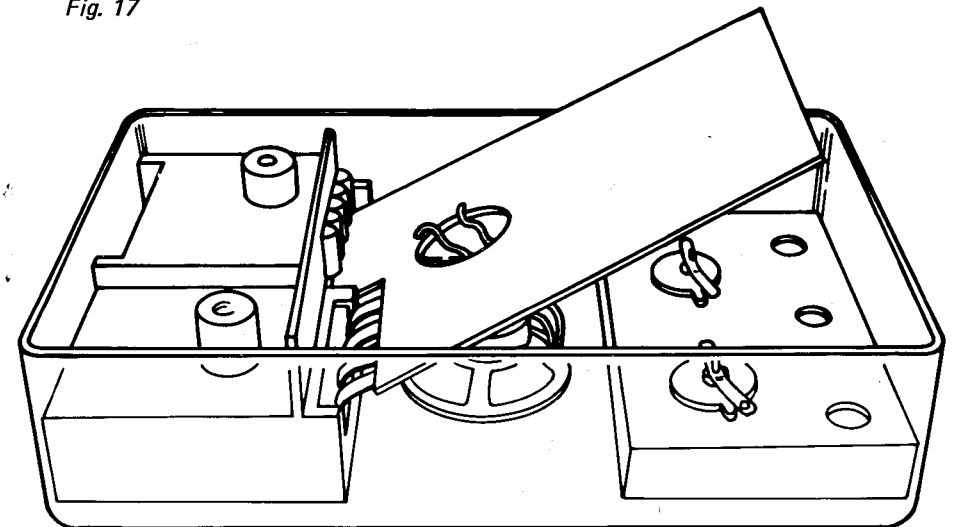

Fig. 15

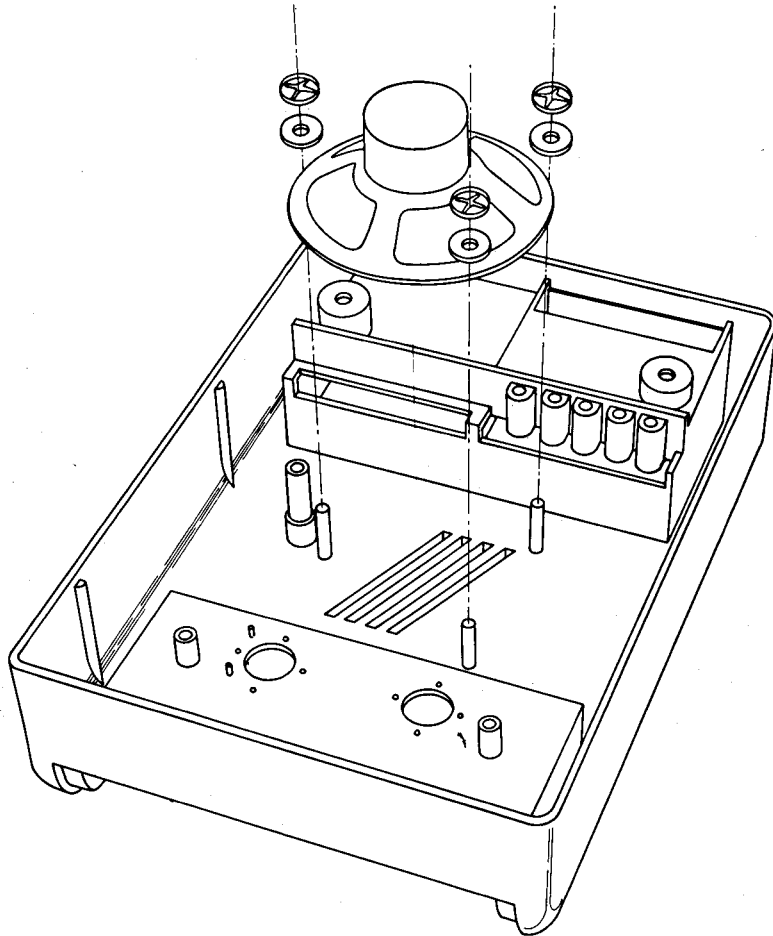

Fig. 4

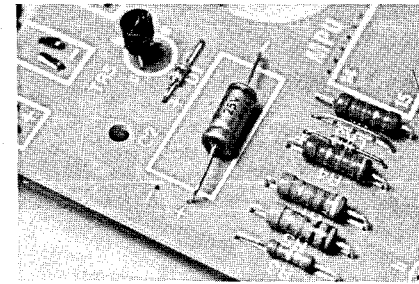
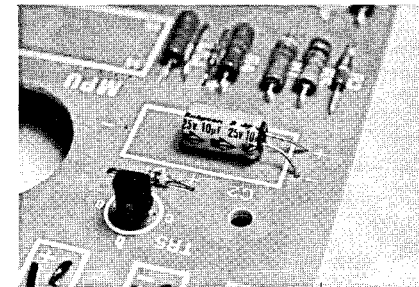

Fig. 5



Step 3 – Diodes and Transistors

The four diodes on the PCB are mounted in the same manner as the resistors, except that you must observe their polarity. The cathode of each diode is the end indicated with a broad band right on the end of the body (note Fig. 6). The lead at this end is assembled into the hole with a + sign. The leads of the diodes should be carefully bent with long nosed pliers prior to assembly, in order to avoid bending the leads too close to the glass body, which might otherwise easily break. Double check that all the diodes are in the right way round before proceeding any further.

Fig. 6

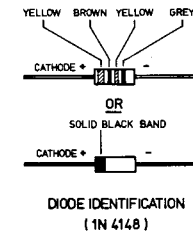

The lead configurations for the three different type of transistors supplied are shown in Fig. 7. The PCB is printed with the lead designations 'E' (Emitter), 'B' (Base), 'C' (Collector) for each of the five transistor locations. You will also note that each location has been printed with the letter 'P' or 'N' to indicate whether the transistor is NPN or PNP. Check the type number on each transistor against the parts list and refer to the lead

Fig. 7

| PART NO. | TYPE | MANUFACTURER | PIN CONFIGURATION |
|------------------|-----------------|--------------|-------------------|
| TR.1, TR.2, TR.5 | ZTX108 | FER. | 7 |
| | BC 108 | ITT, NS, TI | 5 |
| | BC182 / BC183 | TI | 1 |
| | BC182 / BC183 | NS | 4 |
| | BC182L / BC183L | TI | 3 |
| | BC172 | ITT | 3 |
| | BC172 | NS | 4 |
| TR.3 | BC 212 | TI | 1 |
| | BC 212 | NS | 4 |
| | BC 212L | TI | 3 |
| | ZTX 212 | FER | 7 |
| | BC 205 | FCH | 6 |
| | BC 205 | NS | 4 |
| TR.4 | BFR 61 | TI | 2 |
| | BC 327 | ITT | 3 |
| | ZTX 550 | FER | 7 |

FCH - FAIRCHILD SEMICONDUCTOR
 ITT - ITT SEMICONDUCTOR
 TI - TEXAS INSTRUMENTS

FER - FERRANTI
 NS - NATIONAL SEMICONDUCTOR

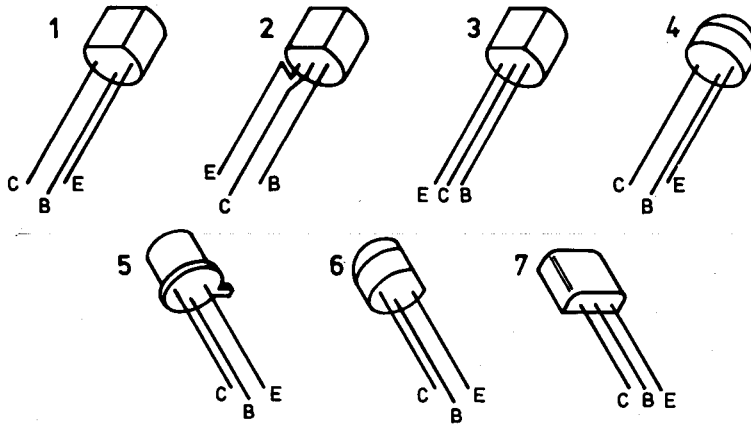

TRANSISTOR IDENTIFICATION

Fig. 8

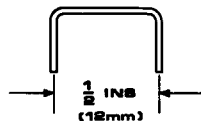

arrangement location. Then insert the transistor's leads in the holes provided, having bent the legs outwards to correspond with the holes marked EBC. Double check once again before proceeding any further.

Fig. 14

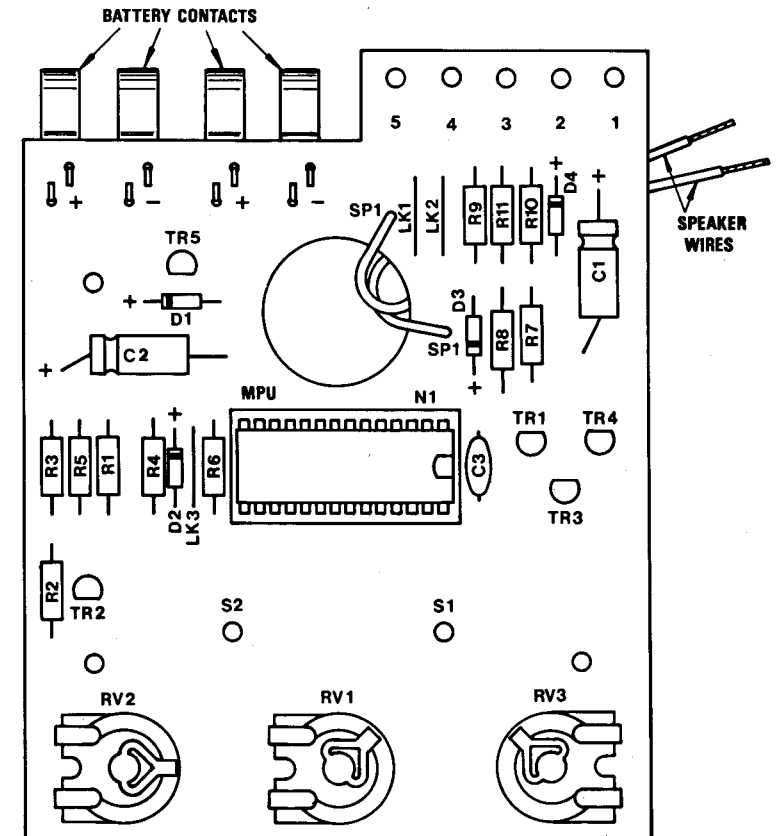

better if someone else could do this for you and make absolutely sure that nothing has been missed or done incorrectly and that all the soldered joints have been done properly. The importance of close inspection cannot be over-emphasized as it might save you trouble later on, trying to find out why your unit will not work properly!

Fig. 13

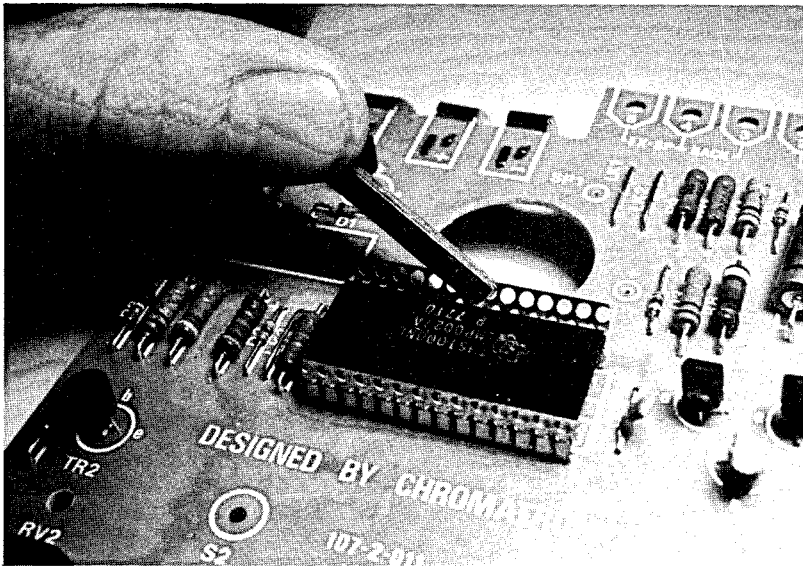

Step 12 – Loudspeaker

The loudspeaker is fitted into the main case such that it sits inside the three retaining posts. Before fitting the special Starlok washers, three anti-vibration rubber washer go over the three posts, as shown in Fig. 15. In order to fit the Starlok washers, you will either need a small tubular spanner or, alternatively, the plastic case of an old ball point pen (anything with an inside diameter just slightly larger than the diameter of the posts will do). The Starloks are pushed very firmly downwards over the posts pinching the rubber washers on to the rim of the loudspeaker. Be careful not to apply any sideways force to the post, otherwise it might break off. Now solder the two loudspeaker wires from the printed circuit board on to the two tags on the speaker.

Step 13 – Fitting the Selector Switches

The two selector knobs are simply dropped into their apertures in the case from the bottom side. The knob on the left hand side is only intended to operate in three positions but it is necessary for the stop moulded on the knob, to be positioned between the two small pegs which prevent it from over-travel.

Step 4 – First Soldering Stage

At this point in the construction, the majority of the components have been assembled on the board and all the leads cropped to the required length. Now proceed to solder in each of the components, taking care to make a neat joint on each of the pads. Take care not to use too much solder where a lead comes out adjacent to a printed circuit pad not yet occupied, otherwise the adjacent hole may get filled in with surplus solder.

Step 5 – Wire Links

From the croppings of the resistor leads, select four long bright pieces of bare wire. Form each of these in a 'U' shape (see Fig. 8), with long nosed pliers, so that the ends are approximately $\frac{1}{2}$ " (12mm) apart. These may then be assembled on to the PCB in the positions marked LK1, LK2, LK3 and LK4. Bend their leads over, on the opposite side of the board, as before, in order to stop them all falling out.

Step 6 – IC Socket

The IC Socket is mounted on the PCB in the MPU – N1 position as shown in Fig. 9. Note that the connecting strip is left in situ oriented outside the IC pin area. It may be necessary to hold this upright whilst soldering each of the end pins in order to stop the strips falling out.

Do not attempt to break off the connecting strips until all 28 pins have been securely soldered in position. This operation is carried out after step 10, once the IC has been properly inserted.

Step 7 – Control Pots

Since RV3 10K ohms is a different value from the other two, RV1 and RV2, it is best that this is assembled on the PCB first. Having done this, insert the other two marked 100K. Bend over the tabs to the three pots at roughly 45° in order to stop them falling out.

Fig. 9

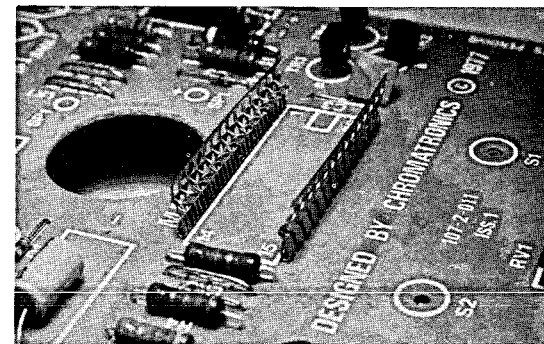

Step 8

The four battery contacts are assembled on the track side of the printed circuit board as shown in Fig. 10. Each contact must be held tightly in position, as the securing tabs are bent over using pliers. Once this has been done, all four contacts may be sweated to the track, using liberal amounts of solder applied to the rectangular holes as shown in Fig. 11. The three pots and the IC socket may also be soldered in at this point.

Fig. 10

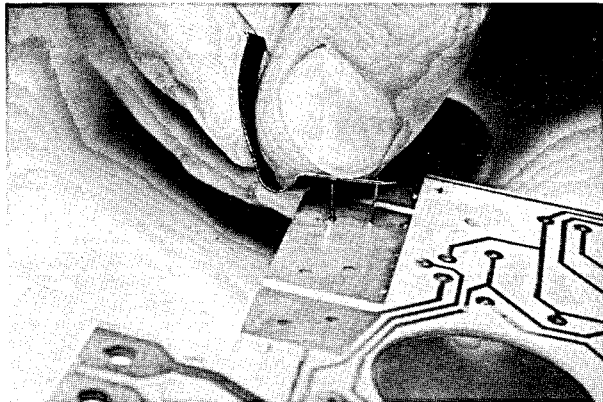

Step 9 – Loudspeaker Connections

The two pieces of insulated wire should be stripped $\frac{1}{4}$ " from each end. Very lightly tin each of the ends in order to stop the strands splaying out. If you should use too much solder on the end which has to go into the printed circuit board you may have to cut it off and re-strip and tin again. Solder in each of the wires in the positions marked SP1 having pushed the ends through from the component side of the printed circuit board. Having tidied up the joints, loop the two wires through the large loudspeaker aperture, so that they emerge on the track side of the printed circuit board, ready for final assembly.

Step 10 – Integrated Circuit

The LSI micro-computer circuit may now be removed from its protective packing. Remember: care must be taken not to handle it unnecessarily. Check that the 'legs' are true and straight. If not, they may be carefully bent with long nosed pliers. The two rows of parallel pins are usually splayed out very slightly wider than the mounting holes in the IC socket. If this is so, it will be necessary to gently push the IC down edgewise on the flat of the pins, on a hard surface (e.g. wood or formica work top). The exact distance between the tips of adjacent rows of pins should be 0.6 " (15mm).

Fig. 11

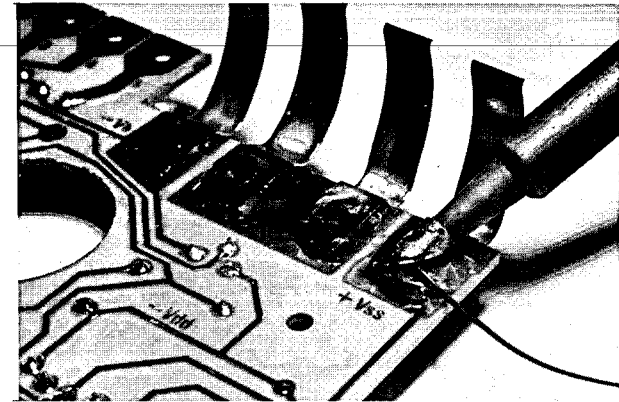

The IC may now be located in its socket on the PCB. Care must be taken to ensure that this is done the right way round, with the rectangular alignment mark facing C3 as shown in Fig. 12. Before pressing the device home, check that all 28 pins will go into the centre of each hole in the IC socket. Having done this, you will probably have to use a fair amount of even pressure to push the micro-computer right down firmly into its socket. Check that all the pins have gone down properly, and not been accidentally scrunched under the device. Break off the IC socket pin connecting parts by bending them downwards repeatedly with long nosed pliers, as shown in Fig. 13.

Fig. 12

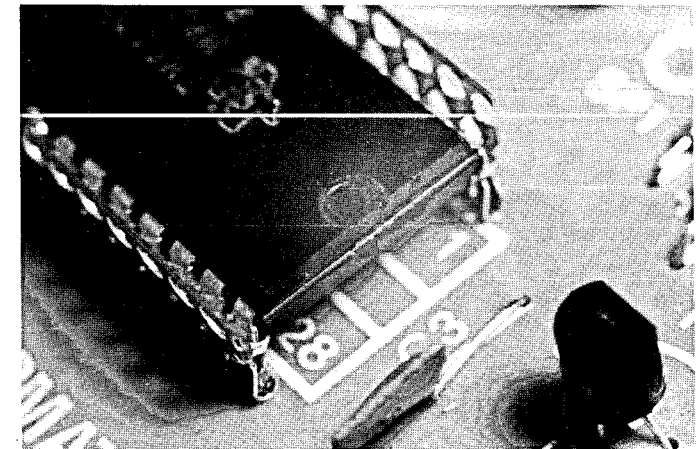

Step 11 – Inspecting the Board

Now you have completed the PCB assembly and are ready to move to the final assembly and test, you must very carefully check your work against the PCB assembly drawing in Fig. 14 and the parts list. It would be even